

May 2015



DMfit®



DMfit®

PUSH-IN TUBE FITTINGS



WRAS approval :

DMfit® complies with WRAS requirements of the United Kingdom Water Regulations.



US FDA approved materials :

DMfit® fittings are produced using FDA approved materials.



SK Zert, ANSI/NSF-51, 61 Certifications :

DMfit® fittings are suitable for contact with foodstuffs & drinking water.



ISO 9001/ISO14001 Certifications :

DMfit® fittings are produced under a registered ISO 9001 / ISO 14001 quality system.

ISO 9001 ISO 14001

Since our creation in 1987, we have taken a leading position in the plastic extruded casing industry because of our quality-first mindset, integrity and technical leadership.

Now, we have made a second bold leap - into the fittings business. The goal is to be a global leader, providing the best net value in fittings products to the entire range of fluid handling industries.





CONTENTS

TECHNICAL INFORMATION

Terms and Conditions	5
General Specifications	6

INCH SIZE PRODUCTS

Acetal Fittings (Gray)	8
Acetal Fittings (White)	14

METRIC SIZE PRODUCTS

Acetal Fittings (Black)	19
-------------------------------	----

POWER PRODUCTS

Acetal Power Fittings(Inch/Metric)	26
Clean Fittings	28

P-P PRODUCTS

Polypropylene Fittings	29
------------------------------	----

VALVE PRODUCTS

Stop & Faucet Adaptor Valves	34
Control Valves	36
Hand Valves	38
Check Valves	41
Stop Valves	42

OTHERS

Filter Strainers	43
Brass Fitting(Inch/Metric)	44
Cartridges	45
Full Cartridges	47
Accessories	48
LLDPE TUBES	50
Chemical Compatability	51

PUSH-IN TUBE FITTINGS

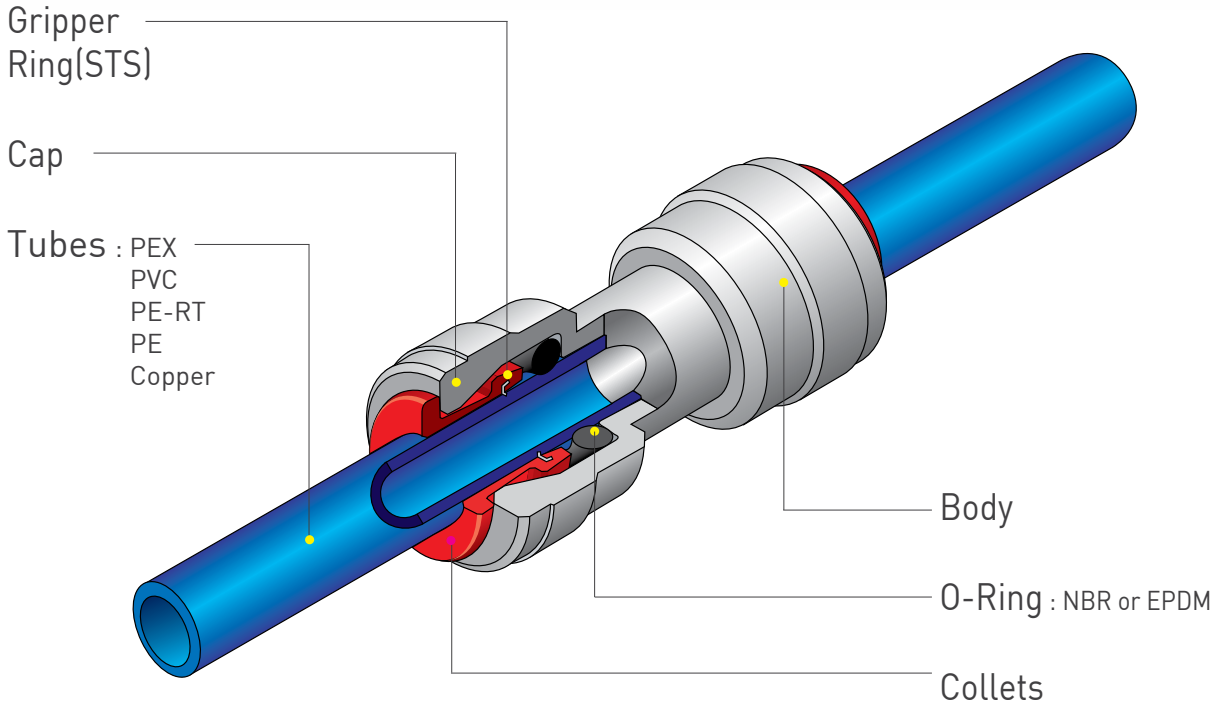

Material Standards

Material Options	Fittings Color	O-ring
A - acetal	Gray, Black, White	NBR / EPDM
P - polypropylene	White	
B - brass	brass, or chromed	

Fitting Working Pressure and Temperature

Temperature	Small Size						Large Size				28mm	
	5/32"	3/16"	1/4"	5/16"	3/8"	1/2"	5/8"	7/8"	1 1/8"	1 1/2"		
	4mm	5mm	6mm	8mm	10mm	12mm	15mm	16mm	18mm	22mm		
1°C (34°F)	16bar (230PSI)						11bar (170PSI)		11bar (170PSI)			
20°C (68°F)	16bar (230PSI)						11bar (170PSI)		11bar (170PSI)			
65°C (150°F)	10bar (150PSI)						7bar (100PSI)		7bar (100PSI)			

Outer Diameter Tolerance Limit of Tubing Used with Fittings

	Size	Tolerance
Small Size	5/32", 4mm	±0.004" (±0.1mm)
	3/16", 5mm	
	1/4", 6mm	
	5/16", 8mm	
	3/8", 10mm	
Large Size	1/2", 12mm	±0.004" (±0.1mm)
	5/8", 15(16)mm	
	7/8", 18(22)mm	
	28mm	

※ For use at higher temperatures or pressures, please contact your DMfit representative for assistance.

Maximum Permissible Torque

Torque		Thread		1/8", 1/4"		3/8", 1/2"		3/4"	
		Material	Maximum Torque (Nm)	1/8", 1/4"	3/8", 1/2"	3/4"			
Plastic	Maximum Torque (Nm)		1.5	3.0		4.0			
	Steel	Maximum Torque (Nm)	7.0-9.0	12.0-14.0	22.0-24.0	28.0-30.0	40.0		

※ The above values are average maximum applied torque. Actual results may vary.

Installing DMfit Fittings

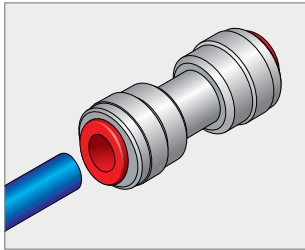

- Cut the part of the tube to be inserted into the fitting to plane the end.
- Make sure to use a clean tube without any foreign material or cracks.

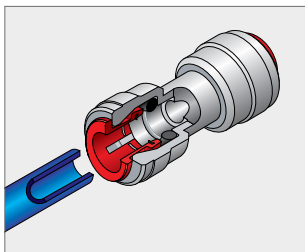

- When inserting the tube, remove any obstructions before fully inserting the tube. Make sure the tube is fully inserted.
- Inserting the tube into the fitting only takes moderate force. The tube or fitting should not be scratched or damaged in the process, as this is the main cause for water leaks later on.

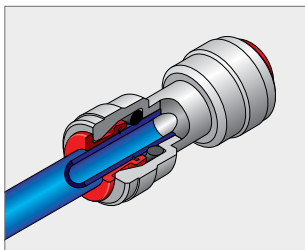

- To make sure that the fitting is properly connected to the tube, pull it once. After pulling, insert a spanner under the collet and push the tube into the fitting once more for a complete insertion.

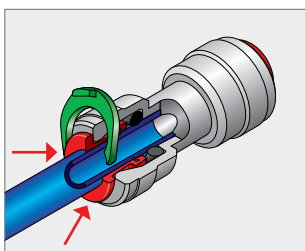

- When no play is desired for the fitting and tube, use our company's LC to eliminate the play of the fitting.

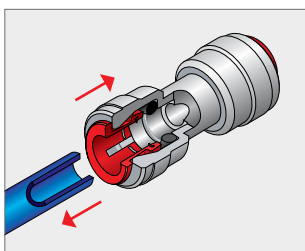

- Make sure to completely eliminate pressure before disassembling the fitting.
- When disassembling the tube, push the clip in direction of the main assembly and then pull the tube out for easy disassembling.
- Fittings and tubes can be reused.

Terms and Conditions

Please read, understand, and follow all instructions, precautions, and warnings prior to using Dmfit® products on pressurized systems. Failure to follow all instructions, precautions, and warnings may result in bodily harm or property damage.

Warnings and Precautions

- ① Fittings are not recommended for use with liquids other than water and food or beverage products. Where fittings may be used with other chemicals contact DMT for advice.
- ② Do not disassemble or modify the individual product, as this may cause a product malfunction, leak, or failure and voids the product warranty.
- ③ Do not over-stress the fitting by rotation, twist, bending, shock, fatigue, or other excess force. This may damage the fitting and cause malfunction, leak, or failure and voids the product warranty.
- ④ Do not use the product where ambient temperature or fluid temperature may exceed 65°C (150°F) in domestic environment Food & Drink, Industrial Pneumatic. This may damage the fitting and cause malfunction, leak, or failure.
- ⑤ Do not use pipe dope or other liquid thread sealers. Use only Teflon tape to seal threaded connections.
- ⑥ If your plumbed line is used as an electrical ground, you must use a jumper wire to provide continuity across plastic fittings and tubing.
- ⑦ Never press collets toward the body unless attempting to separate tubing from a fitting in an unpressurized line. The use of the DMfit® Locking Clip is advised to restrict inadvertent disassembly of connections.
- ⑧ DMT reserves the right to modify the product from time-to-time as required for quality improvement and per market requirements. Actual product may differ from pictures shown.
- ⑨ Connecting DMfit® products to tubing or connecting elements other than DMfit® products is not warranted for performance. Always perform any checks and testing necessary to verify acceptable function.
- ⑩ Before making any tube connection, verify that the end of the tube has been cut squarely and there are no scratches on the tube O.D within 30mm of the end.
- ⑪ When making a tube connection, occasionally a gripping of the tube may occur just as the tube begins to pass through the o-ring, although the seal is not yet made. In this case, push the tube deeply once more to complete assembly of the connection. Failure to completely seat the tube into the fitting may cause a leak.
- ⑫ When using metallic tubing, de-burr the tube ends to avoid potential cutting or other damage to the o-ring.
- ⑬ After assembling a tube connection, tug with moderate force to check for proper gripping of the tube.
- ⑭ Before disassembling tube connections, always verify that pressure has been removed from the system.
- ⑮ When disassembling tube connections, always press the collet evenly toward the body and then pull the tube. If a locking clip is used, remove the locking clip before attempting to separate a tube connection.
- ⑯ When tightening threaded fittings, use care not to over-torque the fitting as this may damage the fitting and cause a leak or other failure.
- ⑰ TS (Tube Support) supports to soft tube and tube at 65°C (150°F) of ambient and fluid temperature.
- ⑱ Our threaded fittings should be complied with our specification. (ref. page 4)

Material Characteristics

- **Acetal** : Also known as POM. Highly durable and resistant to fatigue and creep. It has high resistance to a wide range of organic & inorganic chemicals and detergents. Not recommended for use with strong acids or repeated exposure to strong oxidizers.
- **Polypropylene** : Has excellent chemical resistance, cold endurance, and high tolerance to oxidizers.

PUSH-IN TUBE FITTINGS

Poor DSI assembly

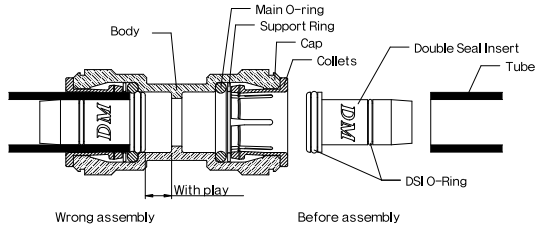

Good DSI assembly

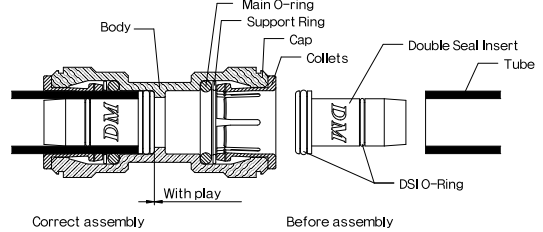

Three way valve to control direction of water flow.

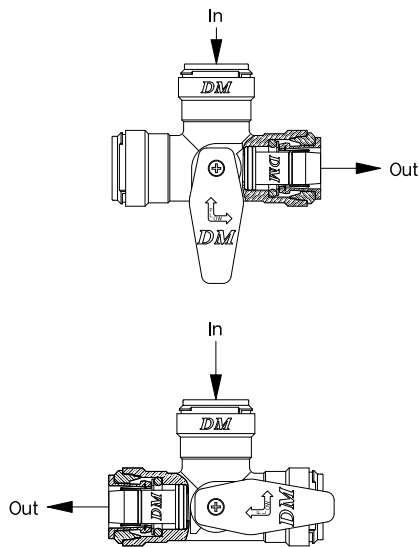

Example of tank connector assembly

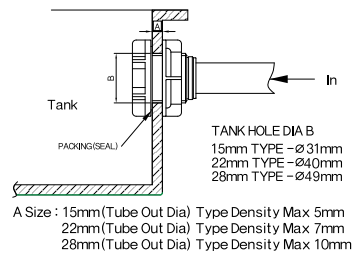

Checking force of a double check valve

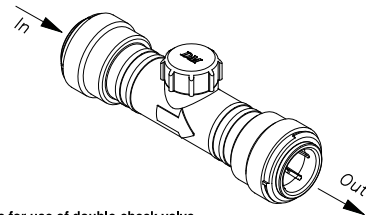

- ※ Notice for use of double-check valve
- In case of reverse pressure, the valve will withstand temporary pressure spikes of up to 10bar.

Hand valve connector

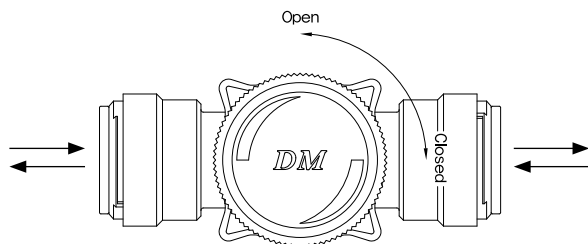

Hose cutter

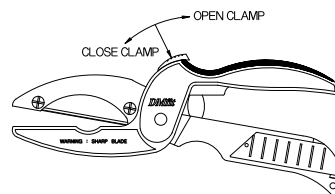

- ※ Notice for using the hose cutter
1. Be careful when using the cutter, as the blade is very sharp.
 2. When the cutter is not in use, put it in "lock" position.

Example of Hand Wash Machine assembly

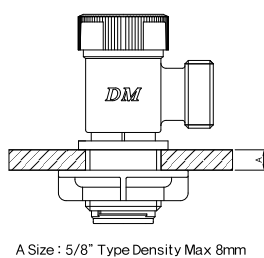

Example of Hand Valve Female Adapter assembly

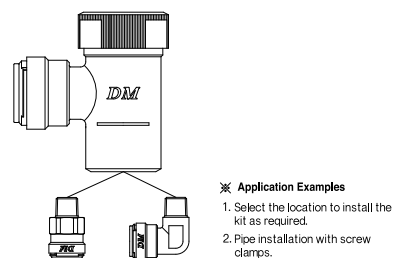

Usage and Features I

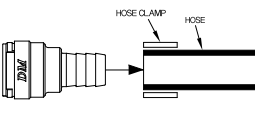

※ **Application Examples**

1. Use connected with a hose.
2. Fix the hose clamp to make sure the connector does not disengage from the hose.
3. When connecting braided hoses, use a pressed metal connector on the connecting end.

Usage and Features II

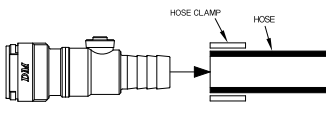

※ **Application Examples**

1. Use connected with a hose.
2. Fix the hose clamp to make sure the connector does not disengage from the hose.
3. When connecting braided hoses, use a pressed metal connector on the connecting end.
4. Water flow can be blocked with the stop valve.

THC-Throttle Hand Valve Connector

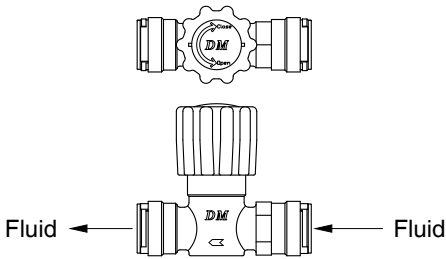

FWC-Four Way Connector

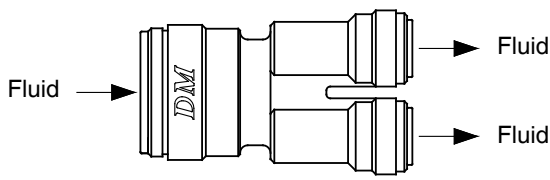

HSV-Hand Stop Valve

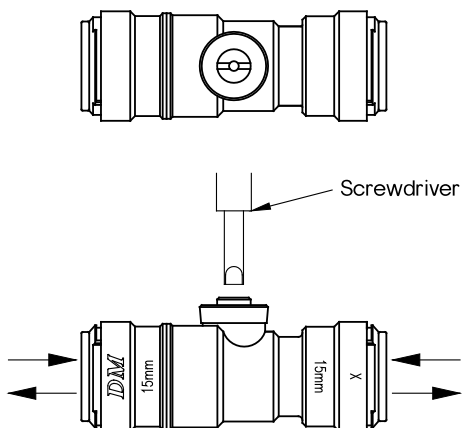

DMfit Fitting Standard Anatomy

● All diagrams are based on the UC0808 product.

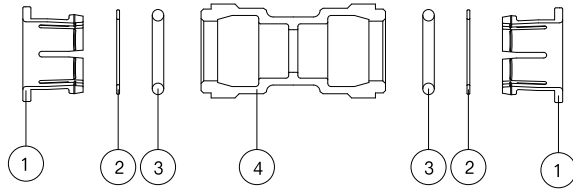

No.	Part Name	Material	Q'ty	Remark
1	Collets	Acetal	2	
2	Support Ring	Acetal	2	
3	O-ring	NBR	2	
4	Body	Acetal	1	

■ Exceptional, Small sizes don't have Sup-Ring in the body.

Flow Bend Clamp Assembly and Application Features

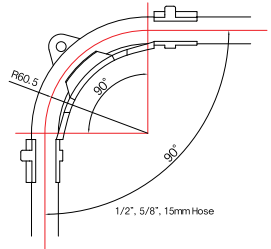

How to Connect the Locking Tube Locking

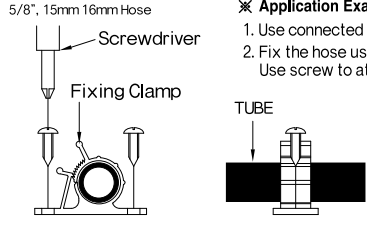

5/8", 15mm 16mm Hose

※ **Application Examples**

1. Use connected with a hose.
2. Fix the hose using the fixing clamp. Use screw to attach the product to a wall.

CARTRIDGES



■ Half cartridges

- Half-cartridges are available in Acetal, Brass and Stainless Steel.
- They provide to simplify your application's size and shapes.
- In addition, they give you more cost effectiveness comparing to Fittings.
- Easy installation, Shorten time to assemble.
- Two O-rings make more completed sealing(Refer to Cavity Dimension).

AC - Acetal Cartridge

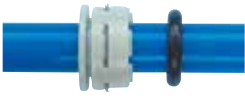

Inch size	PART NO.	Tube O.D.	Qty / Box
ACETAL CARTRIDGE O-RING NBR	ACU 01	5/32	2000
	ACU 03	3/16	2000
	ACP 04	1/4	1000
	ACP 05	5/16	1000
	ACP 06	3/8	700
	ACP 07	1/2	500

Metric size	PART NO.	Tube O.D. (mm)	Qty / Box
ACETAL CARTRIDGE O-RING NBR	ACU 04M	4	2000
	ACU 05M	5	2000
	ACP 06M	6	1000
	ACP 08M	8	1000
	ACP 10M	10	700
	ACP 12M	12	500

BC - Brass Cartridge



Inch size	PART NO.	Tube O.D.	Qty / Box
BRASS CARTRIDGE O-RING NBR	BC 01	5/32	2000
	BC 03	3/16	2000
	BC 04	1/4	1000
	BC 05	5/16	1000
	BC 06	3/8	700
	BC 07	1/2	500

Metric size	PART NO.	Tube O.D. (mm)	Qty / Box
BRASS CARTRIDGE O-RING NBR	BC 04M	4	2000
	BC 05M	5	1000
	BC 06M	6	1000
	BC 08M	8	1000
	BC 10M	10	700
	BC 12M	12	500
	BC 15M	15	500
	BC 22M	22	300

SC - Stainless Steel Cartridge



Inch size	PART NO.	Tube O.D.	Qty / Box
STAINLESS STEEL CARTRIDGE O-RING NBR	SC 01	5/32	2000
	SC 03	3/16	2000
	SC 04	1/4	1000
	SC 05	5/16	1000
	SC 06	3/8	700
	SC 07	1/2	500

Metric size	PART NO.	Tube O.D. (mm)	Qty / Box
STAINLESS STEEL CARTRIDGE O-RING NBR	SC 04M	4	2000
	SC 05M	5	1000
	SC 06M	6	1000
	SC 08M	8	1000
	SC 10M	10	700
	SC 12M	12	500
	SC 15M	15	500
	SC 22M	22	300

CARTRIDGES

Cavity Dimension

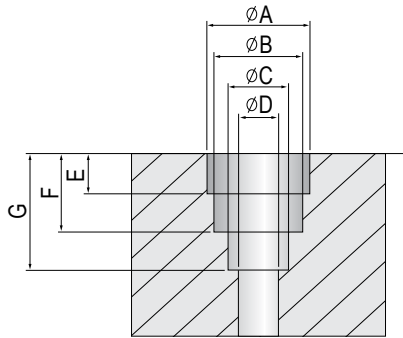

Assembly

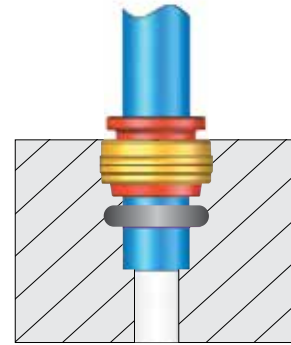

Inch Sizes

(Unit: inch)

Size (Inch)	$\phi A \pm 0.002''$	$\phi B \pm 0.002''$	$\phi C \pm 0.002''$	$\phi D \pm 0.002''$	$\phi E \pm 0.01''/-0$	$\phi F1 \pm 0.006''$	$\phi F2 \pm 0.006''$	$\phi G1 \pm 0.006''$	$\phi G2 \pm 0.006''$
5/32	0.490	0.317	0.161	0.098	0.181	0.370	0.462	0.502	0.594
3/16	0.470	0.344	0.197	0.126	0.181	0.370	0.462	0.502	0.594
1/4	0.528	0.421	0.257	0.169	0.181	0.373	0.477	0.545	0.653
5/16	0.542	0.465	0.323	0.217	0.213	0.413	0.508	0.615	0.709
3/8	0.630	0.563	0.382	0.250	0.268	0.472	0.574	0.719	0.822
1/2	0.775	0.661	0.508	0.374	0.303	0.525	0.629	0.827	0.945

Metric Sizes

(Unit: mm)

Size (mm)	$\phi A \pm 0.05$	$\phi B \pm 0.05$	$\phi C \pm 0.05$	$\phi D \pm 0.05$	$\phi E \pm 0.25/-0$	$\phi F1 \pm 0.15$	$\phi F2 \pm 0.15$	$\phi G1 \pm 0.15$	$\phi G2 \pm 0.15$
4	12.44	8.05	4.20	2.50	4.59	9.39	11.73	12.75	15.08
5	11.93	8.73	5.20	3.50	4.59	9.39	11.73	12.75	15.08
6	13.41	10.69	6.20	4.00	4.59	9.47	12.22	13.84	16.59
8	13.76	11.81	8.20	6.00	5.41	10.50	12.90	15.63	18.00
10	16.00	14.30	10.20	7.00	6.80	11.98	14.28	18.27	20.87
12	19.68	16.78	12.20	9.00	7.69	13.33	16.27	21.00	24.00
15	22.90	20.20	15.20	12.00	9.00	17.20	20.00	26.30	26.30
22	31.05	27.60	22.20	19.20	10.90	21.10	24.30	31.30	31.30

※ Double O-rings half cartridges : Columns F2 and G2

Structure

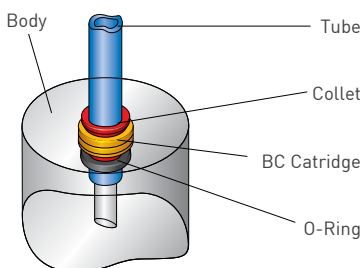

How to assemble

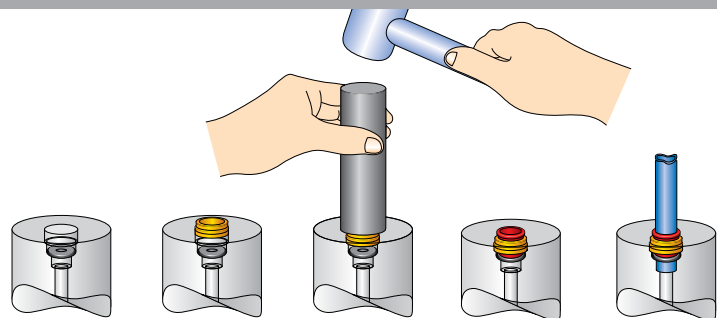

- Caution
- Tap softly with special tool standing for inserting cartridge into the Cavity. (Use the tool with flat base if you don't have any special tool for an insert cartridges)
- Please check up the breakaway a cartridge from the Cavity with pulling gently the tube inserted.

FULL CARTRIDGES

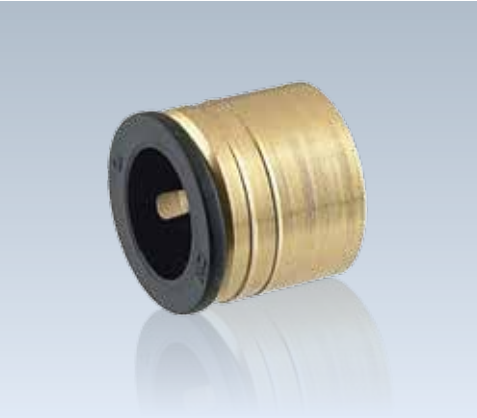

■ Features

DM full cartridges are designed to provide a saving cost and effective way to connect tubes perfectly into metallic products.

The cartridge is supplied with NBR O-ring and collet.

The cartridge are good for compressed air applications.

Please do check if your application is required an additional bonding on.

Please do refer to our plastic cartridges shown on pages 45 to 46 of this catalogue if you need to install connections into plastic products.

■ Cavity Dimensions

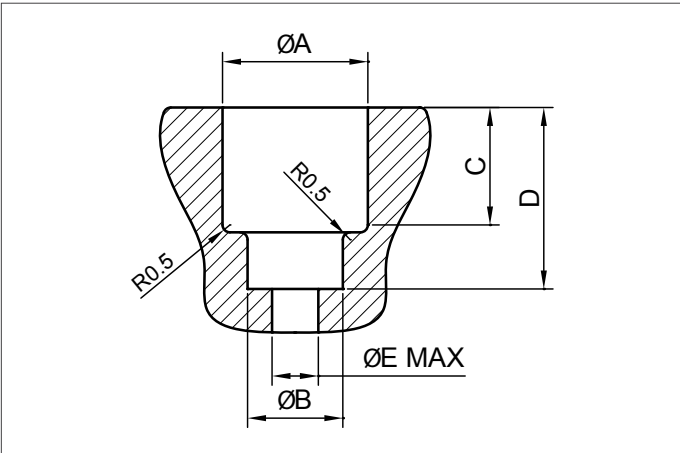
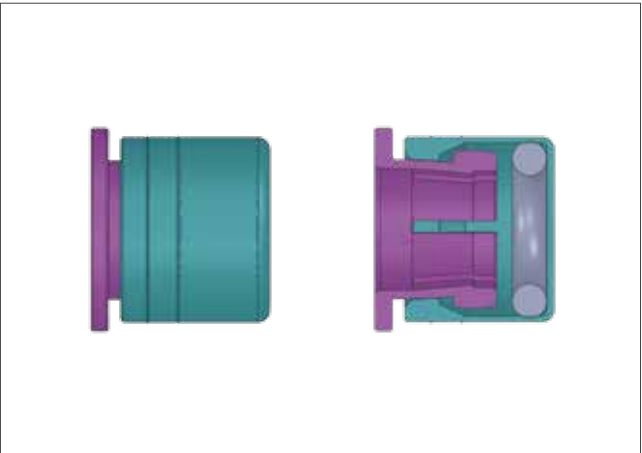

Metric Sizes



Size(mm)	$\phi A \pm 0.05$	$\phi B \pm 0.05$	$\phi C \pm 0.25$	$D \pm 0.15$	$\phi E \text{ MAX}$
4	9.12	4.20	9.30	12.65	2.75
5	9.82	5.20	9.90	13.25	3.50
6	11.78	6.20	11.30	15.67	4.00
8	12.88	8.20	11.05	16.18	6.00
10	15.38	10.20	12.40	18.69	7.00
12	17.88	12.20	13.80	21.47	9.00

※ All dimensions in Metric.

ACCESSORIES

TS - Tube Support



PART NO.	Tube O.D.	Tube I.D.	Qty / Box
ATS 04	1/4	0.170	3,500
ATS 05	5/16	0.216	3,000
ATS 06	3/8	1/4	1,500
ATS 07	1/2	0.350	800
ATS 08	5/8	0.476	600
ATS 10	7/8	0.669	500

- The tube support is recommended for use with soft or very thin walled tubing.

PART NO.	Tube O.D. (mm)	Tube I.D. (mm)	Qty / Box
ATS 06M	6	4	3,500
ATS 08M	8	6	3,000
ATS 10M	10	7	1,600
ATS 12M	12	9	800
ATS 15M	15	11.4	600
ATS 16M	16	12	600
ATS 18M	18	14	400
ATS 22M	22	17.6	500
ATS 28M	28	23	300

DSI - Double Seal Insert



PART NO.	Tube O.D.	Tube I.D.	Qty / Box
ADSI 06	3/8	1/4	2,000
ADSI 07	1/2	0.332	1,000
ADSI 08	5/8	0.472	800
ADSI 10	7/8	0.669	600

PART NO.	Tube O.D. (mm)	Tube I.D. (mm)	Qty / Box
ADSI 08M	8	6	3,000
ADSI 10M	10	7	2,000
ADSI 12M	12	9	1,000
ADSI 15M	15	11.5	600
ADSI 16M	16	12	800
ADSI 18M	18	14	600
ADSI 22M	22	17.5	600
ADSI 28M	28	23	400

COV - Collet COVER



PART NO.	Tube O.D.	Qty / Box
ACOV 04	1/4	700
ACOV 05	5/16	600
ACOV 06	3/8	600
ACOV 07	1/2	500
ACOV 08	5/8	500
ACOV 10	7/8	300

PART NO.	Tube O.D. (mm)	Qty / Box
ACOV 06M	6	700
ACOV 08M	8	600
ACOV 10M	10	600
ACOV 12M	12	500
ACOV 15M	15	500
ACOV 16M	16	500
ACOV 18M	18	400
ACOV 22M	22	300
ACOV 28M	28	200

LC - Locking Clip



PART NO.	Tube O.D.	Qty / Box
ALC 03	3/16	12,000
ALC 04	1/4	10,000
ALC 05	5/16	8,000
ALC 06	3/8	7,000
ALC 07	1/2	5,000
ALC 08	5/8	2,500
ALC 10	7/8	2,000

PART NO.	Tube O.D. (mm)	Qty / Box
ALC 05M	5	12,000
ALC 06M	6	10,000
ALC 08M	8	8,000
ALC 10M	10	7,000
ALC 12M	12	5,000
ALC 15M	15	4,000
ALC 16M	16	4,000
ALC 18M	18	3,000
ALC 22M	22	2,000
ALC 28M	28	2,000



FBC - Flow Bend Clip



PART NO.	Tube O.D.	Qty / Box
AFBC 05	5/16	300
AFBC 06	3/8	200
AFBC 07	1/2	150

PART NO.	Tube O.D. (mm)	Qty / Box
AFBC 06M	6	400
AFBC 08M	8	300
AFBC 10M	10	200
AFBC 12M	12	150

PART NO.	Tube O.D.	Qty / Box
NFBC 08	1/2(12mm) to 5/8(15mm)	100

- FBC 08 is made from Nylon 66.
- Provides a simple method for smooth 90 degree tube bend without twist.
- Can be built into the equipment or walls with screws.

SP - Spanner



PART NO.	Tube O.D.
ASP	3/16, 1/4, 5/16, 3/8, 1/2

HTC - Hand Tube Cutter

(Nylon)



PART NO.	Tube O.D. (Minimum)	Tube O.D. (Inch) (Maximum)
NHTC 08	5/32(4mm)	5/8 (16mm)

PSP - Power SPanner

(Nylon)



PART NO.	Tube O.D.
NPSP	5/16, 3/8

- Available in metallic spanner

TC - Tube Cutter



PART NO.	Tube O.D.	Qty / Box
TC	MAX. DIA 1/2" or 13mm	40

- DMfit® Tube Cutter with quality blade is suitable for cutting plastic tubing sizes up to 13mm.

Hook



PART NO.	Size (mm)	Qty / Box
AHOOK	19.5	

TLC - Tube Locking Clamp

(Nylon)



PART NO.	Tube O.D.	Qty / Box
NTLC 08	5/8(16mm)	200

RA - Release Aid



PART NO.	Tube O.D.	Qty / Box
ARA 06	3/8	700
ARA 07	1/2	700
ARA 08	5/8	600
ARA 10	7/8	500

PART NO.	Tube O.D. (mm)	Qty / Box
ARA 10M	10	700
ARA 12M	12	700
ARA 12M	12	600
ARA 15M	15	600
ARA 16M	16	600
ARA 18M	18	500
ARA 22M	22	500
ARA 28M	28	500

EFCAP - Easy Fitting CAP



PART NO.	Tube O.D.	Qty / Box
AEFCAP 04	1/4	1000

- Fittings need to be separated from the Tank and The Filter, Especially under the pressure It can offer a solution : EASY and Quick Separation by Using The Cap.

• FITTING + TUBE

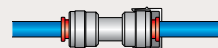

• FITTING + FILTER

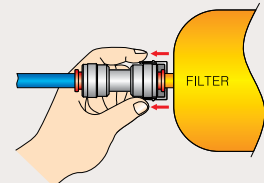

• FITTING + STEM FITTING

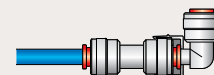

CHEMICAL COMPATIBILITY TABLES

DMfi[®] has excellent resistance to exposure to organic compounds, industrial chemicals, and gases.

■ Resistance of chemical characteristics for plastic resins & elastomers.

Description (% , °C)	Brass	SUS	Resin		Rubber	
			Acetal	PP	NBR	EPDM
Caustic soda(10%, 20°C)	△	△	◎	○	○	◎
Gasoline	○	○	◎	△	◎	×
Formic acid(25%, 20°C)	×	△	×	◎	○	◎
Air	◎	◎	◎	◎	◎	◎
Mineral oil	○	○	◎	○	◎	×
Grease	○	◎	◎	△	◎	×
Sodium silicate	○	-	◎	◎	◎	◎
Glycerin	○	◎	◎	◎	◎	◎
Ozone	○	○	△	△	○	◎
Animal oil(Lard oil)	○	-	◎	○	◎	○
Kerosene	◎	◎	◎	◎	◎	×
Methane	○	-	◎	◎	◎	×
Methyl alcohol(Methanol)	◎	△	○	○	◎	◎
Water(24°C)	○	○	◎	◎	◎	◎
Water(100°C)	×	○	△	△	-	-
Sea water	△	○	◎	◎	-	-
Bunker oil	△	-	-	○	◎	-
Benzene(Benzol)	×	△	○	△	×	×
Butane	◎	◎	◎	◎	◎	×
Fluorine	×	×	×	×	-	△
Boric acid	○	○	○	◎	◎	◎
Carbon tetrachloride	△	△	○	△	△	×
Oxygen	◎	◎	○	○	○	◎
Petroleum	-	-	○	×	◎	×
Soda ash(Sodium carbonate)	○	△	◎	◎	◎	◎
Calcium hydroxide	△	△	◎	○	◎	◎
Hydrogen	△	◎	◎	◎	◎	◎
Mercury	×	-	-	◎	◎	◎
Steam(150°C)	○	-	△	×	×	◎
Sodium cyanide	×	-	-	-	◎	◎
Vegetable oil	-	-	○	○	◎	◎
Silicone greases	-	-	◎	△	◎	◎
Silicone oil	-	-	◎	△	◎	◎
Acetone	◎	△	○	△	×	◎
Sulfurous acid gas	-	-	△	○	○	◎
Ammonia	△	◎	○	○	◎	◎
Liquefied petroleum gas(LPG)	◎	◎	◎	○	◎	×
Ethyl alcohol(Ethanol)	◎	○	◎	○	◎	◎
Lye solution	-	-	◎	○	○	◎
Hydrochloric acid(10%, 20°C)	×	×	○	◎	-	-
Hydrochloric acid(20%, 20°C)	×	×	△	○	-	-
Hydrochloric acid(20%, 80°C)	×	×	×	×	×	△
Hydrochloric acid(38%, 20°C)	×	×	△	○	○	◎
Ammonium chloride	×	△	○	◎	◎	◎
Calcium chloride	○	△	◎	◎	◎	◎
Naphtha	△	○	◎	△	△	×
Olive oil	△	◎	○	◎	◎	○
Sulfur	×	○	◎	◎	×	◎
Sodium phosphate	×	△	○	◎	◎	◎
Ammonium phosphate	△	△	○	◎	◎	◎
Ammonium nitric	×	○	○	◎	◎	◎
Nitrogen	○	◎	◎	◎	◎	◎
Natural gas	◎	◎	◎	○	◎	×
Acetic acid(10%, 20°C)	-	-	-	-	-	-
Acetic acid(50%, 20°C)	-	-	-	-	-	-
Acetic acid(50%, 70°C)	-	-	-	-	-	-
Acetic acid(100%, 20°C)	-	-	-	-	-	-
Ketones	○	○	○	◎	-	○
Cresol	○	△	△	○	△	×
Chromic acid(2%, 70°C)	×	×	×	△	-	-
Chromic acid(10%, 70°C)	×	×	×	×	-	-
Chromic acid(25%, 70°C)	×	×	×	×	-	-
Chromic acid(2%, 50°C)	×	×	△	△	×	○
Soybean oil	△	○	◎	○	◎	△
Toluene	◎	◎	◎	△	×	×
Glucose	◎	◎	◎	◎	◎	◎
Propane	◎	◎	◎	◎	◎	×
Castor oil	○	○	○	◎	◎	○
Sulfuric acid(10%, 20°C)	×	×	○	○	×	○
Sulfuric acid(10%, 70°C)	×	×	×	△	-	-
Sulfuric acid(30%, 20°C)	×	×	△	○	-	-
Sulfuric acid(30%, 70°C)	×	×	×	△	-	-
Sulfuric acid(98%, 20°C)	×	×	×	×	-	-
Aluminium sulfate	×	○	○	◎	◎	◎
Potassium sulfate	○	△	○	◎	◎	◎
Hydrogen sulfide	△	△	○	◎	×	◎

※ ◎ : Very acceptable ○ : Acceptable △ : Slightly Unacceptable × : Unacceptable - : No data

■ Resistance of chemical characteristics for Tube.

Name of chemical	Polyethylene	Remarks	Name of chemicals	Polyethylene	Remarks
Air	◎		Hexane	△	
Alcohol	◎		Hydrogen gas	◎	
Ammonia gas	◎		Lighting gas	△	
Ammonia liquid	○	high temperature△	Mercury	◎	
Beer	◎		Methanol (Methyl Alcohol)	◎	
Benzene	△		Milk	◎	
Bromine liquid	×		Molasses	◎	
Carbon dioxide gas	○		Nickel salts	◎	
Caustic soda	○		Oils, essential	△	
Diesel fuel	△		Propane gas	△	
Ethyl alcohol	○	high temperature△	Spindle Oil	△	
Fluor gas, dry	×		Water, high-purity	◎	
Fuel Oil	△				

※ : Very acceptable, ○: Acceptable, △: Slightly unacceptable, ×: Very unacceptable

※ Differences in data can exist due to extended duration and elevated temperature (Standard data reflects use at ambient temperature.)

※ Consult our representative when using unsuitable liquids.

GLOBAL SALES

