

4 Port Solenoid Valve Cassette Type Manifold

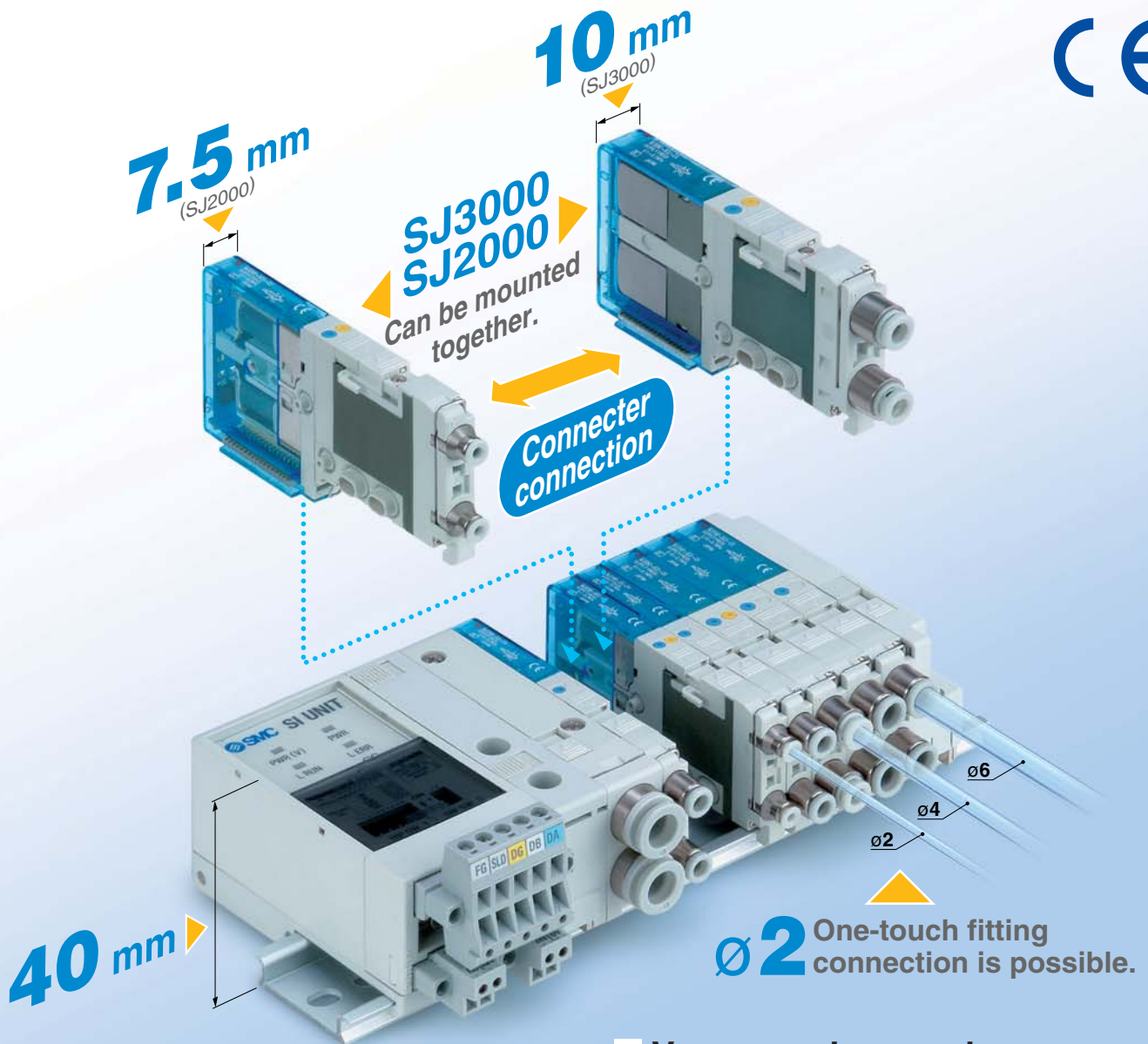

- Non-plug-in type
Individual wiring manifold

New



- Vacuum release valve with restrictor
Suction and release can be controlled with a single unit

New

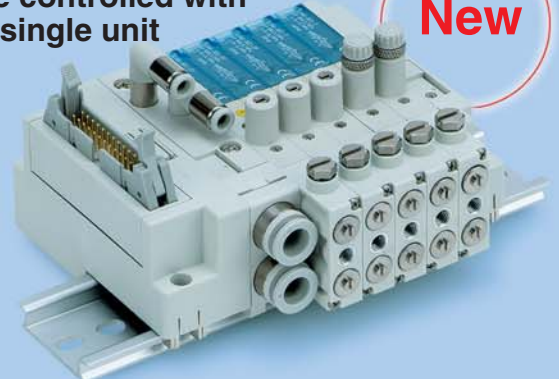

Series **SJ2000/3000**



CAT.EUS11-87B-UK

Power consumption

- 0.15 W (SJ3000 with power saving circuit).
- 0.23 W (SJ2000 with power saving circuit).

Manifold uses halogen-free lead wires

Service life of 50 million cycles or more

(Based on SMC life test conditions)

Connector type (Card edge type)

- Can easily increase or decrease stations and replace valves.
- 34 pins connector allows up to 16 stations with double solenoids, 32 stations with single solenoids.

New

PC wiring compliant

New

Non-plug-in individual wiring compliant



D-sub connector

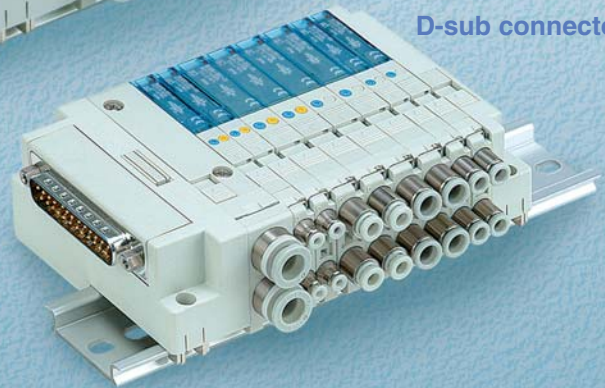

Piping variations

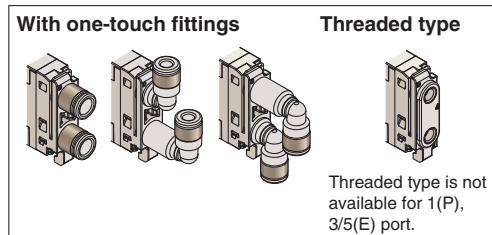

With switch

- Possible to shut the signal of each individual valve.
- Manual operation is possible by switching OFF, even when the valve is in the energised state.

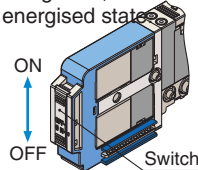

Manual locking

Accidental operation can be prevented by sliding the switch to avoid the manual override button from being pressed.



Fittings are replaceable

Fittings (including type and size) can be easily changed by removing a clip.

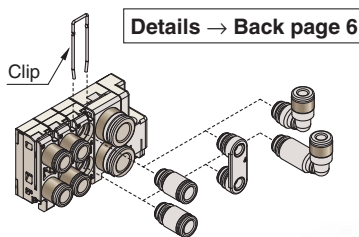

Valve connection mechanism

Connection between valves can be fixed by the valve lock switch. Connection can be confirmed after the connection hook has been inserted into the connection groove of the adjacent valve.

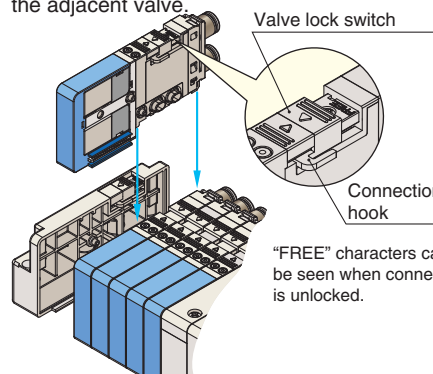

Type of manual override

Non-locking push type

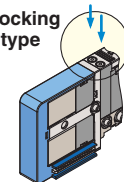

Push-turn locking slotted type

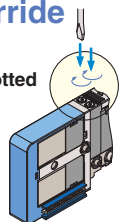

Manual button will hold the pushed (ON) status.

Light indication

SOL.A: ON Orange
SOL.B: ON Green

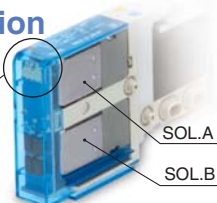

Connector mounting direction

Connector mounting direction can be changed by sliding the switch.

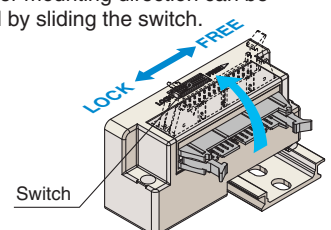

4 Port Solenoid Valve Cassette Type Manifold



EX180
Serial wiring

Flat ribbon cable

EX510 Gateway system
Serial transmission system

Actual size

Series SJ2000/3000

EX180 Serial wiring

- CC-Link (32 outputs), DeviceNet (32, 16 outputs)
- Easy attaching/detaching of the SI unit and wiring by connectors
- Separated valve power unit and transmission power unit / Ensuring safety at maintenance.
- Selectable between T-branch and straight type of communication connector.

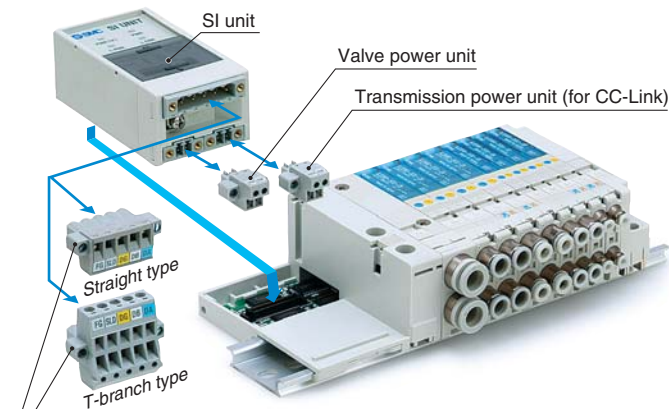

Communication connector

In case of DeviceNet, transmission power unit exists in the communication connector side of T-branch or straight type.

EX510 Gateway system Serial transmission system

- Max. 128 points (Input 64 points/Output 64 points)
- All wires can be plugged into the connector units
- CC-Link, DeviceNet, and PROFIBUS-DP compliant



System Configuration

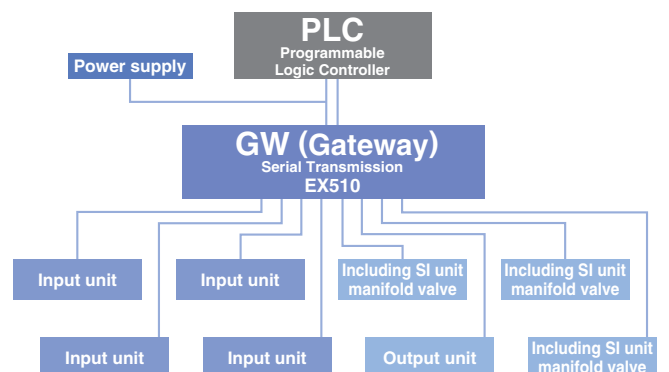

4 Position Dual 3 Port Valve

- Integrated to a single valve from 3-port valve.
- Possible to control 4(A), 2(B) port individually.
- Can be mounted on the same manifold with a 4-port valve.
- Prepared 3 types of combination.
- Label with the same colours of the manual override is attached to show the functions of A side and B side.

A side	B side	JIS symbol
N.C. valve	N.C. valve	
N.O. valve	N.O. valve	
N.C. valve	N.O. valve	

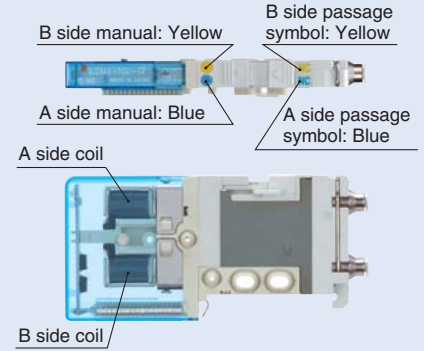

Regulator Block New Details → Page 63

Block with same width (10 mm) as the SJ3000.
 Pressure supplied from the D side is used to reduce pressure in the manifold.
 U side valves are all depressurized from the regulator block.

Pneumatic circuit (example of regulator block installation):

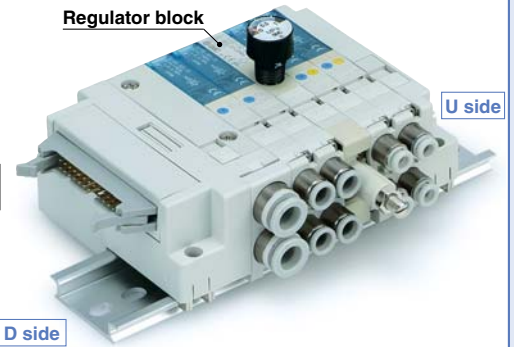
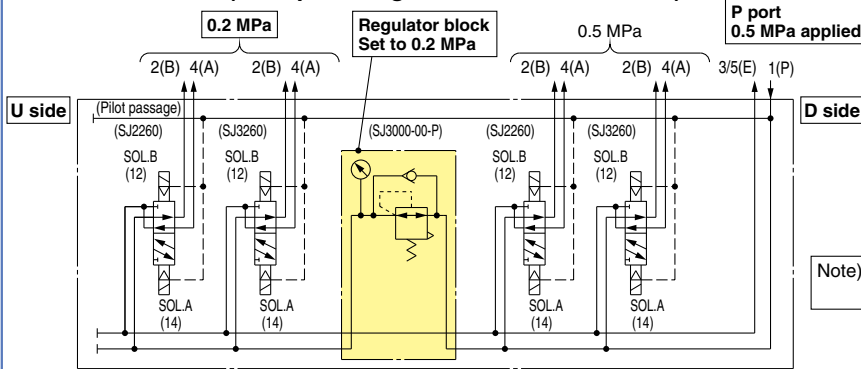

Note) Reduces supply pressure from the D side of the manifold.
 Supply pressure from the U side cannot be reduced.

Both the pressure gauge mounting position and the pressure adjustment screw operating method can be selected.

SJ3000-00-P(-H)

SJ3000-01-P(-H)

SJ3000-M1-P(-H)

With manual operation of the pressure adjustment screw

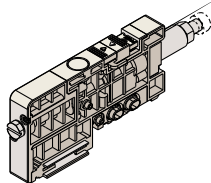
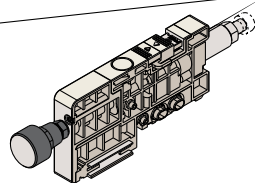
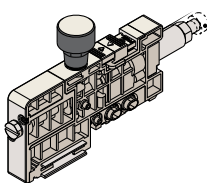

Pressure gauge, top mounting

Pressure gauge, side mounting

Without pressure gauge

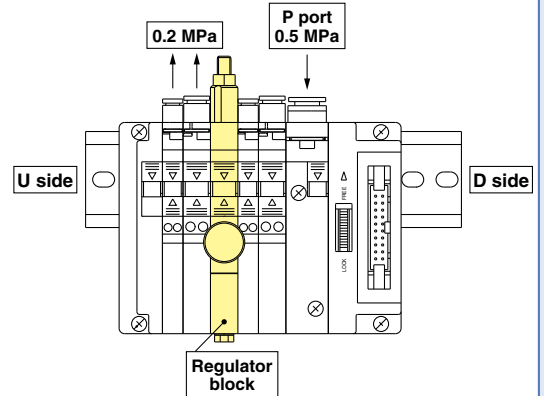

Intermediate Connector Block Assembly New Details → Page 64

Block that can be used by inserting it into the middle of the manifold.
 It can be used, for example, to separate electrical control of valves in the same manifold, or when the number of control points is insufficient.
 The assembly is also compatible with PC wiring with the power supply terminal.
 (Consult SMC separately.)

Intermediate connector block assembly wiring example:

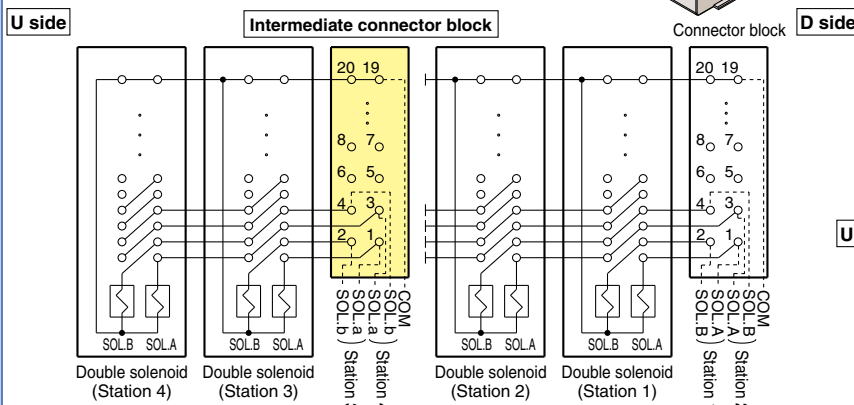

Note) The U side solenoid valves can be controlled from the position where the intermediate connector block assembly is mounted.

Intermediate connector block assembly

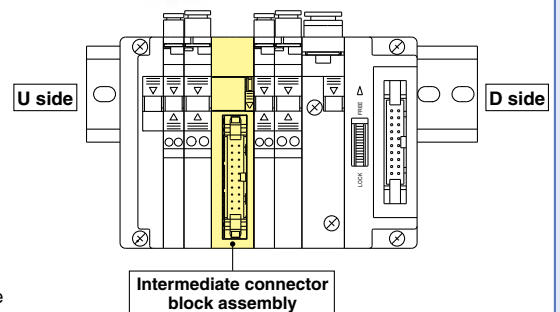
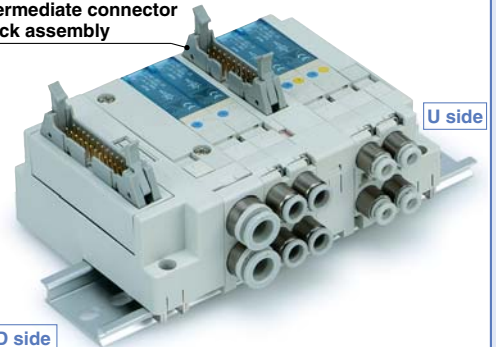

Vacuum Release Valve with Restrictor C €

Two spool valves are built-in.
Vacuum suction and release can be controlled with a single valve.

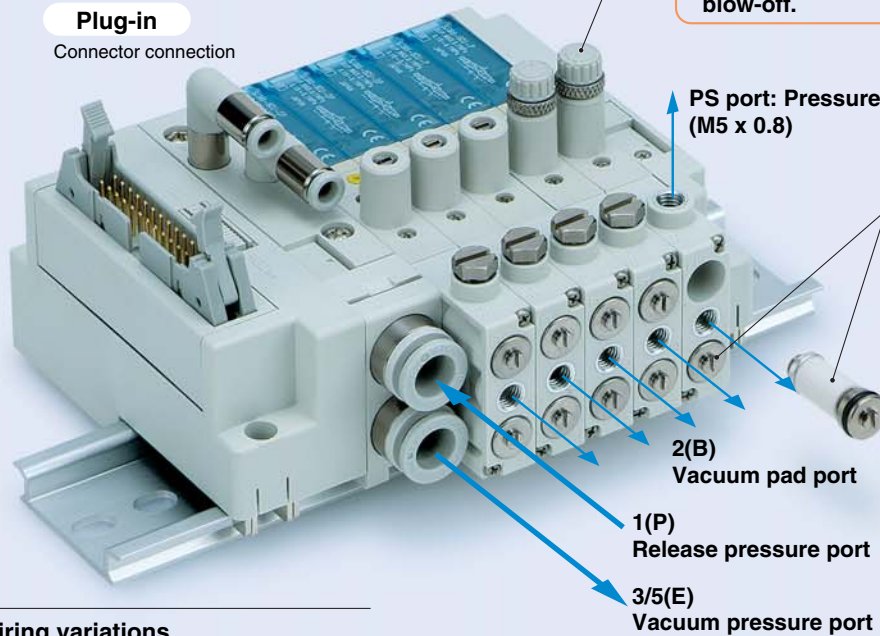

Plug-in

Connector connection

Restrictor

- Flow rate adjustment of release air.
- Prevents workpiece blow-off.

Manual

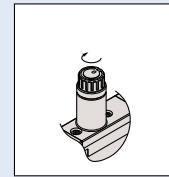

Slotted locking type

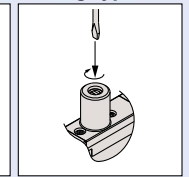

Filter

- Eliminates foreign matter on vacuum and release side.
- Replaceable.

Wiring variations

- D-sub connector
- Flat ribbon cable
- PC wiring
- Serial (EX180)
- Serial (EX510)

Non-plug-in

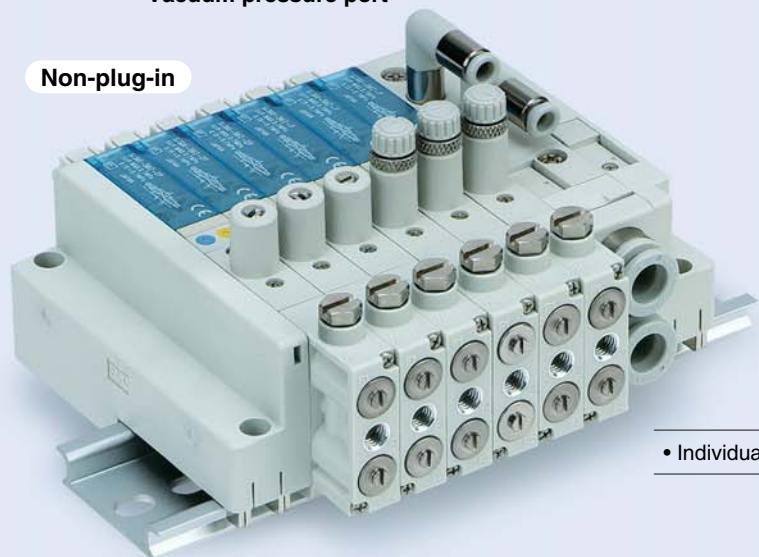

• Individual wiring

Series SJ3A6

- Power consumption: **0.15 W** (with power saving circuit).
- **Width: 10 mm** (same size as SJ3000 series).
- Equipped with restrictor to enable flow rate adjustment of release air.
- Replaceable filters are built-in on vacuum and release sides.
- Equipped with a pressure detection port enabling, for example, the connection of a pressure switch.
- Can be **combined** with 4 port solenoid valve, SJ2000/3000 series (Made to Order). (Consult SMC for details.)
- Enables **2-system pressure** switching where 1(P) and 3/5(E) ports are set to different positive pressures. (In this case, flow can be only adjusted on the P-port side.)

Adsorbing and Transferring System Circuit Example

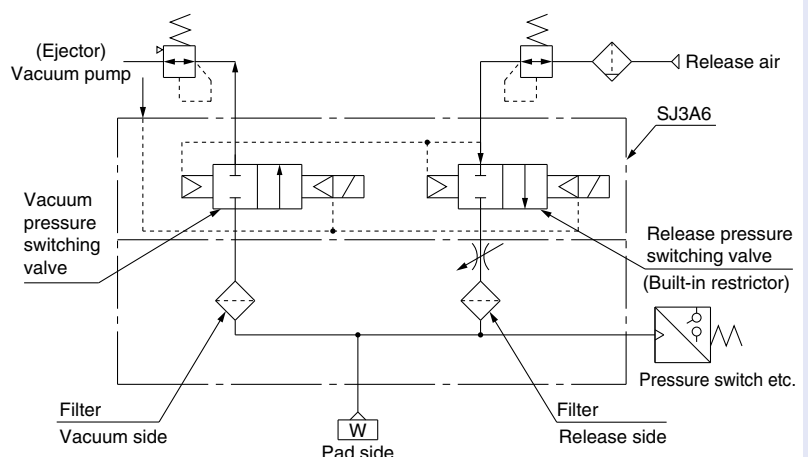

INDEX

● 4 Port Solenoid Valve *Series SJ2000/3000*

Common Specifications	P.1
Connector Wiring Diagram	P.3
Construction	P.4

Plug-in Connector Type Manifold

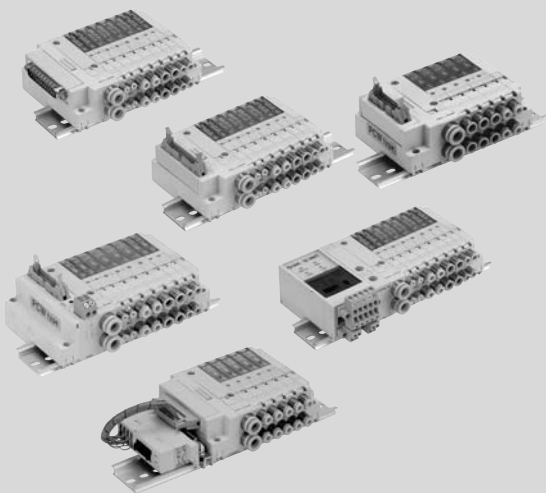

D-sub Connector / Flat Ribbon Cable / PC Wiring	
How to Order	P.10
Manifold Electrical Wiring	P.12
Dimensions	P.13
PC Wiring System with Power Supply Terminal	
How to Order	P.26
Manifold Electrical Wiring	P.28
Dimensions	P.29
EX180 Serial Wiring	
How to Order	P.34
Dimensions	P.36
EX510 Gateway System Serial Transmission System	
How to Order Manifold	P.42
Dimensions	P.44
Manifold Exploded View	P.49
How to Add Manifold Stations	P.50

Non-plug-in Individual Wiring Manifold



Individual Wiring	
How to Order	P.52
Dimensions	P.54
Manifold Exploded View	P.59
Manifold Options	P.60
Made to Order	P.65

● Vacuum Release Valve with Restrictor *Series SJ3A6*

Common Specifications	P.68
Construction	P.69

Plug-in Connector Type Manifold

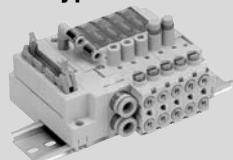

D-sub Connector / Flat Ribbon Cable / PC Wiring / Serial Wiring (EX180/EX510)	
How to Order	P.70
Dimensions	P.72

Non-plug-in Individual Wiring Manifold



Individual Wiring	
How to Order	P.74
Dimensions	P.76
Manifold Exploded View	P.77

Safety Instructions	Back page 1
Specific Product Precautions	Back page 3

4 Port Solenoid Valve Common Specifications

Series SJ2000/3000



Manifold Specifications

Model	D-sub connector		Flat ribbon cable			Serial wiring		Individual wiring
	Type 60F	Type 60P	Type 60PG Type 60J Type 60G	Type 60PH	Type 60S□ (EX180)	Type 60S6B (EX510)	Type 60	
Manifold type	Plug-in, Connector type							Non-plug-in
1(P: SUP), 3/5(E: EXH)	Common SUP, EXH							
Valve stations	2 to 24 stations		2 to 18 stations (Type PG) 2 to 16 stations (Type J, Type G)	2 to 8 stations	2 to 32 stations	2 to 16 stations	2 to 20 stations	
Applicable connector	D-sub connector Conforming to (MIL-C-24308 JIS-X-5101)	Flat ribbon cable connector Socket: 26 pins MIL type with strain relief (Conforming to MIL-C-83503)	Flat ribbon cable connector Socket: 20 pins MIL type with strain relief (Conforming to MIL-C-83503)	Flat ribbon cable connector Socket: 10 pins MIL type with strain relief (Conforming to MIL-C-83503)	—	—	—	
Internal wiring	Non-polar, +COM / -COM							
4(A), 2(B) port piping spec.	Location	Valve						
	Direction	Horizontal, Upward, Downward (with elbow fittings when using upward or downward)						
Port size	1(P), 3/5(E) port		C6, C8, N7, N9 (Inch size elbow fitting is not available.)					
	4(A), 2(B) port	SJ2000	C2, C4, N1, N3, M3					
		SJ3000	C2, C4, C6, N1, N3, N7, M5					
Weight W (g) ^{Note 2)} n: Number of SUP/EXH blocks m: Weight of DIN rail		$W = 51n + m + 133$						

Note 1) When many valves are operated simultaneously, use B type (SUP/EXH both sides), applying pressure to the 1(P) ports on both sides and exhaust from the 3/5(E) ports on both sides.

Note 2) The weight W is the value for the D-sub connector manifold only with internal pilot, SUP/EXH block straight fittings specifications. To obtain the weight with solenoid valves attached, add the solenoid valve weights given on page 3 for the appropriate number of stations. Refer to page 61 for the weight of DIN rail. (Please contact SMC for the weight of external pilot specifications, elbow fittings.)

Flow Characteristics

SJ2000

Port size		Flow characteristics					
1(P) 3/5(E)	4, 2 (A, B)	1→2/4 (P→A/B)			4/2→3/5 (A/B→E)		
		C [dm ³ /(s·bar)]	b	Cv	C [dm ³ /(s·bar)]	b	Cv
C8	C2	0.13	0.55	0.04	0.13	0.50	0.04
	C4	0.33	0.16	0.08	0.36	0.13	0.08
	M3	0.18	0.52	0.06	0.20	0.29	0.06

SJ3000

Port size		Flow characteristics					
1(P) 3/5(E)	4, 2 (A, B)	1→2/4 (P→A/B)			4/2→3/5 (A/B→E)		
		C [dm ³ /(s·bar)]	b	Cv	C [dm ³ /(s·bar)]	b	Cv
C8	C2	0.13	0.56	0.04	0.14	0.51	0.04
	C4	0.42	0.17	0.11	0.45	0.16	0.11
	C6	0.55	0.10	0.12	0.56	0.11	0.12
	M5	0.40	0.28	0.11	0.45	0.15	0.11

Note) The value is for manifold base with 5 stations and individually operated 2 position type.
Please contact SMC for 4 position dual 3 port valves.

Series SJ2000/3000

Solenoid Valve Specifications



D-sub connector



Flat ribbon cable

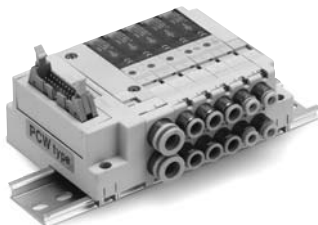

PC wiring



Serial wiring: EX180

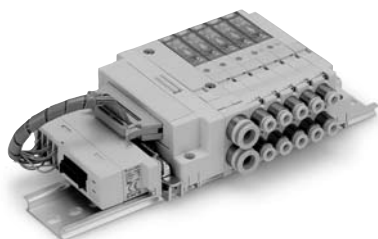

Gateway system
Serial transmission system: EX510



Individual wiring

Fluid		Air	
Internal pilot operating pressure range (MPa)	2 position single	0.15 to 0.7	
	4 position dual 3 port valve	0.1 to 0.7	
	2 position double	0.2 to 0.7	
	3 position	0.2 to 0.7	
External pilot operating pressure range (MPa)	Operating pressure range		-100 kPa to 0.7
	Pilot pressure range	2 position single	0.25 to 0.7
		2 position double	
3 position			
Ambient and fluid temperature (°C)		-10 to 50 (No freezing)	
Maximum operating frequency (Hz)	2 position single, double	10	
	4 position dual 3 port valve	3	
	3 position	3	
Manual override (Manual operation)		Non-locking push type Push-turn locking slotted type	
Pilot exhaust method	Internal pilot	Main and pilot valve common exhaust	
	External pilot	Pilot valve individual exhaust	
Lubrication		Not required	
Mounting orientation		Unrestricted	
Shock/Vibration resistance (m/s²)		150/30	
Enclosure		Dustproof	

Note) Impact resistance: No malfunction occurred when it is tested with a drop tester in the axial direction and at the right angles to the main valve and armature in both energised and de-energised states every once for each condition. (Value in the initial state)

Vibration resistance: No malfunction occurred in one sweep test between 45 and 2000Hz. Test was performed to axis and right angle directions of the main valve when pilot signal is ON and OFF. (Value in the initial state)

Solenoid Specifications

Coil rated voltage		24 VDC, 12 VDC	
Allowable voltage fluctuation		±10% of rated voltage*	
Power consumption (W)	Standard	SJ2000	0.55
		SJ3000	0.4
	With power saving circuit (Continuous duty type)	SJ2000	0.23
		SJ3000	0.15
Surge voltage suppressor		Diode	
Indicator light		LED	

Note) For the allowable voltage fluctuation for Z and T types (with power saving circuit), please observe the following range because they have voltage drop due to internal circuit.

Z type 24 VDC: -7% to +10%
12 VDC: -4% to +10%
T type 24 VDC: -5% to +10%
12 VDC: -6% to +10%

Response Time

Type of actuation	Response time ms (at 0.5 MPa)	
	SJ2000	SJ3000
2 position single	16 or less	16 or less
2 position double	10 or less	10 or less
3 position	34 or less	22 or less
4 position dual 3 port valve	30 or less	30 or less

Note) Based on dynamic performance test, JIS B 8375-1981. (Coil temperature: 20°C, at rated voltage)

Weight

Model/SJ2000

Valve model	Type of actuation	Port size 4(A), 2(B)	Weight (g)	
SJ2□60-C2	2 position	C2 (ø2 one-touch fitting)	Single	43
			Double	46
	3 position		Closed centre	50
			Exhaust centre	
			Pressure centre	
4 position	Dual 3 port valve	46		
SJ2□60-C4	2 position	C4 (ø4 one-touch fitting)	Single	41
			Double	44
	3 position		Closed centre	48
			Exhaust centre	
			Pressure centre	
	4 position		Dual 3 port valve	44
	SJ2□60-M3		2 position	M3 x 0.5
Double		42		
3 position		Closed centre	46	
		Exhaust centre		
		Pressure centre		
4 position		Dual 3 port valve	42	

Note) Please contact SMC for the weight of elbow fittings.

Model/SJ3000

Valve model	Type of actuation	Port size 4(A), 2(B)	Weight (g)	
SJ3□60-C2	2 position	C2 (ø2 one-touch fitting)	Single	63
			Double	71
	3 position		Closed centre	75
			Exhaust centre	
			Pressure centre	
	4 position		Dual 3 port valve	71
SJ3□60-C4	2 position	C4 (ø4 one-touch fitting)	Single	65
			Double	73
	3 position		Closed centre	77
			Exhaust centre	
			Pressure centre	
	4 position		Dual 3 port valve	73
	SJ3□60-C6		2 position	C6 (ø6 one-touch fitting)
Double		69		
3 position		Closed centre	73	
		Exhaust centre		
		Pressure centre		
4 position		Dual 3 port valve	69	
SJ3□60-M5	2 position	M5 x 0.8	Single	57
			Double	65
	3 position		Closed centre	69
			Exhaust centre	
			Pressure centre	
	4 position		Dual 3 port valve	65

Note) Please contact SMC for the weight of elbow fittings.

Connector Wiring Diagram

For both serial and parallel wiring, additional valves are sequentially assigned pins on the connector. This makes it completely unnecessary to disassemble the connector unit.

Single solenoid and double solenoid

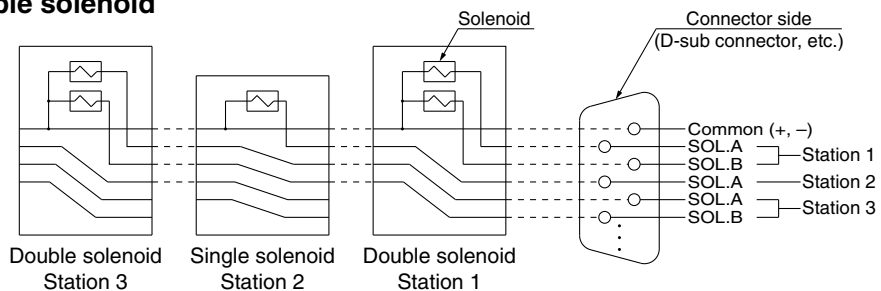

Single solenoid with double wiring spec.

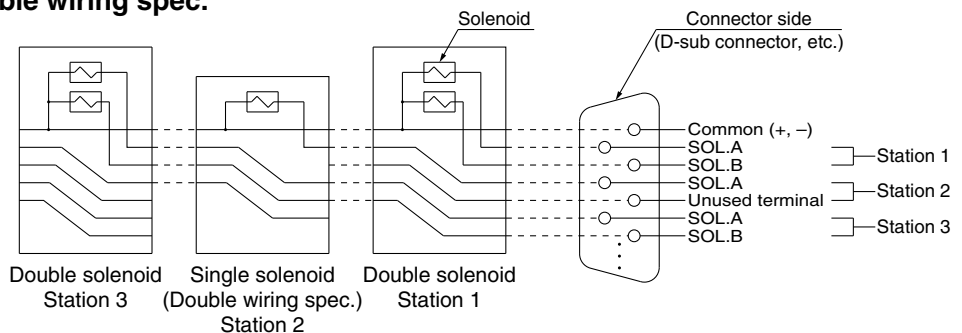

Mounting a valve with individual wiring

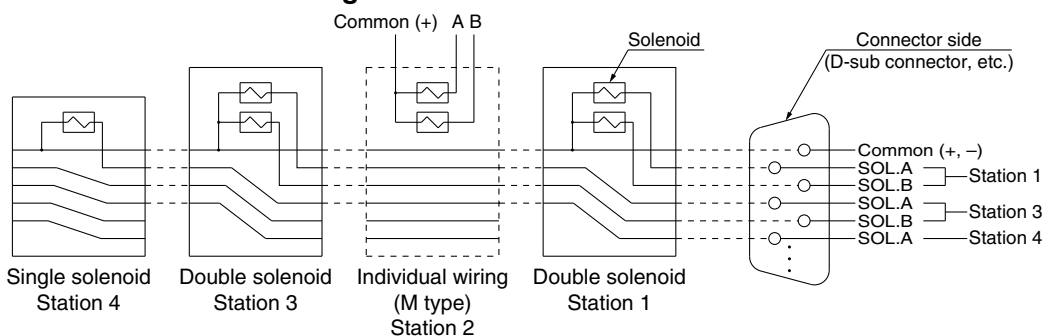

Series SJ2000/3000

Construction: SJ2000

JIS symbol

2 position single

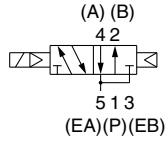

2 position single with back pressure check valve

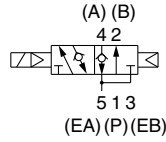

2 position double

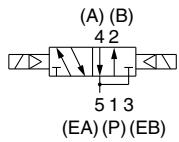

2 position double with back pressure check valve

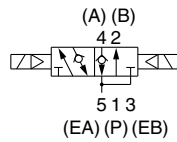

3 position closed centre

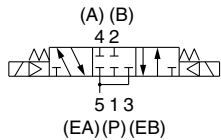

3 position exhaust centre

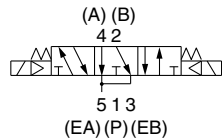

3 position pressure centre

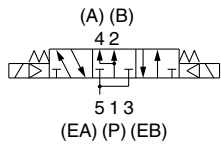

2 position single

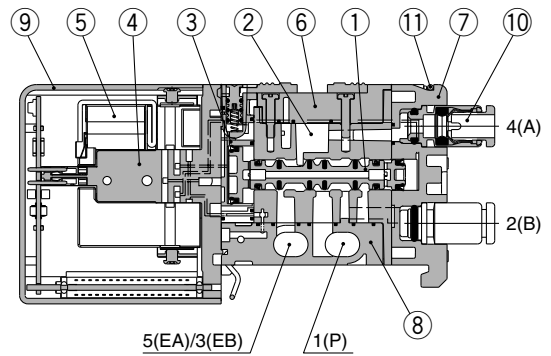

2 position double

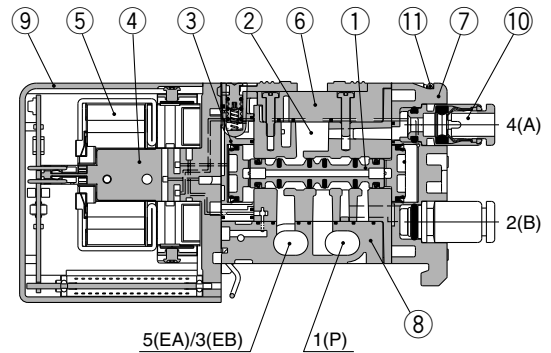

3 position closed centre/exhaust centre/pressure centre

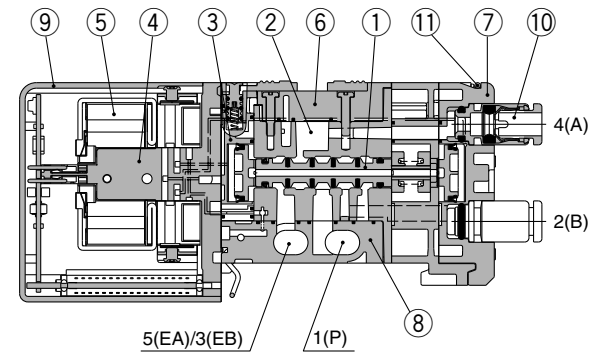

Component Parts

No.	Description	Material	Note
1	Spool valve assembly	Resin/H-NBR (3 position solenoid valve: Aluminum/H-NBR)	—
2	Body	Zinc die-cast	—
3	Adaptor plate	Resin	White
4	Pilot adaptor	Resin	White
5	Pilot valve assembly	—	—
6	Body cover	Resin	White
7	Port block	Resin	White
8	Bottom cover	Resin	White
9	Light cover	Resin	Light blue

Replacement Parts

No.	Description	Part no.
10	One-touch fitting	Refer to the one-touch fitting part no. on back page 6.
11	Clip	SJ2000-CL-1 (10 pcs.)

SJ2260K with back pressure check valve

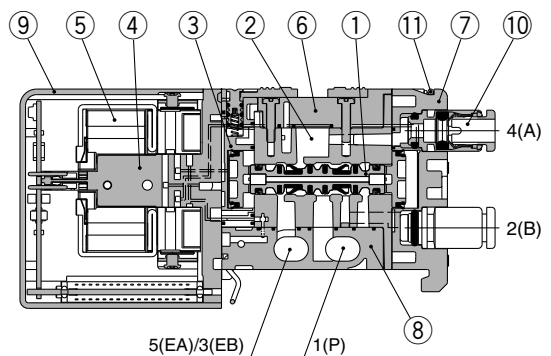

Construction: SJ2000

JIS symbol

4 position dual 3 port valve SJ2A60 [N.C. valve x 2]

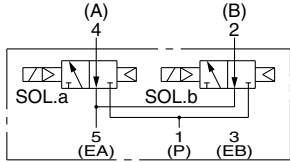

SJ2A60K with back pressure check valve

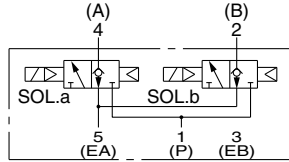

SJ2A60 [N.C. valve x 2]

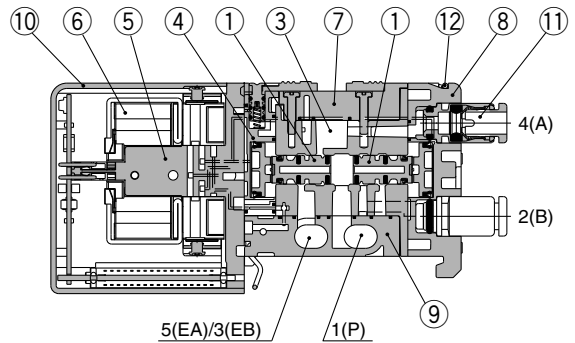

SJ2B60 [N.O. valve x 2]

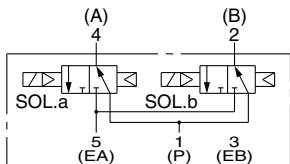

SJ2B60K with back pressure check valve

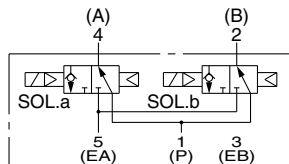

SJ2B60 [N.O. valve x 2]

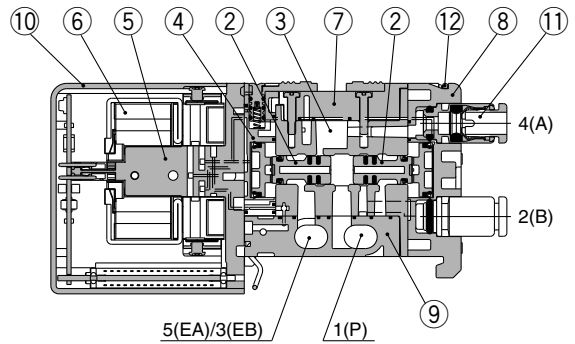

SJ2C60 [N.C., N.O. valve x 1 (each)]

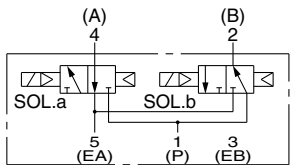

SJ2C60K with back pressure check valve

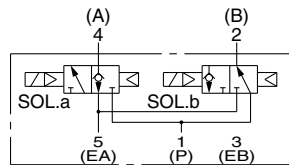

SJ2C60 [N.C. valve, N.O. valve x 1 (each)]

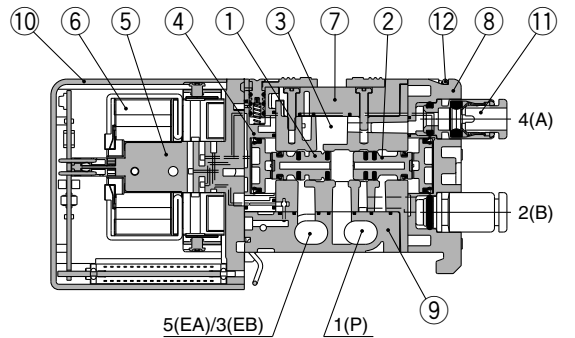

Component Parts

No.	Description	Material	Note
1	Spool valve assembly	Resin/H-NBR	N.C. (Normally closed)
2	Spool valve assembly	Resin/H-NBR	N.O. (Normally open)
3	Body	Zinc die-cast	—
4	Adaptor plate	Resin	White
5	Pilot adaptor	Resin	White
6	Pilot valve assembly	—	—
7	Body cover	Resin	White
8	Port block	Resin	White
9	Bottom cover	Resin	White
10	Light cover	Resin	Light blue

Replacement Parts

No.	Description	Part no.
11	One-touch fitting	Refer to the one-touch fitting part no. on back page 6.
12	Clip	SJ2000-CL-1 (10 pcs.)

SJ2A60K with back pressure check valve

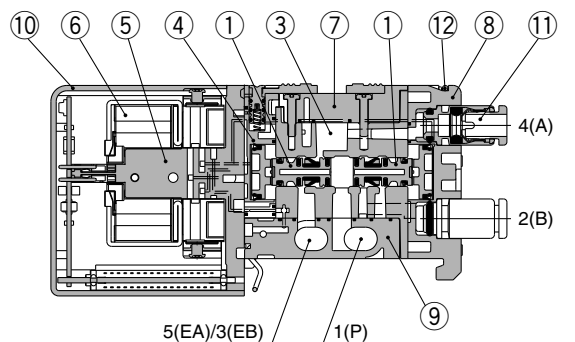

Series SJ2000/3000

Construction: SJ3000

JIS symbol

2 position single

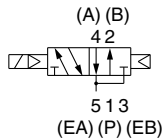

2 position single with back pressure check valve

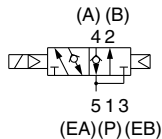

2 position single

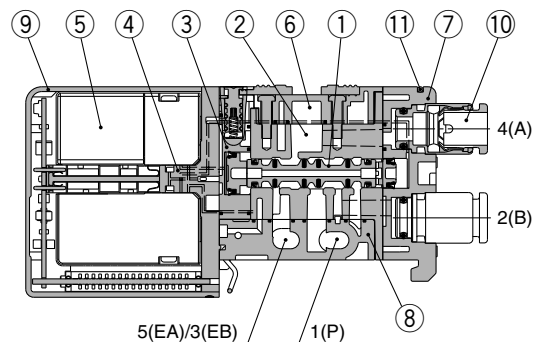

2 position double

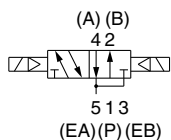

2 position double with back pressure check valve

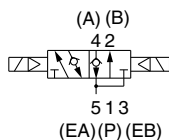

2 position double

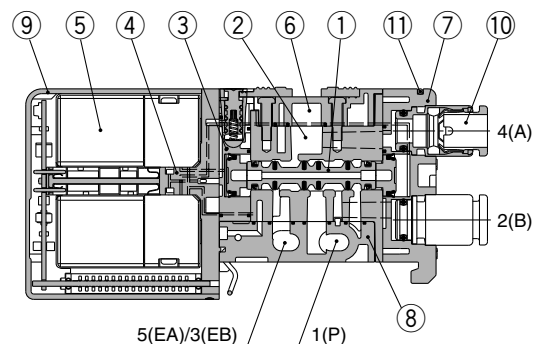

3 position closed centre

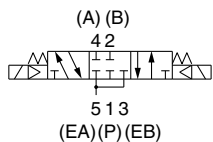

3 position exhaust centre

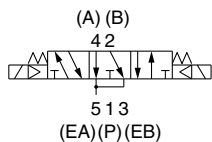

3 position closed centre/exhaust centre/pressure centre

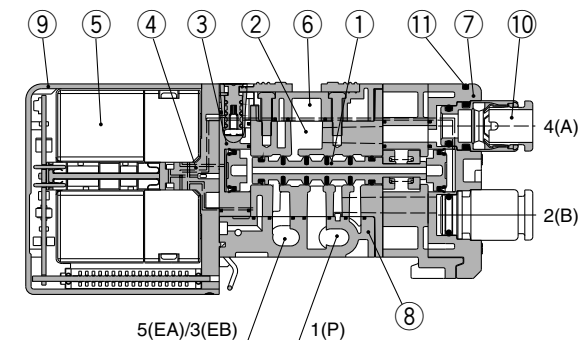

3 position pressure centre

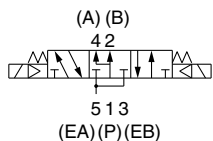

Component Parts

No.	Description	Material	Note
1	Spool valve assembly	Resin/H-NBR (3 position solenoid valve: Aluminum/H-NBR)	—
2	Body	Zinc die-cast	—
3	Adaptor plate	Resin	White
4	Pilot adaptor	Resin	White
5	Pilot valve assembly	—	—
6	Body cover	Resin	White
7	Port block	Resin	White
8	Bottom cover	Resin	White
9	Light cover	Resin	Light blue

Replacement Parts

No.	Description	Part no.
10	One-touch fitting	Refer to the one-touch fitting part no. on back page 6.
11	Clip	SJ3000-CL-1 (10 pcs.)

SJ3260K with back pressure check valve

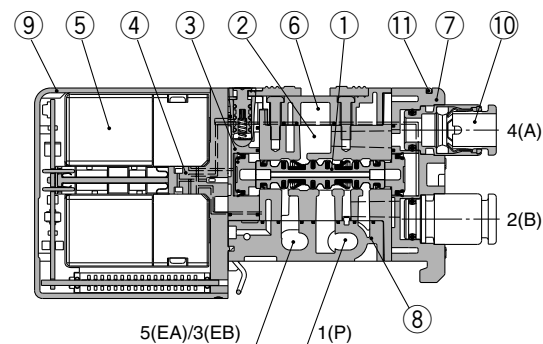

Construction: SJ3000

JIS symbol

4 position dual 3 port valve
SJ3A60 [N.C. valve x 2]

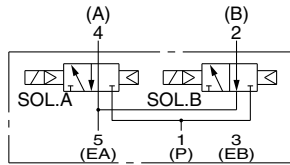

SJ3A60K with back pressure check valve

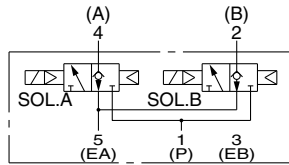

SJ3A60 [N.C. valve x 2]

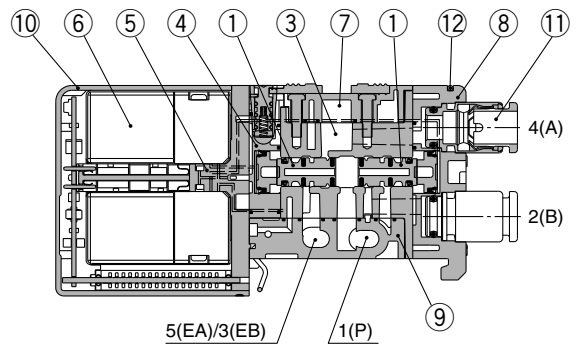

SJ3B60 [N.O. valve x 2]

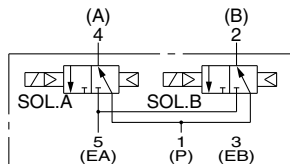

SJ3B60K with back pressure check valve

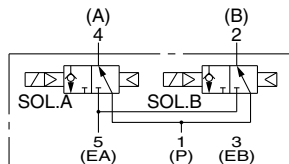

SJ3B60 [N.O. valve x 2]

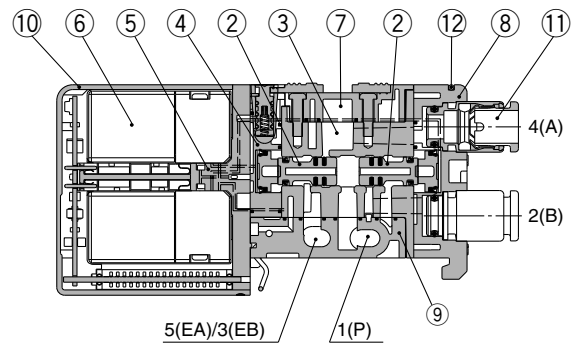

SJ3C60 [N.C., N.O. valve x 1 (each)]

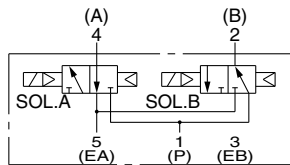

SJ3C60K with back pressure check valve

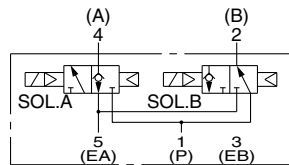

SJ3C60 [N.C. valve, N.O. valve x 1 (each)]

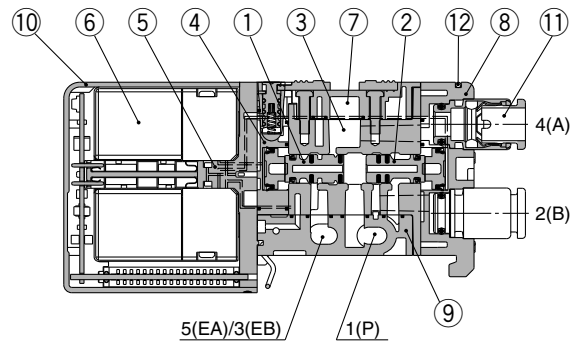

Component Parts

No.	Description	Material	Note
1	Spool valve assembly	Resin/H-NBR	N.C. (Normally closed)
2	Spool valve assembly	Resin/H-NBR	N.O. (Normally open)
3	Body	Zinc die-cast	—
4	Adaptor plate	Resin	White
5	Pilot adaptor	Resin	White
6	Pilot valve assembly	—	—
7	Body cover	Resin	White
8	Port block	Resin	White
9	Bottom cover	Resin	White
10	Light cover	Resin	Light blue

Replacement Parts

No.	Description	Part no.
11	One-touch fitting	Refer to the one-touch fitting part no. on back page 6.
12	Clip	SJ3000-CL-1 (10 pcs.)

SJ3A60K with back pressure check valve

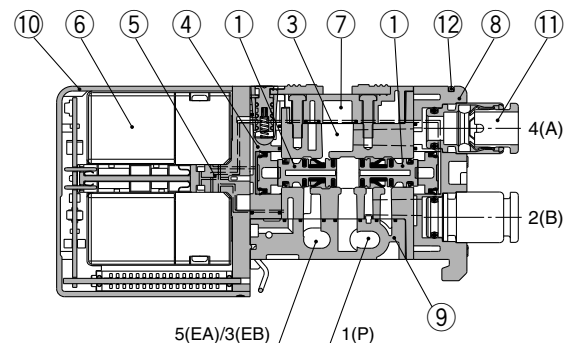

Plug-in Connector Type Manifold

Series SJ2000/3000

P.10 D-sub Connector / Flat Ribbon Cable / PC Wiring

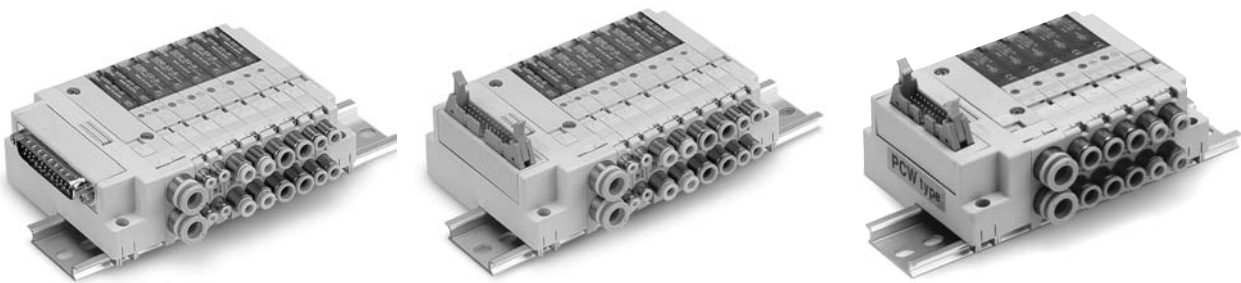

P.26 PC Wiring System with Power Supply Terminal

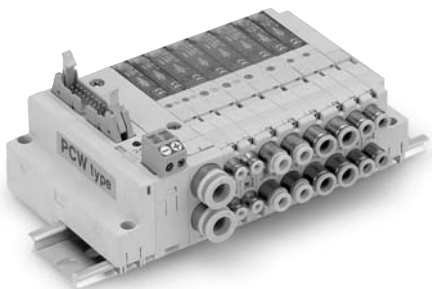

P.34 Serial Wiring: EX180



P.42 Gateway System Serial Transmission System: EX510

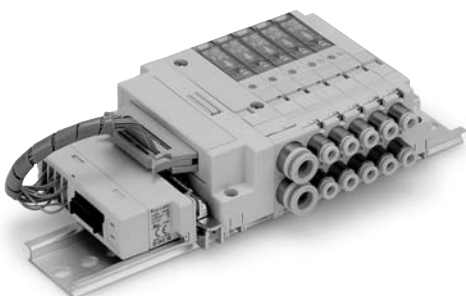

Plug-in Connector Type

D-sub Connector / Flat Ribbon Cable / PC Wiring

Series SJ2000/3000



How to Order

● Connector type manifold

SS5J3 - 60FD1 - 05U

2	SJ2000
3	SJ3000 (SJ2000/3000 mixed)

Mixed mounting type

—	Standard <small>Note 1)</small>
M	Mixed mounting <small>Note 2)</small>

Note 1) There is no need to enter anything when you order either the SJ2000 or SJ3000 series alone.

Note 2) Enter "M" when the SJ2000 or SJ3000 series will be mounted on the same manifold base together.

Connector mounting position

Symbol	Mounting position
D	D side

Connector entry direction

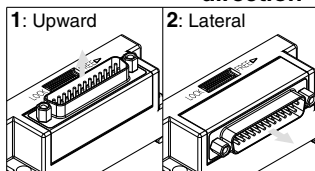

Connector type

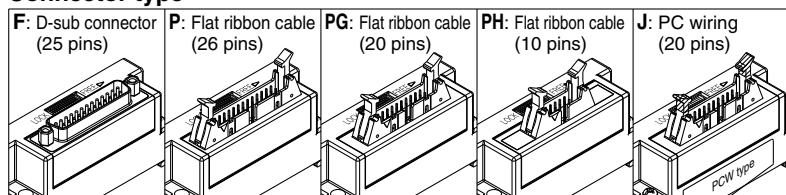

How to Order Valve Manifold Assembly

Ordering example (SS5J3-60PD2-□)

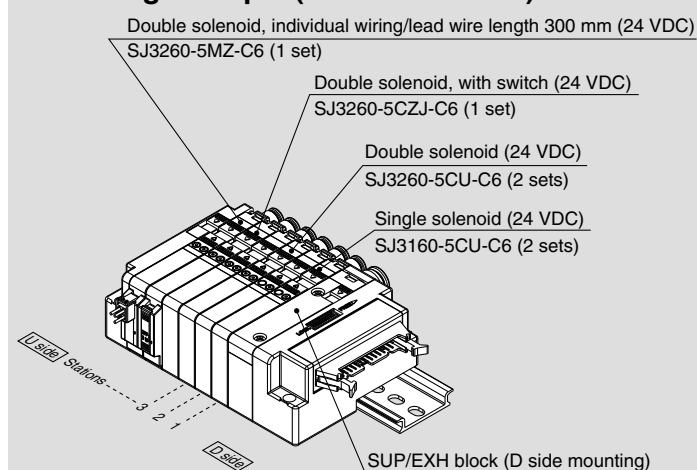

SS5J3-60PD2-06D 1 set (Manifold part no.)

* SJ3160-5CU-C6 2 sets (Single solenoid part no.)

* SJ3260-5CU-C6 2 sets (Double solenoid part no.)

* SJ3260-5CZJ-C6 1 set (Double solenoid, with switch part no.)

* SJ3260-5MZ-C6 1 set (Double solenoid, individual wiring/lead wire length 300 mm part no.)

— The asterisk denotes the symbol for assembly.
Prefix to the part no. of the solenoid valve, etc.

- The valve arrangement is numbered as the 1st station from D side.
- Indicate the valves to be attached below the manifold part number, in order starting from station 1 as shown in the drawing.
- In the case of complex arrangement, specify them in the manifold specification sheet.

DIN rail length specified

—	Standard length	
3	3 stations	Specify a longer rail than the standard length.
⋮	⋮	
24	24 stations	

Note) Specify the valve stations not exceeding the maximum stations.

● SUP/EXH block fitting spec.

—	Straight fitting	
—	With external pilot spec. X, PE port	
L	Elbow fitting (Upward)	
L	With external pilot spec. X, PE port	
B	Elbow fitting (Downward)	
B	With external pilot spec. X, PE port	

Note) There is no need to enter anything when the SUP/EXH block mounting position "M" is selected.

● Pilot spec.

—	Internal pilot
S	Internal pilot / Built-in silencer
R	External pilot
RS	External pilot / Built-in silencer

Note 1) There is no need to enter anything when the SUP/EXH block mounting position "M" is selected.

Note 2) For built-in silencers, the 3/5(E) ports are plugged.

● SUP/EXH block mounting position

U	U side (2 to 10 stations)
D	D side (2 to 10 stations)
B	Both sides (2 to 24 stations)
M <small>Note)</small>	Special specifications

Note) Specify the required specifications (including port sizes other than ø8) by using a manifold specification sheet.

● Valve stations

F: D-sub connector

Symbol	Stations	Note
02	2 stations	Up to 24 solenoids possible.
⋮	⋮	
24	24 stations	

PG: Flat ribbon cable (20 pins)

Symbol	Stations	Note
02	2 stations	Up to 18 solenoids possible.
⋮	⋮	
18	18 stations	

Note) The number of the blanking block assembly is also included. Since single and double wiring are available with the blanking block assembly, select a model compatible with the valve wiring spec. planned for the future. (Refer to page 61.)

P: Flat ribbon cable (26 pins)

Symbol	Stations	Note
02	2 stations	Up to 24 solenoids possible.
⋮	⋮	
24	24 stations	

PH: Flat ribbon cable (10 pins)

Symbol	Stations	Note
02	2 stations	Up to 8 solenoids possible.
⋮	⋮	
08	8 stations	

J: PC wiring (20 pins)

Symbol	Stations	Note
02	2 stations	Up to 16 solenoids possible.
⋮	⋮	
16	16 stations	

Refer to page 26 through to 33 for PCW type with power supply terminal.

How to Order Solenoid Valves

Standard	SJ 3 1 60 [] [] [] - 5 [] C U [] - C6 - []
With switch	SJ 3 1 60 [] [] [] - 5 [] C Z J [] - C6 - []
Individual wiring [For plug-in mixed mounting] <small>Note)</small>	SJ 3 1 60 [] [] [] - 5 [] M Z [] - C6

Note) Refer to pages 52 and 53 for the dedicated non-plug-in individual wiring.

Series

2	SJ2000
3	SJ3000

Back pressure check valve

—	None
K	Built-in

Note) Back pressure check valve is not applicable for 3 position valve.

Pilot spec.

—	Internal pilot
R	External pilot

Note) External pilot spec. is not applicable for 4 position dual 3 port valves.

Coil spec.

—	Standard
T	With power saving circuit (continuous duty type)

Note) Be sure to select "with power saving circuit" when the solenoid valve will be energised continuously for long period.

Type of actuation

1	2 position single solenoid
2	2 position double solenoid
3	3 position closed centre
4	3 position exhaust centre
5	3 position pressure centre
A	Dual 3 port valve: N.C./N.C.
B	Dual 3 port valve: N.O./N.O.
C	Dual 3 port valve: N.C./N.O.

Note) Refer to pages 4 through to 7 for the JIS symbol.

Rated voltage

5	24 VDC
6	12 VDC

Common spec.

—	Positive common
N	Negative common

Note) Select nothing for non polar type

Single solenoid wiring spec.

—	Single wiring
D	Double wiring

Note) There is no need to enter anything for 2 position double, 3 position and 4 position solenoid valves. Select this when the unused numbers to wiring are set. Refer to page 3 for details.

Connector entry

C: Dedicated for centralised wiring

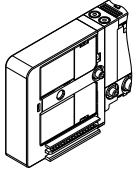

M: Individual wiring, with lead wire
Length 300 mm

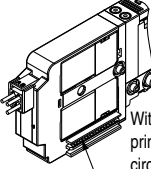

MN: Individual wiring, without lead wire (with connector, socket)

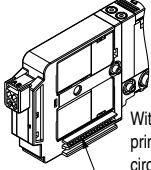

MO: Individual wiring, without connector

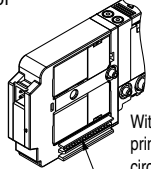

Light/surge voltage suppressor

U	With light/surge voltage suppressor (non-polar type)
Z	With light/surge voltage suppressor (polar type)

Note 1) When the types with power saving circuit, with switches, and individual wiring are used, the non-polar type cannot be selected.

With switch

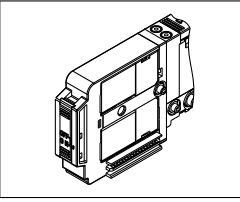

Manual override

—: Non-locking push type

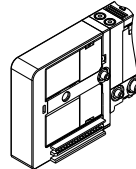

D: Push-turn locking slotted type

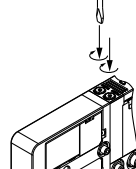

Note 1) Connector entries with the symbol "M□" can not use the switch signal from the common wiring on the manifold. For details, refer to "Connector Wiring Diagram" on page 3.
Note 2) When ordering a connector assembly separately, refer to back page 8.

A, B port size

Straight (Metric size)

C2: ø2 one-touch fitting

C4: ø4 one-touch fitting

C6: ø6 one-touch fitting (SJ3000 only)

(Inch size)

N1: ø1/8" one-touch fitting

N3: ø5/32" one-touch fitting

N7: ø1/4" one-touch fitting (SJ3000 only)

(Thread piping)

M3: M3 x 0.5 (SJ2000 only)

M5: M5 x 0.8 (SJ3000 only)

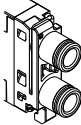

Elbow fitting assembly (upward entry) (Metric size)

L2: ø2 one touch fitting

L4: ø4 one touch fitting

L6: ø6 one touch fitting (SJ3000 only)

(Inch size)

LN1: ø1/8" one touch fitting

LN3: ø5/32" one touch fitting

LN7: ø1/4" one touch fitting (SJ3000 only)

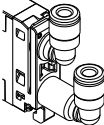

Elbow fitting assembly (downward entry) (Metric size)

B2: ø2 one touch fitting

B4: ø4 one touch fitting

B6: ø6 one touch fitting (SJ3000 only)

(Inch size)

BN1: ø1/8" one touch fitting

BN3: ø5/32" one touch fitting

BN7: ø1/4" one touch fitting (SJ3000 only)

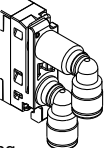

Series SJ2000/3000

Manifold Electrical Wiring (Non-polar type)

Type 60F: D-sub connector (25 pins)

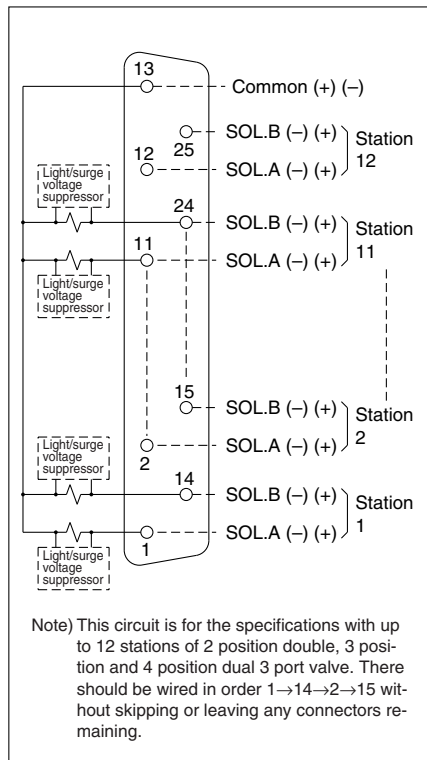

Type 60P: Flat ribbon cable (26 pins)

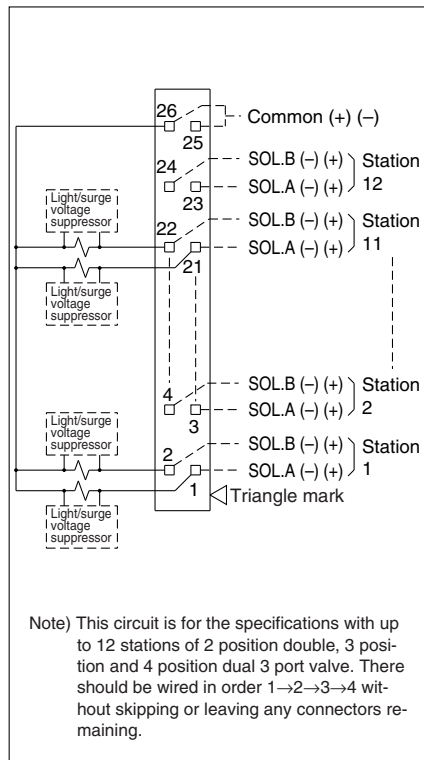

Type 60PG: Flat ribbon cable (20 pins)

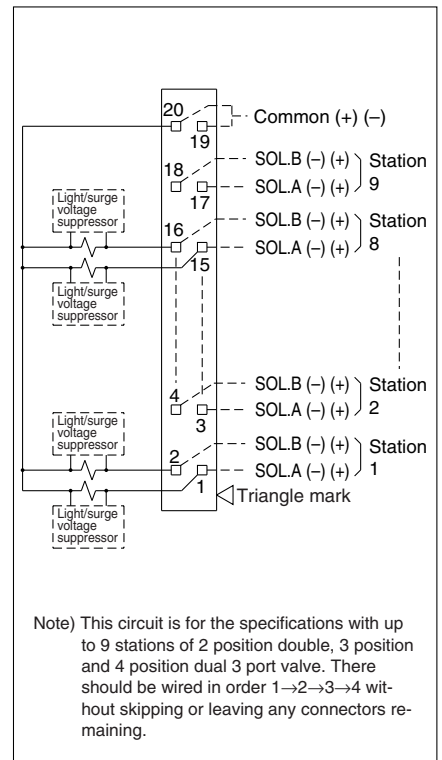

Type 60PH: Flat ribbon cable (10 pins)

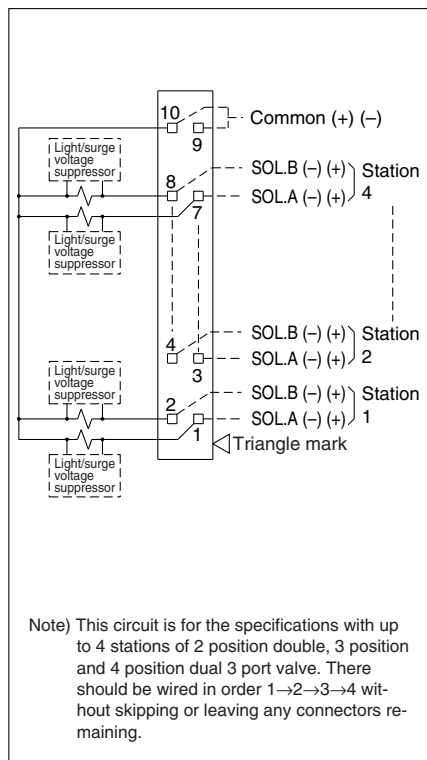

Type 60J: Flat ribbon cable (20 pins, PC wiring)

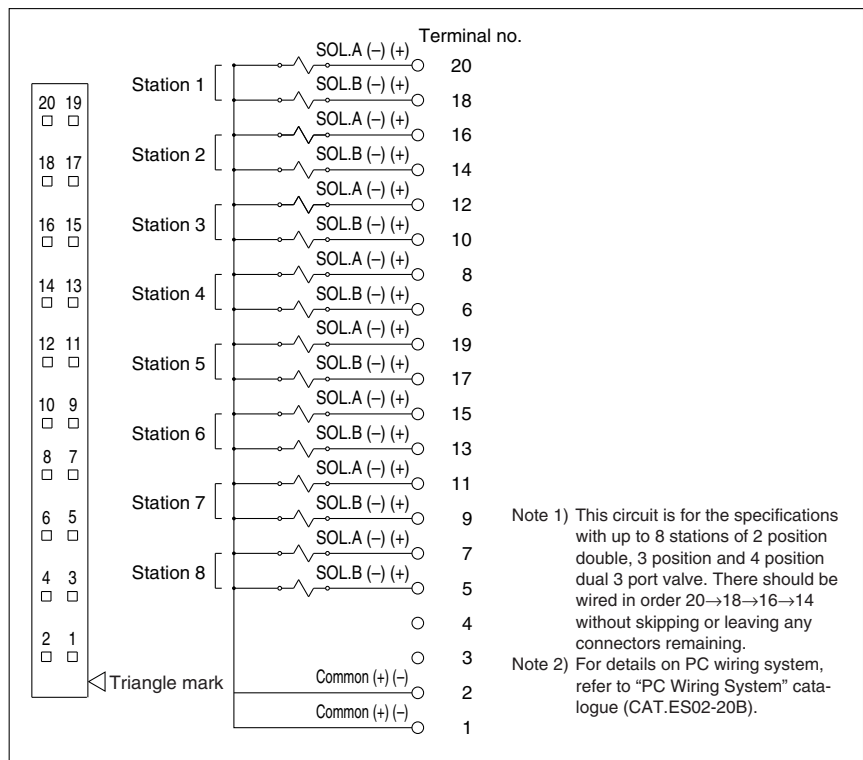

Dimensions: SJ2000 for D-sub Connector

SS5J2-60FD¹-Stations U (S, R, RS)

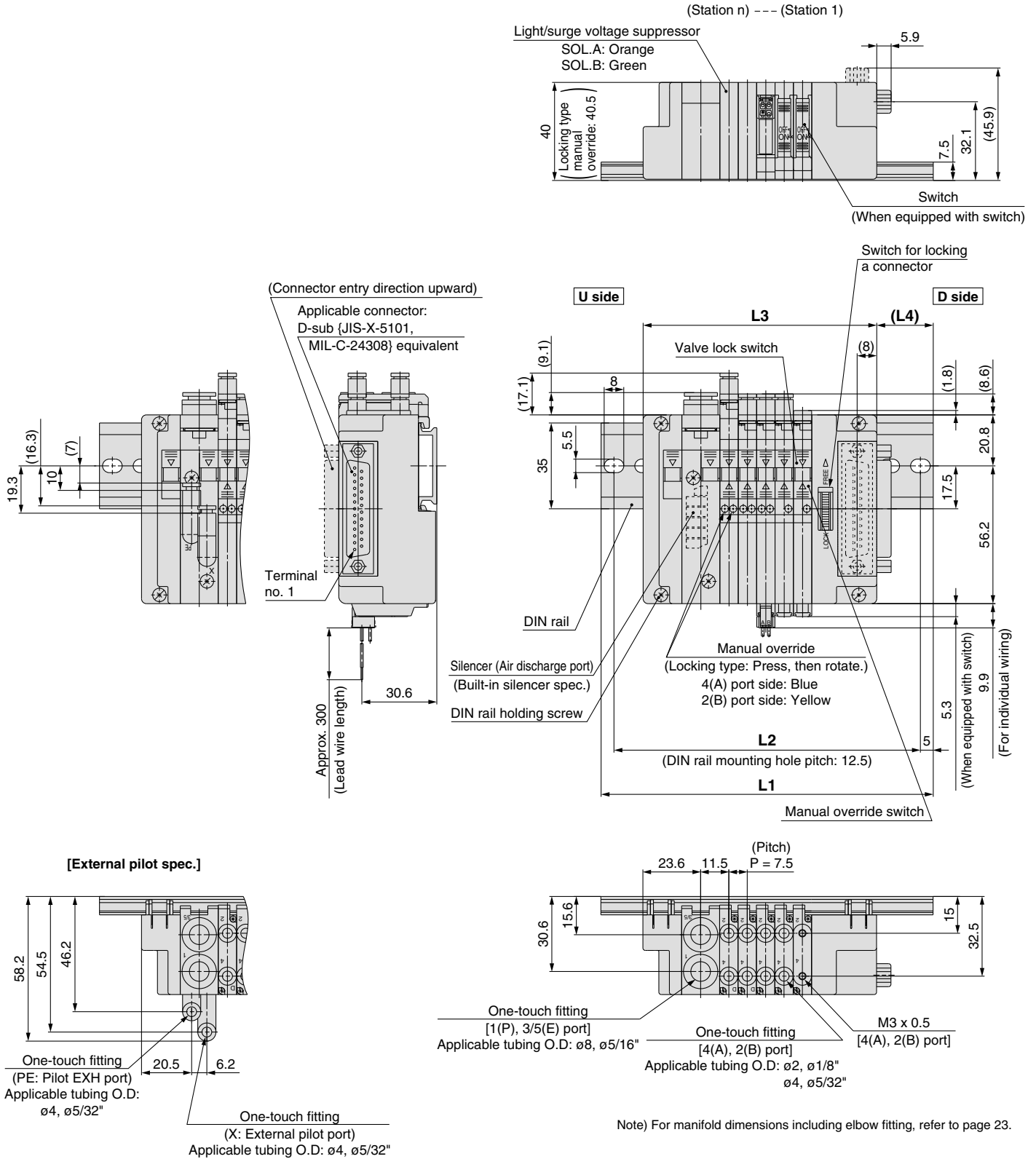

L: Dimensions

n: Stations

L \ n	2	3	4	5	6	7	8	9	10
L1	110.5	110.5	123	135.5	135.5	148	148	160.5	173
L2	100	100	112.5	125	125	137.5	137.5	150	162.5
L3	72.8	80.3	87.8	95.3	102.8	110.3	117.8	125.3	132.8
L4	22	18	20.5	23	19.5	22	18	20.5	23

Series SJ2000/3000

Dimensions: SJ2000 for D-sub Connector

SS5J2-60FD₂- Stations B (S, R, RS)

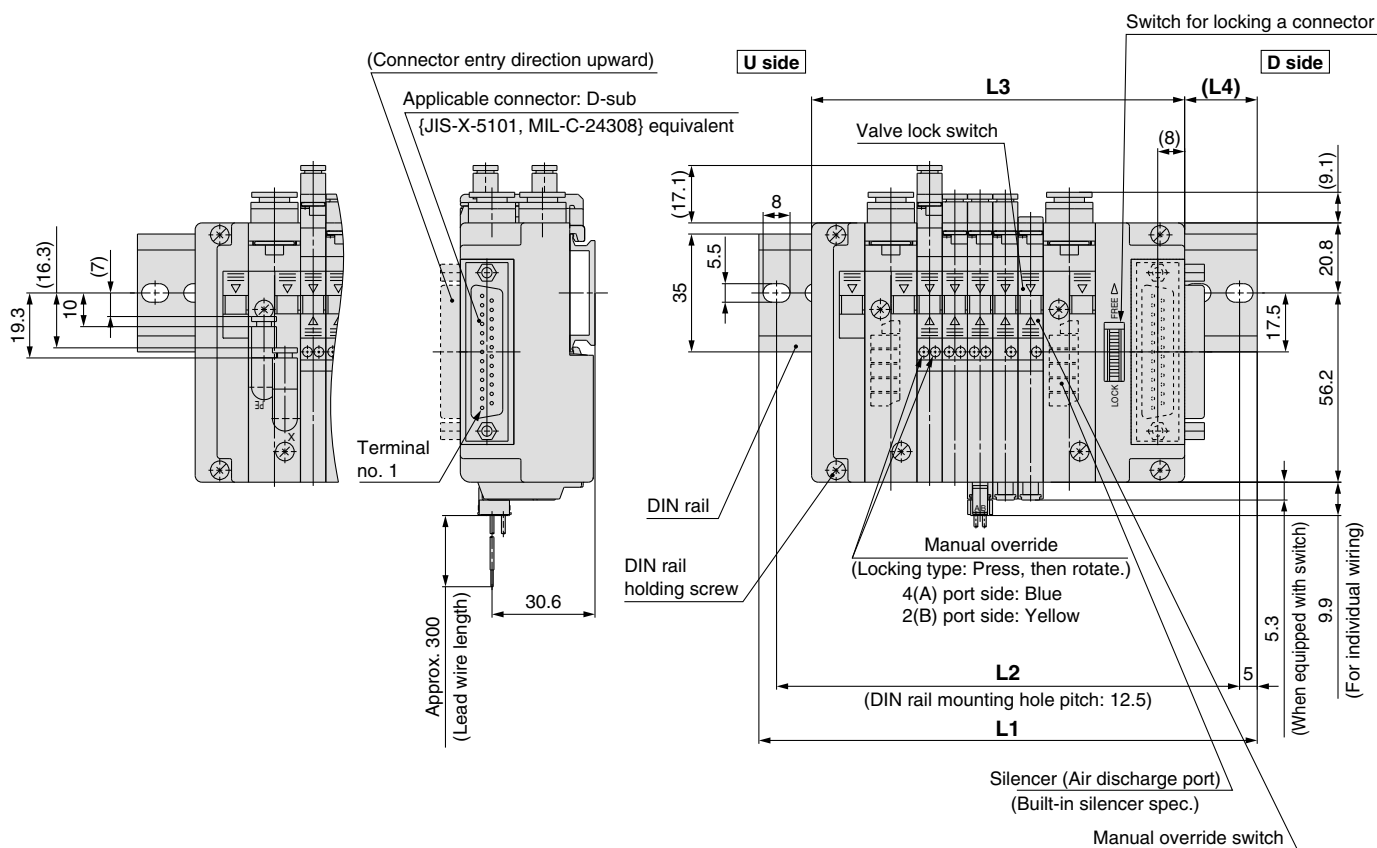
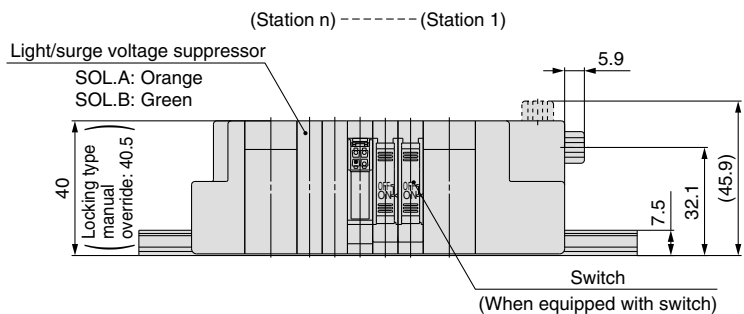

[External pilot spec.]
(There is a piping of X, PE port in the both sides.)

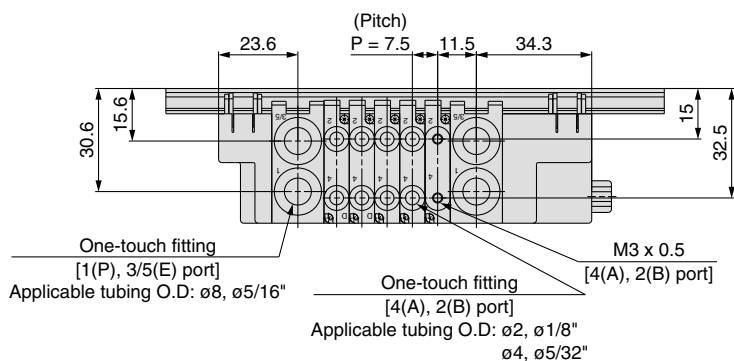
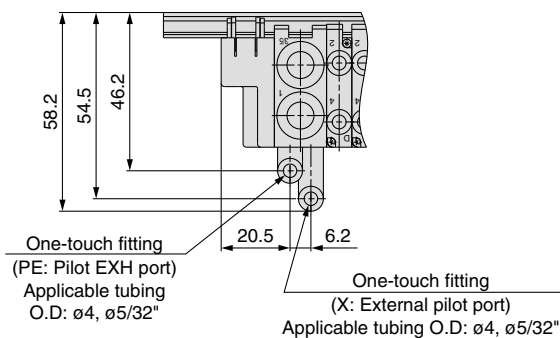

Note) For manifold dimensions including elbow fitting, refer to page 23.

L: Dimensions

n	2	3	4	5	6	7	8	9	10	11	12	13	14	15	16	17	18	19	20	21	22	23	24
L1	123	135.5	135.5	148	148	160.5	173	173	185.5	185.5	198	210.5	210.5	223	223	235.5	248	248	260.5	260.5	273	285.5	285.5
L2	112.5	125	125	137.5	137.5	150	162.5	162.5	175	175	187.5	200	200	212.5	212.5	225	237.5	237.5	250	250	262.5	275	275
L3	88.3	95.8	103.3	110.8	118.3	125.8	133.3	140.8	148.3	155.8	163.3	170.8	178.3	185.8	193.3	200.8	208.3	215.8	223.3	230.8	238.3	245.8	253.3
L4	20.5	23	19	21.5	18	20.5	23	19	21.5	18	20.5	23	19	21.5	18	20.5	23	19	21.5	18	20.5	23	19

Dimensions: SJ3000 for D-sub Connector

SS5J3-60FD₂- [Stations] U (S, R, RS)

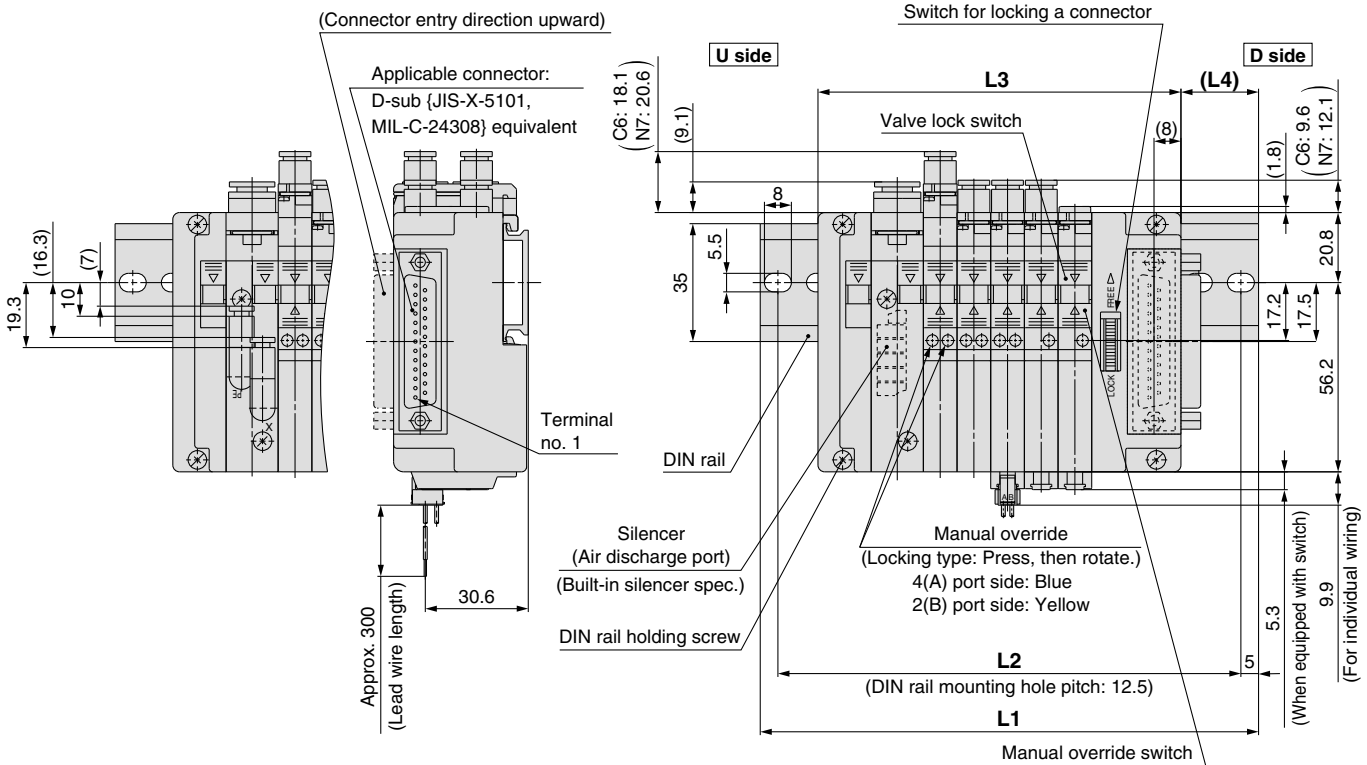
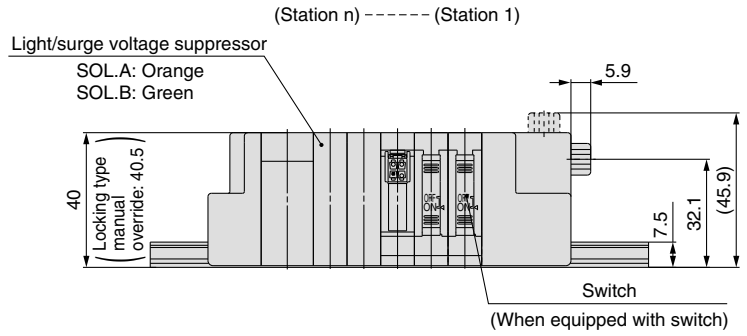

[External pilot spec.]

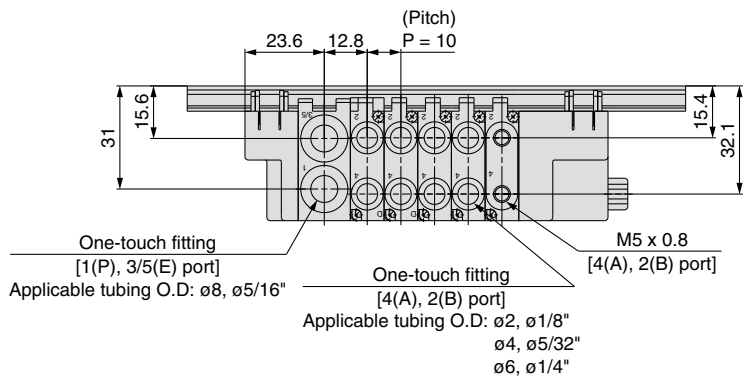
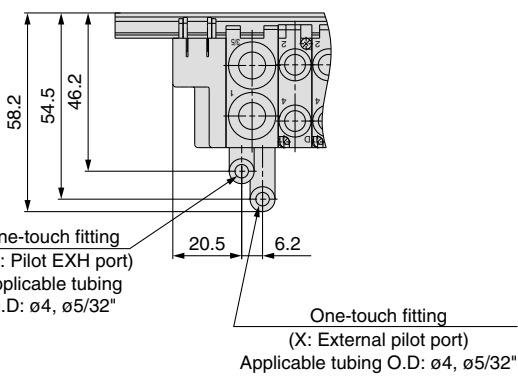

Note) For manifold dimensions including elbow fitting, refer to page 24.

L: Dimensions

n: Stations

L	n	2	3	4	5	6	7	8	9	10
L1		110.5	123	135.5	148	148	160.5	173	185.5	198
L2		100	112.5	125	137.5	137.5	150	162.5	175	187.5
L3		77.8	87.8	97.8	107.8	117.8	127.8	137.8	147.8	157.8
L4		19	20.5	21.5	22.5	17.5	18.5	20	21	22

Series SJ2000/3000

Dimensions: SJ3000 for D-sub Connector

SS5J3-60FD₂- Stations B (S, R, RS)

(Station n) ----- (Station 1)

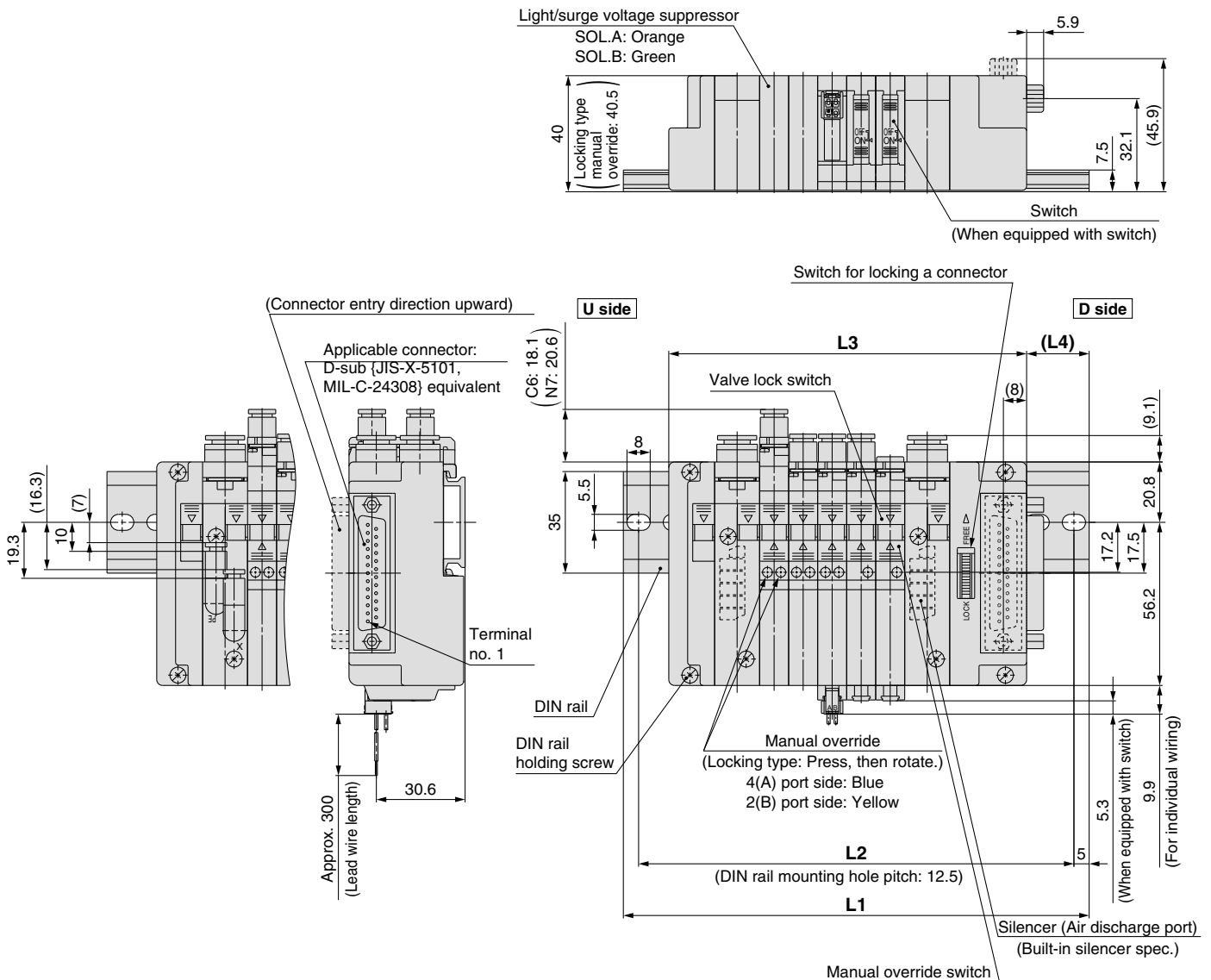

[External pilot spec.]

(There is a piping of X, PE port in the both sides.)

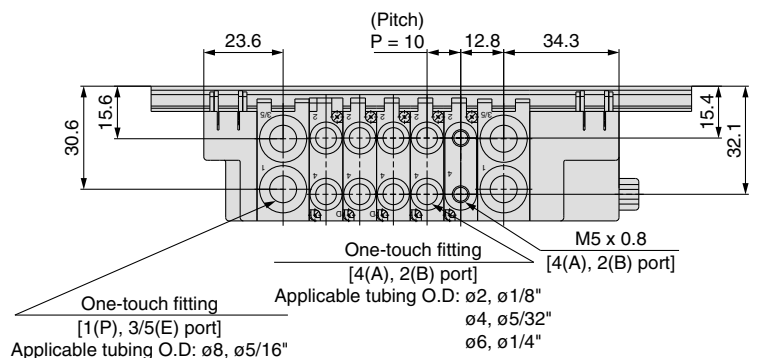
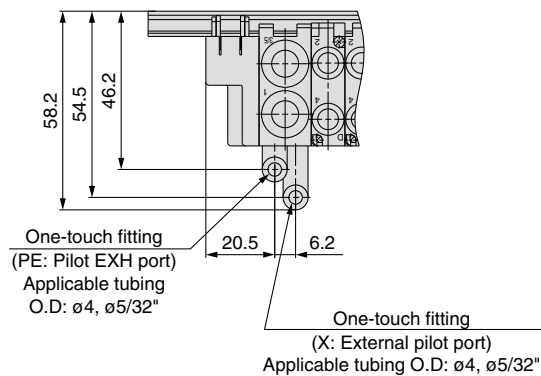

Note) For manifold dimensions including elbow fitting, refer to page 24.

L: Dimensions

n: Stations

L	n	2	3	4	5	6	7	8	9	10	11	12	13	14	15	16	17	18	19	20	21	22	23	24
L1		123	135.5	148	160.5	173	185.5	185.5	198	210.5	223	235.5	235.5	248	260.5	273	285.5	298	298	310.5	323	335.5	348	348
L2		112.5	125	137.5	150	162.5	175	175	187.5	200	212.5	225	225	237.5	250	262.5	275	287.5	287.5	300	312.5	325	337.5	337.5
L3		93.3	103.3	113.3	123.3	133.3	143.3	153.3	163.3	173.3	183.3	193.3	203.3	213.3	223.3	233.3	243.3	253.3	263.3	273.3	283.3	293.3	303.3	313.3
L4		17.5	19	20	21	22	23.5	18.5	19.5	20.5	21.5	23	18	19	20	21	22.5	23.5	18.5	19.5	20.5	22	23	18

Dimensions: SJ2000/3000 Mixed Manifold

SS5J3-M60FD₂-[Stations] U (S, R, RS)

Applicable connector: D-sub (JIS-X-5101, MIL-C-24308) equivalent

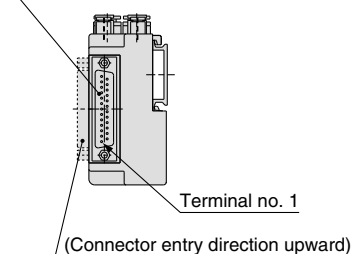

L dimension: Formula, L1 to L4
 $L3 = 7.5 \times n1 + 10 \times n2 + 57.8$
 $M = (L3 + 9.9)/12.5 + 1$
 Remove all numbers after the decimal.
 $L1 = M \times 12.5 + 23$
 $L2 = L1 - 10.5$
 $L4 = (L1 - L3)/2 + 1$

n1: Piece of the SJ2000
 n2: Piece of the SJ3000

Note) The dimensions of L1 to L4 for **SS5J3-M60FD1/2-[Stations]D** are the same as those of **SS5J3-M60FD1/2-[Stations]U**.

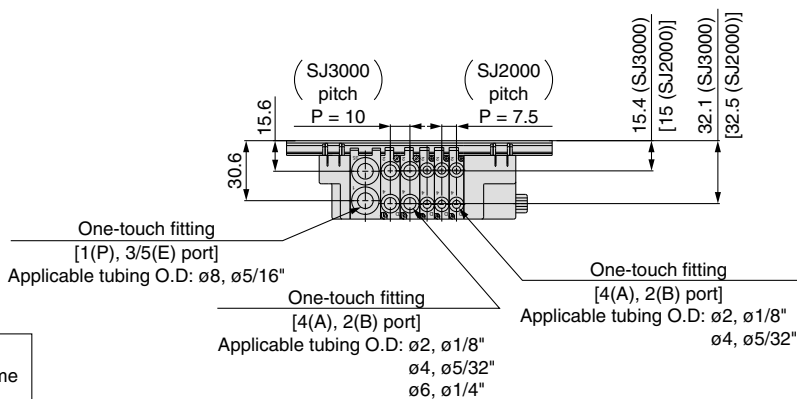
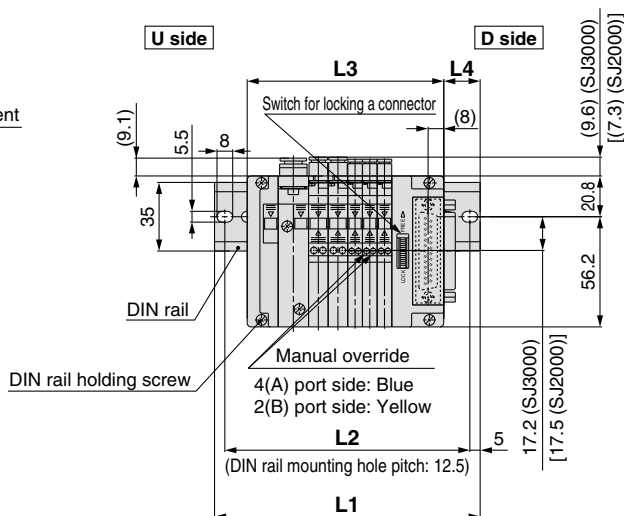

SS5J3-M60FD₂-[Stations] B (S, R, RS)

Applicable connector: D-sub (JIS-X-5101, MIL-C-24308) equivalent

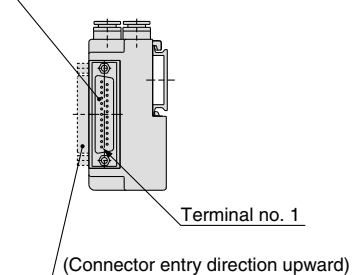

L dimension: Formula, L1 to L4
 $L3 = 7.5 \times n1 + 10 \times n2 + 73.3$
 $M = (L3 + 9.9)/12.5 + 1$
 Remove all numbers after the decimal.
 $L1 = M \times 12.5 + 23$
 $L2 = L1 - 10.5$
 $L4 = (L1 - L3)/2 + 1$

n1: Piece of the SJ2000
 n2: Piece of the SJ3000

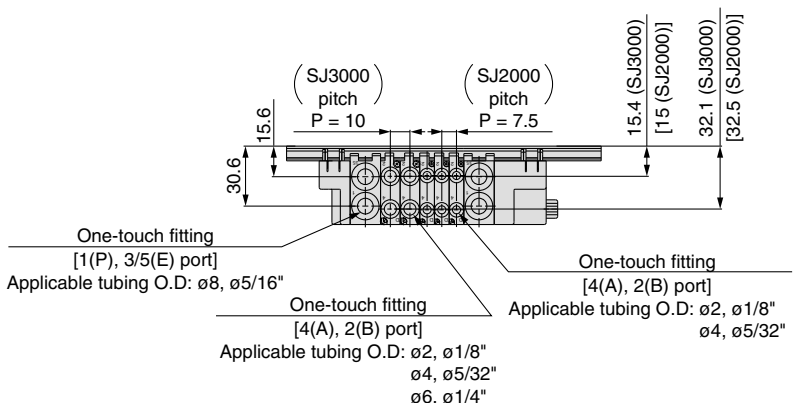
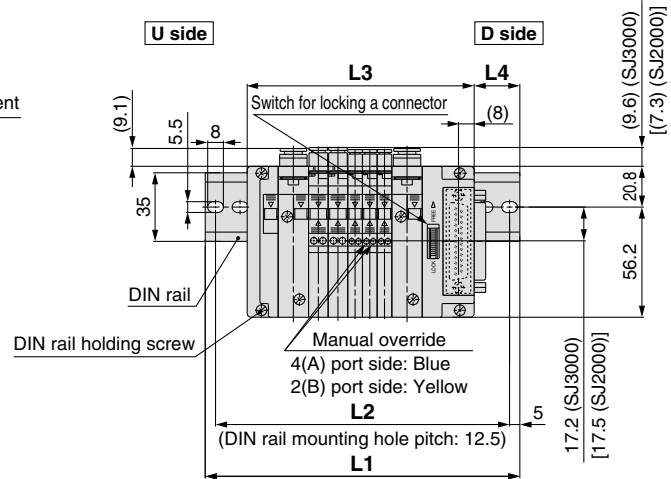

Series SJ2000/3000

Dimensions: SJ2000 for Flat Ribbon Cable / PC Wiring

SS5J2-60^PD₂- Stations U (S, R, RS)

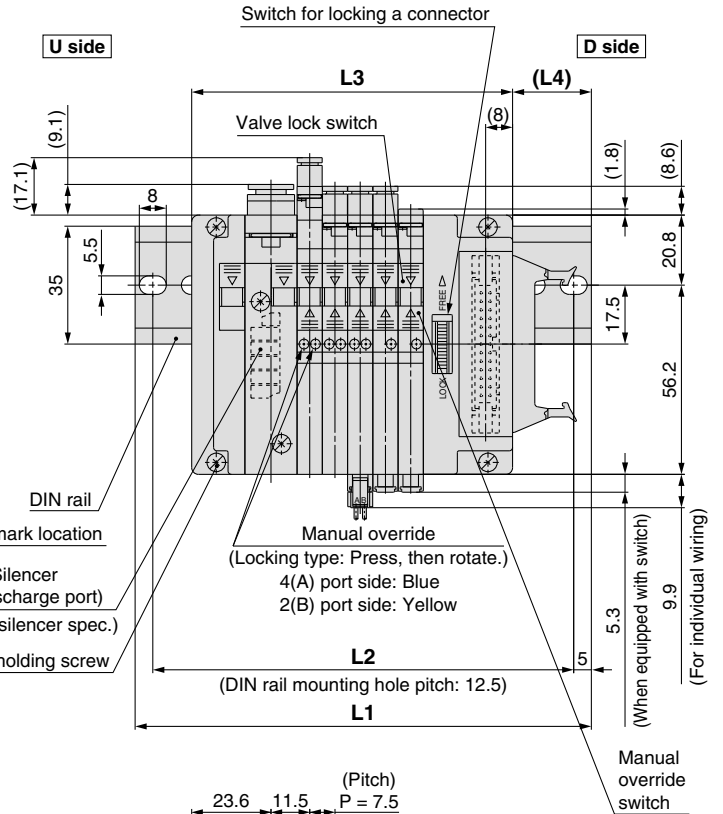
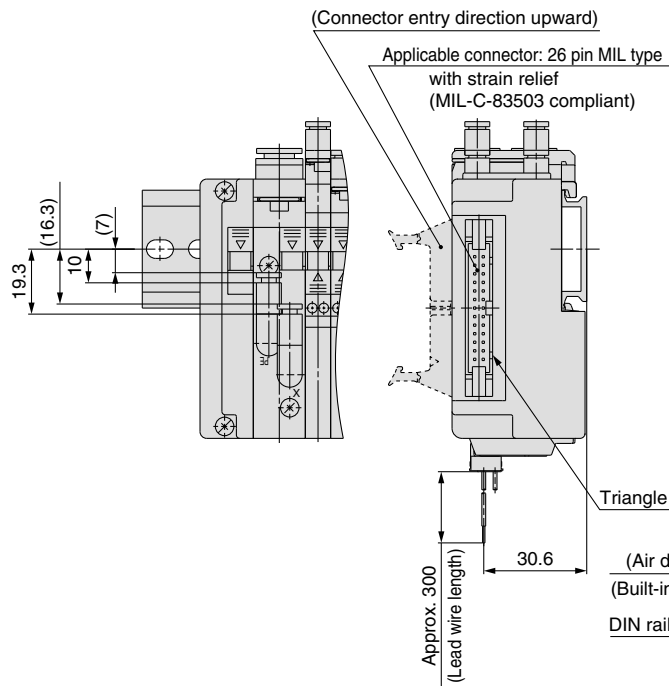
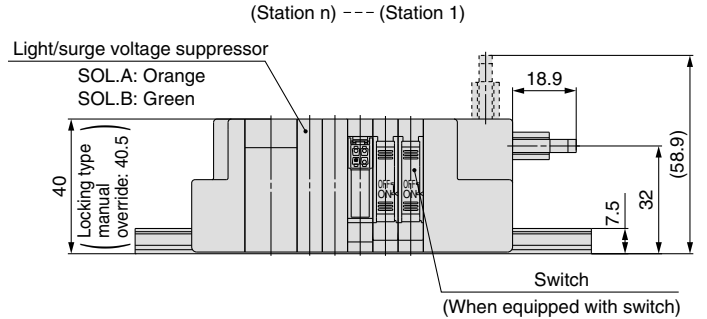
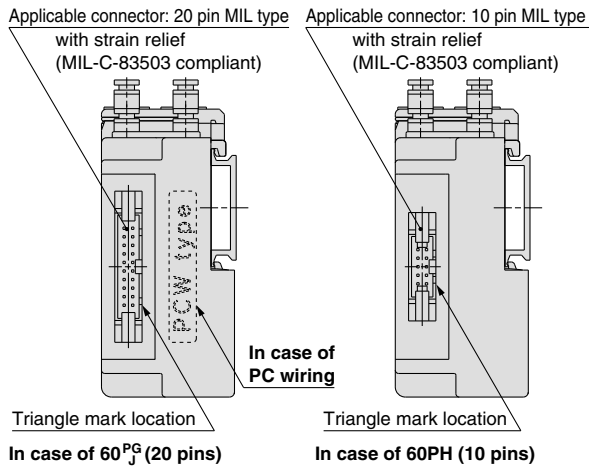

[External pilot spec.]

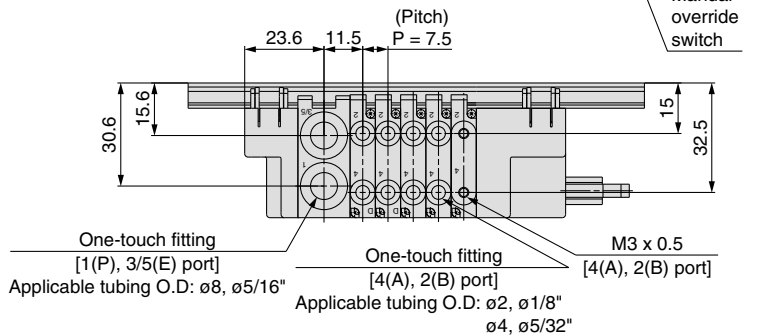
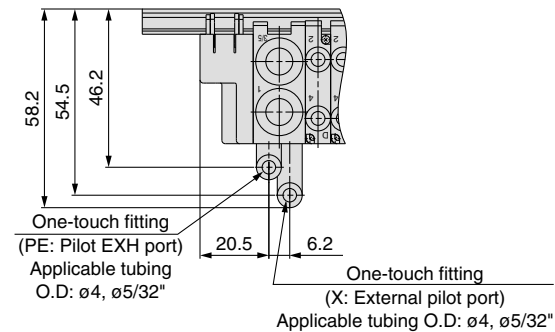

L: Dimensions

n: Stations

L \ n	2	3	4	5	6	7	8	9	10
L1	110.5	110.5	123	135.5	135.5	148	148	160.5	173
L2	100	100	112.5	125	125	137.5	137.5	150	162.5
L3	72.8	80.3	87.8	95.3	102.8	110.3	117.8	125.3	132.8
L4	22	18.5	21	23.5	19.5	22	18.5	21	23.5

Note 1) Type 60PG, 60PH and 60J differ only in their connectors, and the L1 through L4 dimensions are the same as type 60P.

Note 2) For manifold dimensions including elbow fitting, refer to page 23.

Dimensions: SJ2000 for Flat Ribbon Cable / PC Wiring

SS5J2-60^PD₂- Stations B (S, R, RS)

Applicable connector: 20 pin MIL type with strain relief (MIL-C-83503 compliant)
 Applicable connector: 10 pin MIL type with strain relief (MIL-C-83503 compliant)

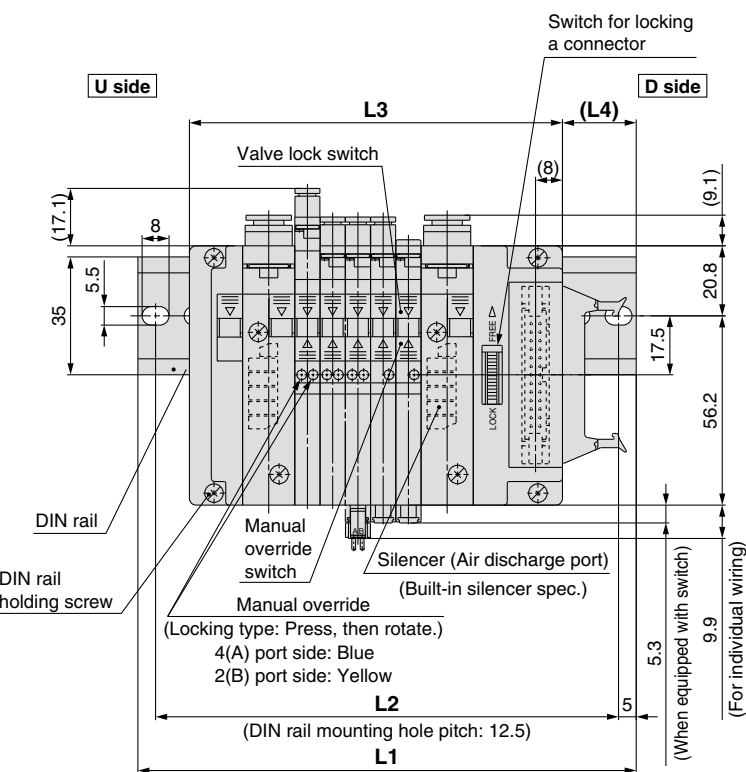
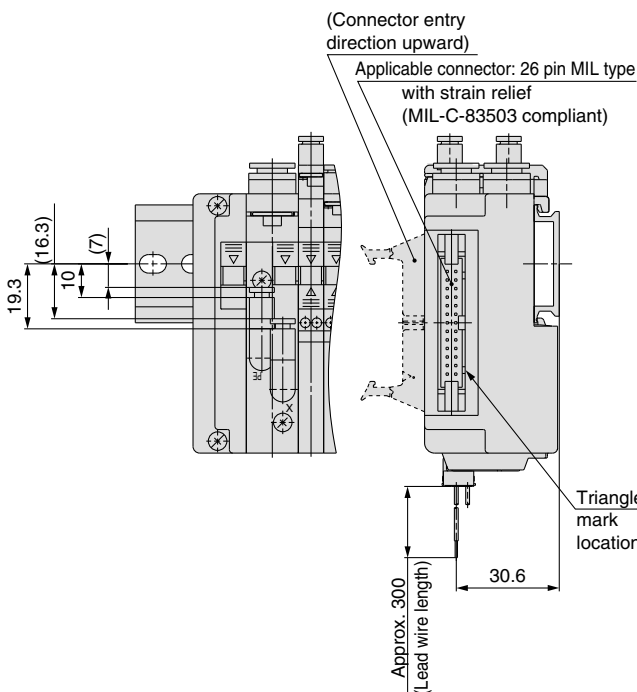
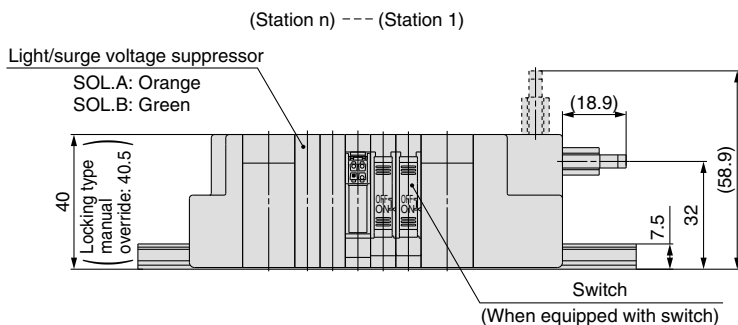
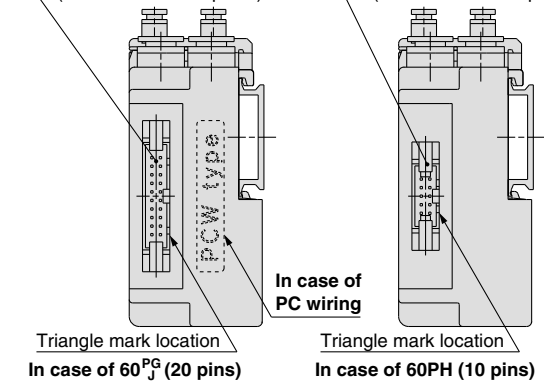

[External pilot spec.]
 (There is a piping of X, PE port in the both sides.)

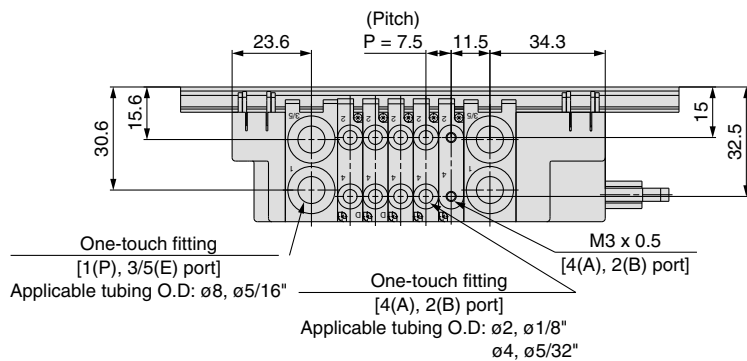
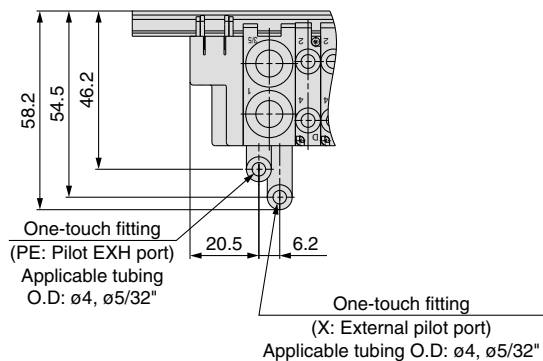

Note 1) Type 60PG, 60PH and 60J differ only in their connectors, and the L1 through L4 dimensions are the same as type 60P.
 Note 2) For manifold dimensions including elbow fitting, refer to page 23.

L: Dimensions

L	n: Stations																							
	2	3	4	5	6	7	8	9	10	11	12	13	14	15	16	17	18	19	20	21	22	23	24	
L1	123	135.5	135.5	148	148	160.5	173	173	185.5	185.5	198	210.5	210.5	223	223	235.5	248	248	260.5	260.5	273	285.5	285.5	
L2	112.5	125	125	137.5	137.5	150	162.5	162.5	175	175	187.5	200	200	212.5	212.5	225	237.5	237.5	250	250	262.5	275	275	
L3	88.3	95.8	103.3	110.8	118.3	125.8	133.3	140.8	148.3	155.8	163.3	170.8	178.3	185.8	193.3	200.8	208.3	215.8	223.3	230.8	238.3	245.8	253.3	
L4	20.5	23	19.5	22	18	20.5	23	19.5	22	18	20.5	23	19.5	22	18	20.5	23	19.5	22	18	20.5	23	19.5	

Series SJ2000/3000

Dimensions: SJ3000 for Flat Ribbon Cable / PC Wiring

SS5J3-60^PD₂- Stations U (S, R, RS)

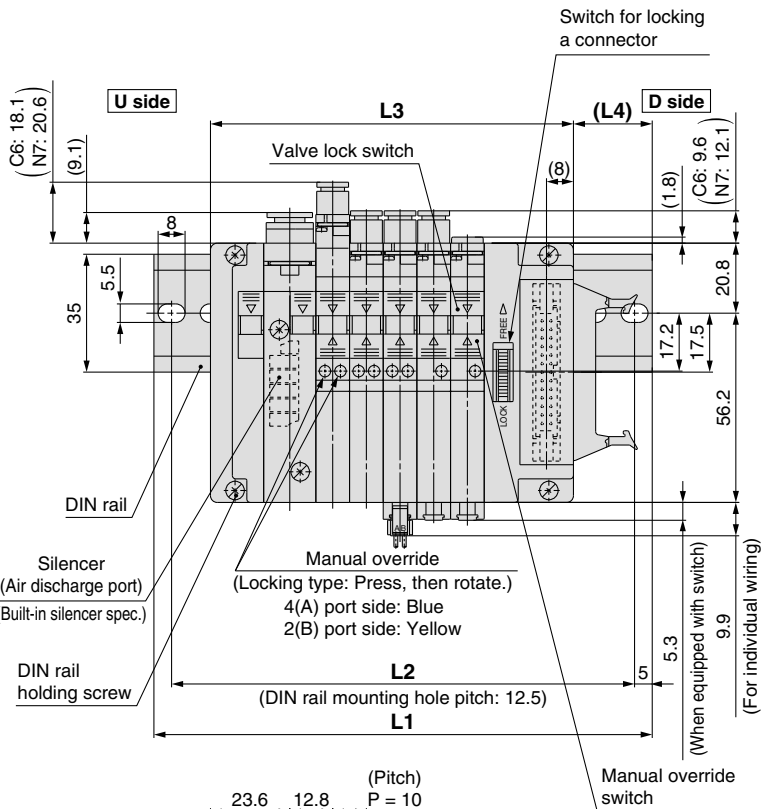
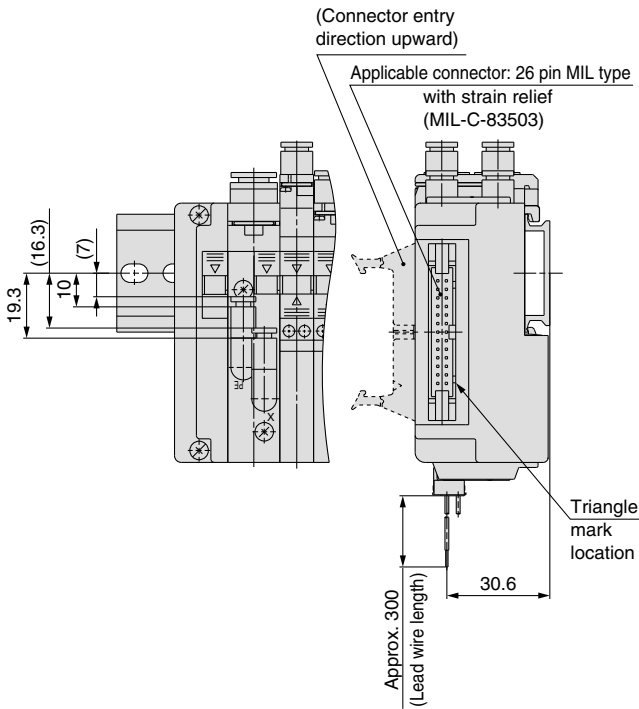
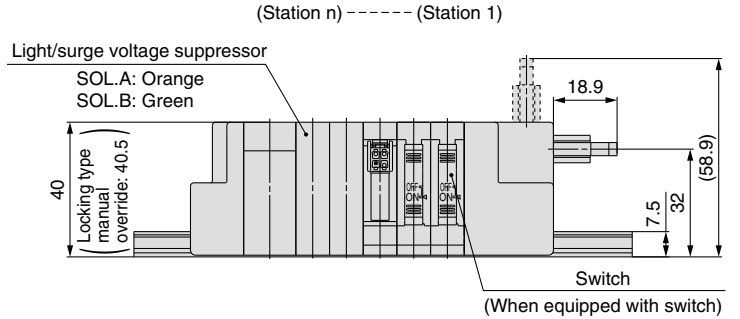
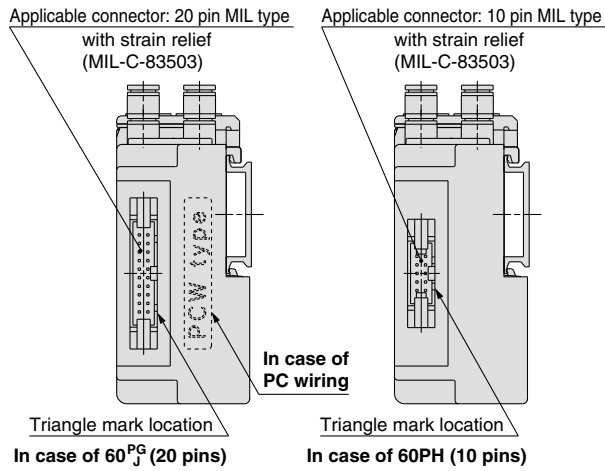

[External pilot spec.]

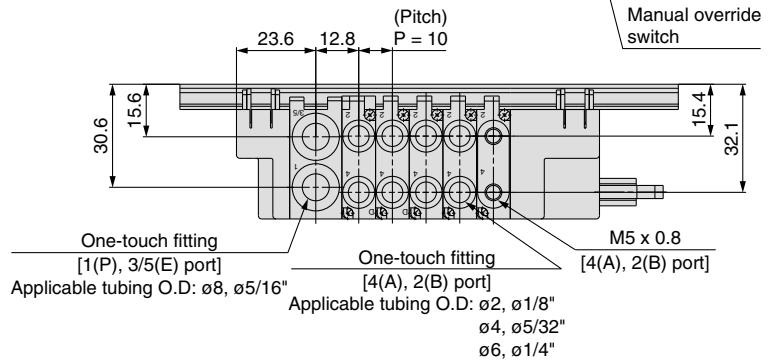
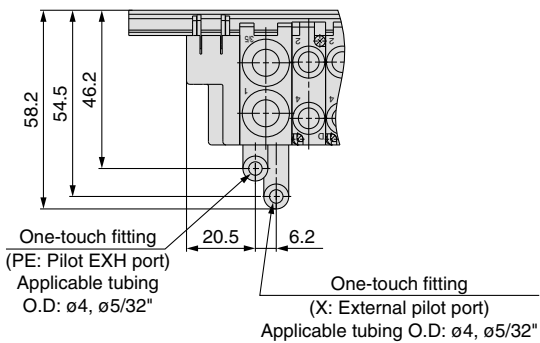

L: Dimensions

n: Stations

L \ n	2	3	4	5	6	7	8	9	10
L1	110.5	123	135.5	148	160.5	160.5	173	185.5	198
L2	100	112.5	125	137.5	150	150	162.5	175	187.5
L3	77.8	87.8	97.8	107.8	117.8	127.8	137.8	147.8	157.8
L4	19.5	20.5	22	23	24	19	20	21.5	22.5

Note 1) Type 60PG, 60PH and 60J differ only in their connectors, and the L1 through L4 dimensions are the same as type 60P.

Note 2) For manifold dimensions including elbow fitting, refer to page 24.

Dimensions: SJ3000 for Flat Ribbon Cable / PC Wiring

SS5J3-60^PD₂- Stations B (S, R, RS)

Applicable connector: 20 pin MIL type with strain relief (MIL-C-83503 compliant)
 Applicable connector: 10 pin MIL type with strain relief (MIL-C-83503 compliant)

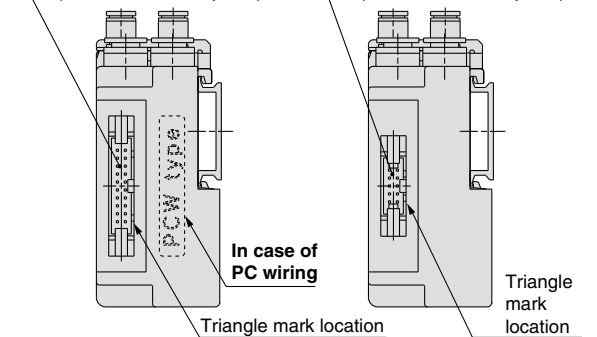

In case of 60^{PG} (20 pins) In case of 60PH (10 pins)

(Connector entry direction upward)
 Applicable connector: 26 pin MIL type with strain relief (MIL-C-83503 compliant)

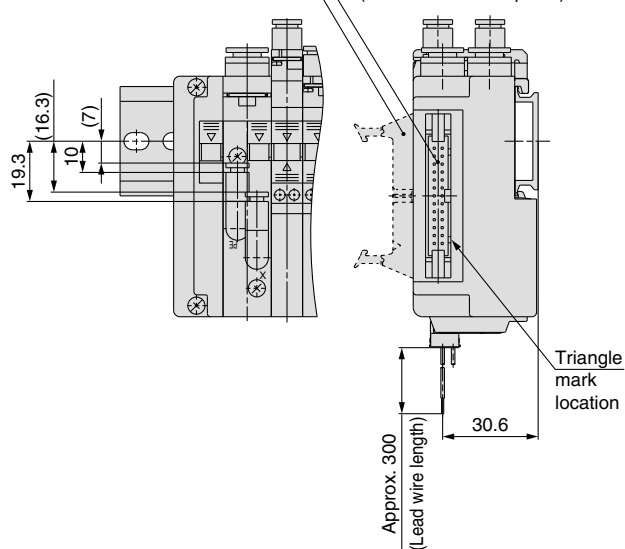

[External pilot spec.]
 (There is a piping of X, PE port in the both sides.)

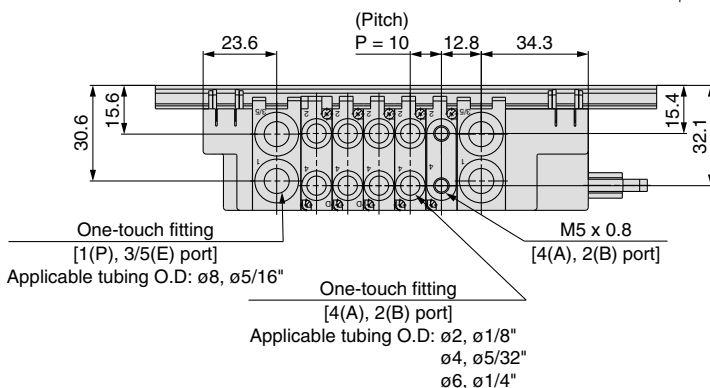
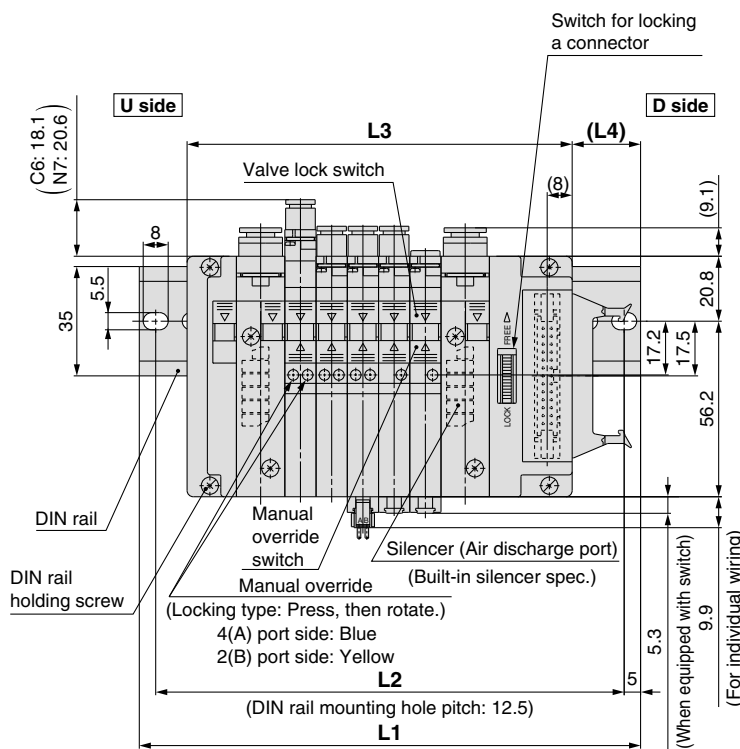
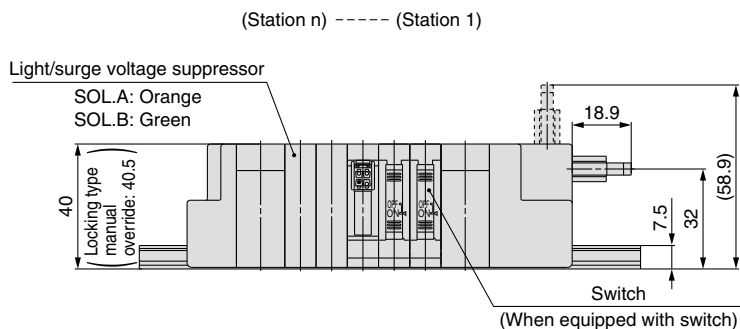
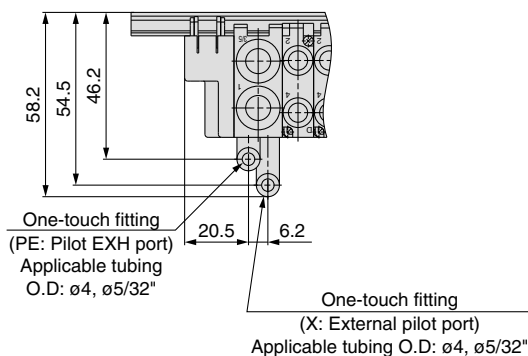

Note 1) Type 60PG, 60PH and 60J differ only in their connectors, and the L1 through L4 dimensions are the same as type 60P.

Note 2) For manifold dimensions including elbow fitting, refer to page 24.

L: Dimensions

L \ n	n: Stations																							
	2	3	4	5	6	7	8	9	10	11	12	13	14	15	16	17	18	19	20	21	22	23	24	
L1	135.5	135.5	148	160.5	173	185.5	185.5	198	210.5	223	235.5	248	248	260.5	273	285.5	298	298	310.5	323	335.5	348	348	
L2	125	125	137.5	150	162.5	175	175	187.5	200	212.5	225	237.5	237.5	250	262.5	275	287.5	287.5	300	312.5	325	337.5	337.5	
L3	93.3	103.3	113.3	123.3	133.3	143.3	153.3	163.3	173.3	183.3	193.3	203.3	213.3	223.3	233.3	243.3	253.3	263.3	273.3	283.3	293.3	303.3	313.3	
L4	24	19	20.5	21.5	22.5	23.5	18.5	20	21	22	23	24.5	19.5	20.5	21.5	22.5	24	19	20	21	22	23.5	18.5	

Series SJ2000/3000

Dimensions: SJ2000/3000 Mixed Manifold

SS5J3-M60_JD₂- [Stations] U (S, R, RS)

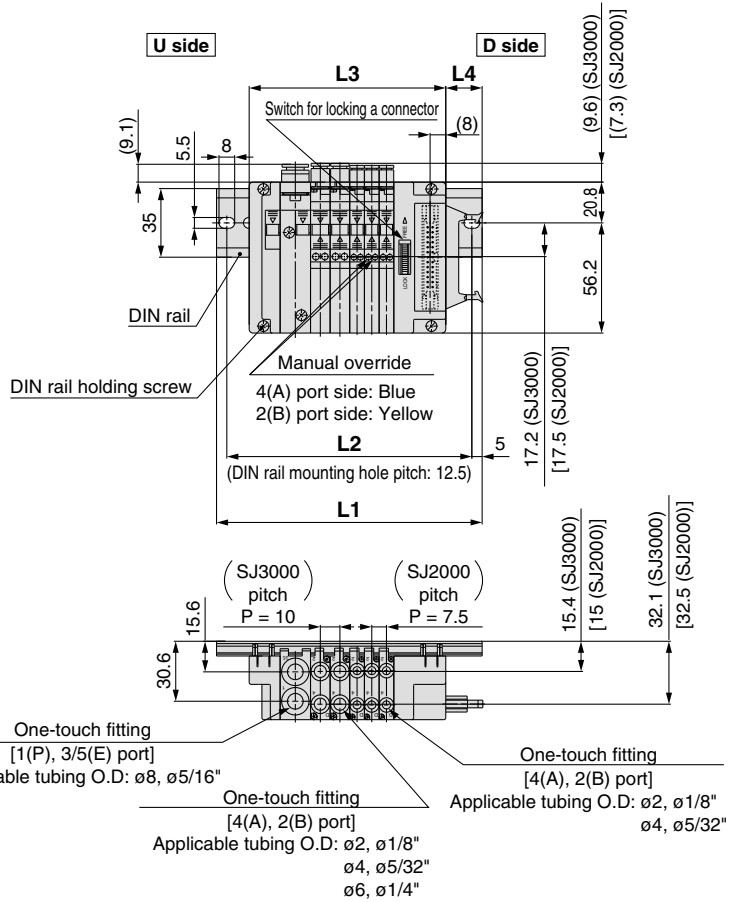
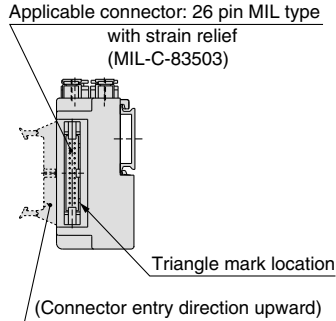

L dimension: Formula, L1 to L4
 $L3 = 7.5 \times n1 + 10 \times n2 + 57.8$
 $M = (L3 + 10.6) / 12.5 + 1$
 Remove all numbers after the decimal.
 $L1 = M \times 12.5 + 23$
 $L2 = L1 - 10.5$
 $L4 = (L1 - L3) / 2 + 1.3$

n1: Piece of the SJ2000
 n2: Piece of the SJ3000

Note) The dimensions of L1 to L4 for SS5J3-M60PD1/2-[Stations]D are the same as those of SS5J3-M60PD1/2-[Stations]U.

SS5J3-M60_JD₂- [Stations] B (S, R, RS)

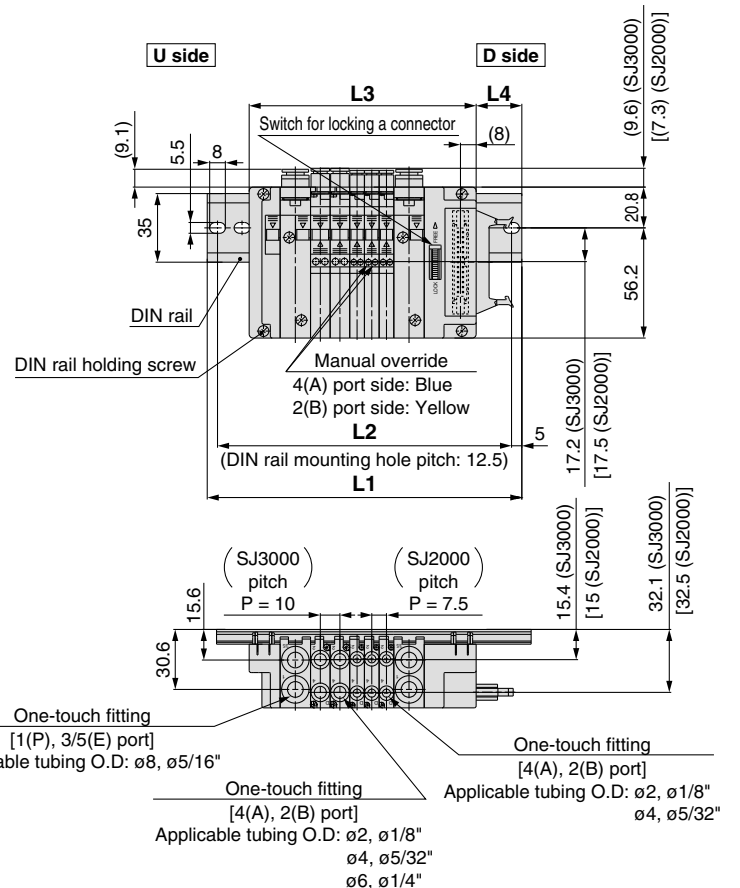
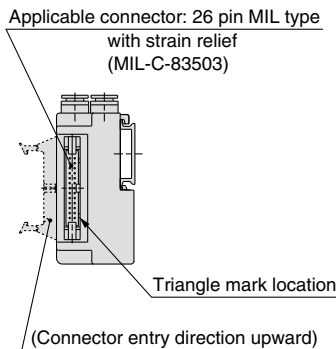

L dimension: Formula, L1 to L4
 $L3 = 7.5 \times n1 + 10 \times n2 + 73.3$
 $M = (L3 + 10.6) / 12.5 + 1$
 Remove all numbers after the decimal.
 $L1 = M \times 12.5 + 23$
 $L2 = L1 - 10.5$
 $L4 = (L1 - L3) / 2 + 1.3$

n1: Piece of the SJ2000
 n2: Piece of the SJ3000

Dimensions: SJ2000 with Elbow Fittings

SS5J2-60FD₂- Stations U_B

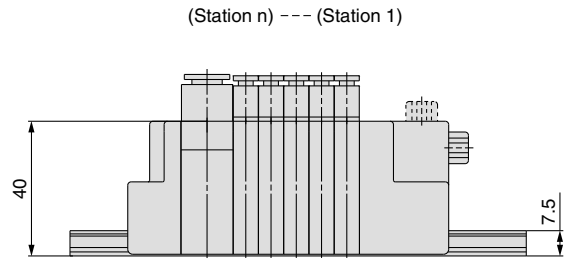
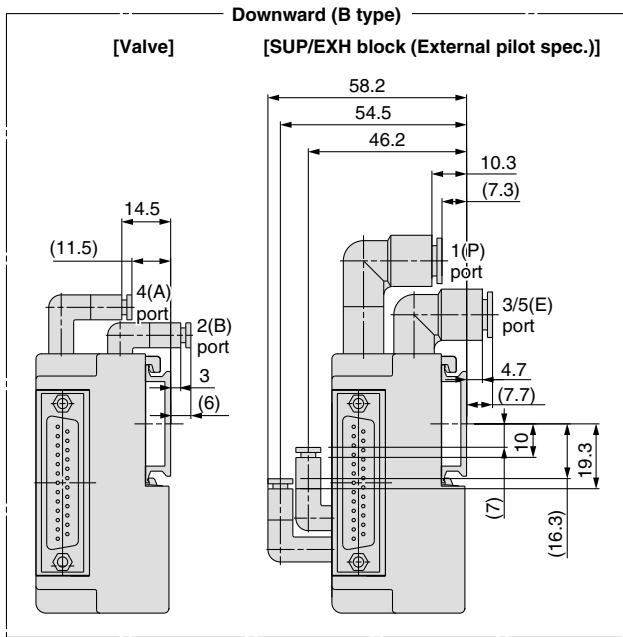

U side One-touch fitting [1(P), 3/5(E) port]
 Applicable tubing O.D: ø8

D side One-touch fitting [2(B), 4(A) port]
 Applicable tubing O.D: ø2, ø1/8", ø4, ø5/32"

Note) Inch sizes for elbow fittings are not available.

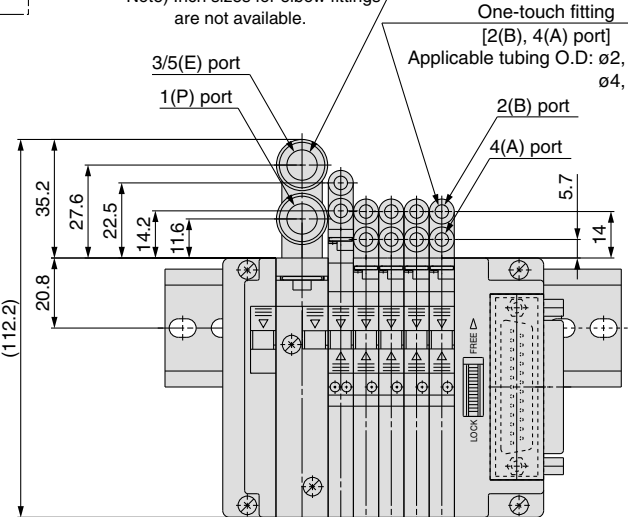

[SUP/EXH block (External pilot spec.)]

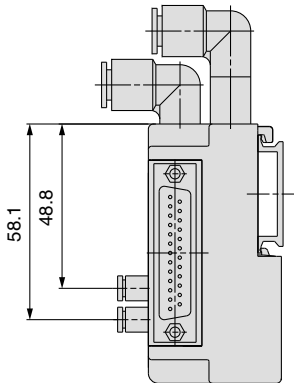

[External pilot spec.]

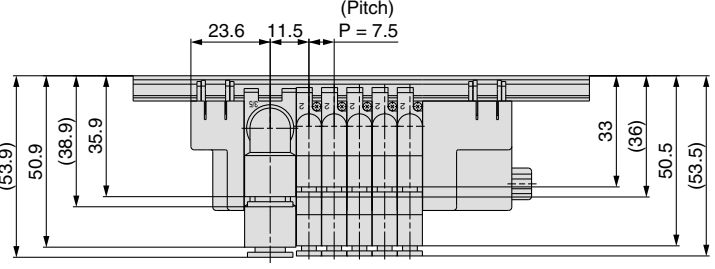
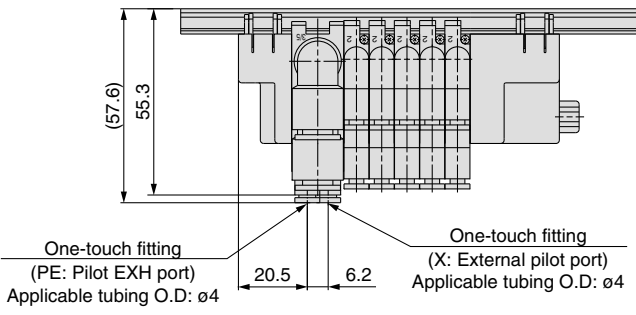

Series SJ2000/3000

Dimensions: SJ3000 with Elbow Fittings

SS5J3-60FD₂- Stations U_B

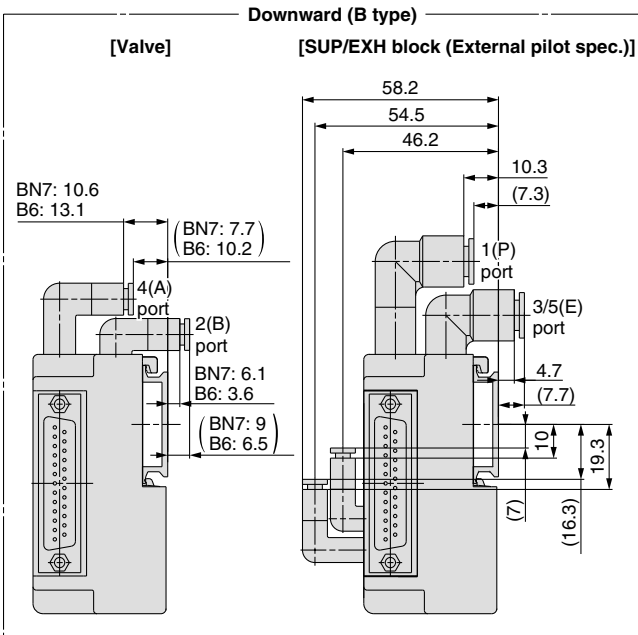

[SUP/EXH block (External pilot spec.)]

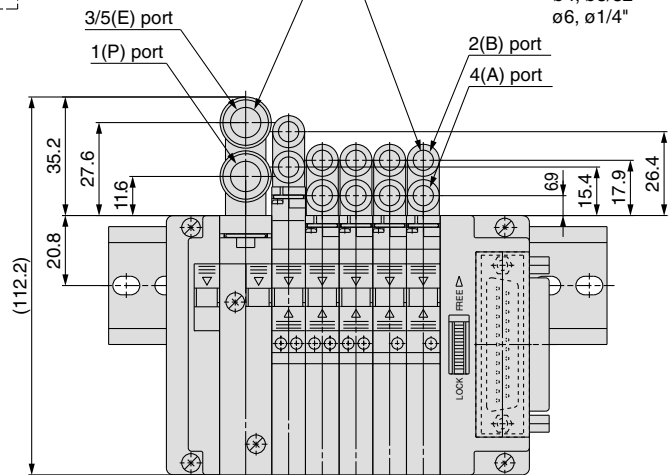
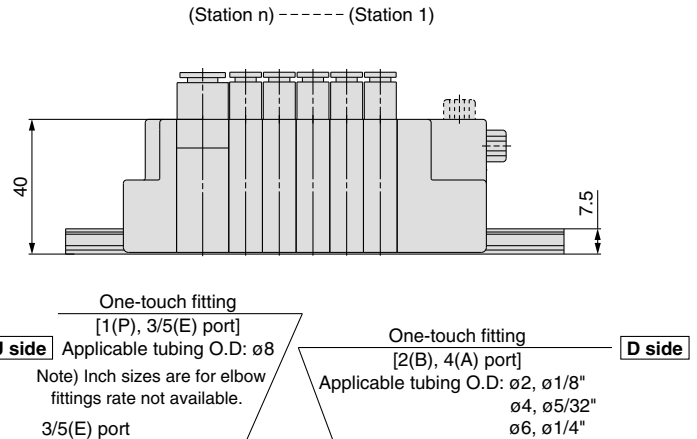
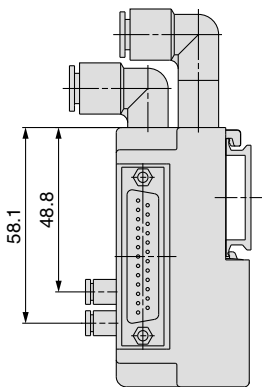

[External pilot spec.]

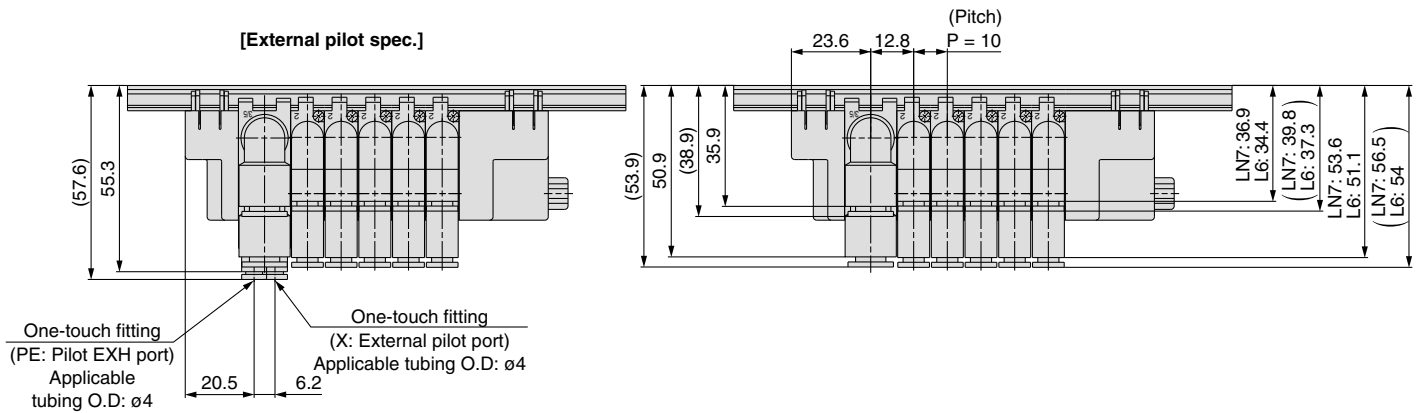

Plug-in Connector Type PC Wiring System with Power Supply Terminal Series **SJ2000/3000**

How to Order

● Connector type manifold

SS5J **3** - **60GD** - **05U** **□** **□** **□**

Series

2	SJ2000
3	SJ3000 (SJ2000/3000 mixed)

Mixed mounting type

—	Standard (Note 1)
M	Mixed mounting (Note 2)

Note 1) There is no need to enter anything when you order either the SJ2000 or SJ3000 series alone.

Note 2) Enter "M" when the SJ2000 or SJ3000 series will be mounted on the same manifold base together.

Connector type

Flat ribbon cable (20 pins)

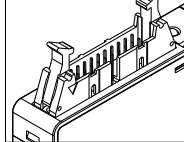

Connector mounting position

Symbol	Mounting position
D	D side

● DIN rail length specified

—	Standard length	
3	3 stations	Specify a longer rail than the standard length.
⋮	⋮	
16	16 stations	

* Specify the valve stations not exceeding the maximum stations.

● SUP/EXH block fitting spec.

—	Straight fitting With external pilot spec. X, PE port	
L	Elbow fitting (upward) With external pilot spec. X, PE port	
B	Elbow fitting (downward) With external pilot spec. X, PE port	

Note) here is no need to enter anything when the SUP/EXH block mounting position "M" is selected.

● Pilot spec.

—	Internal pilot
S	Internal pilot / Built-in silencer
R	External pilot
RS	External pilot / Built-in silencer

Note 1) There is no need to enter anything when the SUP/EXH block mounting position "M" is selected.

Note 2) For built-in silencers, the 3/5(E) ports are plugged.

● SUP/EXH block mounting position

U	U side (2 to 10 stations)
D	D side (2 to 10 stations)
B	Both sides (2 to 16 stations)
M*	Special specifications

Note) Specify the required specifications (including port sizes other than ø8) by means of the manifold specification sheet.

● Valve stations

Symbol	Stations	Note
02	2 stations	Up to 16 solenoids possible.
⋮	⋮	
16	16 stations	

Note) The number of the blanking block assembly is also included. Since single and double wiring are available with the blanking block assembly, select a model compatible with the valve wiring spec. planned for the future. (Refer to page 61.)

How to Order Valve Manifold Assembly

Ordering example (SJ3000)

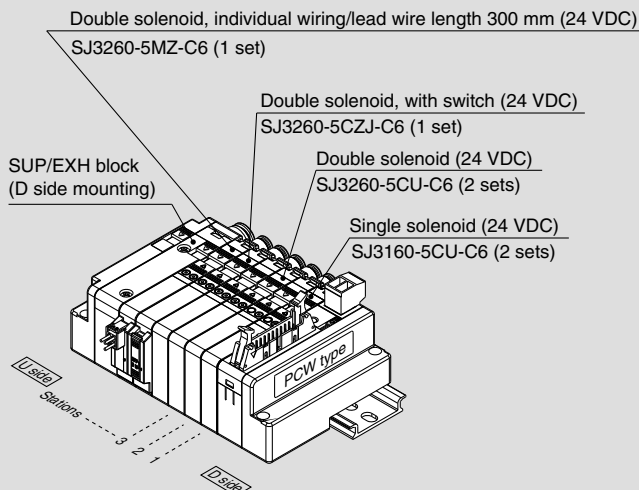

SS5J3-60GD-06U 1 set (Manifold part no.)
 * **SJ3160-5CU-C6** 2 sets (Single solenoid part no.)
 * **SJ3260-5CU-C6** 2 sets (Double solenoid part no.)
 * **SJ3260-5CZJ-C6** 1 set (Double solenoid, with switch part no.)
 * **SJ3260-5MZ-C6** 1 set (Double solenoid, individual wiring/lead wire length 300 mm part no.)

— The asterisk denotes the symbol for assembly.
 Prefix to the part no. of the solenoid valve, etc.

- The valve arrangement is numbered as the 1st station from D side.
- Indicate the valves to be attached below the manifold part number, in order starting from station 1 as shown in the drawing.
- In the case of complex arrangement, specify them in the manifold specification sheet.



For the wiring to power supply terminal, refer to back page 9.

How to Order Solenoid Valves

Standard

With switch

Individual wiring
[for plug-in mixed mounting] (Note)

Note) Refer to pages 52 and 53 for the dedicated non-plug-in individual wiring.

Type of actuation

1	2 position single solenoid
2	2 position double solenoid
3	3 position closed centre
4	3 position exhaust centre
5	3 position pressure centre
A	Dual 3 port valve: N.C./N.C.
B	Dual 3 port valve: N.O./N.O.
C	Dual 3 port valve: N.C./N.O.

Note) Refer to pages 4 through to 7 for the JIS symbol.

Series

2	SJ2000
3	SJ3000

Pilot spec.

—	Internal pilot
R	External pilot

Note) External pilot spec. is not applicable for 4 position dual 3 port valves.

Coil spec.

—	Standard
T	With power saving circuit (Continuous duty type)

Note) Be sure to select "with power saving circuit" when the solenoid valve will be energised continuously for long period.

Back pressure check valve

—	None
K	Built-in

Note) Back pressure check valve is not applicable for 3 position valve.

Rated voltage

5	24 VDC
---	--------

Single solenoid wiring spec.

—	Single wiring
D	Double wiring

Note) There is no need to enter anything for 2 position double, 3 position and 4 position solenoid valves. Select this when the unused numbers to wiring are set. Refer to page 3 for details.

A, B port size

Straight (Metric size)

C2: ø2 one-touch fitting
C4: ø4 one-touch fitting
C6: ø6 one-touch fitting (SJ3000 only)

(Inch size)

N1: ø1/8" one-touch fitting
N3: ø5/32" one-touch fitting
N7: ø1/4" one-touch fitting (SJ3000 only)

(Thread piping)

M3: M3 x 0.5 (SJ2000 only)
M5: M5 x 0.8 (SJ3000 only)

Elbow fitting assembly (dpward entry)
(Metric size)

L2: ø2 one-touch fitting
L4: ø4 one-touch fitting
L6: ø6 one-touch fitting (SJ3000 only)

(Inch size)

LN1: ø1/8" one-touch fitting
LN3: ø5/32" one-touch fitting
LN7: ø1/4" one-touch fitting (SJ3000 only)

Elbow fitting assembly (downward entry)
(Metric size)

B2: ø2 one-touch fitting
B4: ø4 one-touch fitting
B6: ø6 one-touch fitting (SJ3000 only)

(Inch size)

BN1: ø1/8" one-touch fitting
BN3: ø5/32" one-touch fitting
BN7: ø1/4" one-touch fitting (SJ3000 only)

Connector entry

C: Dedicated for centralised wiring

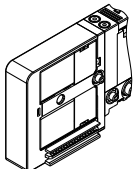

M: Individual wiring, with lead wire
Length 300 mm

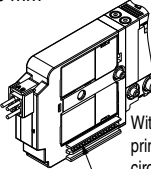

With linkage printed circuit board

MN: Individual wiring, without lead wire (with connector, socket)

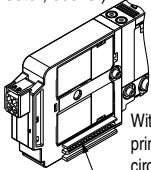

With linkage printed circuit board

MO: Individual wiring, without connector

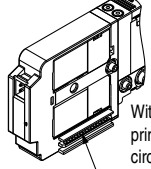

With linkage printed circuit board

Light/surge voltage suppressor

U	With light/surge voltage suppressor (non-polar type)
Z	With light/surge voltage suppressor (polar type)

Note 1) When the types with power saving circuit, with switches, and/or individual wiring are used, the non-polar type cannot be selected.

With switch

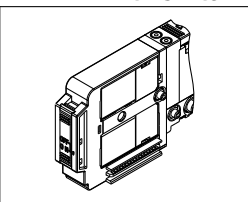

Manual override

—: Non-locking push type

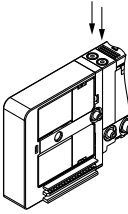

D: Push-turn locking slotted type

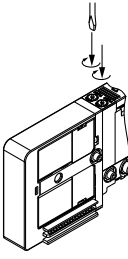

Note 1) Connector entries with the symbol "M□" can not use the switch signal from the common wiring on the manifold. For details, refer to "Connector Wiring Diagram" on page 3.
Note 2) When ordering a connector assembly separately, refer to back page 8.

Series SJ2000/3000

Manifold Electrical Wiring

Type 60G: Flat ribbon cable (20 pins, PC wiring with power supply terminal)

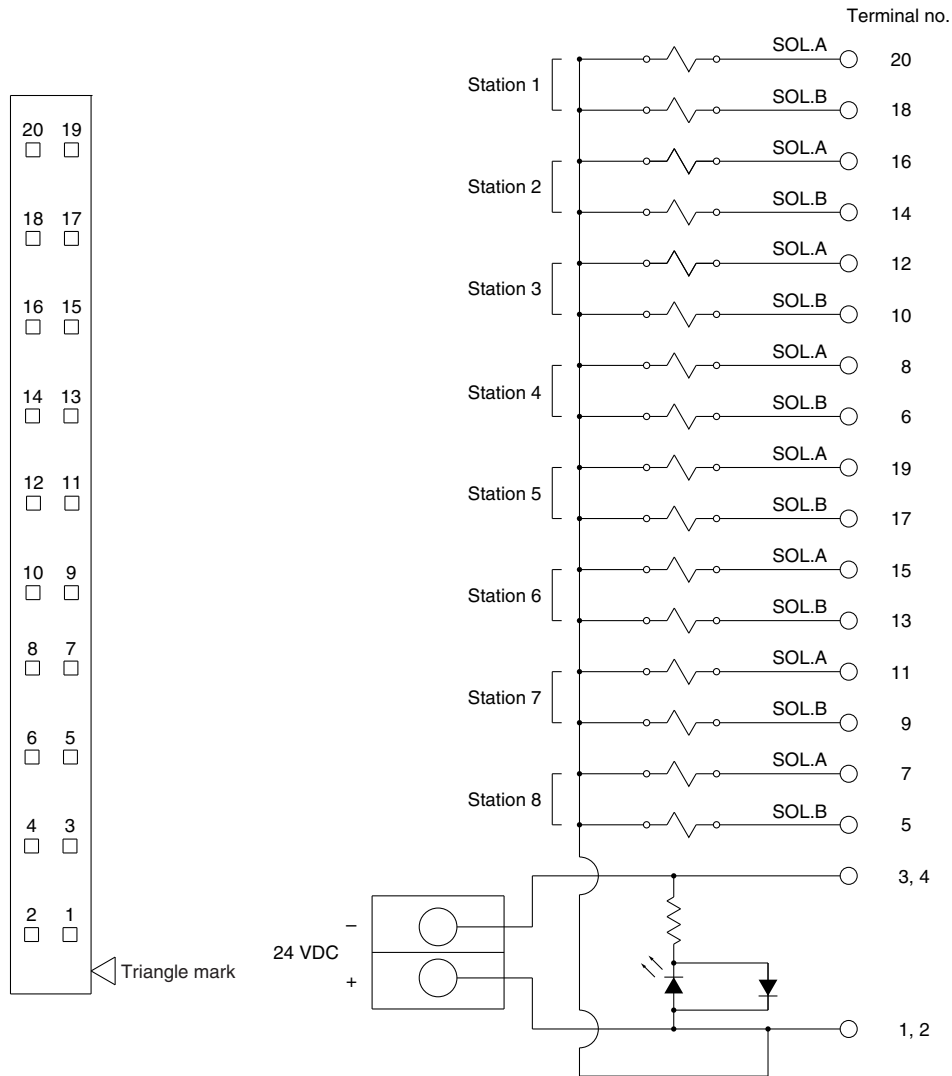

Note 1) This circuit is for the specifications with up to 8 stations of 2 position double, 3 position and 4 position dual 3 port valves. These should be wired in order 20→18→16→14 without skipping or leaving any connectors remaining.
 Note 2) For details on PC wiring systems, refer to "PC Wiring System" catalogue (CAT.ES02-20B).

Dimensions

SS5J2-60GD- Stations U (S, R, RS)

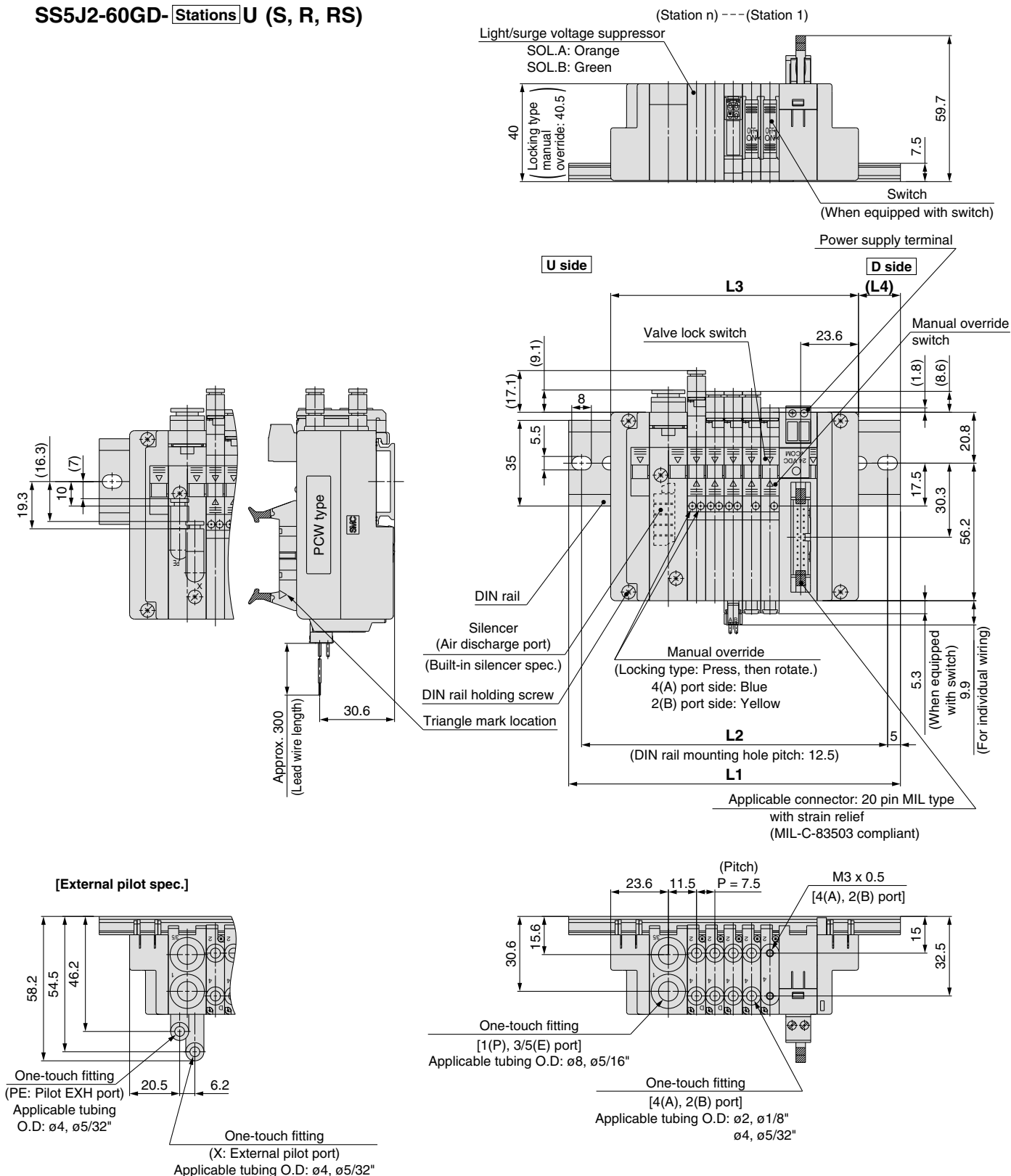

L: Dimensions

n: Stations

L	n	2	3	4	5	6	7	8	9	10
L1		110.5	110.5	123	135.5	135.5	148	148	160.5	173
L2		100	100	112.5	125	125	137.5	137.5	150	162.5
L3		78.7	86.2	93.7	101.2	108.7	116.2	123.7	131.2	138.7
L4		16	12	14.5	17	13.5	16	12	14.5	17

Series SJ2000/3000

Dimensions

SS5J2-60GD- Stations B (S, R, RS)

(Station n) --- (Station 1)

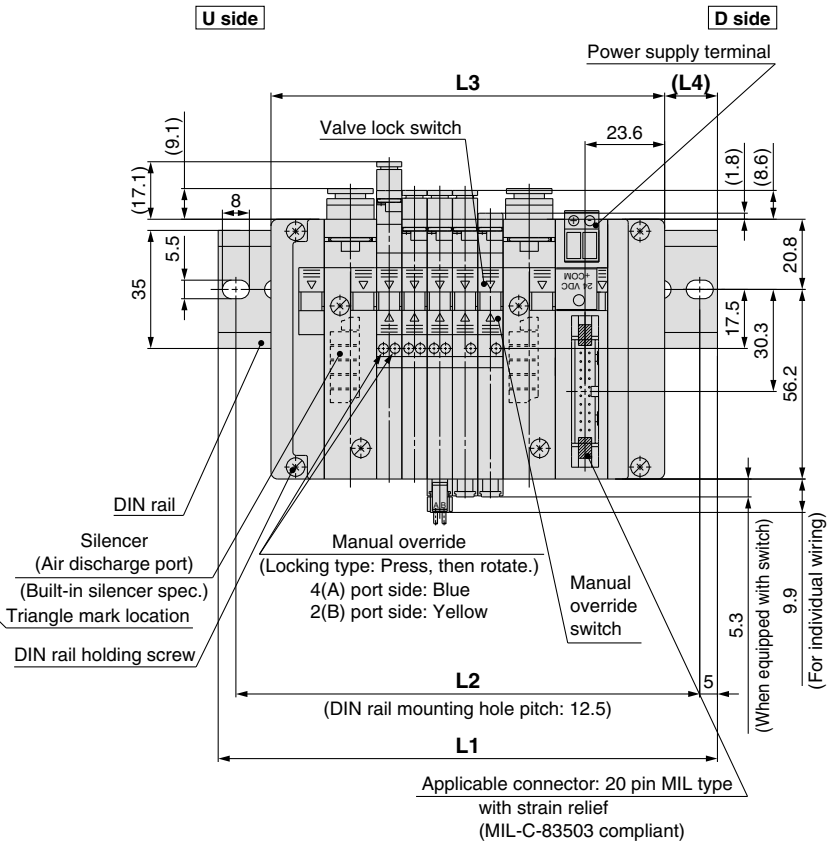
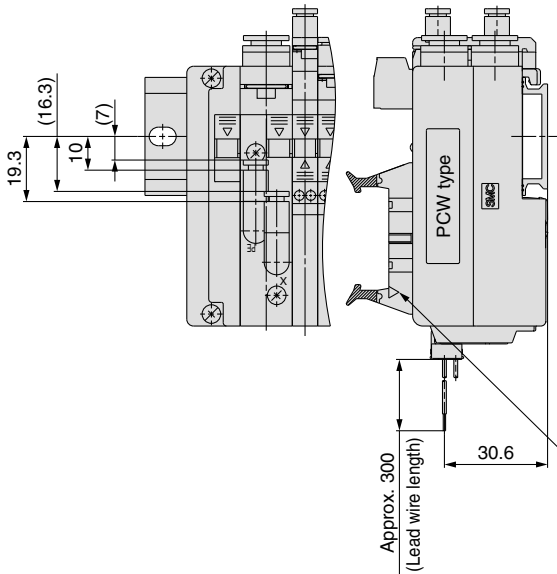
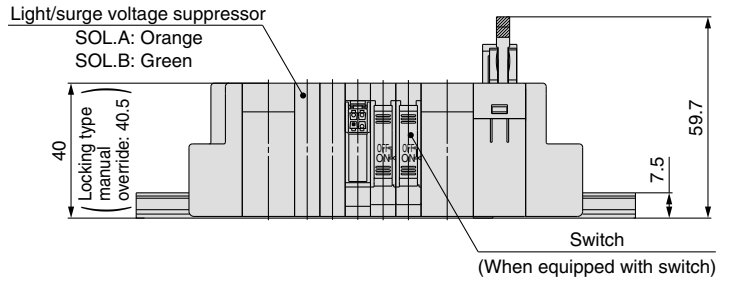

[External pilot spec.]

(There is a piping of X, PE port in the both sides.)

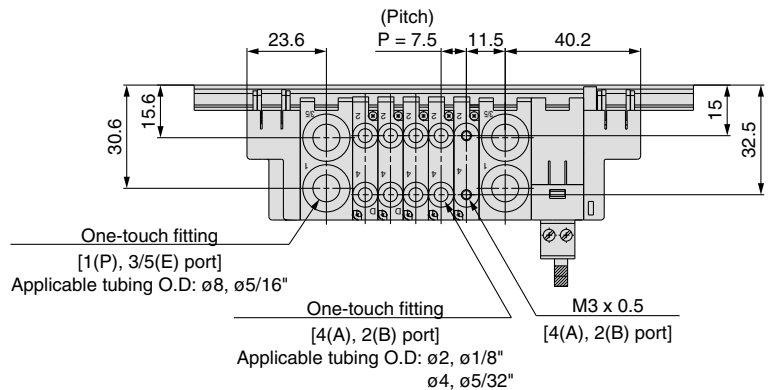
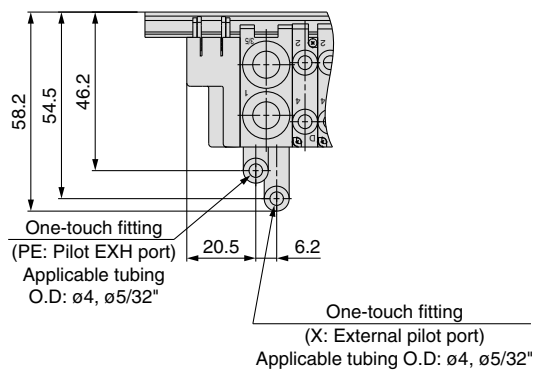

Note) For manifold dimensions including elbow fitting, refer to page 23.

L: Dimensions

n: Stations

L \ n	2	3	4	5	6	7	8	9	10	11	12	13	14	15	16
L1	123	135.5	135.5	148	148	160.5	173	173	185.5	185.5	198	210.5	210.5	223	223
L2	112.5	125	125	137.5	137.5	150	162.5	162.5	175	175	187.5	200	200	212.5	212.5
L3	94.2	101.7	109.2	116.7	124.2	131.7	139.2	146.7	154.2	161.7	169.2	176.7	184.2	191.7	199.2
L4	14.5	17	13	15.5	12	14.5	17	13	15.5	12	14.5	17	13	15.5	12

Dimensions

SS5J3-60GD- Stations U (S, R, RS)

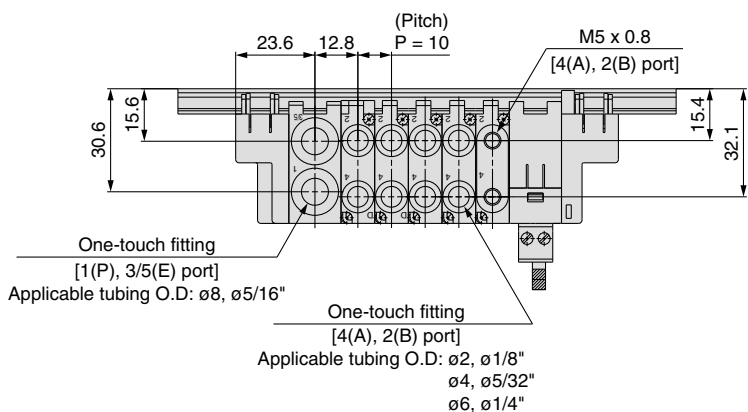
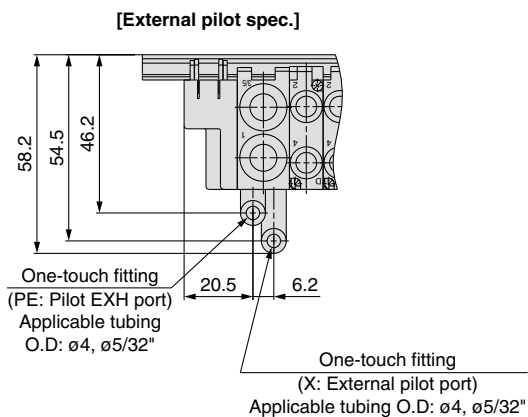
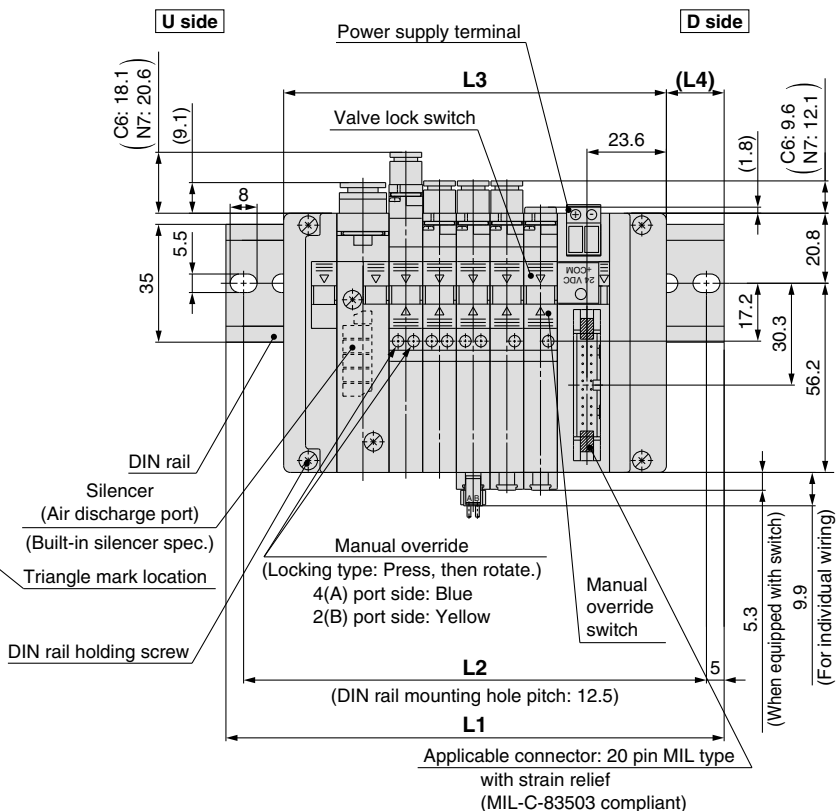
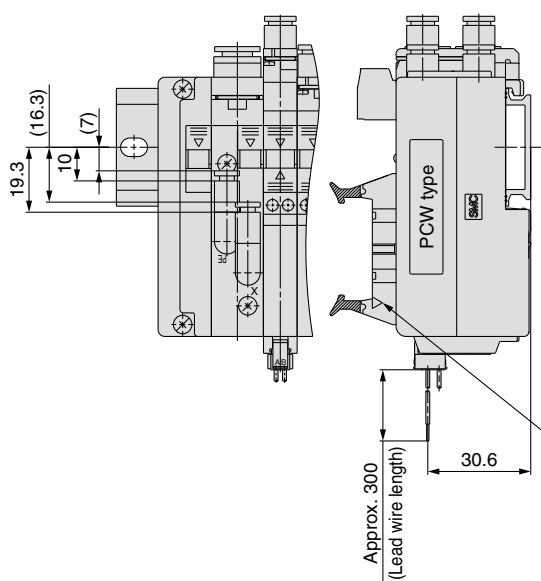
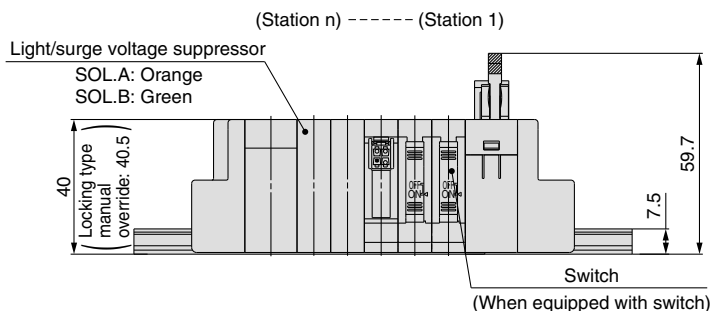

Note) For manifold dimensions including elbow fitting, refer to page 24.

L: Dimensions

n: Stations

L \ n	2	3	4	5	6	7	8	9	10
L1	110.5	123	135.5	148	148	160.5	173	185.5	198
L2	100	112.5	125	137.5	137.5	150	162.5	175	187.5
L3	83.7	93.7	103.7	113.7	123.7	133.7	143.7	153.7	163.7
L4	13	14.5	15.5	16.5	11.5	12.5	14	15	16

Series SJ2000/3000

Dimensions

SS5J3-60GD- Stations B (S, R, RS)

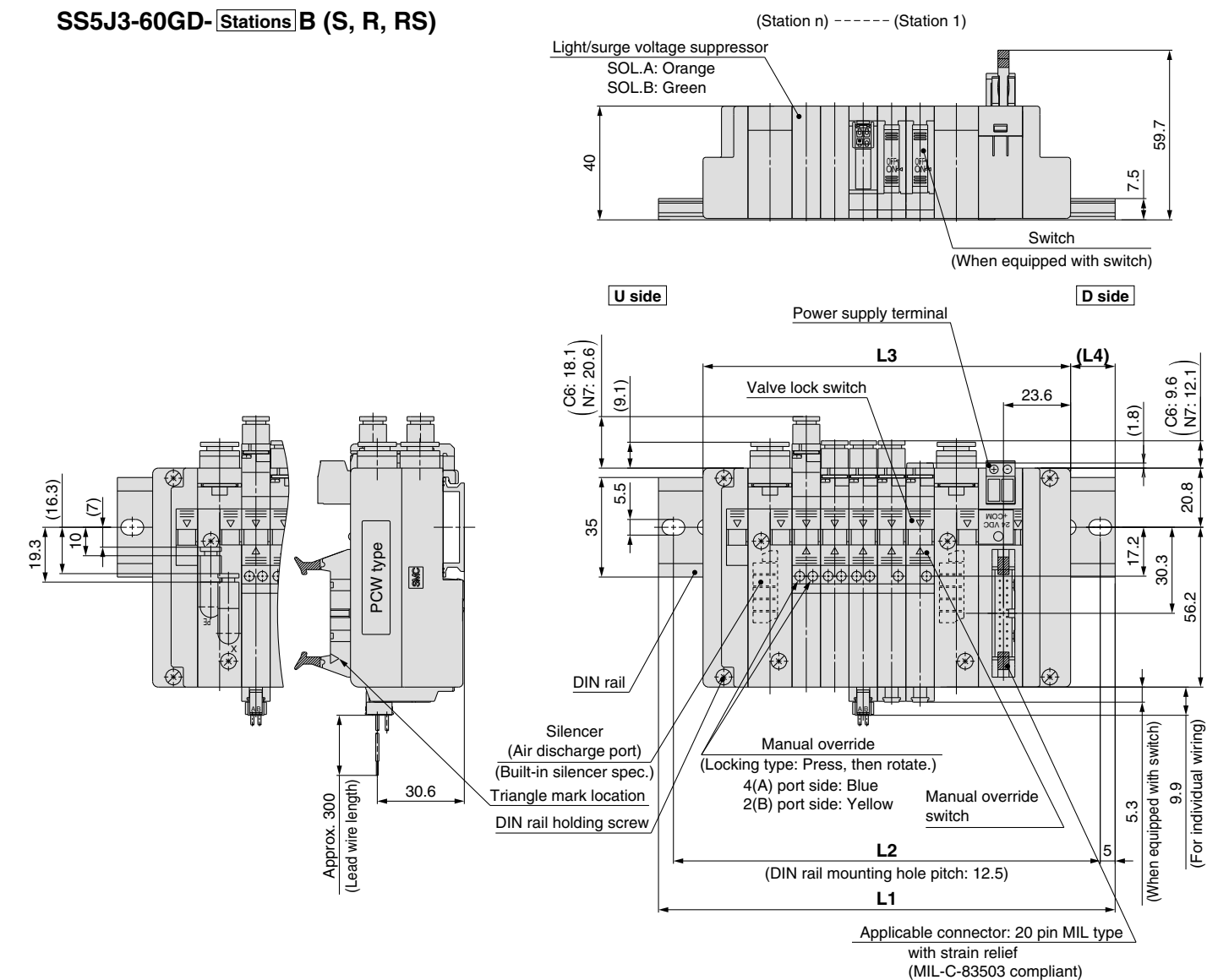

[External pilot spec.]

(There is a piping of X, PE port in the both sides.)

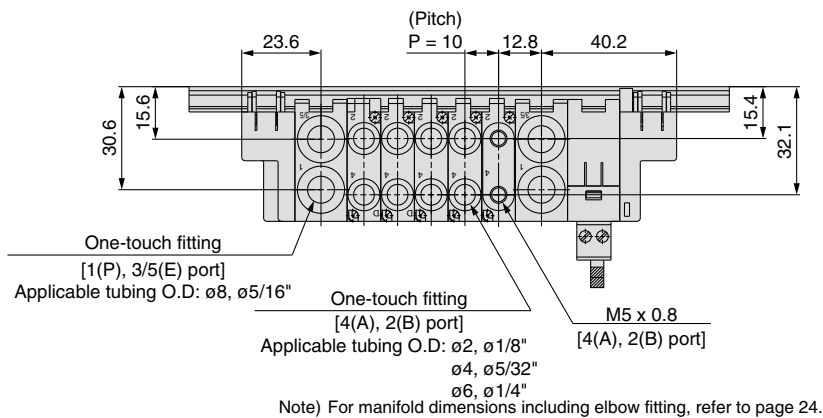
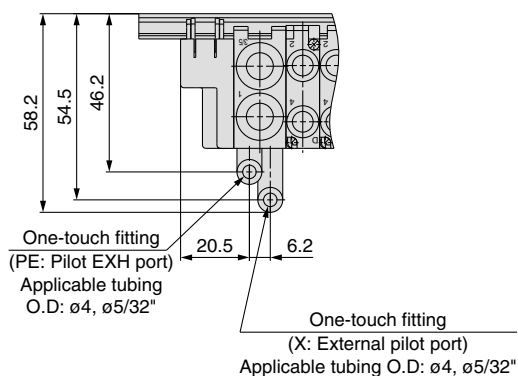

L: Dimensions

L	n	2	3	4	5	6	7	8	9	10	11	12	13	14	15	16
L1	n: Stations	123	135.5	148	160.5	173	185.5	185.5	198	210.5	223	235.5	235.5	248	260.5	273
L2		112.5	125	137.5	150	162.5	175	175	187.5	200	212.5	225	225	237.5	250	262.5
L3		99.2	109.2	119.2	129.2	139.2	149.2	159.2	169.2	179.2	189.2	199.2	209.2	219.2	229.2	239.2
L4		11.5	13	14	15	16.5	17.5	12.5	13.5	14.5	16	17	12	13	14	15.5

Dimensions

SS5J3-M60GD-Stations U (S, R, RS)

L dimension: Formula, L1 to L4

$$L3 = 7.5 \times n1 + 10 \times n2 + 63.7$$

$$M = (L3 + 4) / 12.5 + 1$$

Remove all numbers after the decimal.

$$L1 = M \times 12.5 + 23$$

$$L2 = L1 - 10.5$$

$$L4 = (L1 - L3) / 2 - 2$$

n1: Piece of the SJ2000

n2: Piece of the SJ3000

Note) The dimensions of L1 to L4 for **SS5J3-M60GD-StationsD** are the same as those of **SS5J3-M60GD-StationsU**.

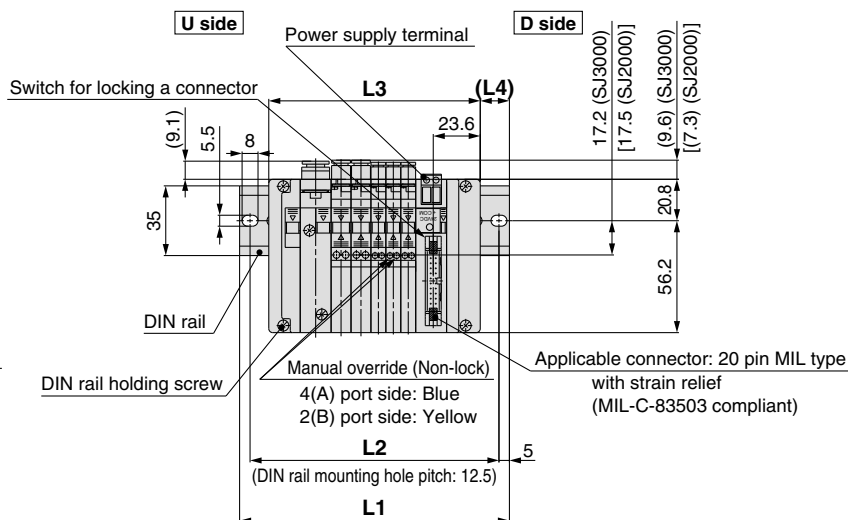
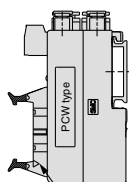
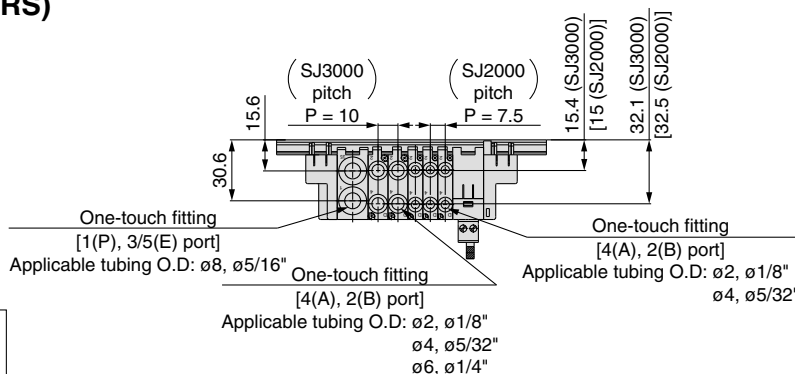

SS5J3-M60GD-Stations B (S, R, RS)

L dimension: Formula, L1 to L4

$$L3 = 7.5 \times n1 + 10 \times n2 + 79.2$$

$$M = (L3 + 4) / 12.5 + 1$$

Remove all numbers after the decimal.

$$L1 = M \times 12.5 + 23$$

$$L2 = L1 - 10.5$$

$$L4 = (L1 - L3) / 2 - 2$$

n1: Piece of the SJ2000

n2: Piece of the SJ3000

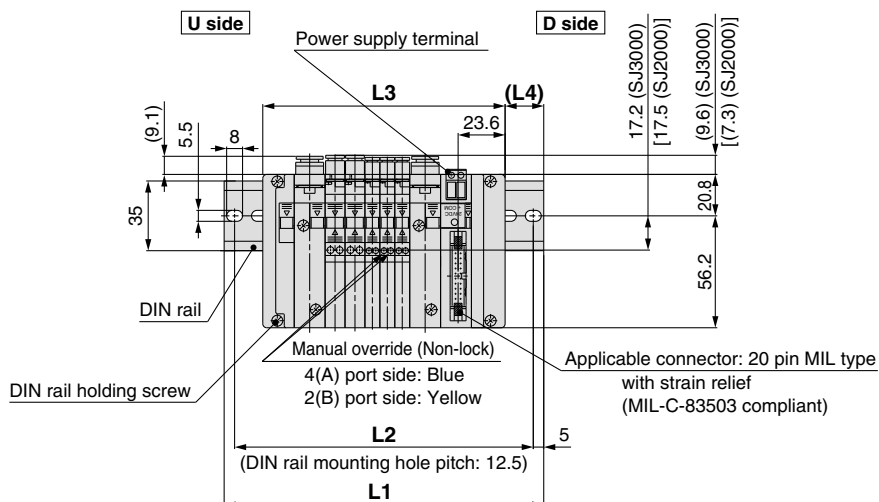
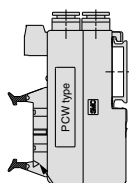
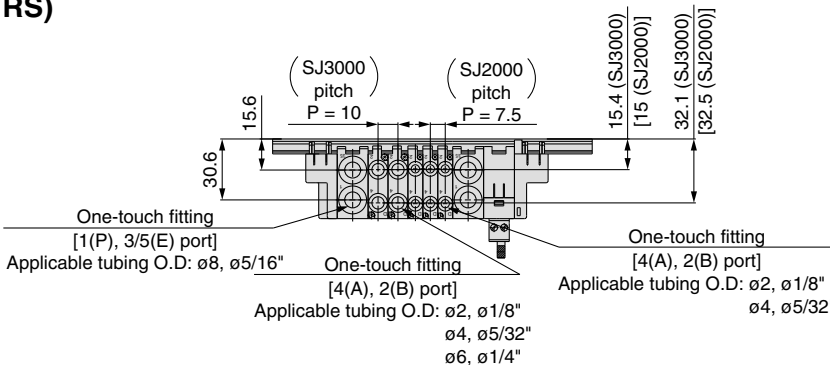

Plug-in Connector Type

EX180 Serial Wiring

Series SJ2000/3000



Type 60S

How to Order

SS5J3-60SV D-05U

Series

2	SJ2000
3	SJ3000 (SJ2000/3000 mixed)

Mixed mounting type

—	Standard ^{Note 1)}
M	Mixed mounting ^{Note 2)}

Note 1) There is no need to enter anything when you order either the SJ2000 or SJ3000 series alone.
 Note 2) Enter "M" when the SJ2000 or SJ3000 series will be mounted on the same manifold base together.

Component module

0	Without SI unit
V2	Mitsubishi Electric Corporation: CC-Link compliant (32 points)
Q2	DeviceNet compliant (32 points)
Q3	DeviceNet compliant (16 points)

Note) Please contact SMC for a specification of the SI unit.

Communication connector spec.

—	T-branch type
A	Straight type

Note) Communication connector, power connector are shipped together with manifold. Power connector is available of straight type only.

DIN rail length specified

—	Standard length	
3	3 stations	Specify a longer rail than the standard length.
⋮	⋮	
32	32 stations	

Note) Specify the valve stations not exceeding the maximum stations.

SUP/EXH block fitting spec.

—	Straight fitting	
L	Elbow fitting (Upward)	
B	Elbow fitting (Downward)	

Note) There is no need to enter anything when the SUP/EXH block mounting position "M" is selected.

Pilot spec.

—	Internal pilot
S	Internal pilot / Built-in silencer
R	External pilot
RS	External pilot / Built-in silencer

Note 1) There is no need to enter anything when the SUP/EXH block mounting position "M" is selected.
 Note 2) For built-in silencers, the 3/5(E) ports are plugged.

How to Order Valve Manifold Assembly

Ordering example (SS5J3-60SV□-□)

Double solenoid, individual wiring/lead wire length 300 mm (24 VDC)
 SJ3260-5MZ-C6 (1 set)

Double solenoid, with switch (24 VDC)
 SJ3260-5CZJ-C6 (1 set)

Double solenoid (24 VDC)
 SJ3260-5CU-C6 (2 sets)

Single solenoid (24 VDC)
 SJ3160-5CU-C6 (2 sets)

SS5J3-60SV2D-06D-1 set (Manifold part no.)

- * SJ3160-5CU-C62 sets (Single solenoid part no.)
- * SJ3260-5CU-C62 sets (Double solenoid part no.)
- * SJ3260-5CZJ-C61 set (Double solenoid, with switch part no.)
- * SJ3260-5MZ-C61 set (Double solenoid, individual wiring/lead wire length 300 mm part no.)

→The asterisk denotes the symbol for assembly.
 Prefix to the part no. of the solenoid valve, etc.

- The valve arrangement is numbered as the 1st station from D side.
- Indicate the valves to be attached below the manifold part number, in order starting from station 1 as shown in the drawing.
- In the case of complex arrangement, specify them in the manifold specification sheet.

SUP/EXH block mounting position

U	U side (2 to 10 stations)
D	D side (2 to 10 stations)
B	Both sides (2 to 32 stations)
M ^{Note)}	Special specifications

Note) Specify the required specifications (including port sizes other than ø8) by using a manifold specification sheet.

Valve stations

Symbol	Stations	Note
02	2 stations	Up to 32 solenoids possible.
⋮	⋮	
32	32 stations	

Note) The number of the blanking block assembly is also included. Since single and double wiring are available with the blanking block assembly, select a model compatible with the valve wiring spec. planned for the future. (Refer to page 61.)

SI Unit Part No.

Symbol	Component module/Communication connector specifications	For SS5J□-60S
V2	Mitsubishi Electric Corp. CC-LINK compliant (32 points, NPN), T-branch type	EX180-SMJ3
V2A	Mitsubishi Electric Corp. CC-LINK compliant (32 points, NPN), Straight type	EX180-SMJ3A
V2N	Mitsubishi Electric Corp. CC-LINK compliant (32 points, PNP), T-branch type	EX180-SMJ5
V2NA	Mitsubishi Electric Corp. CC-LINK compliant (32 points, PNP), Straight type	EX180-SMJ5A
Q2	DeviceNet compliant (32 points), T-branch type	EX180-SDN3
Q2A	DeviceNet compliant (32 points), Straight type	EX180-SDN3A
Q3	DeviceNet compliant (16 points), T-branch type	EX180-SDN4
Q3A	DeviceNet compliant (16 points), Straight type	EX180-SDN4A

Item		Specifications
Power source for driving valve	Non-polar	24 VDC + 10%/−5%
	With energy saving circuit (continuous duty)	24 VDC + 10%/0%

How to Order Solenoid Valves

Standard

With switch

Individual wiring
[for plug-in mixed mounting] Note)

SJ 3 1 60 [] [] [] - **5** **C U** [] - **C6** - []

SJ 3 1 60 [] [] [] - **5** **C Z J** [] - **C6** - []

SJ 3 1 60 [] [] [] - **5** **M Z** [] - **C6**

Single solenoid wiring spec.

—	Single wiring
D	Double wiring

Note) There is no need to enter anything for 2 position double, 3 position and 4 position solenoid valves. Select this when the unused numbers to wiring are set. Refer to page 3 for details.

Note) Refer to pages 52 and 53 for the dedicated non-plug-in individual wiring.

Series

2	SJ2000
3	SJ3000

Back pressure check valve

—	None
K	Built-in

Note) Back pressure check valve is not applicable for 3 position valve.

Pilot spec.

—	Internal pilot
R	External pilot

Note) External pilot spec. is not applicable for 4 position dual 3 port valves.

Coil spec.

—	Standard
T	With power saving circuit (continuous duty type)

Note) Be sure to select "with power saving circuit" when the solenoid valve will be energised continuously for long period.

Rated voltage

5	24 VDC
----------	--------

Type of actuation

1	2 position single solenoid
2	2 position double solenoid
3	3 position closed centre
4	3 position exhaust centre
5	3 position pressure centre
A	Dual 3 port valve: N.C./N.C.
B	Dual 3 port valve: N.O./N.O.
C	Dual 3 port valve: N.C./N.O.

Note) Refer to pages 4 through to 7 for the JIS symbol.

Connector entry

C: Dedicated for centralized wiring

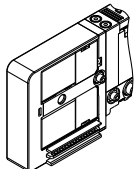

M: Individual wiring, with lead wire
Length 300 mm

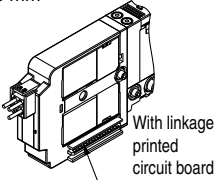

With linkage printed circuit board

MN: Individual wiring, without lead wire (with connector, socket)

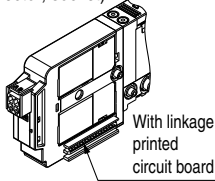

With linkage printed circuit board

MO: Individual wiring, without connector

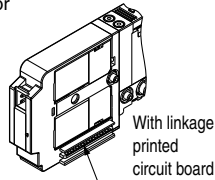

With linkage printed circuit board

Light/surge voltage suppressor

U	With light/surge voltage suppressor (non-polar type)
Z	With light/surge voltage suppressor (polar type)

Note 1) When the types with power saving circuit, with switches, and/or individual wiring are used, the non-polar type cannot be selected.

With switch

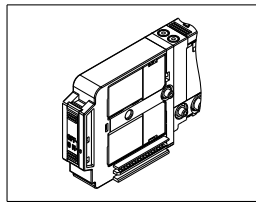

Manual override

—: Non-locking push type

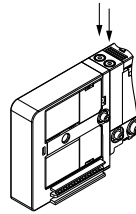

D: Push-turn locking slotted type

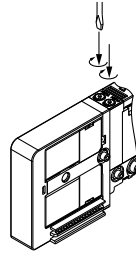

Note 1) Connector entries with the symbol "M□" can not use the switch signal from the common wiring on the manifold. For details, refer to "Connector Wiring Diagram" on page 3.
Note 2) When ordering a connector assembly separately, refer to back page 8.

A, B port size

Straight (Metric size)

C2: ø2 one-touch fitting

C4: ø4 one-touch fitting

C6: ø6 one-touch fitting (SJ3000 only)

(Inch size)

N1: ø1/8" one-touch fitting

N3: ø5/32" one-touch fitting

N7: ø1/4" one-touch fitting (SJ3000 only)

(Thread piping)

M3: M3 x 0.5 (SJ2000 only)

M5: M5 x 0.8 (SJ3000 only)

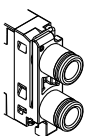
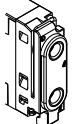
Elbow fitting assembly (upward entry) (Metric size)

L2: ø2 one-touch fitting

L4: ø4 one-touch fitting

L6: ø6 one-touch fitting (SJ3000 only)

(Inch size)

LN1: ø1/8" one-touch fitting

LN3: ø5/32" one-touch fitting

LN7: ø1/4" one-touch fitting (SJ3000 only)

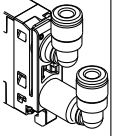

Elbow fitting assembly (downward entry) (Metric size)

B2: ø2 one-touch fitting

B4: ø4 one-touch fitting

B6: ø6 one-touch fitting (SJ3000 only)

(Inch size)

BN1: ø1/8" one-touch fitting

BN3: ø5/32" one-touch fitting

BN7: ø1/4" one-touch fitting (SJ3000 only)

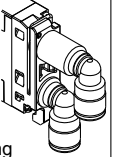



Series SJ2000/3000

Dimensions: SJ2000 for EX180 Serial Wiring

SS5J2-60S□□D-Stations U (S, R, RS)

(Station n) --- (Station 1)

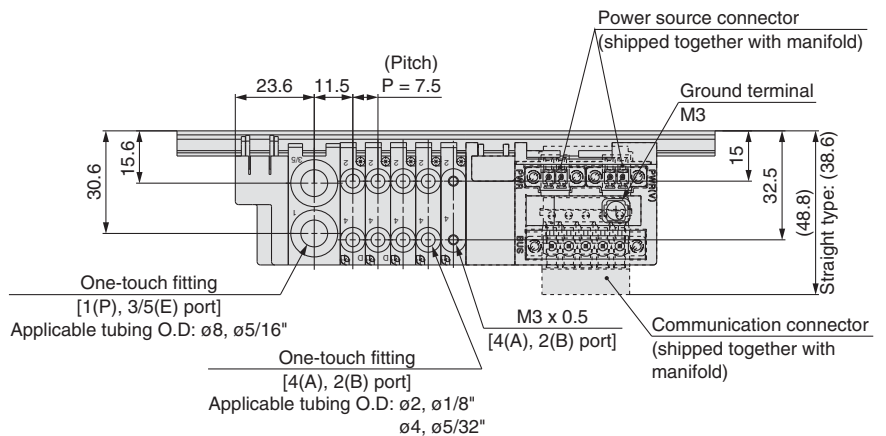
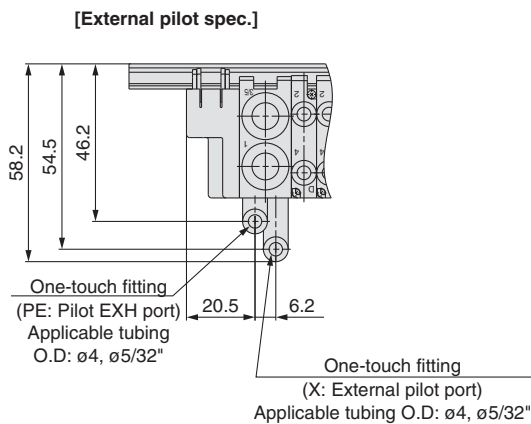
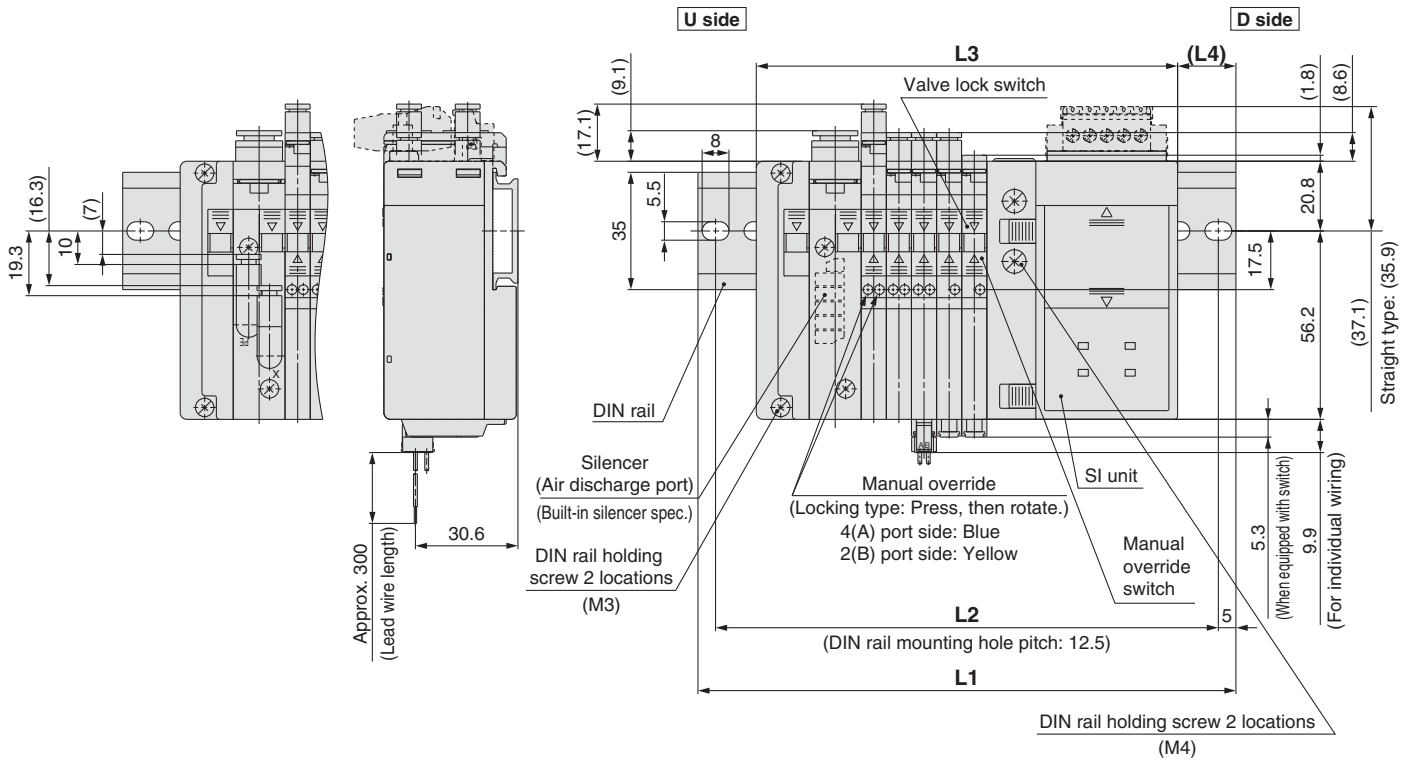
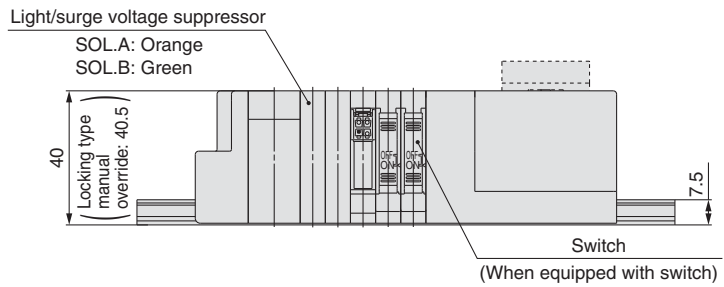

Note) For manifold dimensions including elbow fitting, refer to page 23. Please contact SMC regarding the SI unit.

L: Dimensions

n: Stations

L	n	2	3	4	5	6	7	8	9	10
L1		135.5	135.5	148	160.5	160.5	173	173	185.5	198
L2		125	125	137.5	150	150	162.5	162.5	175	187.5
L3		103.2	110.7	118.2	125.7	133.2	140.7	148.2	155.7	163.2
L4		16	12.5	15	17.5	13.5	16	12.5	15	17.5

Dimensions: SJ2000 for EX180 Serial Wiring

SS5J2-60S□□D-**Stations** B (S, R, RS)

(Station n) --- (Station 1)
Light/surge voltage suppressor

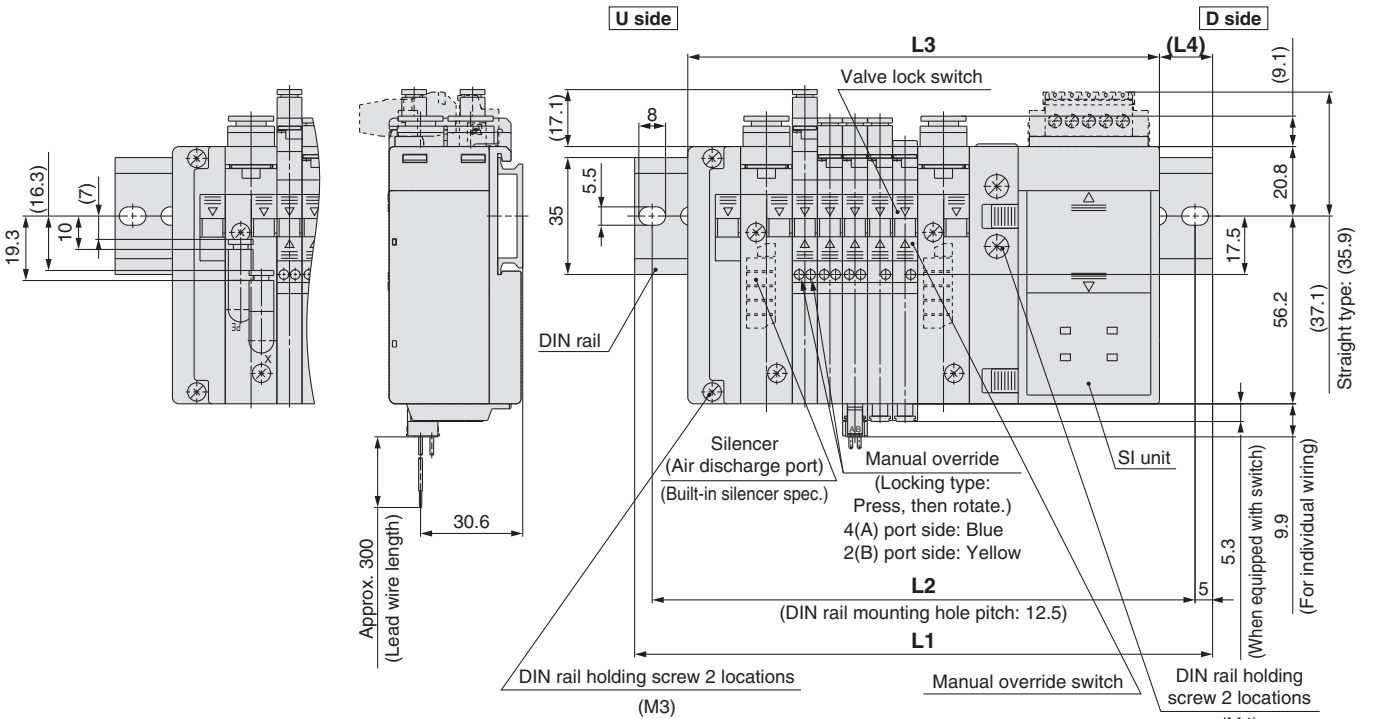
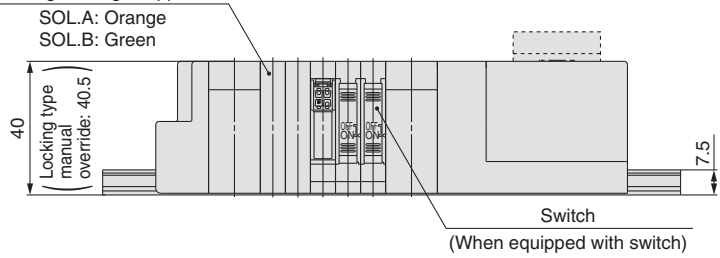

[External pilot spec.]
(There is a piping of X, PE port in the both sides.)

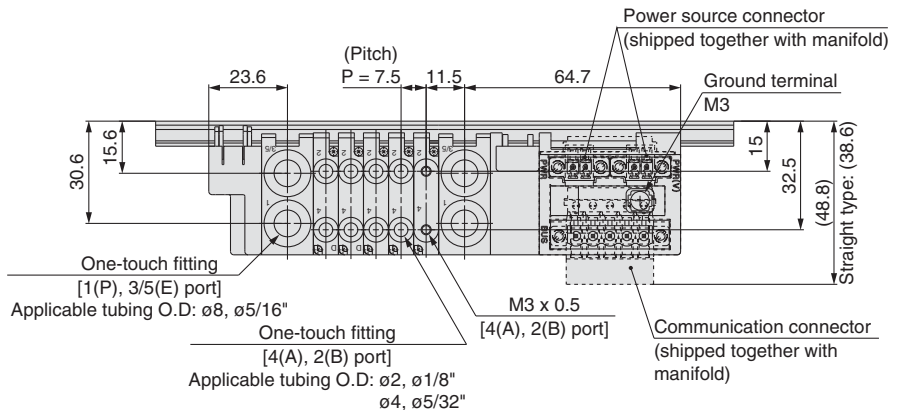
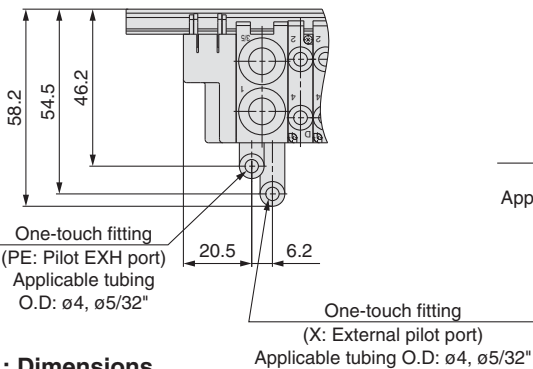

Note) For manifold dimensions including elbow fitting, refer to page 23.
Please contact SMC regarding the SI unit.

L: Dimensions

L \ n	2	3	4	5	6	7	8	9	10	11	12	13	14	15	16	17
L1	148	160.5	160.5	173	173	185.5	198	198	210.5	210.5	223	235.5	235.5	248	248	260.5
L2	137.5	150	150	162.5	162.5	175	187.5	187.5	200	200	212.5	225	225	237.5	237.5	250
L3	118.7	126.2	133.7	141.2	148.7	156.2	163.7	171.2	178.7	186.2	193.7	201.2	208.7	216.2	223.7	231.2
L4	14.5	17	13.5	16	12	14.5	17	13.5	16	12	14.5	17	13.5	16	12	14.5

L \ n	18	19	20	21	22	23	24	25	26	27	28	29	30	31	32
L1	273	273	285.5	285.5	298	310.5	310.5	323	323	335.5	348	348	360.5	360.5	373
L2	262.5	262.5	275	275	287.5	300	300	312.5	312.5	325	337.5	337.5	350	350	362.5
L3	238.7	246.2	253.7	261.2	268.7	276.2	283.7	291.2	298.7	306.2	313.7	321.2	328.7	336.2	343.7
L4	17	13.5	16	12	14.5	17	13.5	16	12	14.5	17	13.5	16	12	14.5

Series SJ2000/3000

Dimensions: SJ3000 for EX180 Serial Wiring

SS5J3-60S□□D-**Stations** U (S, R, RS) Light/surge voltage suppressor

SOL.A: Orange
SOL.B: Green

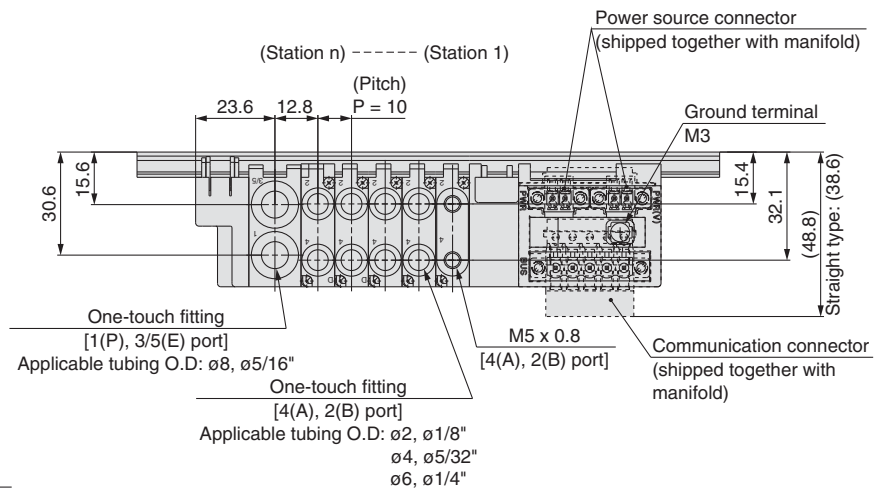
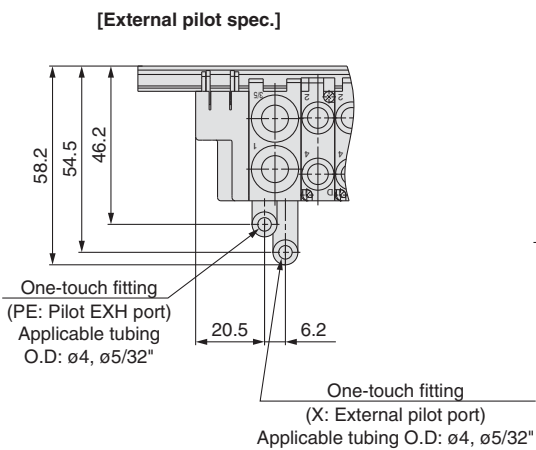
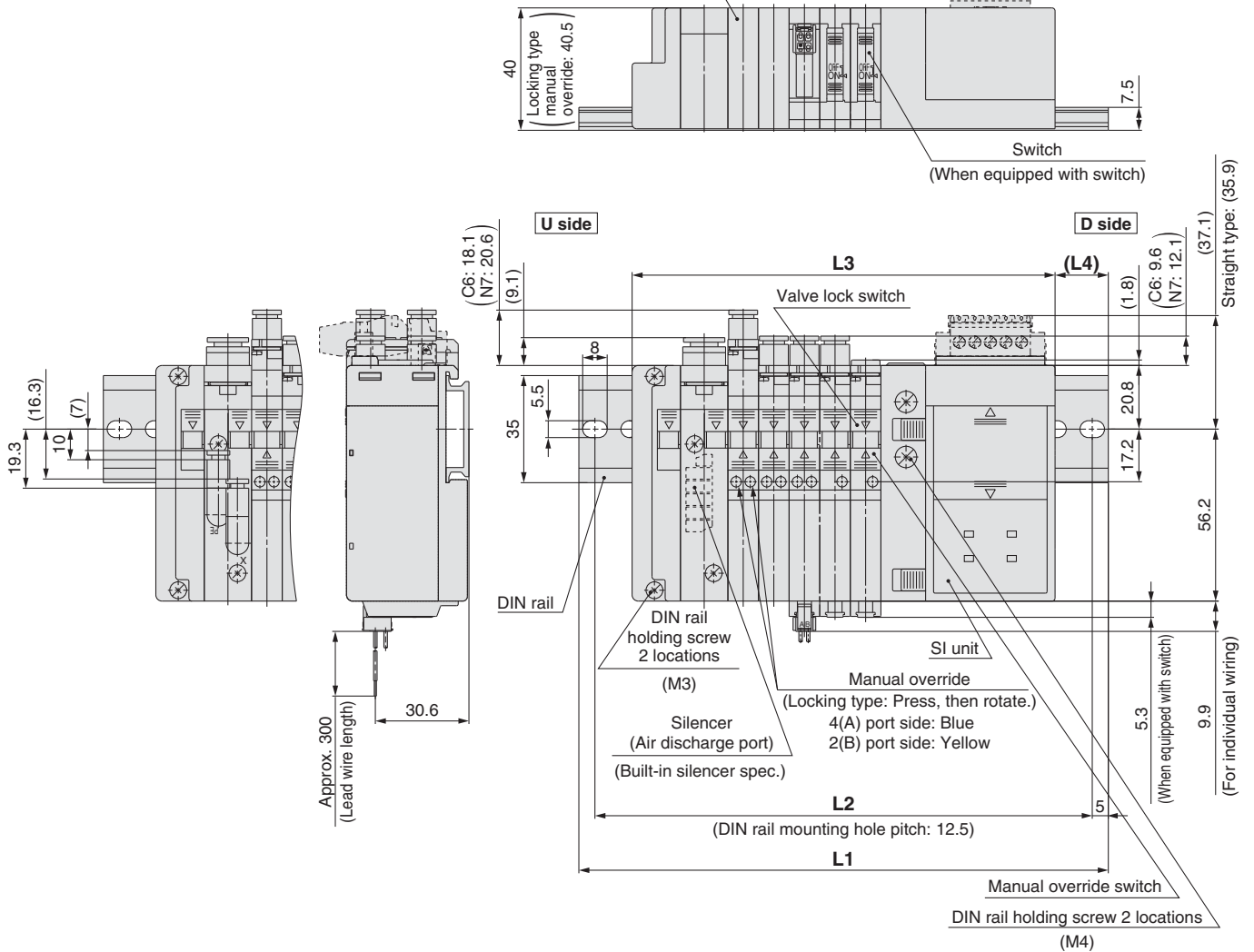

L: Dimensions n: Stations

L \ n	2	3	4	5	6	7	8	9	10
L1	135.5	148	160.5	173	173	185.5	198	210.5	223
L2	125	137.5	150	162.5	162.5	175	187.5	200	212.5
L3	108.2	118.2	128.2	138.2	148.2	158.2	168.2	178.2	188.2
L4	13.5	14.5	16	17	12	13	14	15.5	16.5

Note) For manifold dimensions including elbow fitting, refer to page 24. Please contact SMC regarding the SI unit.

Dimensions: SJ3000 for EX180 Serial Wiring

SS5J3-60S□□D-**Stations** B (S, R, RS)

(Station n) ----- (Station 1)

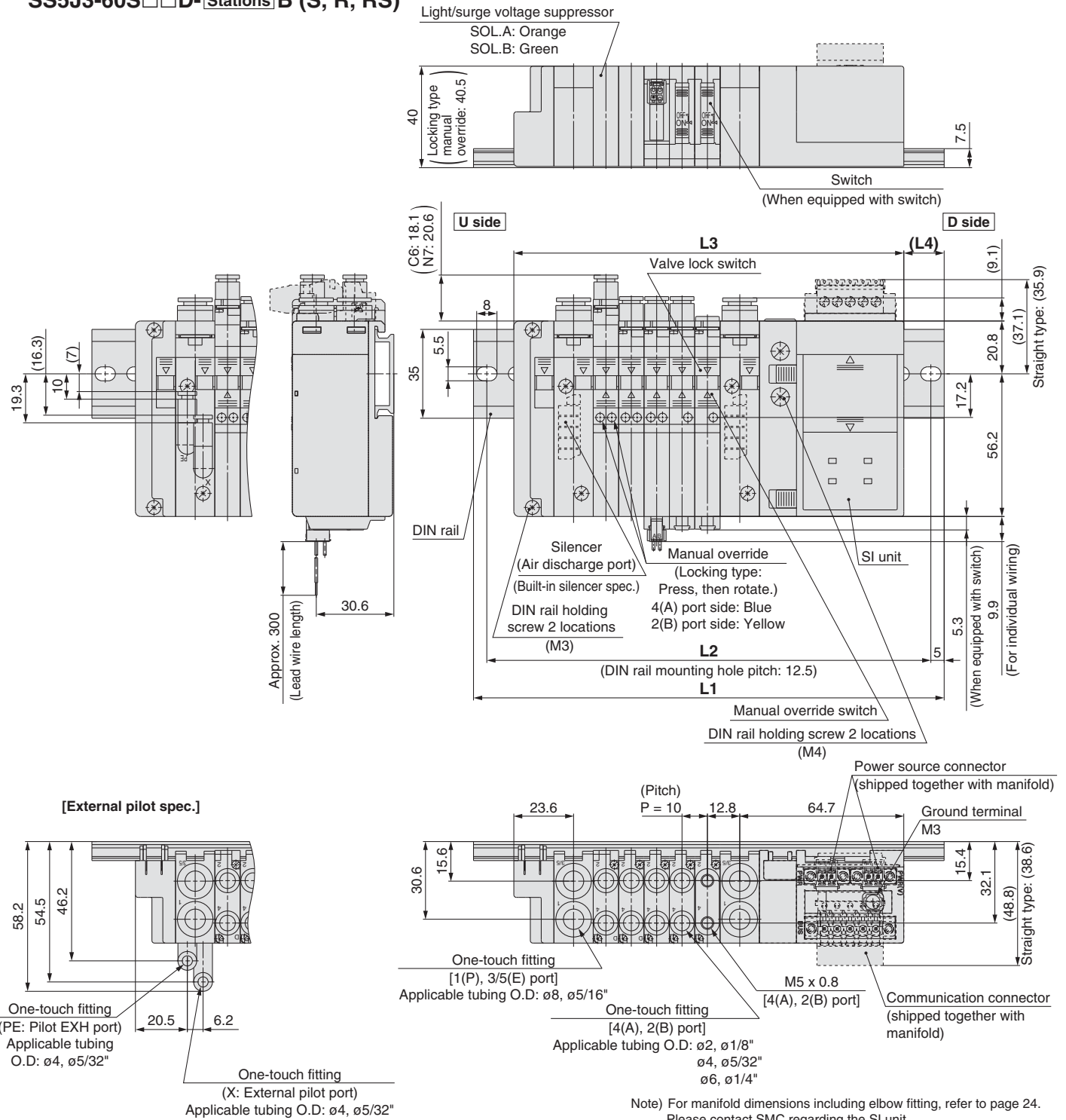

Note) For manifold dimensions including elbow fitting, refer to page 24. Please contact SMC regarding the SI unit.

n: Stations

L: Dimensions

L \ n	2	3	4	5	6	7	8	9	10	11	12	13	14	15	16	17
L1	148	160.5	173	185.5	198	210.5	210.5	223	235.5	248	260.5	260.5	273	285.5	298	310.5
L2	137.5	150	162.5	175	187.5	200	200	212.5	225	237.5	250	250	262.5	275	287.5	300
L3	123.7	133.7	143.7	153.7	163.7	173.7	183.7	193.7	203.7	213.7	223.7	233.7	243.7	253.7	263.7	273.7
L4	12	13	14.5	15.5	16.5	17.5	12.5	14	15	16	17	12	13.5	14.5	15.5	16.5

L \ n	18	19	20	21	22	23	24	25	26	27	28	29	30	31	32
L1	310.5	323	335.5	348	360.5	373	373	385.5	398	410.5	423	423	435.5	448	460.5
L2	300	312.5	325	337.5	350	362.5	362.5	375	387.5	400	412.5	412.5	425	437.5	450
L3	283.7	293.7	303.7	313.7	323.7	333.7	343.7	353.7	363.7	373.7	383.7	393.7	403.7	413.7	423.7
L4	11.5	13	14	15	16	17.5	12.5	13.5	14.5	15.5	17	12	13	14	15

Series SJ2000/3000

Dimensions: SJ2000/3000 Mixed Manifold

SS5J3-M60S□□-[Stations] U (S, R, RS)

L dimension: Formula, L1 to L4
 $L3 = 7.5 \times n1 + 10 \times n2 + 88.2$
 $M = (L3 + 4) / 12.5 + 1$
 Remove all numbers after the decimal.
 $L1 = M \times 12.5 + 23$
 $L2 = L1 - 10.5$
 $L4 = (L1 - L3) / 2 - 2$

n1: Piece of the SJ2000
 n2: Piece of the SJ3000

Note) The dimensions of L1 to L4 for
SS5J3-M60S□□-[Stations] D are the same
 as those of **SS5J3-M60S□□-[Stations] U**.

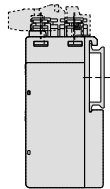
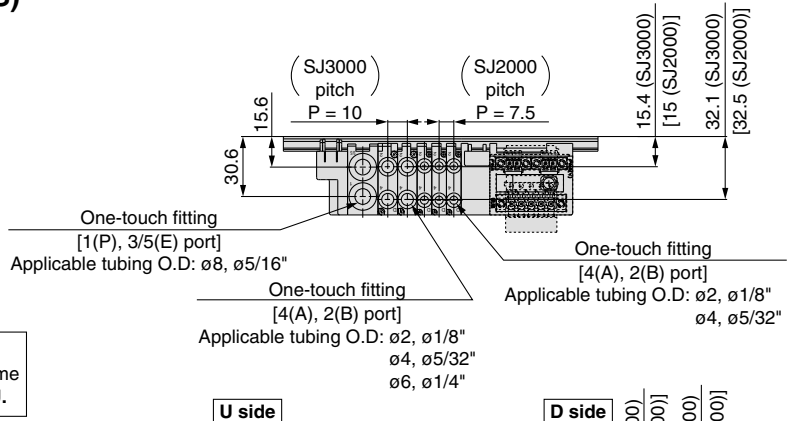

SS5J3-M60S□□-[Stations] B (S, R, RS)

L dimension: Formula, L1 to L4
 $L3 = 7.5 \times n1 + 10 \times n2 + 103.7$
 $M = (L3 + 4) / 12.5 + 1$
 Remove all numbers after the decimal.
 $L1 = M \times 12.5 + 23$
 $L2 = L1 - 10.5$
 $L4 = (L1 - L3) / 2 - 2$

n1: Piece of the SJ2000
 n2: Piece of the SJ3000

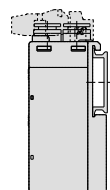
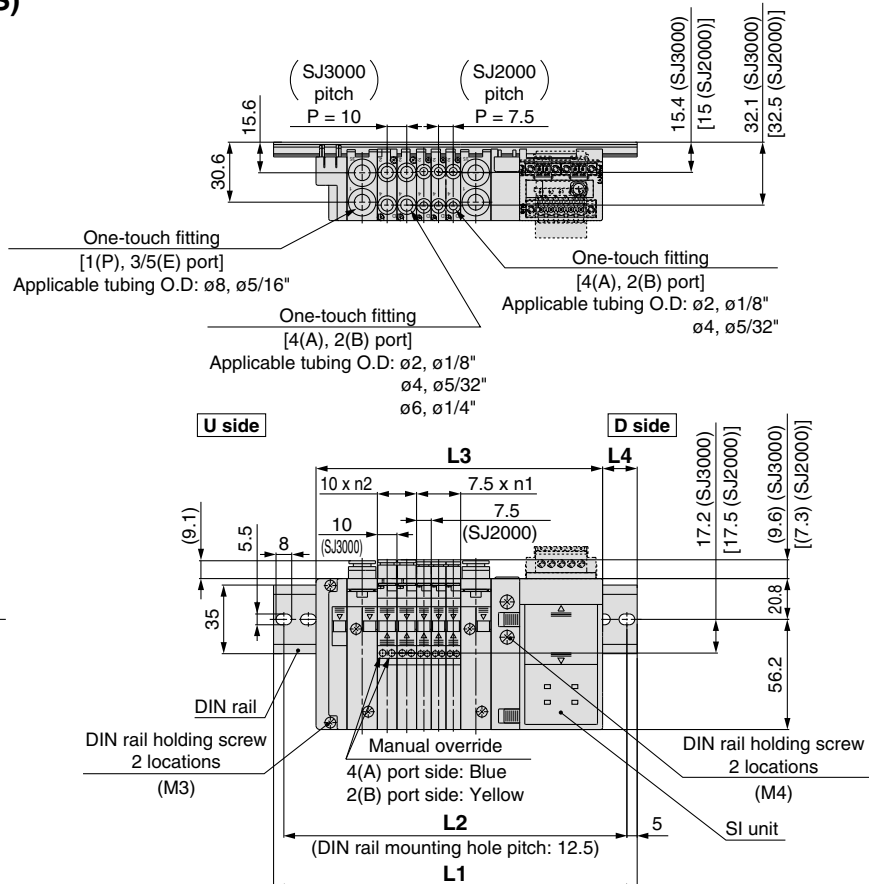

Plug-in Connector Type EX510 Gateway System Serial Transmission System

Type **60S6B**

Series *SJ2000/3000*



How to Order Manifold

SS5J 3 - **60S6B** **D** - **05 D**

Manifold series

2	SJ2000
3	SJ3000 (SJ2000/3000 mixed)

Mixed mounting type

—	Standard <small>Note 1)</small>
M	Mixed mounting <small>Note 2)</small>

Note 1) There is no need to enter anything when you order either the SJ2000 or SJ3000 series alone.

Note 2) Enter "M" when the SJ2000 or SJ3000 series will be mounted on the same manifold base together.

SI unit COM. spec.

—	+COM.
N	-COM.

Unit mounting position

D	D side
---	--------

Valve stations

Symbol	No. of stations	Note
02	2 stations	Up to 16 solenoids possible.
⋮	⋮	
16	16 stations	

Note) The number of the blanking block assembly is also included. Since single and double wiring are available with the blanking block assembly, select a model compatible with the valve wiring spec. planned for the future.

DIN rail length specified

—	Standard length	
3	3 stations	Specify a longer rail than the standard length.
⋮	⋮	
16	16 stations	

Note) Specify the valve stations not exceeding the maximum stations.

SUP/EXH block fitting spec.

—	Straight fitting	
—	With external pilot spec. X, PE port	
L	Elbow fitting (Upward)	
L	With external pilot spec. X, PE port	
B	Elbow fitting (Downward)	
B	With external pilot spec. X, PE port	

Note) There is no need to enter anything when the SUP/EXH block mounting position "M" is selected.

Pilot spec.

—	Internal pilot
S	Internal pilot / Built-in silencer
R	External pilot
RS	External pilot / Built-in silencer

Note 1) There is no need to enter anything when the SUP/EXH block mounting position "M" is selected.

Note 2) For built-in silencers, the 3/5(E) ports are plugged.

SUP/EXH block mounting position

U	U side (2 to 10 stations)
D	D side (2 to 10 stations)
B	Both sides (2 to 16 stations)
M <small>Note)</small>	Special specifications

Note) Specify the required specifications (including port sizes other than ø8) by using a manifold specification sheet.

How to Order Valve Manifold Assembly

Ordering example (SS5J3-60S6BD-□)

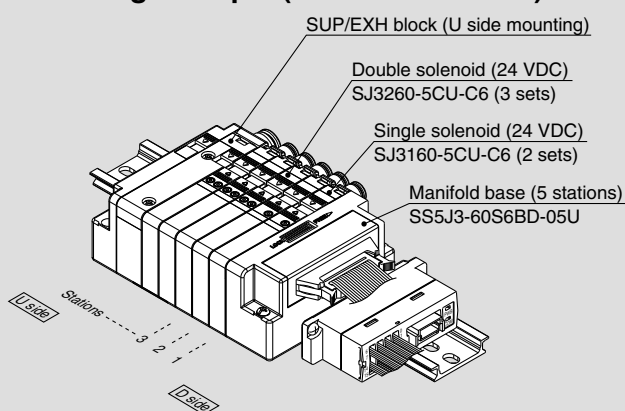

SS5J3-60S6BD-05U 1 set (Type 60S6B, 5 station manifold base part no.)

* SJ3160-5CU-C6 2 sets (Single solenoid part no.)

* SJ3260-5CU-C6 3 sets (Double solenoid part no.)

— The asterisk denotes the symbol for assembly.
Prefix to the part no. of the solenoid valve, etc.

- The valve arrangement is numbered as the 1st station from D side.
- Indicate the valves to be attached below the manifold part number, in order starting from station 1 as shown in the drawing.
- In the case of complex arrangement, specify them in the manifold specification sheet.



For details on "Gateway System Serial Transmission System Series EX510," refer to CAT.E02-22B catalogue.

How to Order Solenoid Valves

- Standard**
- With switch**
- Individual wiring**
[for plug-in mixed mounting] Note)

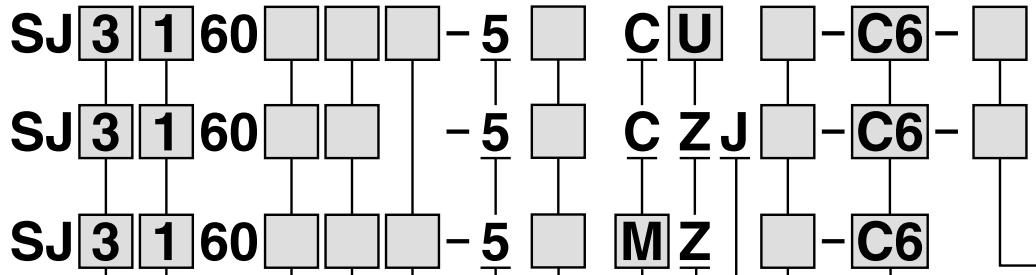

Note) Refer to pages 52 and 53 for the dedicated non-plug-in individual wiring.

Series

2	SJ2000
3	SJ3000

Pilot spec.

—	Internal pilot
R	External pilot

Note) External pilot spec. is not applicable for 4 position dual 3 port valves.

Back pressure check valve

—	None
K	Built-in

Note) Back pressure check valve is not applicable for 3 position valve.

Type of actuation

1	2 position single solenoid
2	2 position double solenoid
3	3 position closed centre
4	3 position exhaust centre
5	3 position pressure centre
A	Dual 3 port valve: N.C./N.C.
B	Dual 3 port valve: N.O./N.O.
C	Dual 3 port valve: N.C./N.O.

Coil spec.

—	Standard
T	With power saving circuit (continuous duty type)

Note) Be sure to select "with power saving circuit" when the solenoid valve will be energised continuously for long period.

Rated voltage

5	24 VDC
---	--------

Common spec.

-	Positive common
N	Negative common

Note 1) Select nothing for non polar type.
 Note 2) Be sure to match SI units common specifications

Note) Refer to pages 4 through to 7 for the JIS symbol.

Single solenoid wiring spec.

—	Single wiring
D	Double wiring

Note) There is no need to enter anything for 2 position double, 3 position and 4 position solenoid valves. Select this when the unused numbers to wiring are set. Refer to page 3 for details.

A, B port size

- Straight (Metric size)
- C2: ø2 one-touch fitting
 - C4: ø4 one-touch fitting
 - C6: ø6 one-touch fitting (SJ3000 only)
- (Inch size)
- N1: ø1/8" one-touch fitting
 - N3: ø5/32" one-touch fitting
 - N7: ø1/4" one-touch fitting (SJ3000 only)
- (Thread piping)
- M3: M3 x 0.5 (SJ2000 only)
 - M5: M5 x 0.8 (SJ3000 only)

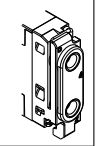
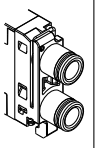

- Elbow fitting assembly (upward entry) (Metric size)
- L2: ø2 one-touch fitting
 - L4: ø4 one-touch fitting
 - L6: ø6 one-touch fitting (SJ3000 only)
- (Inch size)
- LN1: ø1/8" one-touch fitting
 - LN3: ø5/32" one-touch fitting
 - LN7: ø1/4" one-touch fitting (SJ3000 only)

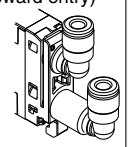

- Elbow fitting assembly (downward entry) (Metric size)
- B2: ø2 one-touch fitting
 - B4: ø4 one-touch fitting
 - B6: ø6 one-touch fitting (SJ3000 only)
- (Inch size)
- BN1: ø1/8" one-touch fitting
 - BN3: ø5/32" one-touch fitting
 - BN7: ø1/4" one-touch fitting (SJ3000 only)

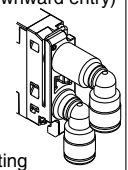

Connector entry

- C:** Dedicated for centralised wiring
- M:** Individual wiring, with lead wire Length 300 mm
- MN:** Individual wiring, without lead wire
- MO:** Individual wiring, without connector

Light/surge voltage suppressor

U	With light/surge voltage suppressor (non-polar type)
Z	With light/surge voltage suppressor (polar type)

Note 1) When the types with power saving circuit, with switches, and individual wiring are used, the non-polar type cannot be selected.

With switch

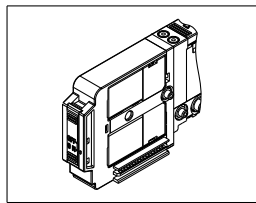

Manual override

- : Non-locking push type
- D: Push-turn locking slotted type

Note 1) Connector entries with the symbol "MC" can not use the switch signal from the common wiring on the manifold. For details, refer to "Connector Wiring Diagram" on page 3.
 Note 2) When ordering a connector assembly separately, refer to back page 8.

Series SJ2000/3000

Dimensions

SS5J2-60S6B □ D- Stations U- □

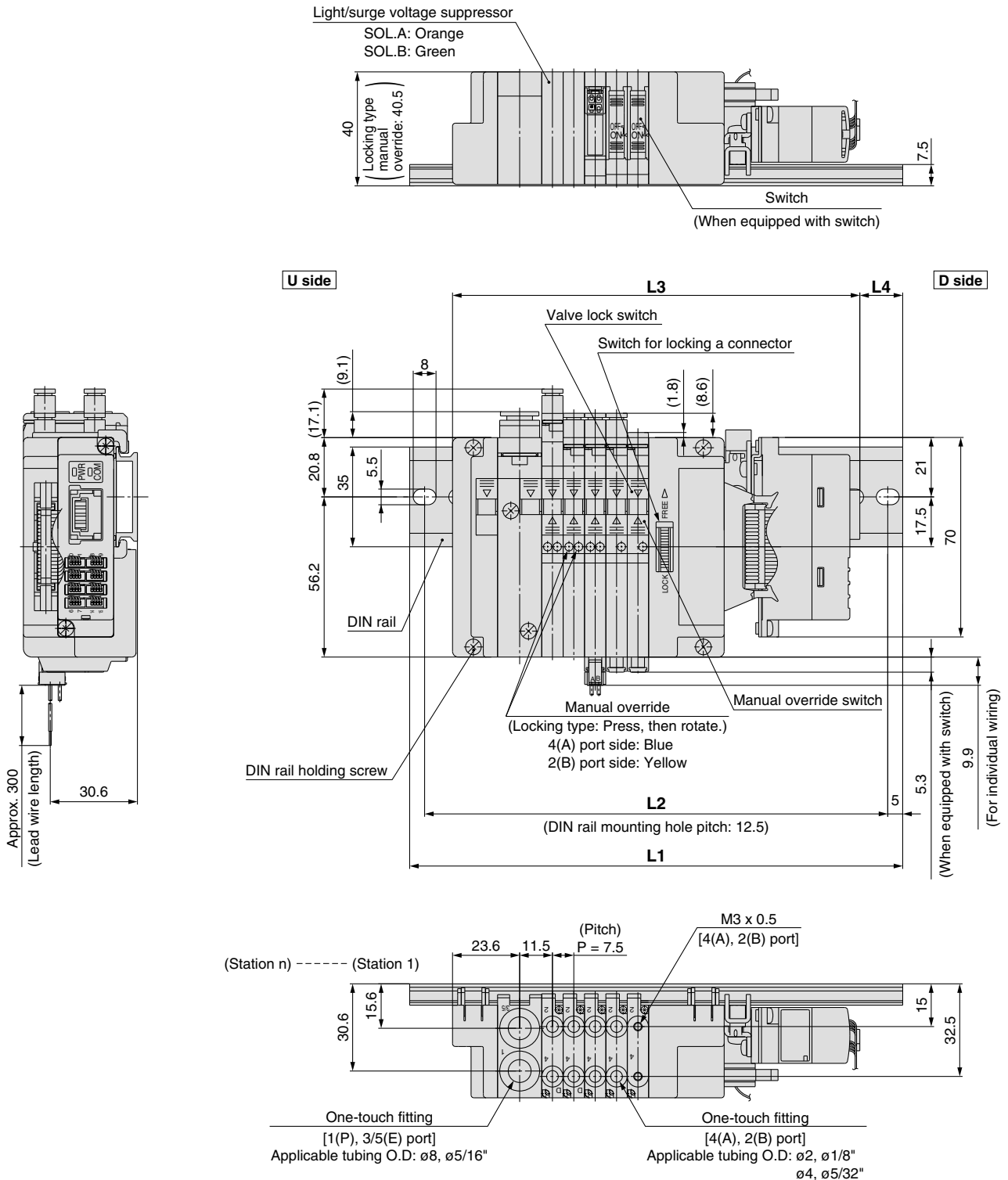

Note) Refer to page 36 for external pilot spec. and page 23 for elbow fitting manifold dimensions. Please contact SMC regarding the SI unit.

L: Dimensions

n: Stations

L \ n	2	3	4	5	6	7	8	9	10
L1	148	160.5	160.5	173	185.5	185.5	198	198	210.5
L2	137.5	150	150	162.5	175	175	187.5	187.5	200
L3	120.4	127.9	135.4	142.9	150.4	157.9	165.4	172.9	180.4
L4	14	16.5	12.5	15	17.5	14	16.5	12.5	15

Dimensions

SS5J2-60S6B □ D- Stations B- □

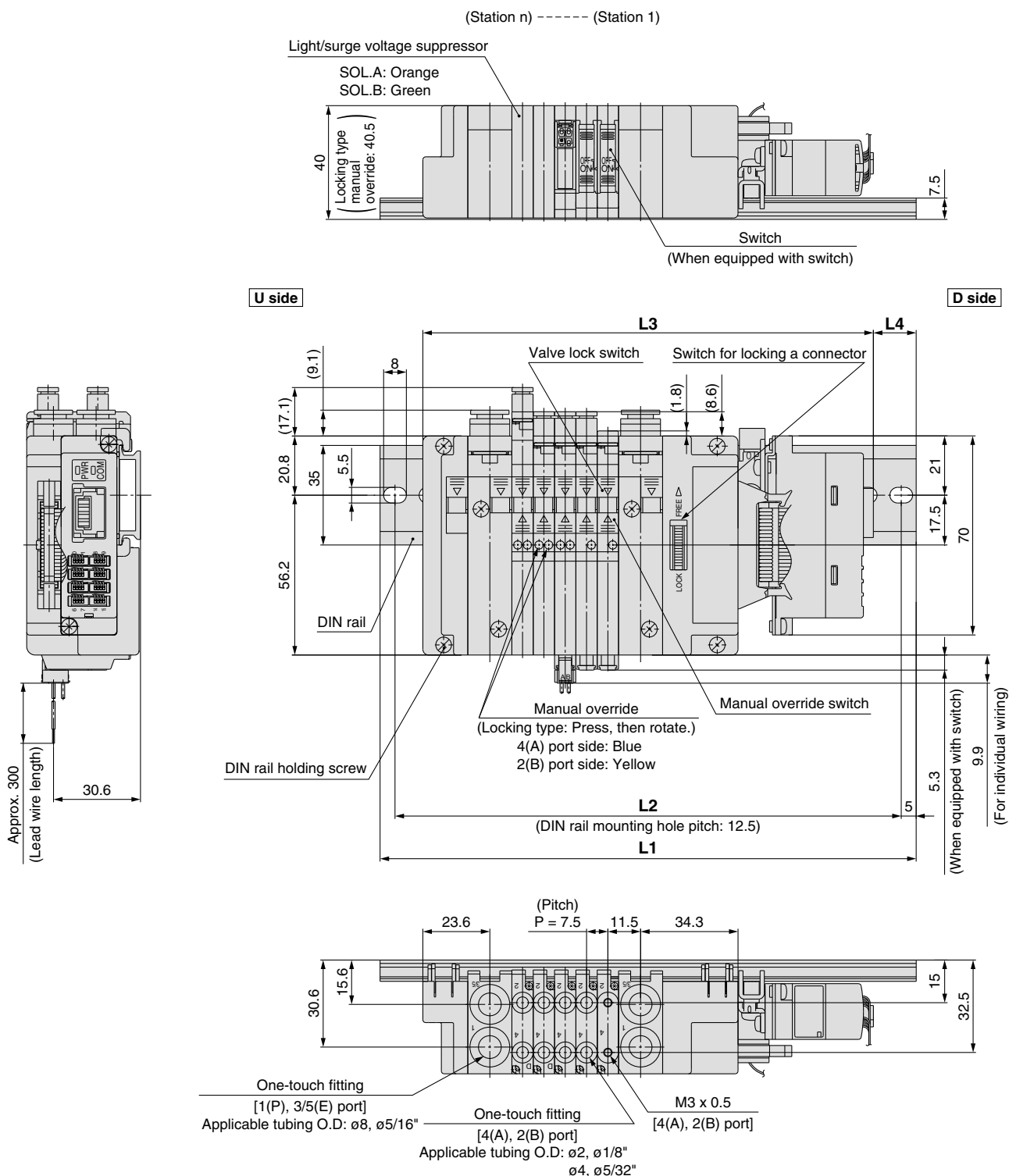

Note) Refer to page 37 for external pilot spec. and page 23 for elbow fitting manifold dimensions.
 Please contact SMC regarding the SI unit.

L: Dimensions

n: Stations

L \ n	2	3	4	5	6	7	8	9	10	11	12	13	14	15	16
L1	160.5	173	185.5	185.5	198	198	210.5	223	223	235.5	248	248	260.5	260.5	273
L2	150	162.5	175	175	187.5	187.5	200	212.5	212.5	225	237.5	237.5	250	250	262.5
L3	135.9	143.4	150.9	158.4	165.9	173.4	180.9	188.4	195.9	203.4	210.9	218.4	225.9	233.4	240.9
L4	12.5	15	17.5	13.5	16	12.5	15	17.5	13.5	16	18.5	15	17.5	13.5	16

Series SJ2000/3000

Dimensions

SS5J3-60S6B □ D- Stations U- □

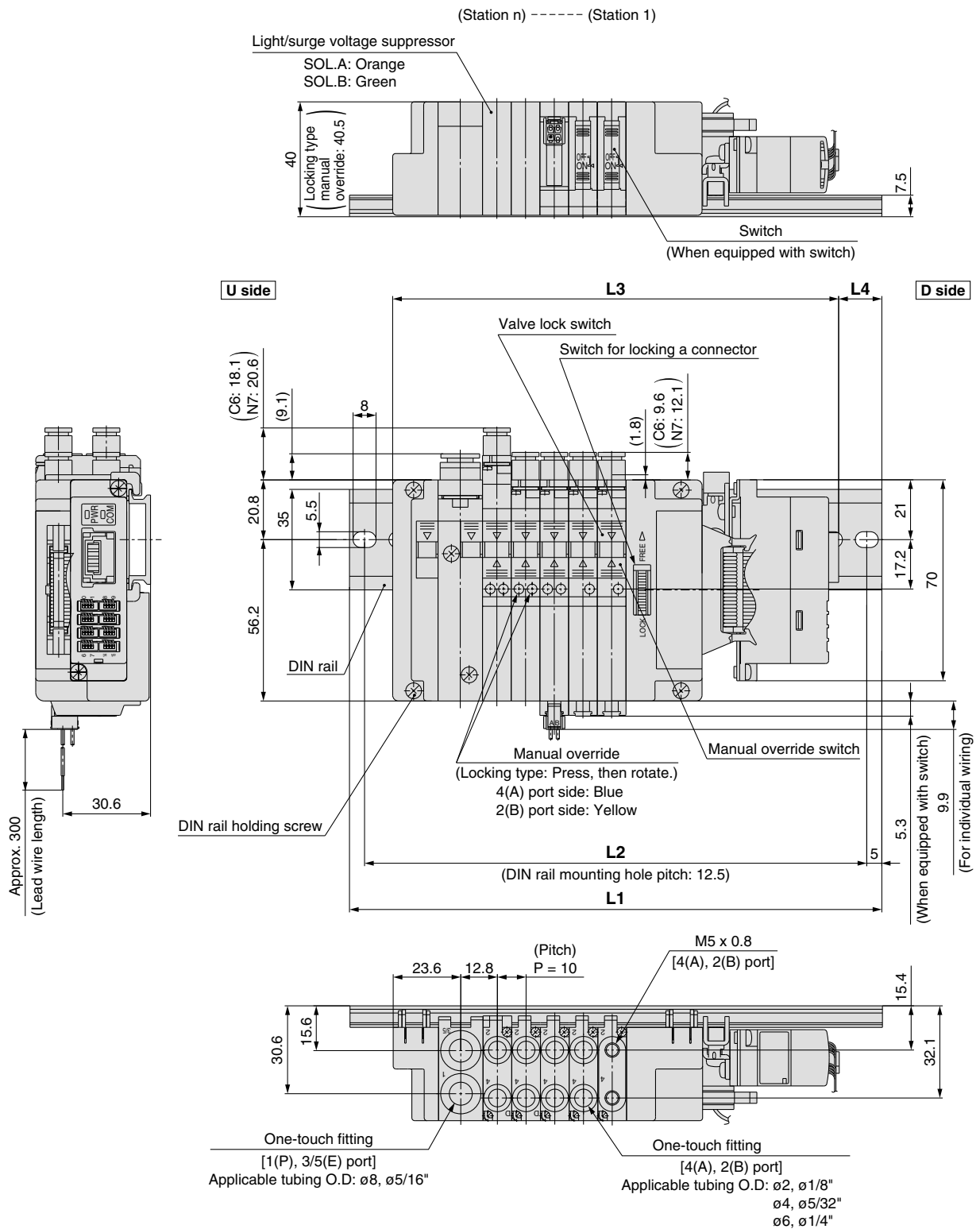

Note) Refer to page 38 for external pilot spec. and page 24 for elbow fitting manifold dimensions. Please contact SMC regarding the SI unit.

L: Dimensions

n: Stations

L \ n	2	3	4	5	6	7	8	9	10
L1	160.5	160.5	173	185.5	198	210.5	210.5	223	235.5
L2	150	150	162.5	175	187.5	200	200	212.5	225
L3	125.4	135.4	145.4	155.4	165.4	175.4	185.4	195.4	205.4
L4	17.5	12.5	14	15	16.5	17.5	12.5	14	15

Dimensions

SS5J3-60S6B □ D- Stations B- □

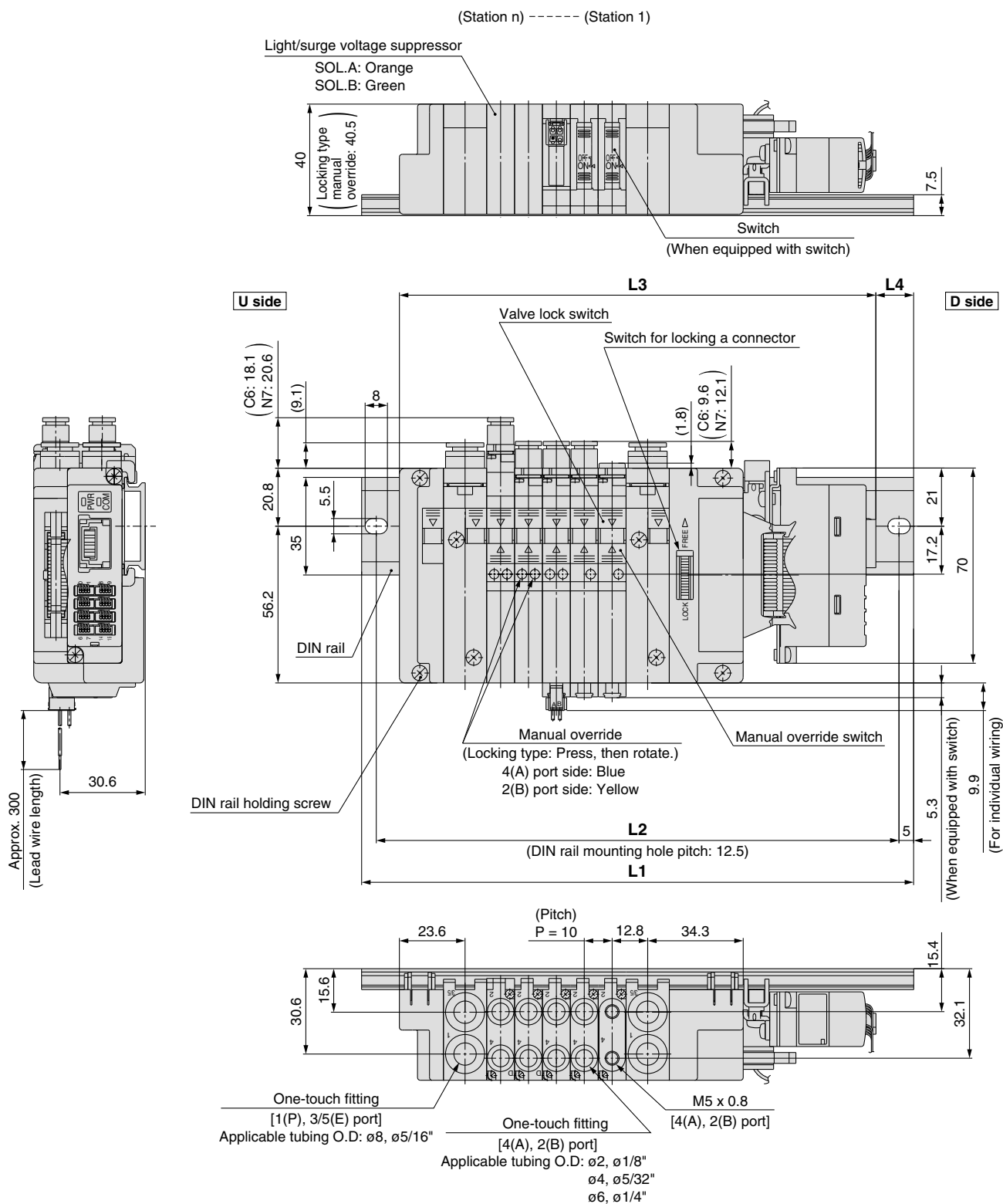

Note) Refer to page 39 for external pilot spec. and page 24 for elbow fitting manifold dimensions.
 Please contact SMC regarding the SI unit.

L: Dimensions

n: Stations

L \ n	2	3	4	5	6	7	8	9	10	11	12	13	14	15	16
L1	173	185.5	185.5	198	210.5	223	235.5	248	248	260.5	273	285.5	298	298	310.5
L2	162.5	175	175	187.5	200	212.5	225	237.5	237.5	250	262.5	275	287.5	287.5	300
L3	140.9	150.9	160.9	170.9	180.9	190.9	200.9	210.9	220.9	230.9	240.9	250.9	260.9	260.9	280.9
L4	16	17.5	12.5	13.5	15	16	17.5	18.5	13.5	15	16	17.5	18.5	18.5	15

Series SJ2000/3000

Dimensions: SJ2000/3000 Mixed Manifold

SS5J3-M60S6B□D-**Stations**U-□

L dimension: Formula, L1 to L4
 $L3 = 7.5 \times n1 + 10 \times n2 + 105.4$
 $M = (L3 + 4) / 12.5 + 1$
 Remove all numbers after the decimal.
 $L1 = M \times 12.5 + 23$
 $L2 = L1 - 10.5$
 $L4 = (L1 - L3) / 2 - 2$

n1: Piece of the SJ2000
 n2: Piece of the SJ3000

Note) The dimensions of L1 to L4 for **SS5J3-M60S6B□D-**Stations**D** are the same as those of **SS5J3-M60S6B□D-**Stations**U**.

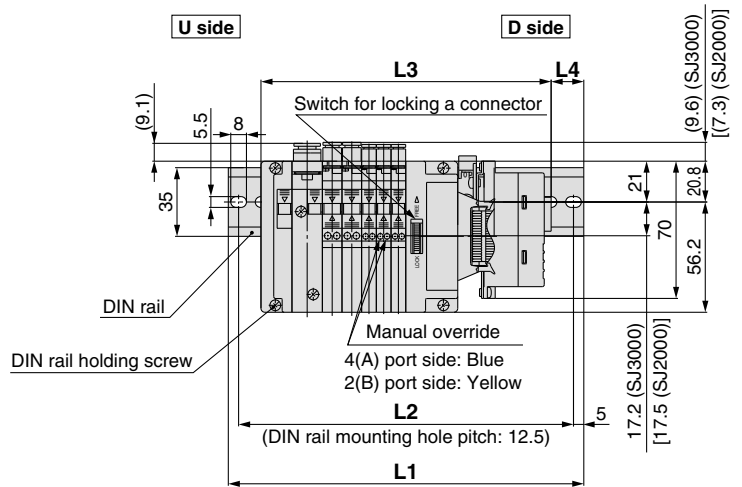
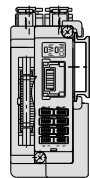
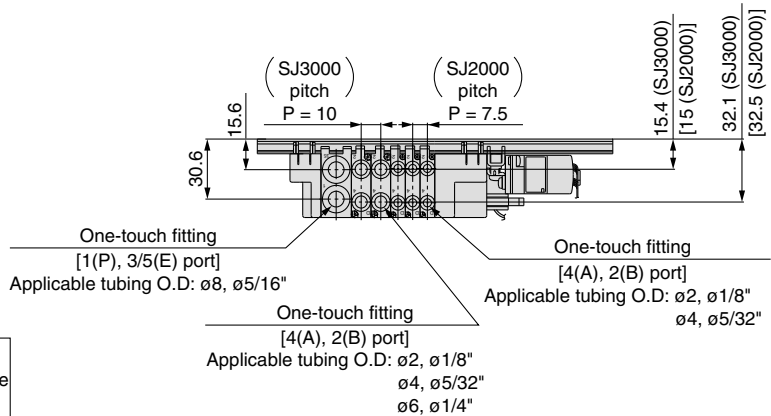

SS5J3-M60S6B□D-**Stations**B-□

L dimension: Formula, L1 to L4
 $L3 = 7.5 \times n1 + 10 \times n2 + 120.9$
 $M = (L3 + 4) / 12.5 + 1$
 Remove all numbers after the decimal.
 $L1 = M \times 12.5 + 23$
 $L2 = L1 - 10.5$
 $L4 = (L1 - L3) / 2 - 2$

n1: Piece of the SJ2000
 n2: Piece of the SJ3000

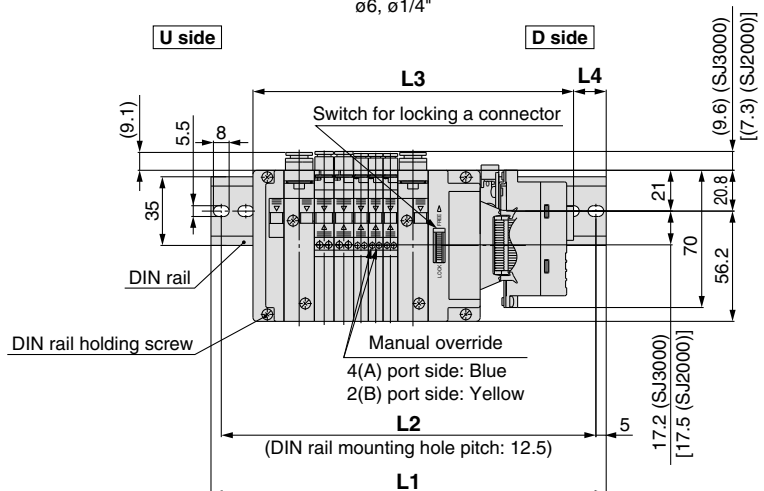
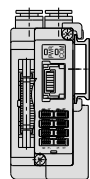
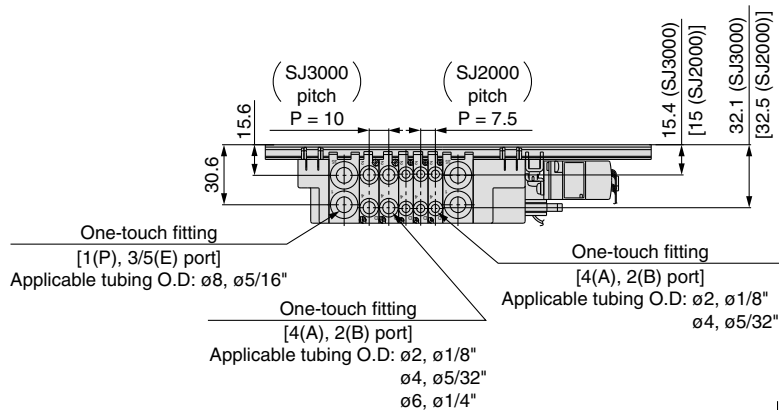

Manifold Exploded View

Type 60P (Flat ribbon cable) manifold

Type 60S (Plug-in, EX180 Serial wiring) manifold

Type 60G (Plug-in, PC wiring with power supply terminal) manifold

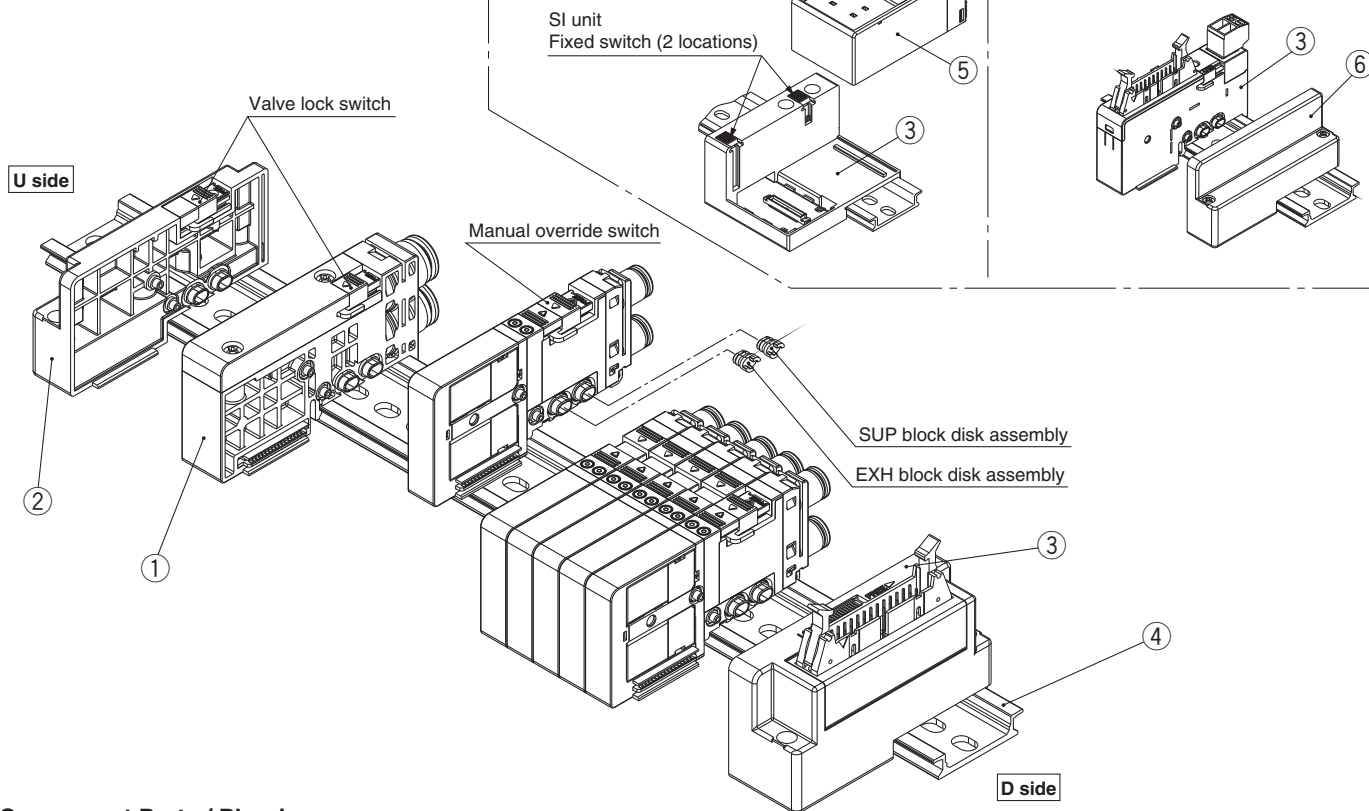

Component Parts / Plug-in

No.	Description	Part no.	Note
1	Internal pilot	SJ3000-50-1A-□□	(Metric size) C6: With ø6 one-touch fitting (straight) C8: With ø8 one-touch fitting (straight) L6: With ø6 one-touch fitting (elbow upward entry) L8: With ø8 one-touch fitting (elbow upward entry) B6: With ø6 one-touch fitting (elbow downward entry) B8: With ø8 one-touch fitting (elbow downward entry)
	Internal pilot / Built-in silencer	SJ3000-50-1AS-□□	
	External pilot	SJ3000-50-1AR-□□ (X, PE port: Metric size ø4 Inch size ø5/32")	
	External pilot / Built-in silencer	SJ3000-50-1ARS-□□ (X port: Metric size ø4 Inch size ø5/32")	
	For different pressures, internal pilot ^{Note 1)}	SJ3000-50-3A-□□	
	For different pressures ^{Note 1)} Internal pilot / Built-in silencer	SJ3000-50-3AS-□□	
2	End block assembly	SJ3000-53-1A	For U side
3	Connector block assembly	SJ3000-42-□A-□ SJ3000-76-2A-□	Refer to the connector block assembly part no. shown below
4	DIN rail	VZ1000-11-1-□	Refer to page 61
5	SI unit	EX180-□□	Refer to the SI unit part numbers on page 34
6	End block assembly	SJ3000-53-2A	For D side

Note 1) The valves cannot be operated only with the SUP/EXH block assembly for different pressure, select them in combination with the SUP/EXH block assembly for internal/external pilot.

Note 2) Refer to page 60 about the SUP/EXH block disk assembly and method of handling of parts at different pressures.

Connector Block Assembly Part No.

Connector specifications	Mounting position	Part no.	Note
For D-sub connector	D side	SJ3000-42-1A-□	□: 1 (connector upward) □: 2 (connector lateral)
For flat ribbon cable 26 pins		SJ3000-42-2A-□	
For flat ribbon cable 20 pins		SJ3000-42-3A-□	
For flat ribbon cable 10 pins		SJ3000-42-4A-□	
For PC wiring 20 pins		SJ3000-42-6A-□	
For EX180 serial wiring ^{Note)}		SJ3000-42-20A	
For PC wiring 20 pins with power supply terminal		SJ3000-76-2A-05	

Note) SI unit is not included.

Series SJ2000/3000

How to Add Manifold Stations

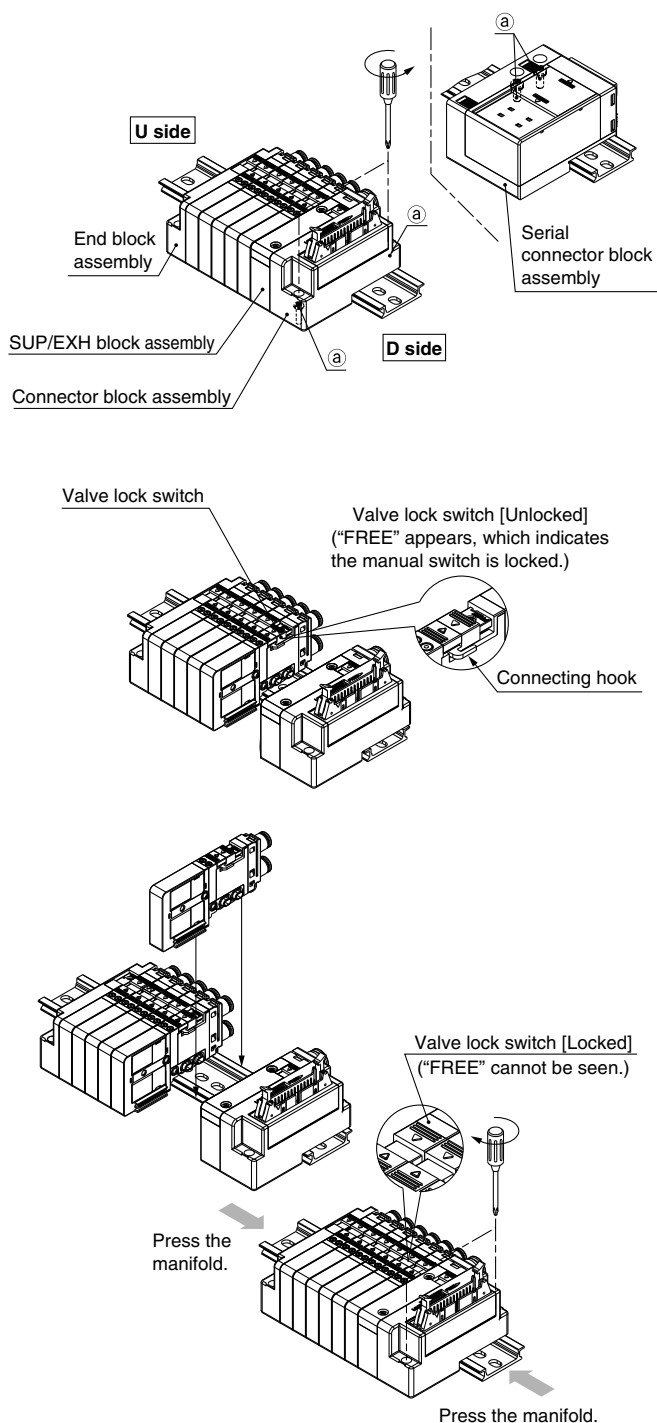

1 Loosen threads (a), which are fixed onto the DIN rail (two locations on one side).

2 In the direction of the coil, slide the valve where the additional valve station is desired to be added lock switch on each block.

(If blocks are removed without completely releasing the valve lock switch, the connection hook of that switch could be damaged or deformed.)

3 Install an additional valve or an SUP/EXH assembly on the DIN rail.

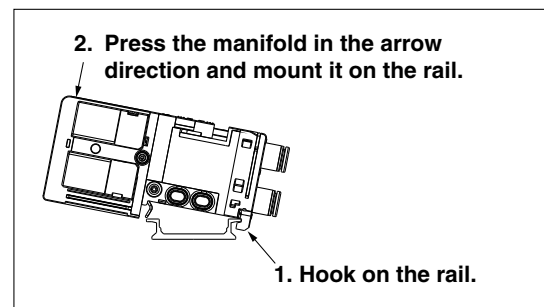

A manifold equipped with a valve or a block assembly can be mounted on the DIN rail. However, a serial connector block assembly cannot be mounted on the DIN rail when it is connected with another block; the serial connector block must be mounted separately.

4 Press the valves and block assemblies to each other for connection. Press the valve lock switch in the cylinder port direction until it does not go any further. Fasten threads (a) onto the DIN rail.

(After fixing the connector block assembly, fasten the screws on the end block assembly while holding it lightly by hand. This is necessary to improve sealing.)

Caution (D-sub, Connector block assembly for flat ribbon cable, End block assembly M3: 0.6 N·m
Connector block assembly for EX180 serial wiring M4: 1.4 N·m
Mounting bracket for EX510 serial wiring M4: 0.6 N·m)

Caution

- When increasing the number of stations from 10 or below to 11 or above, increase the number of SUP/EXH assemblies as well.
- Be sure to turn off the power and stop the supply of air before disassembly. Furthermore, since air may remain inside the actuator, piping and manifold, confirm that the air is completely exhausted before performing any work.
- After assembly and disassembly, air leakage could occur if the blocks are not well connected or if a thread is not tightly fastened onto the end block assembly. Before supplying air, make sure that no gaps exist in between blocks and that the valve and block are tightly fastened onto the DIN rail. Also, make sure that air is not leaking before use.
- For the SJ3A6 series manifold with vacuum release valve with restrictor, there is no valve lock switch for connecting, so tighten the screws after checking that there are no gaps between valves, when mounting.

**Non-plug-in
Individual Wiring Manifold**

Series SJ2000/3000

P.52 Individual Wiring



Non-plug-in Individual Wiring

Series SJ2000/3000



How to Order

● Individual wiring manifold

SS5J **3** - **60** - **05** **U** **□** **□** **□**

Series

2	SJ2000
3	SJ3000 (SJ2000/3000 mixed)

Mixed mounting type

—	Standard <small>Note 1)</small>
M	Mixed mounting <small>Note 2)</small>

Note 1) There is no need to enter anything when you order either the SJ2000 or SJ3000 series alone.

Note 2) Enter "M" when the SJ2000 or SJ3000 series will be mounted on the same manifold base together.

Valve stations

Symbol	Stations
02	2 stations
⋮	⋮
20	20 stations

DIN rail length specified

—	Standard length	
3	3 stations	Specify a longer rail than the standard length.
⋮	⋮	
20	20 stations	

Note) Specify the valve stations not exceeding the maximum stations.

SUP/EXH block fitting spec.

—	Straight fitting With external pilot spec. X, PE port	
L	Elbow fitting (upward) With external pilot spec. X, PE port	
B	Elbow fitting (downward) With external pilot spec. X, PE port	

Note) There is no need to enter anything when the SUP/EXH block mounting position "M" is selected.

Pilot spec.

—	Internal pilot
S	Internal pilot / Built-in silencer
R	External pilot
RS	External pilot / Built-in silencer

Note 1) There is no need to enter anything when the SUP/EXH block mounting position "M" is selected.
Note 2) For built-in silencers, the 3/5(E) ports are plugged.

SUP/EXH block mounting position

U	U side (2 to 10 stations)
D	D side (2 to 10 stations)
B	Both sides (2 to 20 stations)
M <small>Note)</small>	Special specifications

Note) Specify the required specifications (including port sizes other than ø8) by using a the manifold specification sheet.

How to Order Valve Manifold Assembly

Ordering example (SS5J3-60-□)

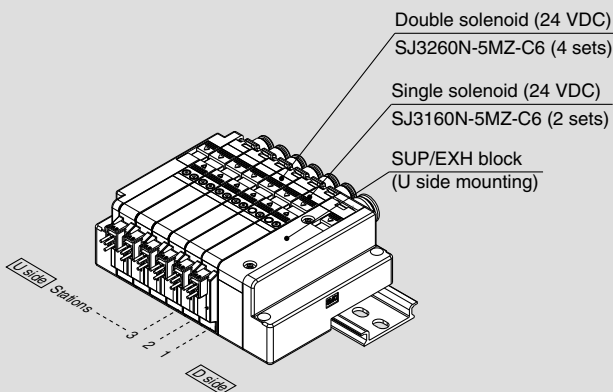

SS5J3-60-06D 1 set (Manifold part no.)
* SJ3160N-5MZ-C6 2 sets (Single solenoid part no.)
* SJ3260N-5MZ-C6 4 sets (Double solenoid part no.)

— The asterisk denotes the symbol for assembly.
Prefix to the part no. of the solenoid valve, etc.

- The valve arrangement is numbered as the 1st station from D side.
- Indicate the valves to be attached below the manifold part number, in order starting from station 1 as shown in the drawing.
- In the case of complex arrangement, specify them in the manifold specification sheet.

How to Order Solenoid Valves

SJ 3 1 60 [] [] [] N-5 [] M Z [] - C6

Series

2	SJ2000
3	SJ3000

Type of actuation

1	2 position single solenoid
2	2 position double solenoid
3	3 position closed centre
4	3 position exhaust centre
5	3 position pressure centre
A	Dual 3 port valve: N.C./N.C.
B	Dual 3 port valve: N.O./N.O.
C	Dual 3 port valve: N.C./N.O.

Note) Refer to pages 4 through to 7 for the JIS symbol.

Pilot spec.

-	Internal pilot
R	External pilot

Note) External pilot spec. is not applicable for 4 position dual 3 port valves.

Back pressure check valve

-	None
K	Built-in

Note) Back pressure check valve is not applicable for 3 position valve.

Coil spec.

-	Standard
T	With power saving circuit (continuous duty type)

Note) Be sure to select "with power saving circuit" when the solenoid valve will be energised continuously for long period.

Non-plug-in

Rated voltage

5	24 VDC
6	12 VDC

Common spec.

-	Positive common
N	Negative common

A, B port size

Straight (Metric size)
C2: ø2 one-touch fitting
C4: ø4 one-touch fitting
C6: ø6 one-touch fitting (SJ3000 only)

(Inch size)
N1: ø1/8" one-touch fitting
N3: ø5/32" one-touch fitting
N7: ø1/4" one-touch fitting (SJ3000 only)

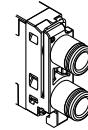

(Thread piping)
M3: M3 x 0.5 (SJ2000 only)
M5: M5 x 0.8 (SJ3000 only)

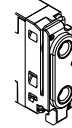

Elbow fitting assembly (upward entry) (Metric size)
L2: ø2 one-touch fitting
L4: ø4 one-touch fitting
L6: ø6 one-touch fitting (SJ3000 only)

(Inch size)
LN1: ø1/8" one-touch fitting
LN3: ø5/32" one-touch fitting
LN7: ø1/4" one-touch fitting (SJ3000 only)

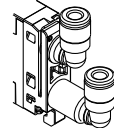

Elbow fitting assembly (downward entry) (Metric size)
B2: ø2 one-touch fitting
B4: ø4 one-touch fitting
B6: ø6 one-touch fitting (SJ3000 only)

(Inch size)
BN1: ø1/8" one-touch fitting
BN3: ø5/32" one-touch fitting
BN7: ø1/4" one-touch fitting (SJ3000 only)

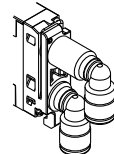

Connector entry

M: Individual wiring, with lead wire
 Length 300 mm

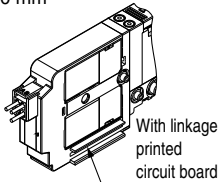

MN: Individual wiring, without lead wire (with connector, socket)

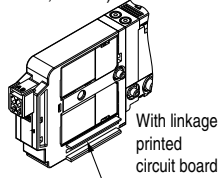

MO: Individual wiring, without connector

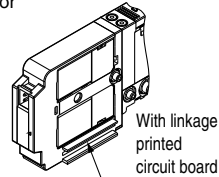

Note) When ordering a connector assembly separately, refer to back page 8.

With light/surge voltage suppressor

Manual override

-: Non-locking push type

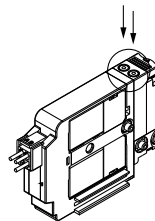

D: Push-turn locking slotted type

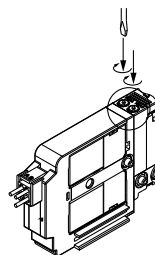

Series SJ2000/3000

Dimensions

SS5J2-60- Stations U (S, R, RS)

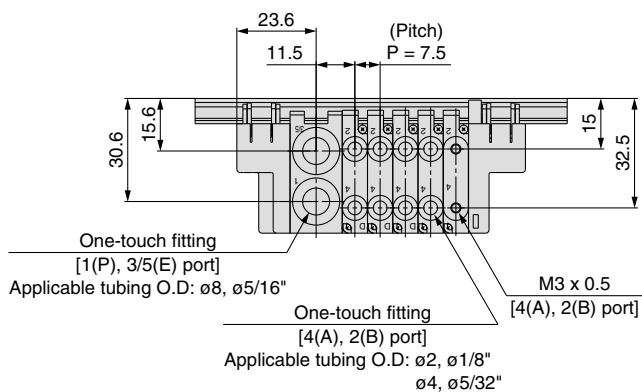
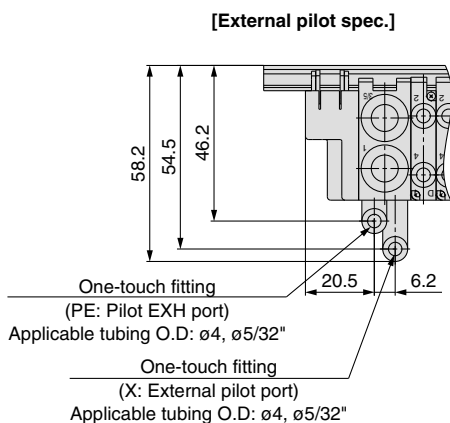
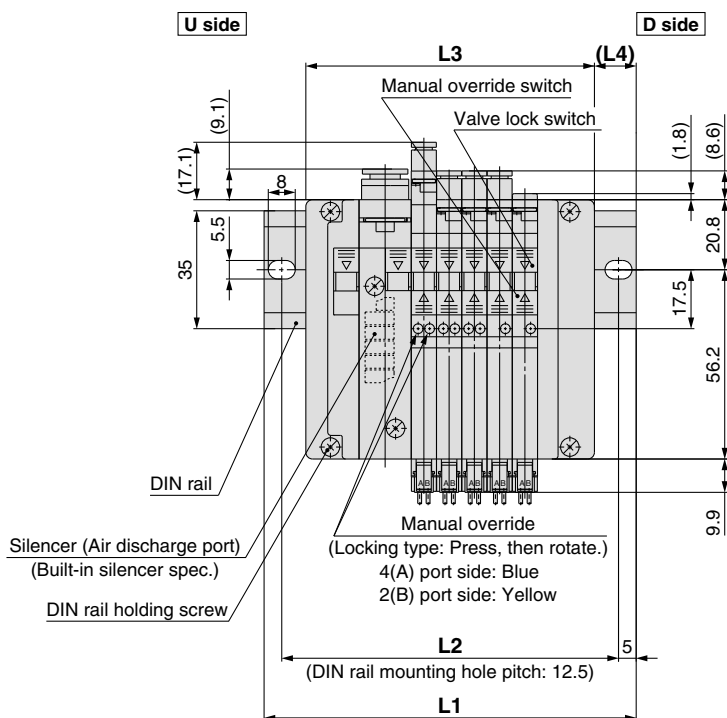
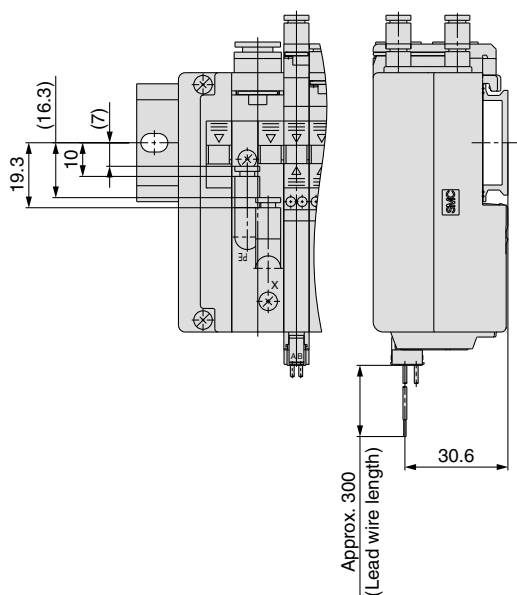
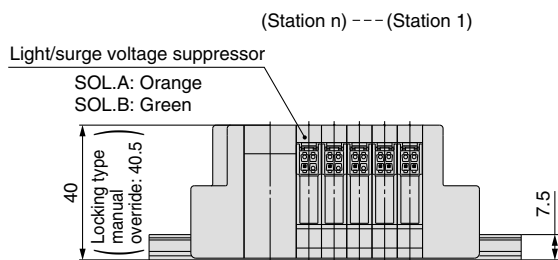

Note) For manifold dimensions including elbow fitting, refer to page 23.

L: Dimensions

n: Stations

L \ n	2	3	4	5	6	7	8	9	10
L1	98	98	110.5	110.5	123	135.5	135.5	148	148
L2	87.5	87.5	100	100	112.5	125	125	137.5	137.5
L3	63.2	70.7	78.2	85.7	93.2	100.7	108.2	115.7	123.2
L4	17.5	13.5	16	12.5	15	17.5	13.5	16	12.5

Dimensions

SS5J2-60- Stations B (S, R, RS)

(Station n) --- (Station 1)

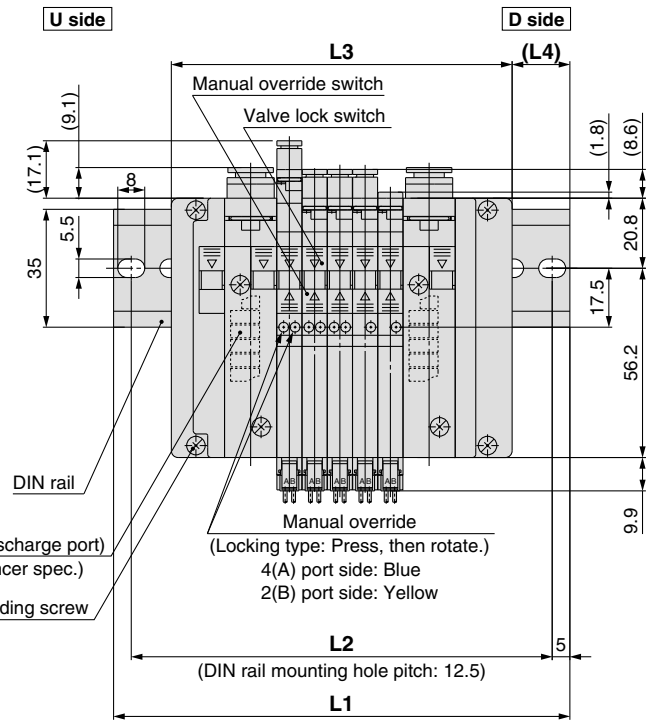
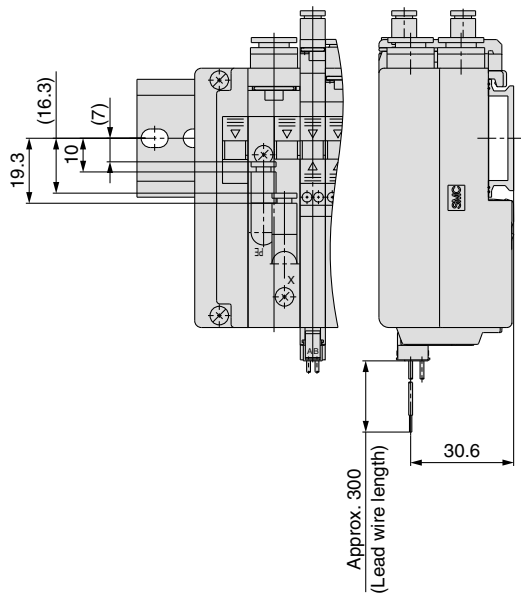
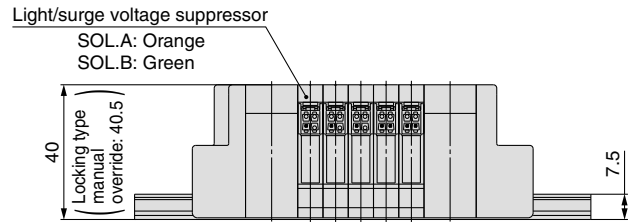

[External pilot spec.]

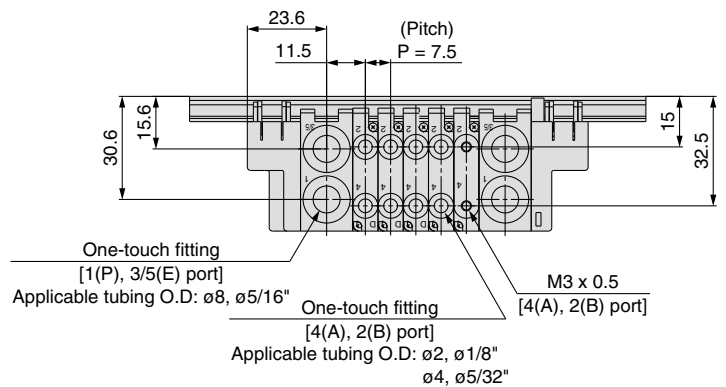
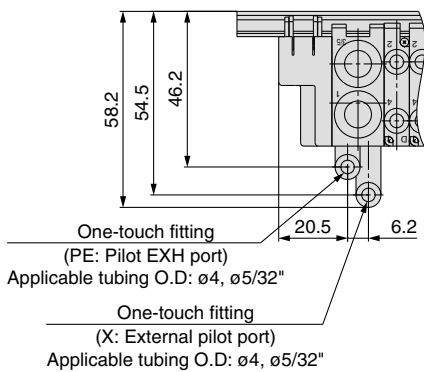

Note) For manifold dimensions including elbow fitting, refer to page 23.

L: Dimensions

n: Stations

L \ n	2	3	4	5	6	7	8	9	10	11	12	13	14	15	16	17	18	19	20
L1	110.5	110.5	123	135.5	135.5	148	148	160.5	173	173	185.5	185.5	198	210.5	210.5	223	223	235.5	248
L2	100	100	112.5	125	125	137.5	137.5	150	162.5	162.5	175	175	187.5	200	200	212.5	212.5	225	237.5
L3	78.7	86.2	93.7	101.2	108.7	116.2	123.7	131.2	138.7	146.2	153.7	161.2	168.7	176.2	183.7	191.2	198.7	206.2	213.7
L4	16	12	14.5	17	13.5	16	12	14.5	17	13.5	16	12	14.5	17	13.5	16	12	14.5	17

Series SJ2000/3000

Dimensions

SS5J3-60- Stations U (S, R, RS)

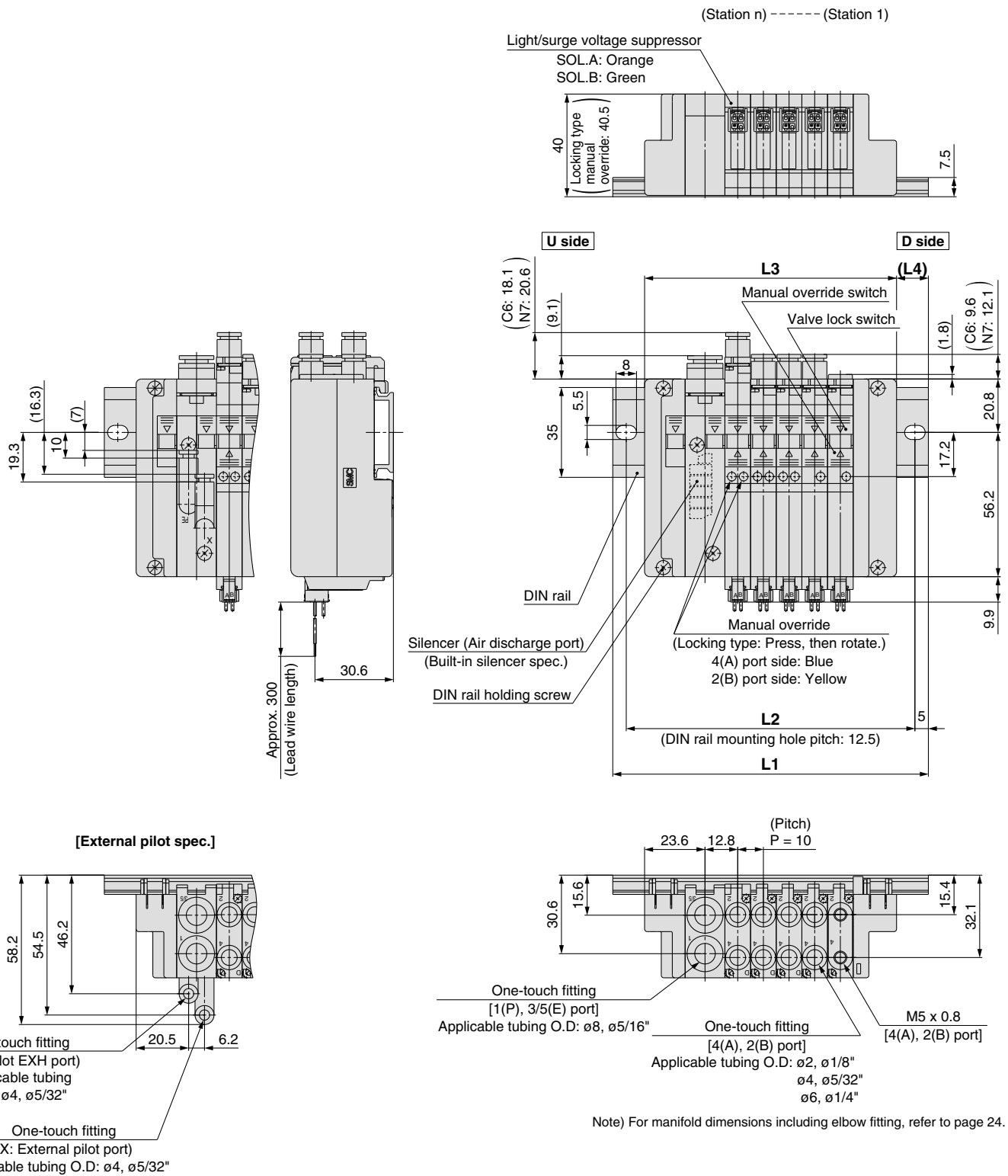

L: Dimensions

n: Stations

L \ n	2	3	4	5	6	7	8	9	10
L1	98	110.5	123	123	135.5	148	160.5	173	185.5
L2	87.5	100	112.5	112.5	125	137.5	150	162.5	175
L3	68.2	78.2	88.2	98.2	108.2	118.2	128.2	138.2	148.2
L4	14.5	16	17	12	13	14	15.5	16.5	17.5

Dimensions

SS5J3-60- Stations B (S, R, RS)

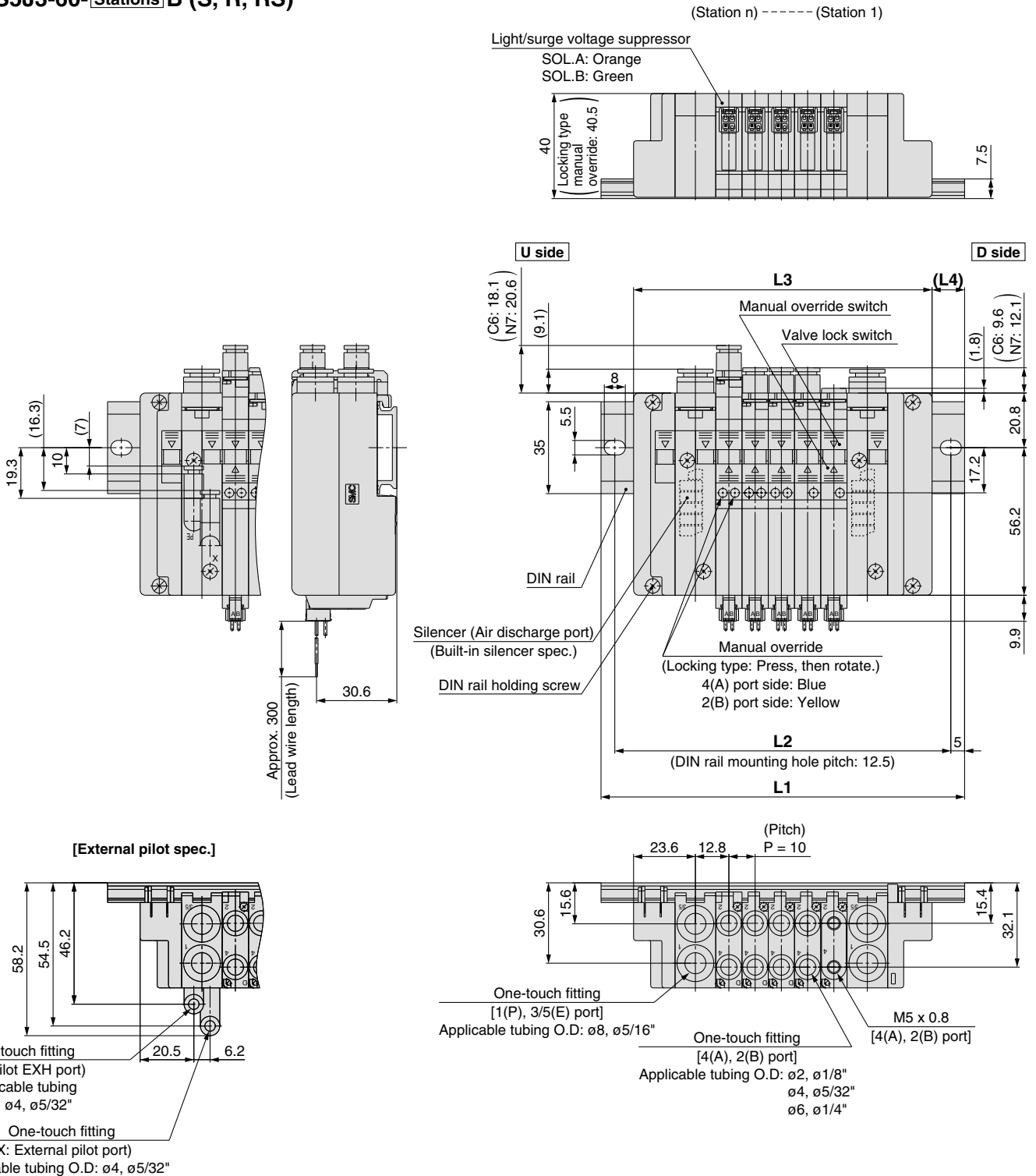

Note) For manifold dimensions including elbow fitting, refer to page 24.

L: Dimensions

		n: Stations																		
L \ n	2	3	4	5	6	7	8	9	10	11	12	13	14	15	16	17	18	19	20	
L1	110.5	123	135.5	148	148	160.5	173	185.5	198	210.5	210.5	223	235.5	248	260.5	260.5	273	285.5	298	
L2	100	112.5	125	137.5	137.5	150	162.5	175	187.5	200	200	212.5	225	237.5	250	250	262.5	275	287.5	
L3	83.7	93.7	103.7	113.7	123.7	133.7	143.7	153.7	163.7	173.7	183.7	193.7	203.7	213.7	223.7	233.7	243.7	253.7	263.7	
L4	13	14.5	15.5	16.5	11.5	12.5	14	15	16	17.5	12	13.5	14.5	15.5	17	11.5	13	14	15	

Series SJ2000/3000

Dimensions: SJ2000/3000 Mixed Manifold

SS5J3-M60-Stations U (S, R, RS)

L dimension: Formula, L1 to L4
 $L3 = 7.5 \times n1 + 10 \times n2 + 48.2$
 $M = (L3 + 4) / 12.5 + 1$
 Remove all numbers after the decimal.
 $L1 = M \times 12.5 + 23$
 $L2 = L1 - 10.5$
 $L4 = (L1 - L3) / 2 - 2$

n1: Piece of the SJ2000
 n2: Piece of the SJ3000

Note) The dimensions of L1 to L4 for
SS5J3-M60-StationsD are the same
 as those of **SS5J3-M60-StationsU**.

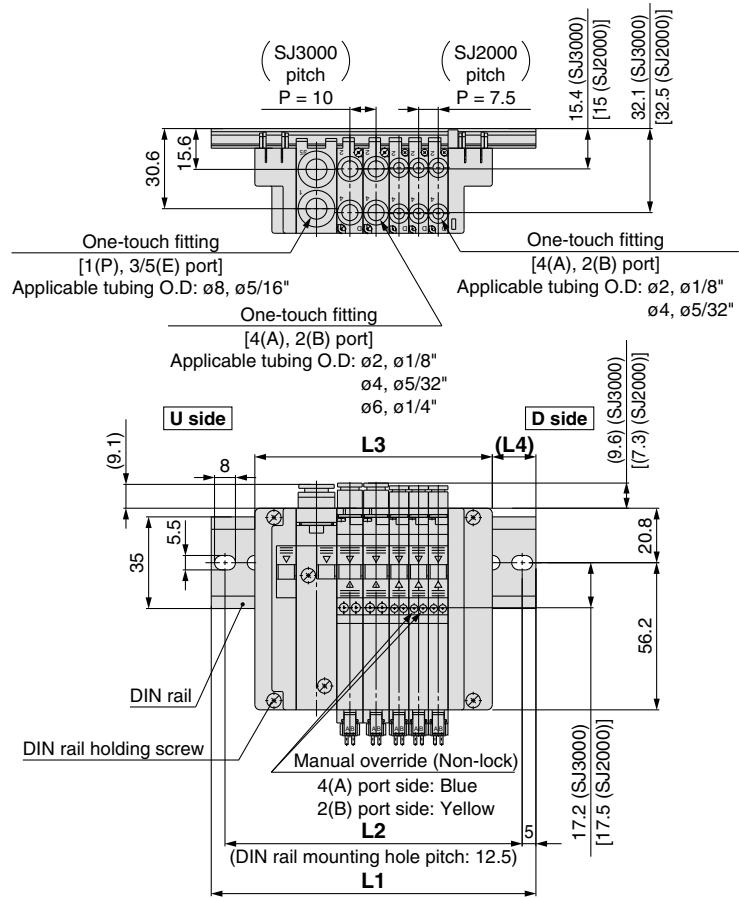
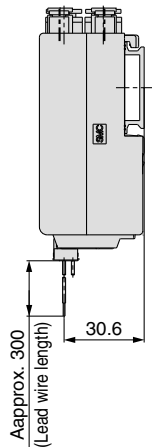

SS5J3-M60-Stations B (S, R, RS)

L dimension: Formula, L1 to L4
 $L3 = 7.5 \times n1 + 10 \times n2 + 63.7$
 $M = (L3 + 4) / 12.5 + 1$
 Remove all numbers after the decimal.
 $L1 = M \times 12.5 + 23$
 $L2 = L1 - 10.5$
 $L4 = (L1 - L3) / 2 - 2$

n1: Piece of the SJ2000
 n2: Piece of the SJ3000

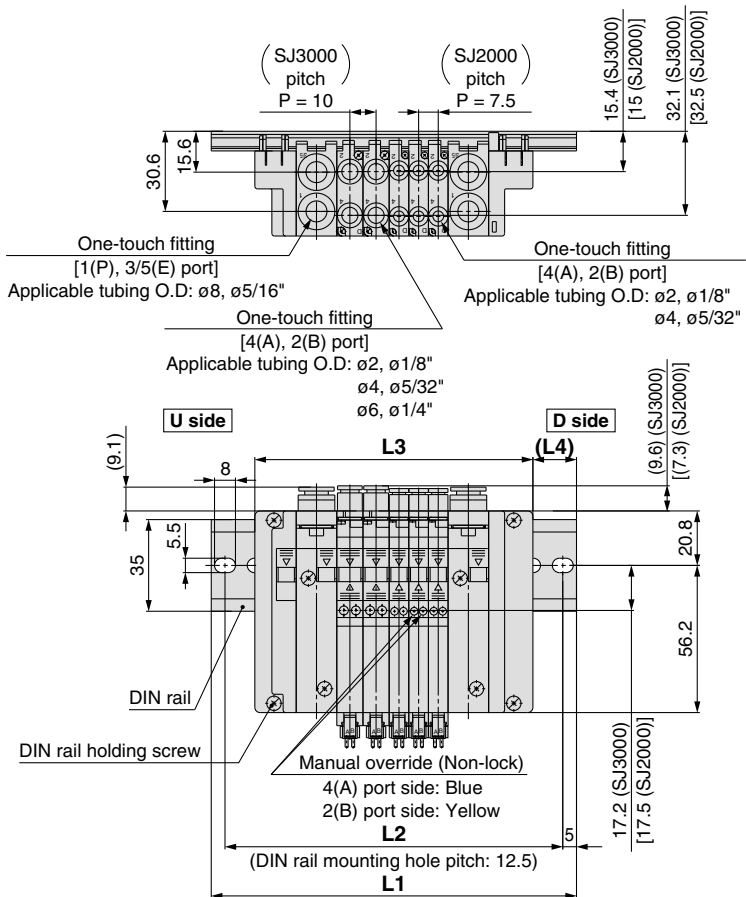
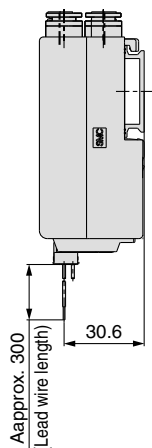

Manifold Exploded View

Type 60 (Non-plug-in) manifold

Note) Refer to page 50 for "How to Add Manifold Stations."

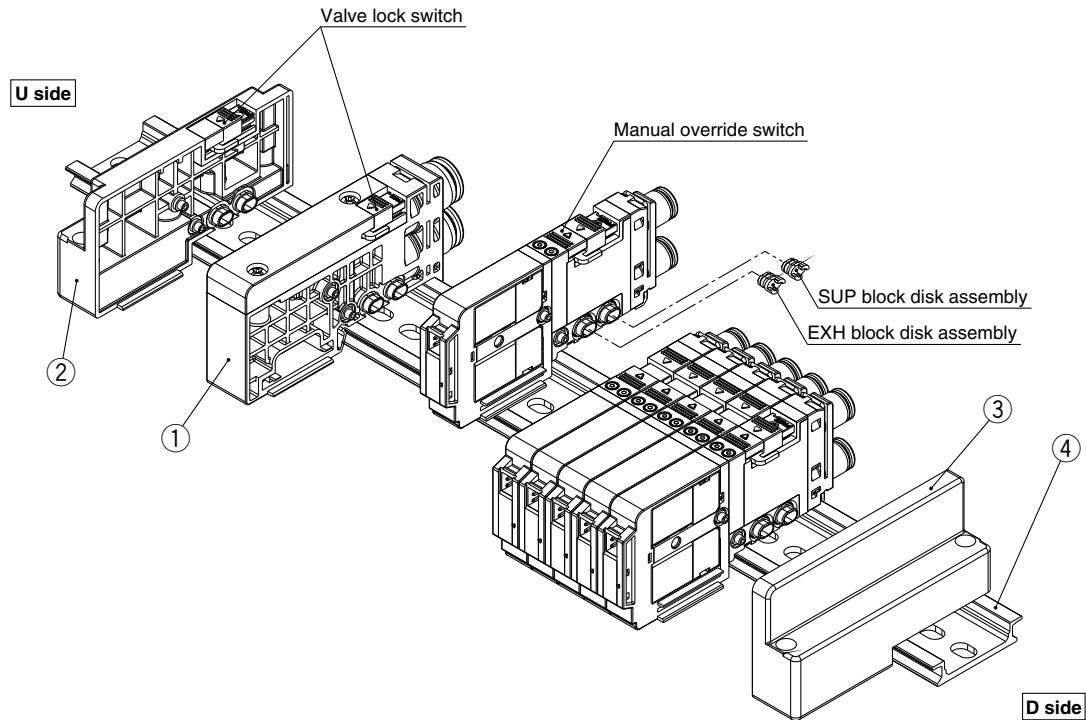

Component Parts / Non-plug-in

No.	Description	Part no.	Note
1	Internal pilot	SJ3000-50-5A-□□	(Metric size) C6: With ø6 one-touch fitting (straight) C8: With ø8 one-touch fitting (straight) L6: With ø6 one-touch fitting (elbow upward entry) L8: With ø8 one-touch fitting (elbow upward entry) B6: With ø6 one-touch fitting (elbow downward entry) B8: With ø8 one-touch fitting (elbow downward entry)
	Internal pilot / Built-in silencer	SJ3000-50-5AS-□□	
	External pilot	SJ3000-50-5AR-□□ (X, PE port: Metric size ø4 Inch size ø5/32"	
	External pilot / Built-in silencer	SJ3000-50-5ARS-□□ (X port: Metric size ø4 Inch size ø5/32"	
	For different pressures, internal pilot ^{Note 1)}	SJ3000-50-6A-□□	
	For different pressures ^{Note 1)} Internal pilot / Built-in silencer	SJ3000-50-6AS-□□	
2	End block assembly	SJ3000-53-1A	For U side
3	End block assembly	SJ3000-53-2A	For D side
4	DIN rail	VZ1000-11-1-□	Refer to page 61

Note 1) The valves cannot be operated only with the SUP/EXH block assembly for different pressure, select them in combination with the SUP/EXH block assembly for internal/external pilot.

Note 2) Refer to page 60 about the SUP/EXH block disk assembly and method of handling of parts at different pressure.

Series SJ2000/3000 Manifold Options

■ SUP block disk assembly

By placing a SUP block disk in a manifold valve's pressure supply passage, two different high and low pressures can be supplied to one manifold. When supplying different pressures using the manifold of the internal pilot, place an order by fill out a manifold specification sheet with a SUP/EXH assembly for internal pilot specifications and SUP/EXH block assembly for the different-pressure internal pilot specifications (Refer to Circuit Diagram 1).

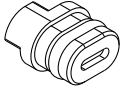

Series	Part no.
SJ2000	SJ3000-44-1A
SJ3000	

[Different pressure pneumatic circuit diagram]

SJ series supplies air to the pilot port of each valve using a 1(P) port of the SUP/EXH block assembly. When using in situations such as where there are different pressures, combine SUP/EXH block assemblies for internal pilot, external pilot and different-pressure by referring to the circuit below.

1. Different-pressure spec. using the internal pilot:

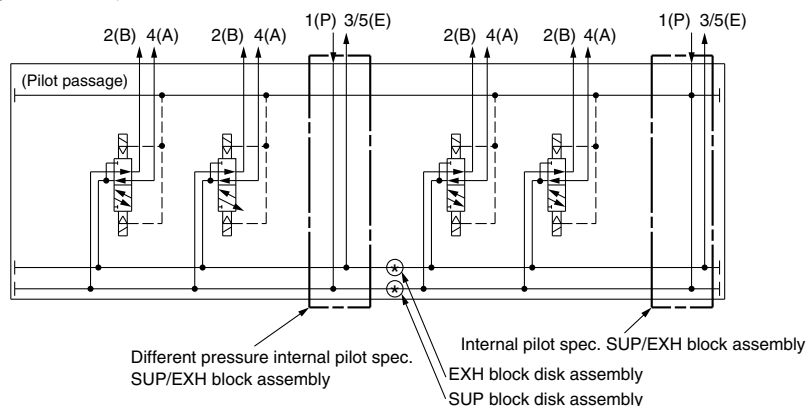

2. Different-pressure spec. using the external pilot:

(For using the SUP/EXH block assembly for external pilot)

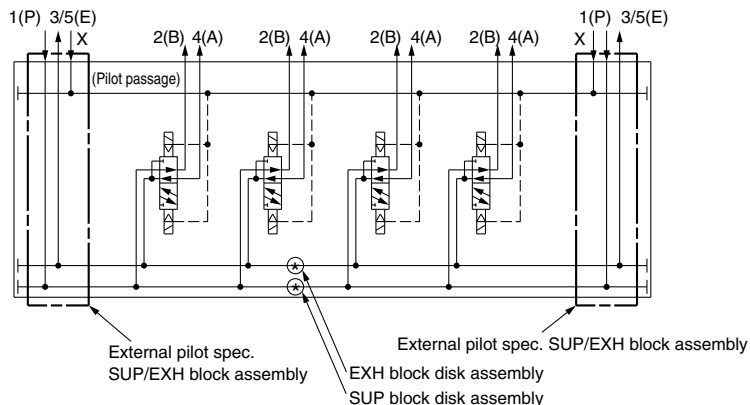

3. Different-pressure spec. using the external pilot:

(For using the SUP/EXH block assembly for different-pressure internal pilot spec.)

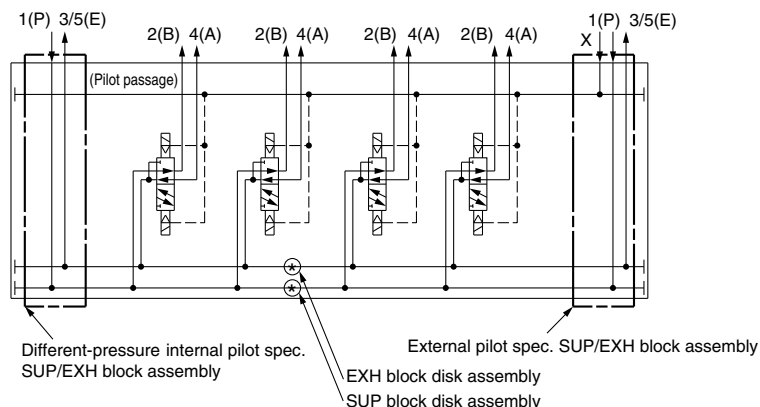

Note 1) When operating under the different-pressure spec., supply the higher pressure to the pilot passage.

Note 2) If there is a need to partition the pilot passage, consult SMC.

4 Port Solenoid Valve *Series SJ2000/3000*

■ EXH block disk assembly

By installing an EXH block disk in a manifold valve's exhaust passage, the valve's exhaust can be separated so that it will not affect other valves.

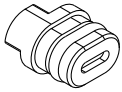

Series	Part no.
SJ2000	SJ3000-44-1A
SJ3000	

■ Label for block disk

These labels are attached to manifolds in which SUP and EXH block disks have been installed, in order to identify the installed locations. (Three sheets each included.)

SJ3000-155-1A

Label for
SUP/EXH block disk

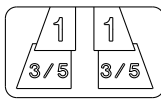

Label for
SUP block disk

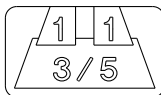

Label for
EXH block disk

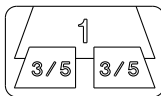

Note) When a block disk is concurrently ordered by specifying it on the manifold specification sheet, etc., a label will be stuck on the position where block disk is mounted.

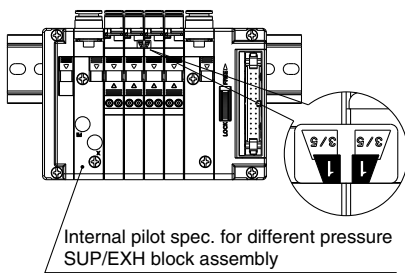

■ Blanking block assembly

It is mounted when, for example, later addition of valves is planned.

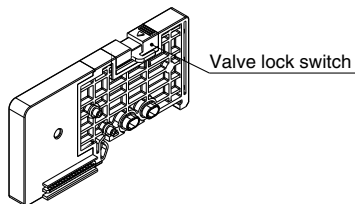

Series	Part no.	Note	Width
SJ2000	SJ3000-49-1A	Single wiring	7.5 mm
SJ3000	SJ3000-49-2A	Double wiring	
SJ3A6	SJ3000-49-2A-N	Double wiring (Note)	

Note) Valve lock switch is not available for the SJ3A6.

■ Silencer with one-touch fitting

This silencer can be mounted on the manifolds' port 3/5 (E: Exhaust) with a single touch.

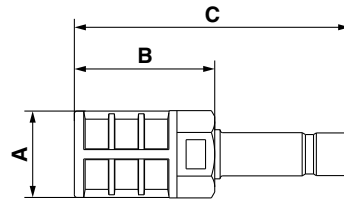

Series	Model	Effective area	A	B	C
For SJ2000 SJ3000 (ø8)	AN203-KM8	14 mm ²	ø16	26	51

■ Plug

These are inserted in unused cylinder ports and P, E ports.

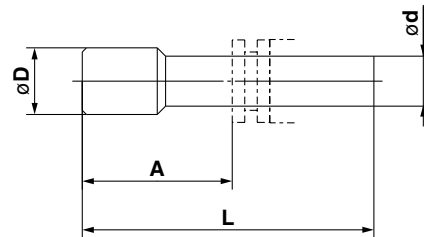

Dimensions

Applicable fitting size ød	Model	A	L	D
2	KJP-02	8.2	17	3
4	KQ2P-04	16	32	6
6	KQ2P-06	18	35	8
8	KQ2P-08	20.5	39	10
1/8"	KQ2P-01	16	31.5	5
5/32"	KQ2P-03	16	32	6
1/4"	KQ2P-07	18	35	8.5
5/16"	KQ2P-09	20.5	39	10

■ DIN rail

VZ1000-11-1-

• L dimension

Note) Enter a number from the DIN rail dimension table shown below.

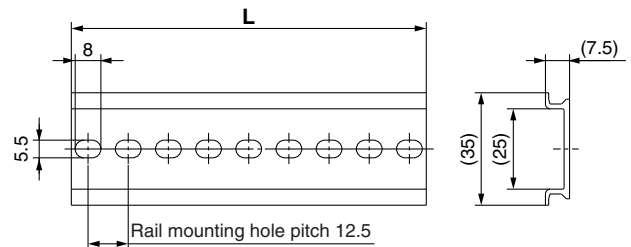

No.	0	1	2	3	4	5	6	7	8	9
L dimension	98	110.5	123	135.5	148	160.5	173	185.5	198	210.5
Weight (g)	17.6	19.9	22.1	24.4	26.6	28.9	31.1	33.4	35.6	37.9

No.	10	11	12	13	14	15	16	17	18	19
L dimension	223	235.5	248	260.5	273	285.5	298	310.5	323	335.5
Weight (g)	40.1	42.4	44.6	46.9	49.1	51.4	53.6	55.9	58.1	60.4

No.	20	21	22	23	24	25	26	27	28	29
L dimension	348	360.5	373	385.5	398	410.5	423	435.5	448	460.5
Weight (g)	62.6	64.9	67.1	69.4	71.6	73.9	76.1	78.4	80.6	82.9

Series SJ2000/3000

Flat ribbon cable assembly

AXT100-FC□¹₂₃

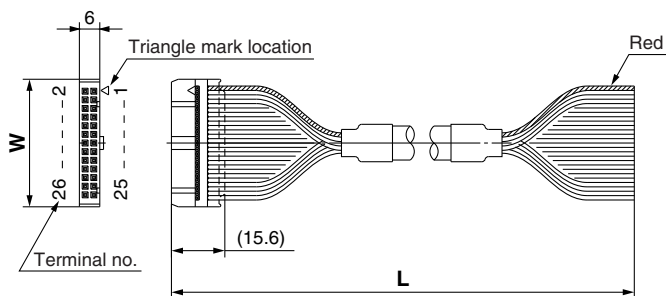

Flat Ribbon Cable Assembly

Cable length (L)	10 pins	20 pins	26 pins
1.5 m	AXT100-FC10-1	AXT100-FC20-1	AXT100-FC26-1
3 m	AXT100-FC10-2	AXT100-FC20-2	AXT100-FC26-2
5 m	AXT100-FC10-3	AXT100-FC20-3	AXT100-FC26-3
Connector width (W)	17.2	30	37.5

Note) For other commercial connectors, use a type with strain relief that conforms to MIL-C-83503.

Connector manufacturers:

- Hirose Electric Co., Ltd.
- Sumitomo 3M Limited
- Fujitsu Limited
- Japan Aviation Electronics Industry, Ltd.
- J.S.T. Mfg. Co., Ltd.

D-sub connector (25 pins)/Cable assembly

AXT100-DS25-⁰¹⁵₀₃₀₀₅₀

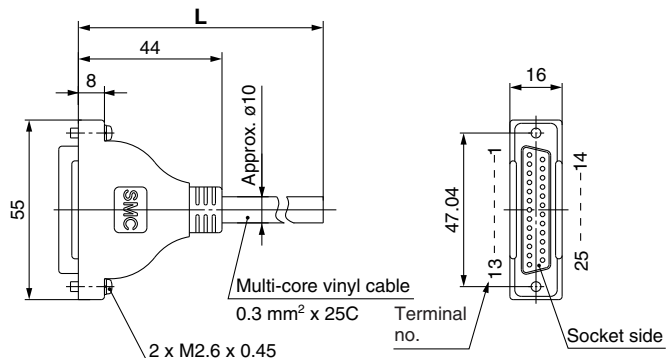

D-sub Connector Cable Assembly

Cable Colour List of Each Terminal No.

Terminal no.	Lead wire colour	Dot marking
1	Black	—
2	Brown	—
3	Red	—
4	Orange	—
5	Yellow	—
6	Pink	—
7	Blue	—
8	Purple	White
9	Gray	Black
10	White	Black
11	White	Red
12	Yellow	Red
13	Orange	Red
14	Yellow	Black
15	Pink	Black
16	Blue	White
17	Purple	—
18	Gray	—
19	Orange	Black
20	Red	White
21	Brown	White
22	Pink	Red
23	Gray	Red
24	Black	White
25	White	—

D-sub Connector Cable Assembly

Cable length (L)	Assembly part no.	Note
1.5 m	AXT100-DS25-015	Cable 25 cores x 24AWG
3 m	AXT100-DS25-030	
5 m	AXT100-DS25-050	

Note) For other commercial connectors, use a 25 pins type with female connector conforming to MIL-C-24308.

Electric Characteristics

Item	Characteristics
Conductor resistance Ω/km, 20°C	65 or less
Withstand pressure V, 1 min, AC	1000
Insulation resistance MΩkm, 20°C	5 or less

Note) The minimum bending radius for D-sub connector cables is 20 mm.

Connector manufacturers:

- Hirose Electric Co., Ltd.
- Fujitsu Limited
- Japan Aviation Electronics Industry, Ltd.
- J.S.T. Mfg. Co., Ltd.

4 Port Solenoid Valve Series SJ2000/3000

Regulator block

How to Order Regulator Block

Block used to reduce the pressure supplied from the D side inside the manifold.
All valves on the U side are depressurized from the regulator block.

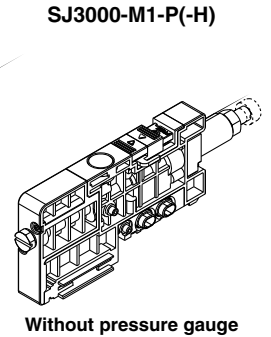
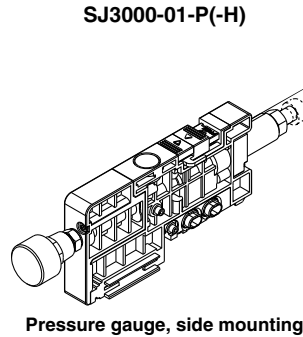
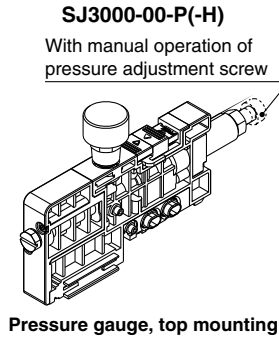
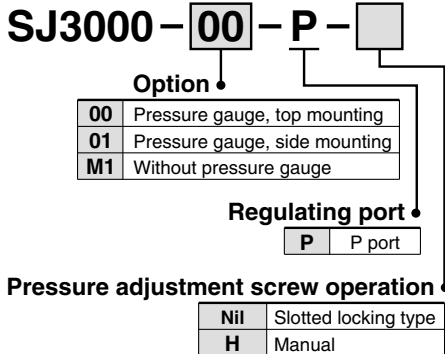

Note) When ordering with a regulator block installed in the manifold, please use the manifold specification sheet.

Flow Characteristics (Conditions: Inlet pressure 0.7 MPa, 2 position solenoid valve mounting)

SJ3000

P port regulation (P→A, B)

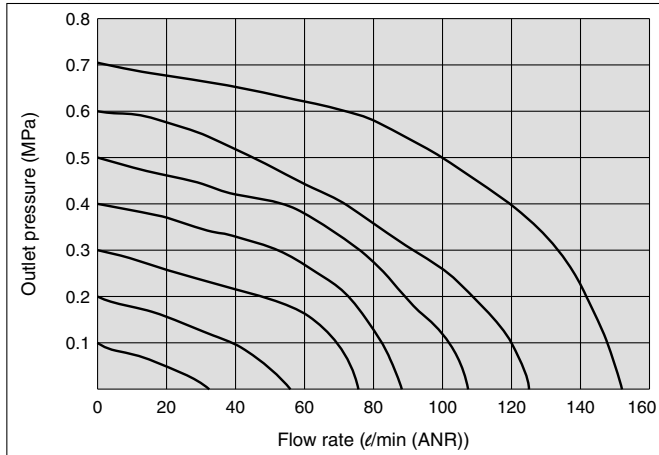

SJ2000

P port regulation (P→A, B)

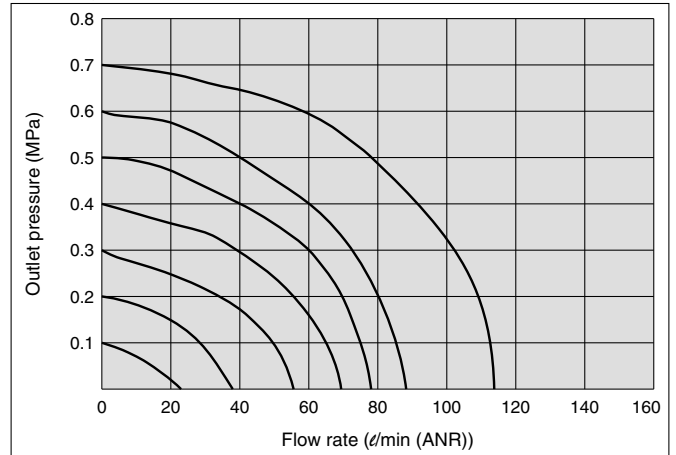

Pneumatic circuit (Regulator block mounting example)

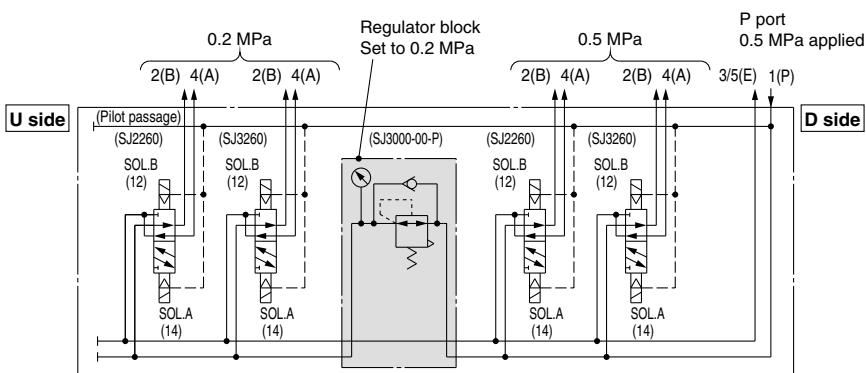

Note) Reduces supply pressure from the D side of manifold.
Supply pressure from the U side cannot be reduced.

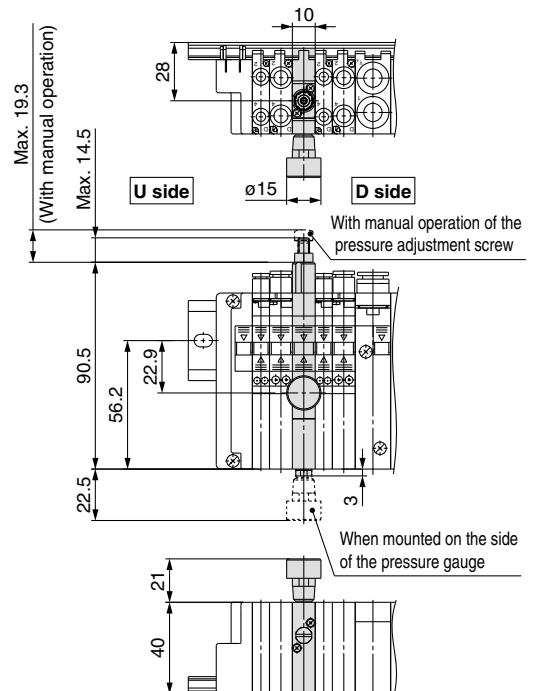

Series SJ2000/3000

Intermediate connector block assembly

This connector block is inserted into the middle of the manifold.
This can be used, for example, to separate electrical control of valves in the same manifold, or when the number of control points is insufficient.

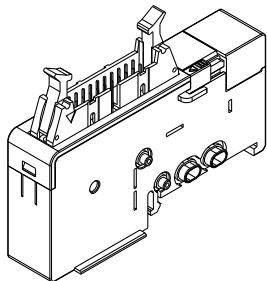

Series	Part no.	Note
SJ2000	SJ3000-76-1A	
SJ3000	SJ3000-76-2A-05	With power supply terminal (for PC wiring)

Note) When ordering with an intermediate connector block assembly installed in the manifold, please use a manifold specification sheet.

Intermediate connector block assembly wiring example

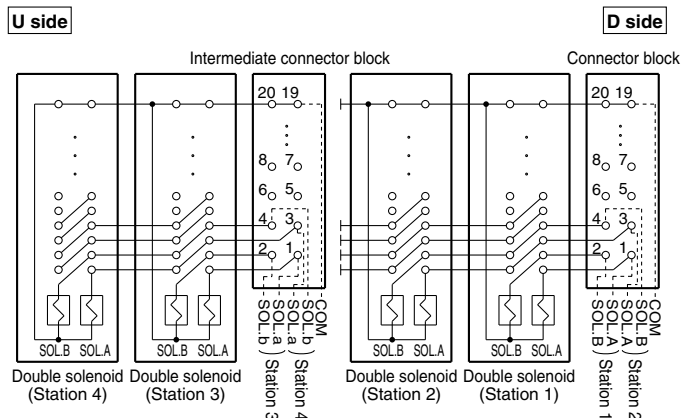

Note) Enables control of U side solenoid valves from the position where the intermediate connector block assembly is installed.

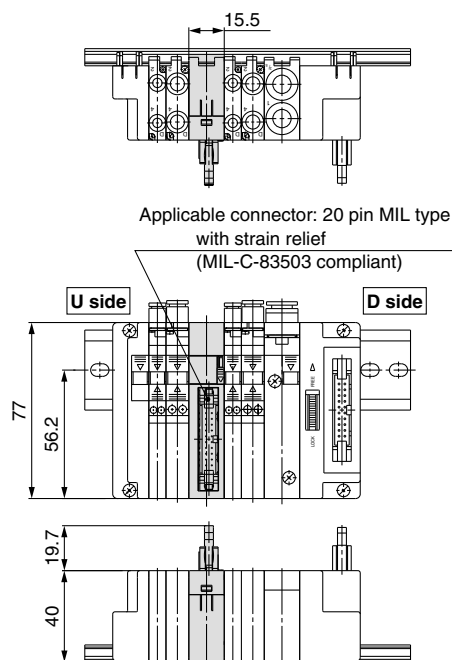

Dual flow fitting (Set for SJ3000 series)

SJ3000-120-1A-C8

Port size	
C8	ø8
N9	ø5/16"

It is a fitting for cylinder ports which enables simultaneous actuation and increase in flow rate of valves for 2 stations. It is a one-touch fitting with port sizes of ø8 and ø5/16.

Note) When arranging mounted to the valve, order the valve part no. using the part no. without the one-touch fitting, and then add the part no. for the dual flow fitting. If the arrangement is complicated, please specify it by using a manifold specification sheet.

Example: Valve type (without one-touch fitting)

SJ3160-5CU-CO 2 sets

* **SJ3000-120-1A-C8** 1 set

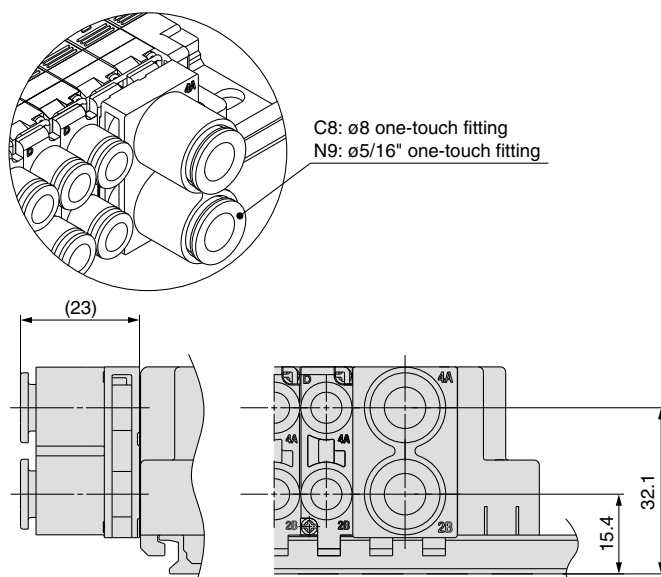

Series SJ2000/3000

Made to Order



1 Main Valve Fluoro Rubber Specifications Symbol -X90

Fluoro rubber is used for rubber parts of the main valve to allow use in applications such as the following.

1. When using a lubricant other than the recommended turbine oil, and there is a possibility of malfunction due to swelling of the spool valve seals.
2. When ozone enters or is generated in the air supply.

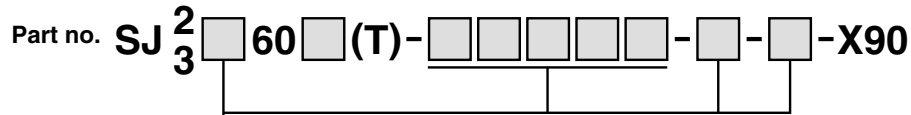

• Entry is the same as standard products.

Note) Because in series -X90 fluoro rubber is only used for the main valve, the rubber parts of the application/usage in conditions requiring heat resistance should be avoided.

Vacuum Release Valve with Restrictor

Series SJ3A6

Plug-in Type Connector Connection

P.70

D-sub Connector
Flat Ribbon Cable
PC Wiring
Serial Wiring: EX180
Serial Wiring: EX510

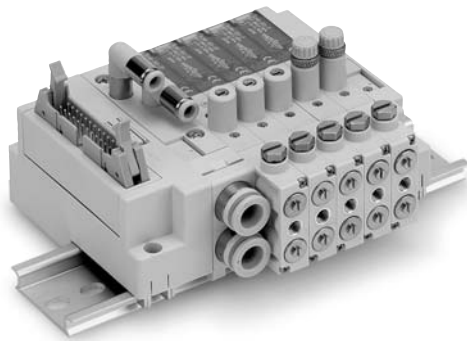

Non-plug-in Type Individual Wiring

P.74

Individual Wiring

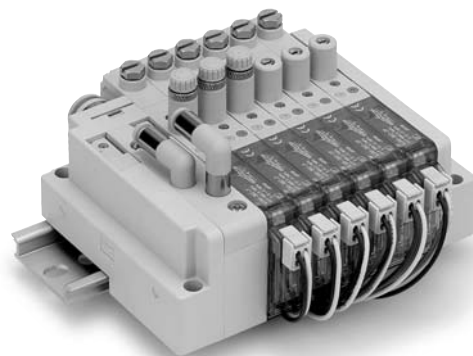

Vacuum Release Valve with Restrictor Common Specifications

Series SJ3A6

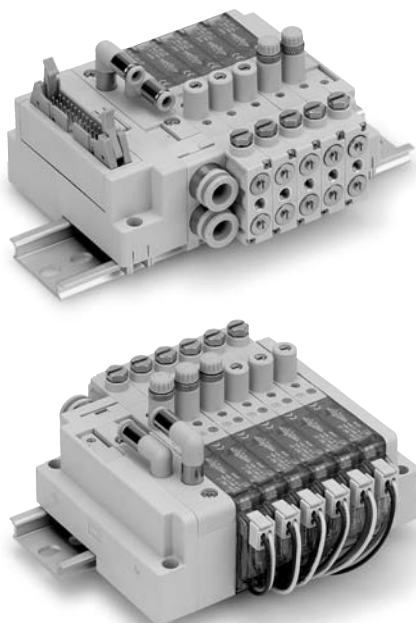

Manifold Valve Specifications

Valve construction		3 position 3 port valve with restrictor
Fluid		Air
Operating pressure range (MPa)	Release pressure port 1(P)	0.25 to 0.7
	Vacuum pressure port 3/5(E)	-100 kPa to 0.7 ^{Note 1)}
	Pilot X port	0.25 to 0.7 ^{Note 2)}
Ambient and fluid temperature (°C)		-10 to 50 (No freezing)
Max. operating frequency (Hz)		3
Manual override (Manual operation)		Non-locking push type
		Push-turn locking slotted type
Restrictor operation		Manual
		Slotted locking type
Pilot method		External pilot/Pilot valve individual exhaust
Lubrication		Not required
Mounting orientation		Unrestricted
Impact/Vibration resistance (m/s²) ^{Note 3)}		150/30
Enclosure		Dustproof

Note 1) Can be used with positive pressure to suit the application.

Note 2) Please use with pilot X port pressure equal to or higher than the release port 1(P) pressure.

Note 3) Impact resistance: No malfunction occurred when it is tested in the axial direction and at the right angles to the main valve and armature in both energised and de-energised states every once for each condition. (Values at the initial period)

Vibration resistance: No malfunction occurred in a one-sweep test between 45 and 2000 Hz. Test was performed at both energised and de-energised states in the axial direction and at the right angles to the main valve and armature. (Values at the initial period)

JIS symbol

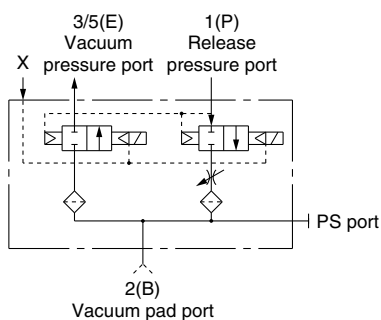

Solenoid Specifications

Coil rated voltage		24 VDC, 12 VDC
Allowable voltage fluctuation		±10% of rated voltage ^{Note)}
Power consumption (W)	Standard	0.4
	With power saving circuit (Continuous duty type)	0.15
Surge voltage suppressor		Diode
Indicator type		LED

Note) For the allowable voltage fluctuation for Z/T type (with power saving circuit), please observe the following range because they have voltage drop due to internal circuit.

Z type 24 VDC: -7% to +10%

12 VDC: -4% to +10%

T type 24 VDC: -5% to +10%

12 VDC: -6% to +10%

Response Time

Valve model	Response time ms (at 0.5 MPa)
SJ3A6-□□-□	19 or less

Weight

Valve model	Weight (g)
SJ3A6-□□-P	79

Flow Characteristics

Flow Characteristics (When restrictor is fully open)

Valve model	Fluid passage		1(P)→2(B)			2(B)→3/5(E)		
	2(B) Port size	C [dm ³ /(s·bar)]	b	Cv	C [dm ³ /(s·bar)]	b	Cv	
SJ3A6-□□-□	M5	0.24	0.19	0.05	0.40	0.18	0.10	

Restrictor Flow Characteristics [Fluid passage: 1(P)→2(B)]

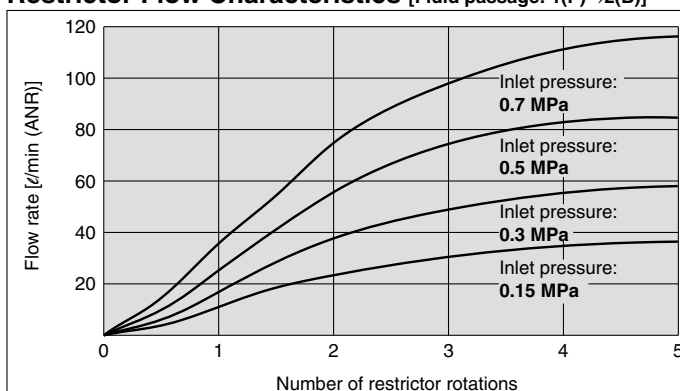

Construction

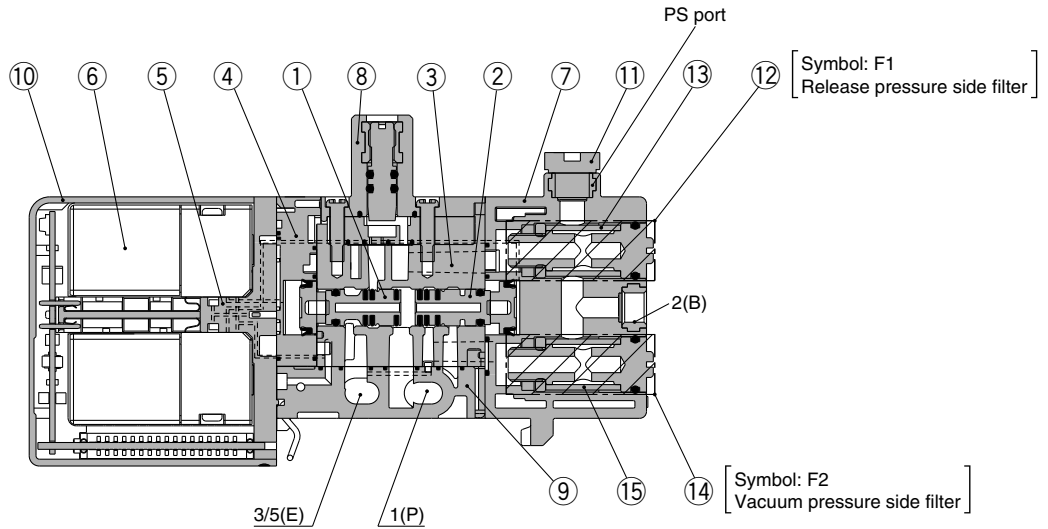

Component Parts

No.	Description	Material	Note
1	Spool valve assembly	Resin/H-NBR	A side (for release pressure switching)
2	Spool valve assembly	Resin/H-NBR	B side (for vacuum pressure switching)
3	Body	Zinc die-cast	—
4	Adaptor plate	Resin	White
5	Pilot adaptor	Resin	White
6	Pilot valve assembly	—	—
7	Body cover	Resin	White
8	Restrictor block assembly <small>(Note)</small>	Resin	White
9	Bottom cover	Resin	White
10	Light cover	Resin	Light blue

Note) Set the operating torque of the restrictor of the restrictor block assembly to 0.3 N·m or less.

Component Parts

No.	Description	Part no.	Note
11	Plug	M-5P	PS port with plug
12	Filter assembly	SJ3000-110-1A	1 μm White <Release pressure side>
13	Filter	SJ3000-107-1A	1 μm White <Release pressure side>, 5 pcs. included
14	Filter assembly	SJ3000-110-2A	30 μm Light purple <Vacuum pressure side>
15	Filter	SJ3000-107-2A	30 μm Light purple <Vacuum pressure side>, 5 pcs. included

<Filter replacement instructions>

If there are situations such as filter clogging, a drop in suction force, or slow response time, stop operation and replace the filter.:

1. Use a precision driver to remove the filter assembly (12 or 14) from the main unit.
2. Turn the filter guide by hand and remove.
3. Replace the filter (13 or 15) and gently hand tighten the filter guide. At this time, check there is no foreign matter on the O-ring of the filter assembly.
4. Return the filter assembly to the main unit.
(Tightening torque: 0.12 N·m)

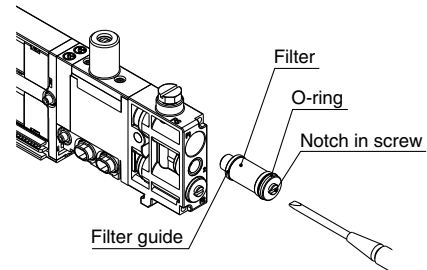

After tightening the plug (M-5P) with either a tightening torque of 1 N·m or manually, use the tightening tool and tighten it by 1/4 turn.

12,14 Filter assembly (with filter)

13,15 Filter (5 pcs. included)

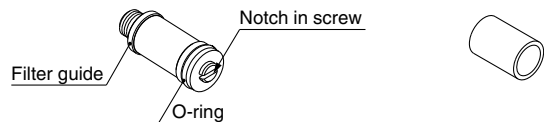

Adsorbing and Transferring System Circuit Example

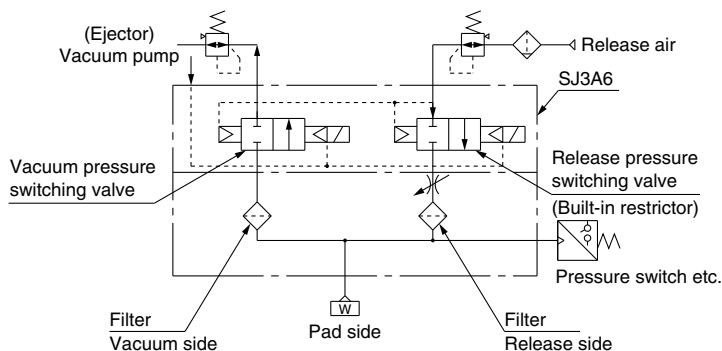

Plug-in Connector Type Vacuum Release Valve with Restrictor Series **SJ3A6**



How to Order

● Vacuum release valve manifold with restrictor

SS3J3-V60 - **05** **U**

Vacuum release valve with restrictor type

Connector type

Symbol	Mounting position	Note
FD	D-sub connector	Parallel wiring
PD	Flat ribbon cable 26 pins	
PGD	Flat ribbon cable 20 pins	
PHD	Flat ribbon cable 10 pins	
JD	Flat ribbon cable (PC wiring, without power supply terminal)	
GD	Flat ribbon cable (PC wiring, with power supply terminal)	Serial wiring
S <input type="checkbox"/>	EX180 serial transmission	
S6B	EX510 serial transmission	

Note) Refer to pages 10, 26, 34, and 42 for details.

Connector entry

With parallel wiring specifications, it is necessary to select the connector entry direction (1: upward, 2: lateral). (Only upward is available for GD.) For details, refer to page 10.

DIN rail length specified

—	Standard length	
3	3 stations	Specify a longer rail than the standard length.
⋮	⋮	
16	16 stations	

Note) Specify the valve stations not exceeding the maximum stations.

SUP/EXH block mounting position

U	U side (2 to 10 stations)
D	D side (2 to 10 stations)
B	Both sides (2 to 16 stations)
M ^{Note)}	Special specifications

Note) Specify the required specifications (Including port sizes other than ø8) by using a manifold specification sheet.

SUP/EXH block fitting spec.

—	Straight fitting	
L	Elbow fitting (Upward)	
B	Elbow fitting (Downward)	

Note) There is no need to enter anything when the SUP/EXH block mounting position "M" is selected. Also, this manifold comes standard with external pilot

How to Order Valve Manifold Assembly

Ordering example (SS3J3-V60PD2-)

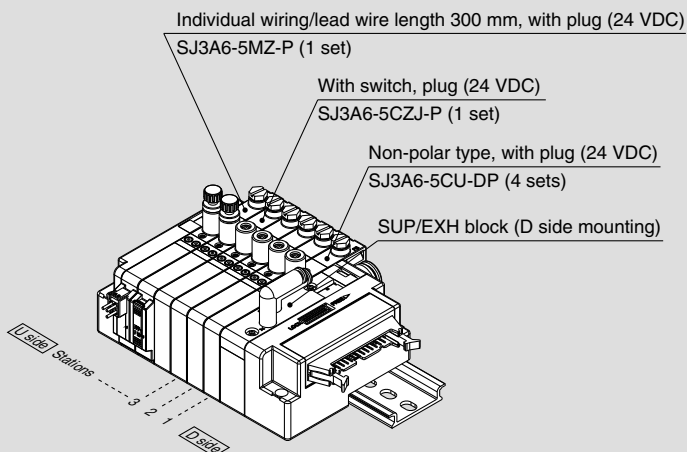

SS3J3-V60PD2-06D ... 1 set (Manifold part no.)
 * **SJ3A6-5CU-DP** 4 sets (Non-polar type, with plug part no.)
 * **SJ3A6-5CZJ-P** 1 set (With switch, plug part no.)
 * **SJ3A6-5MZ-P** 1 set (Individual wiring, lead wire length 300 mm, with plug part no.)

The asterisk denotes the symbol for assembly.
 Prefix to the part no. of the solenoid valve, etc.

- The valve arrangement is numbered as the 1st station from D side.
- Indicate the valves to be attached below the manifold part number, in order starting from station 1 as shown in the drawing.
- In the case of complex arrangement, specify them in the manifold specification sheet.

● Valve stations

F: D-sub connector

Symbol	Stations
02	2 stations
⋮	⋮
12	12 stations

PG: Flat ribbon cable (20 pins)

Symbol	Stations
02	2 stations
⋮	⋮
09	9 stations

J: Flat ribbon cable (PC wiring)

Symbol	Stations
02	2 stations
⋮	⋮
08	8 stations

G: Flat ribbon cable (PC wiring, with power supply terminal)

Symbol	Stations
02	2 stations
⋮	⋮
08	8 stations

S: EX180 serial transmission

Symbol	Stations	Note
02	2 stations	There are limitations on the station number, depending on the serial type. Refer to page 34 for details.
⋮	⋮	
16	16 stations	

P: Flat ribbon cable (26 pins)

Symbol	Stations
02	2 stations
⋮	⋮
12	12 stations

PH: Flat ribbon cable (10 pins)

Symbol	Stations
02	2 stations
⋮	⋮
04	4 stations

S6B: EX510 serial transmission

Symbol	Stations
02	2 stations
⋮	⋮
08	8 stations

Note) The number of the blanking block assembly is also included. For the blanking block assembly, please select double wiring specifications.

How to Order Solenoid Valves (3 Position 3 Port with Restrictor)

Standard

SJ3A6 □ - **5** □ **CU** □ - □ **P**

With switch

SJ3A6 - **5** □ **CZJ** □ - □ **P**

Individual wiring
 [for plug-in mixed mounting] ^{Note)}

SJ3A6 □ - **5** □ **MZ** □ - □ **P**

Note 1) Refer to pages 74 and 75 for the dedicated non-plug-in individual wiring.

Coil spec.

—	Standard
T	With power saving circuit (continuous duty type)

Note) Be sure to select "with power saving circuit" when the solenoid valve will be energised continuously for long period.

Rated voltage

5	24 VDC
6	12 VDC

Note) Only 24 VDC is available for manifolds compatible with serial wiring and PC wiring.

Common spec.

-	Positive common
N	Negative common

Note) Select nothing for non polar type

Connector entry

C: Dedicated for centralized wiring

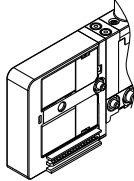

M: Individual wiring, with lead wire
Length 300 mm

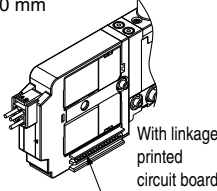

MN: Individual wiring, without lead wire (with connector, socket)

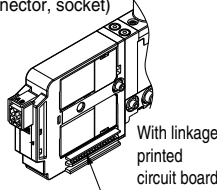

MO: Individual wiring, without connector

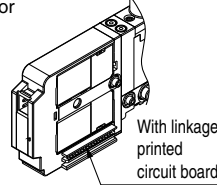

Light/surge voltage suppressor

U	With light/surge voltage suppressor (non-polar type)
Z	With light/surge voltage suppressor (polar type)

Note 1) When the types with power saving circuit, with switches, and/or individual wiring are used, the non-polar type cannot be selected.

With switch

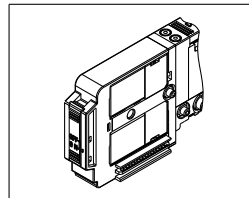

Note 1) Connector entries with the symbol "MC" can not use the switch signal from the common wiring on the manifold.

Note 2) When ordering a connector assembly separately, refer to back page 8.

Note 2) There is no valve block switch for linking the neighboring valve, etc. to the 3 position 3 port solenoid valve with restrictor. Consult SMC if you wish to use the SJ2000/3000 valve with a valve block switch, or an end block or SUP/EXH block assembly.

PS port for detection
—: M5 x 0.8



Needle operation
—: Manual



D: Slotted locking type

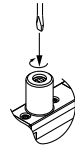

Note) Set operation torque to 0.3 N·m or less.

P: With plug (M-5P)



Note) When mounting a pressure sensor etc., select nothing.

Manual override
—: Non-locking push type

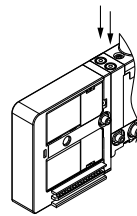

D: Push-turn locking slotted type

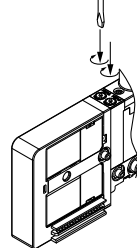

Series SJ3A6

Dimensions

SS3J3-V60 $\frac{P \square D}{J D \square}$ $\frac{1}{2}$ - Stations U/D/B
 S \square
 S6B

Applicable connector: 20 pin MIL type with strain relief (MIL-C-83503 compliant)

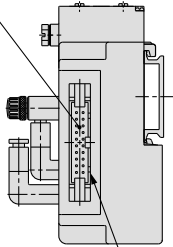

In case of 60PG (20 pins)

Applicable connector: 10 pin MIL type with strain relief (MIL-C-83503 compliant)

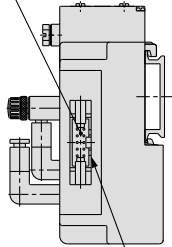

In case of 60PH (10 pins)

Applicable connector: D-sub (JIS-X-5101, MIL-C-24308) equivalent

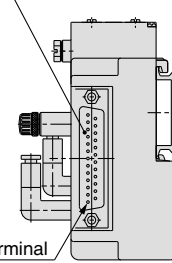

In case of 60FD

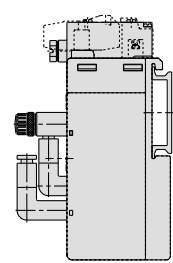

In case of 60S \square

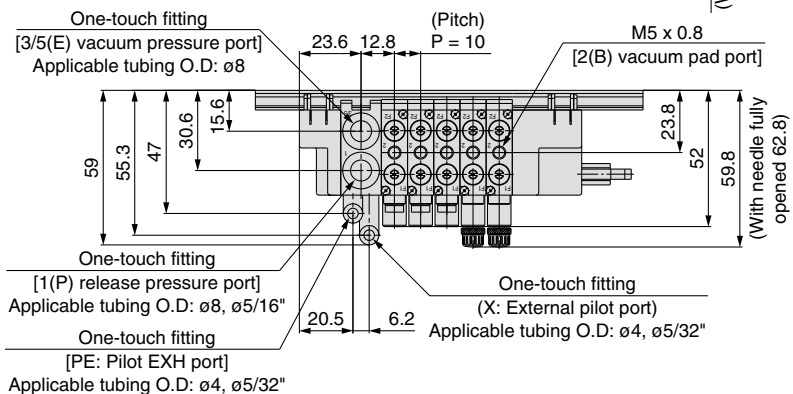
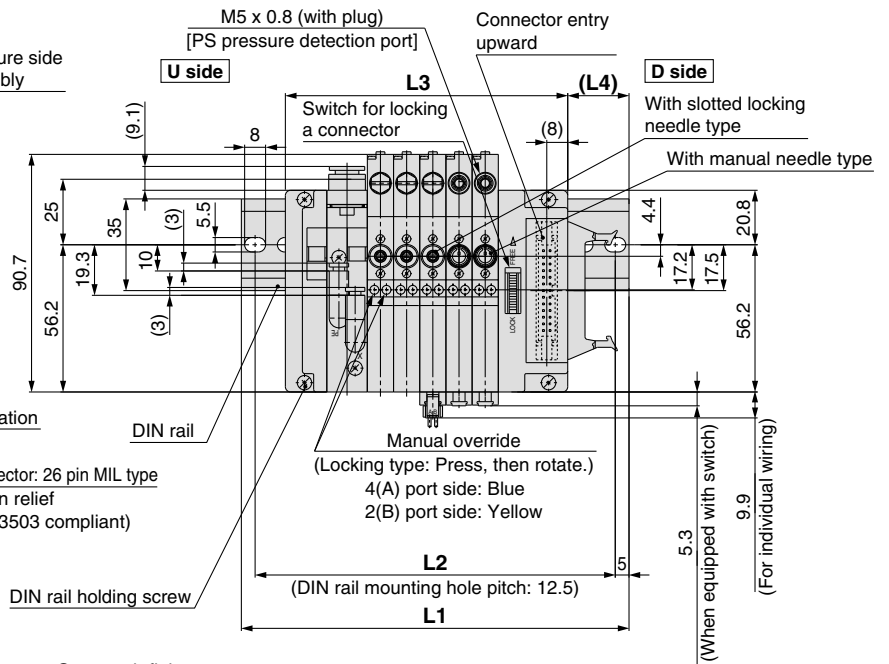
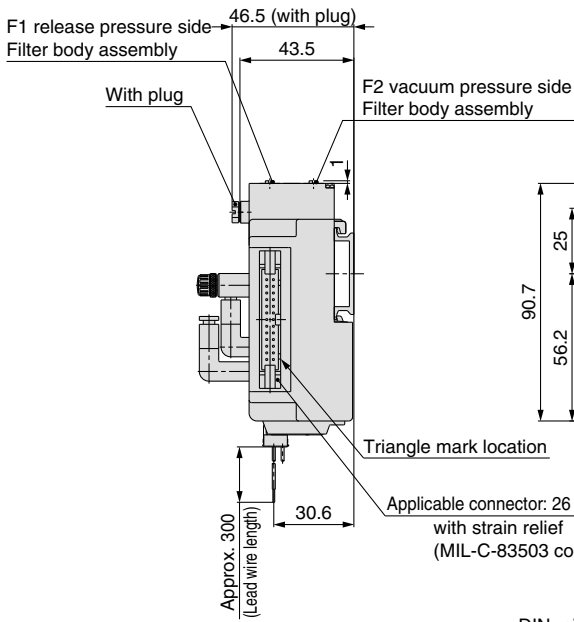
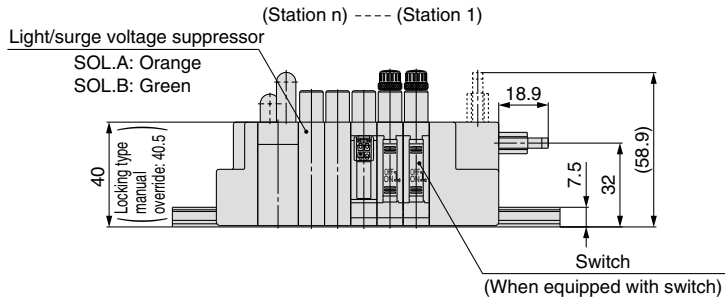

Since DIN rail dimensions are the same as the SS5J3-60 \square series, refer to the following pages.
 For D-sub connector: Page 15, 16
 For flat ribbon cable: Page 20, 21
 For EX180 serial wiring: Page 38, 39
 For EX510 serial wiring: Page 46, 47

Non-plug-in Individual Wiring Vacuum Release Valve with Restrictor Series **SJ3A6**



How to Order

● Individual wiring manifold

SS3J3-V60-05 U □ □

Vacuum release valve with restrictor type

Valve stations

Symbol	Stations
02	2 stations
⋮	⋮
20	20 stations

DIN rail length specified

—	Standard length	
3	3 stations	Specify a longer rail than the standard length.
⋮	⋮	
20	20 stations	

Note) Specify the valve stations not exceeding the maximum stations.

SUP/EXH block mounting position

U	U side (2 to 10 stations)
D	D side (2 to 10 stations)
B	Both sides (2 to 20 stations)
M <small>Note)</small>	Special specifications

Note) Specify the required specifications (including port sizes other than $\varnothing 8$) by using a manifold specification sheet.

SUP/EXH block fitting spec.

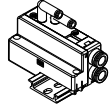
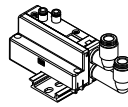
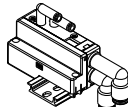
—	Straight fitting	
L	Elbow fitting (Upward)	
B	Elbow fitting (Downward)	

How to Order Valve Manifold Assembly

Ordering example (SS3J3-V60-□)

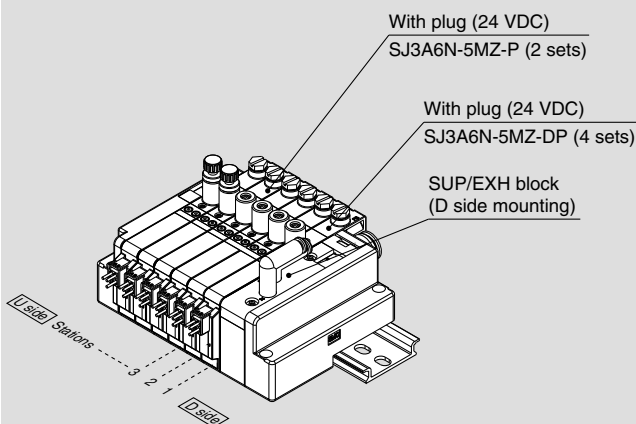

SS3J3-V60-06D 1 set (Manifold part no.)
 * SJ3A6N-5MZ-DP..... 4 sets (With plug part no.)
 * SJ3A6N-5MZ-P..... 2 sets (With plug part no.)

↳ The asterisk denotes the symbol for assembly.
 Prefix to the part no. of the solenoid valve, etc.

- The valve arrangement is numbered as the 1st station from D side.
- Indicate the valves to be attached below the manifold part number, in order starting from station 1 as shown in the drawing.
- In the case of complex arrangement, specify them in the manifold specification sheet.

Note) There is no need to enter anything when the SUP/EXH block mounting position "M" is selected. Also, this manifold comes standard with external pilot specifications.

How to Order Solenoid Valves (3 Position 3 Port with Restrictor)

SJ3A6 N-5 MZ - P

Coil spec.

—	Standard
T	With power saving circuit (continuous duty type)

Note) Be sure to select "with power saving circuit" when the solenoid valve will be energised continuously for long period.

For non-plug-in only

Rated voltage

5	24 VDC
6	12 VDC

Common spec.

-	Positive common
N	Negative common

Connector entry

M: Individual wiring, with lead wire
Length 300 mm

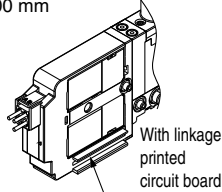

MN: Individual wiring, without lead wire (with connector, socket)

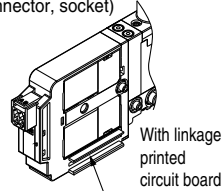

MO: Individual wiring, without connector

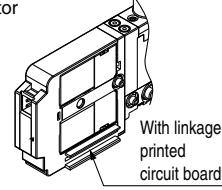

Note) When ordering a connector assembly separately, refer to back page 8.

With light/surge voltage suppressor

PS port for detection

—: M5 x 0.8



P: With plug (M-5P)



Note) When mounting a pressure sensor etc., select nothing.

Needle operation

—: Manual



D: Slotted locking type

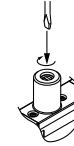

Note) Set operation torque to 0.3 N·m or less.

Manual override

—: Non-locking push type

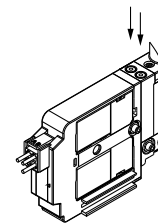

D: Push-turn locking slotted type

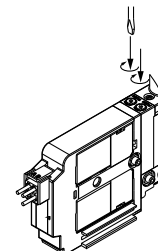

Series SJ3A6

Dimensions

SS3J3-V60- Stations U/D/B

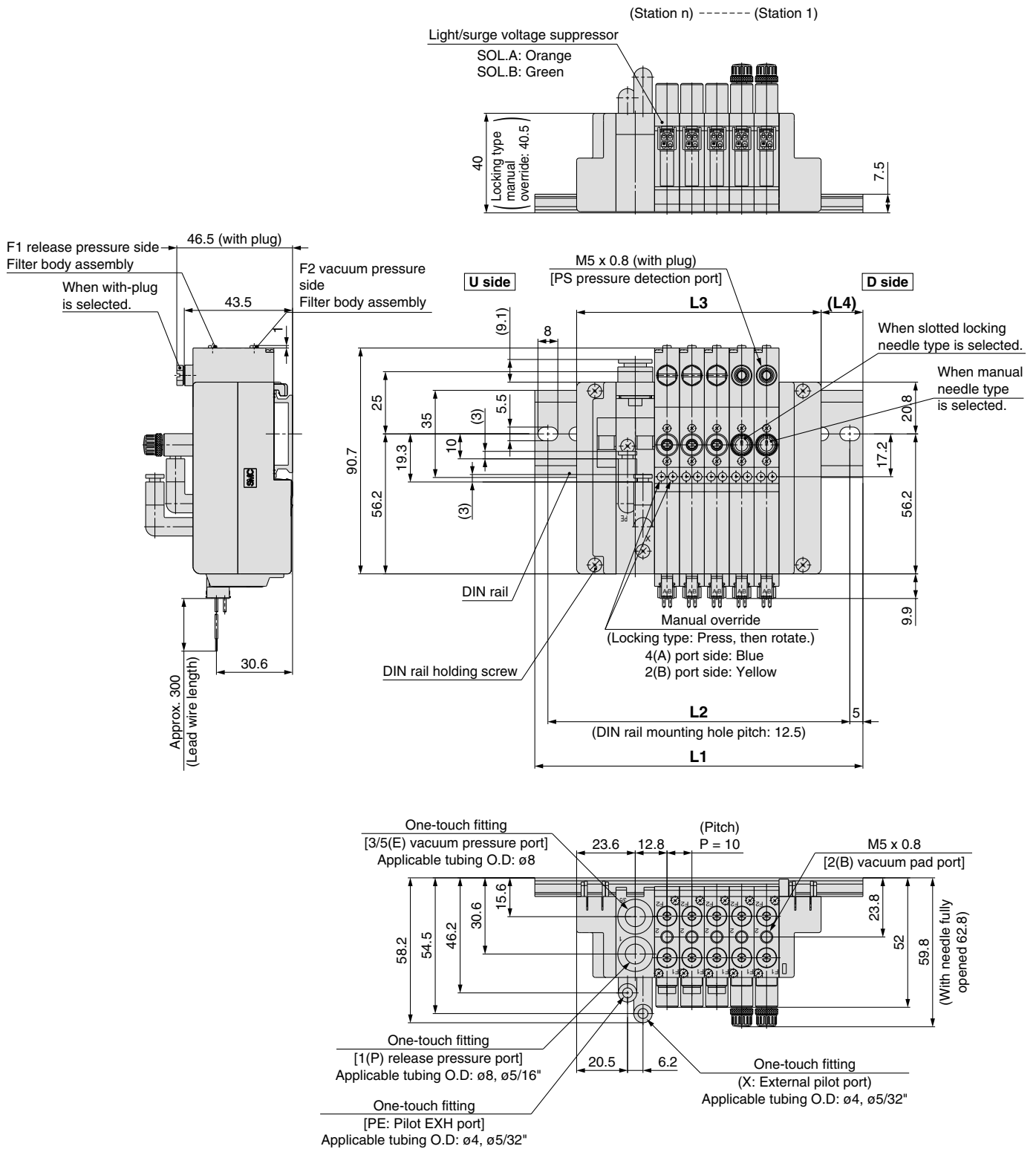

Since DIN rail dimensions are the same as the SS5J3-60-□ series, refer to pages 56 and 57.

Manifold Exploded View

Type V60P (Vacuum release valve with restrictor) manifold

Note) Refer to page 50 for "How to Add Manifold Stations."

Type V60S (Plug-in, EX180 Serial wiring) manifold

Type V60G (Plug-in, PC wiring with power supply terminal) manifold

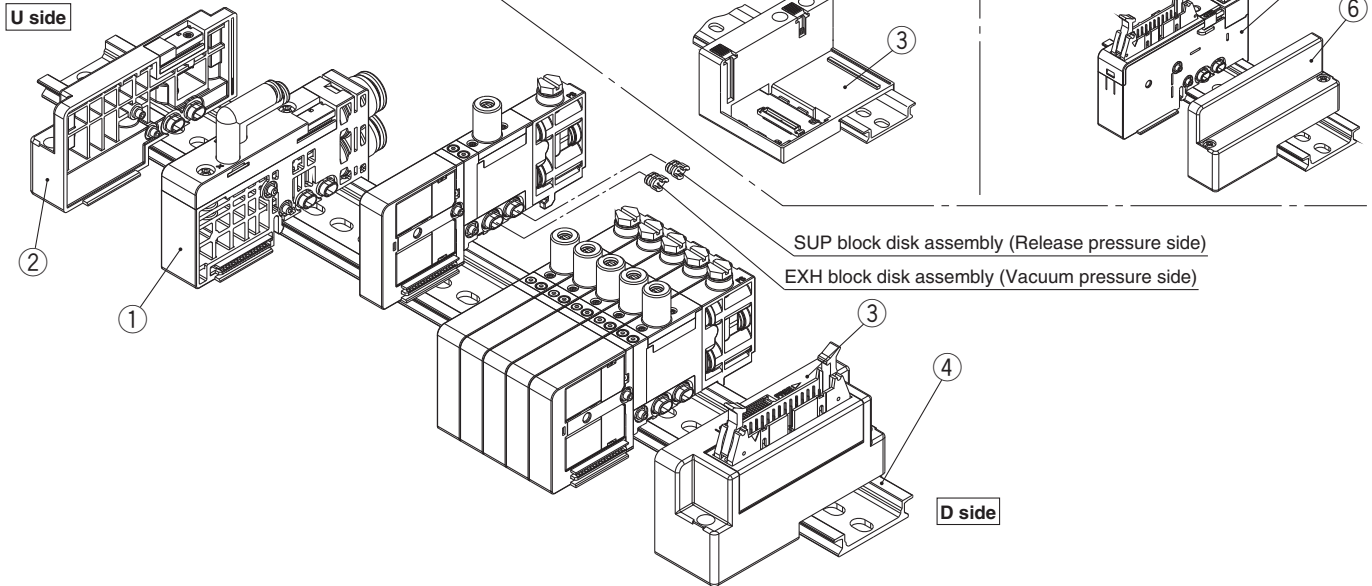

Component Parts / Plug-in

No.	Description	Part no.	Note
1 Note 1)	SUP/EXH block assembly	External pilot specification (X, PE port: Metric size $\phi 4$ Inch size $\phi 5/32$ ")	(Metric size) C6: With $\phi 6$ one-touch fitting (straight) C8: With $\phi 8$ one-touch fitting (straight) L6: With $\phi 6$ one-touch fitting (elbow upward entry) L8: With $\phi 8$ one-touch fitting (elbow upward entry) B6: With $\phi 6$ one-touch fitting (elbow downward entry) B8: With $\phi 8$ one-touch fitting (elbow downward entry)
		For different pressures Note 2)	(Inch size) N7: With 1/4" one-touch fitting (straight) N9: With 5/16" one-touch fitting (straight)
2 Note 1)	End block assembly	SJ3000-53-1A-N	For U side
3	Connector block assembly	SJ3000-42-□A-□ SJ3000-76-2A-05	Refer to the connector block assembly part no. shown below.
4	DIN rail	VZ1000-11-1-□	Refer to page 61.
5	SI unit	EX180-□□	Refer to the SI unit part numbers on page 34.
6	End block assembly	SJ3000-53-2A	For D side

Connector Block Assembly Part No.

Connector specifications	Mounting position	Part no.	Note
For D-sub connector	D side	SJ3000-42-1A-□	□: 1 (Connector upward) □: 2 (Connector lateral)
For flat ribbon cable 26 pins		SJ3000-42-2A-□	
For flat ribbon cable 20 pins		SJ3000-42-3A-□	
For flat ribbon cable 10 pins		SJ3000-42-4A-□	
For PC wiring 20 pins		SJ3000-42-6A-□	
For EX180 serial wiring Note)		SJ3000-42-20A	
For PC wiring 20 pins with power supply terminal		SJ3000-76-2A-05	

Note) SI unit is not included.

Component Parts / Non-plug-in

No.	Description	Part no.	Note
1 Note 1)	SUP/EXH block assembly	External pilot specification (X, PE port: Metric size $\phi 4$ Inch size $\phi 5/32$ ")	(Metric size) C6: With $\phi 6$ one-touch fitting (straight) C8: With $\phi 8$ one-touch fitting (straight) L6: With $\phi 6$ one-touch fitting (elbow upward entry) L8: With $\phi 8$ one-touch fitting (elbow upward entry) B6: With $\phi 6$ one-touch fitting (elbow downward entry) B8: With $\phi 8$ one-touch fitting (elbow downward entry)
		For different pressures Note 2)	(Inch size) N7: With 1/4" one-touch fitting (straight) N9: With 5/16" one-touch fitting (straight)
2 Note 1)	End block assembly	SJ3000-53-1A-N	For U side
4	DIN rail	VZ1000-11-1-□	Refer to page 61.
6	End block assembly	SJ3000-53-2A	For D side

Note 1) For the SJ3A6 series, valve block and manual switches are not available.

Note 2) The valves cannot be operated only with the SUP/EXH block assembly for different pressure, select in combination with the SUP/EXH block assembly for internal/external pilot.

Note 3) Refer to page 60 about the SUP/EXH block disk assembly and method of handling of parts at different pressure.





Safety Instructions

These safety instructions are intended to prevent a hazardous situation and/or equipment damage. These instructions indicate the level of potential hazard by labels of “**Caution**,” “**Warning**” or “**Danger**.” They are all important notes for safety and must be followed in addition to International Standards (ISO/IEC) ^{Note 1)} and other safety regulations.

Note 1) ISO 4414: Pneumatic fluid power – General rules relating to systems.
ISO 4413: Hydraulic fluid power – General rules relating to systems.
IEC 60204-1: Safety of machinery – Electrical equipment of machines. (Part 1: General requirements)
ISO 1021: Manipulating industrial robots -Safety.
etc.

 **Caution:** Operator error could result in injury or equipment damage.

 **Warning:** Operator error could result in serious injury or loss of life.

 **Danger :** In extreme conditions, there is a possibility of serious injury or loss of life.

Warning

■ Selection/Handling/Applications

1. The compatibility of pneumatic equipment is the responsibility of the person who designs the pneumatic system or decides its specifications.

Since the products specified here are used in various operating conditions, their compatibility for the specific pneumatic system must be based on specifications or post analysis and/or tests to meet your specific requirements. The expected performance and safety assurance are the responsibility of the person who has determined the compatibility of the system. This person should continuously review the suitability of all item specified, referring to the latest catalogue information with a view to giving due consideration to any possibility of equipment failure when configuring a system.

2. Only trained personnel should operate pneumatically operated machinery and equipment.

Compressed air can be dangerous if handled incorrectly. Assembly, handling or repair of pneumatic systems should be performed by trained and experienced operators. (Understanding JIS B 8370 General Rules for Pneumatic Equipment, and other safety rules are included.)

3. Do not service machinery/equipment or attempt to remove components until safety is confirmed.

1. Inspection and maintenance of machinery/equipment should only be performed once measures to prevent falling or runaway of the driven objects have been confirmed.
2. When equipment is removed, confirm the safety process as mentioned above. Turn off the supply pressure for this equipment, exhaust all residual compressed air in the system, and release all energy (liquid pressure, spring, condenser and gravity).
3. Before machinery/equipment is restarted, take measures to prevent quick extension of a cylinder piston rod, etc.

4. If the equipment will be used in the following conditions or environment, please contact SMC first and be sure to take all necessary safety precautions.

1. Conditions and environments beyond the given specifications, or if product is used outdoors or with direct sun lights.
2. Installation on equipment in conjunction with atomic energy, railway, air navigation, vehicles, medical equipment, food and beverages, recreation equipment, emergency stop circuits, clutch and brake circuits in press applications, or safety equipment.
3. An application which has the possibility of having negative effects on people, property, requiring special safety analysis.
4. If the products are used in an interlock circuit, prepare a double interlock style circuit with a mechanical protection function for the prevention of a breakdown. And, examine the devices periodically if they function normally or not.



Series SJ2000/3000 Specific Product Precautions 1

Be sure to read this before handling. Please refer to "Precautions for Handling Pneumatic Devices" (M-03-E3A) for Safety Instructions and 3/4/5 Port Solenoid Valves Precautions.

Manual Override Switch Operation

Warning

For manual override operation, move the manual override switch to a position where letters A and B can be seen. [Manual override switch release status (refer to the figure below)] Operation with the manual override switch in a locked status can cause damage to the manual override and air leakage, so be sure to release the manual override switch before use. After manual override operation, lock the manual switch for use (when the manual override of the push-turn locking slotted type is locked, manual override switch cannot be locked).

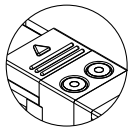

Manual override switch locked status

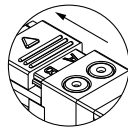

Manual override switch unlocked status

Manual override switch slide direction

Manual Override Operation

Warning

When the manual override is operated, connected equipment will be actuated. Confirm safety before operating.

Non-locking push type

Press in the direction of the arrow.

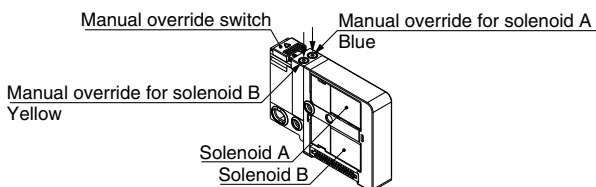

Push-turn locking slotted type

While pressing, turn in the direction of the arrow (90° clockwise). If it is not turned, it can be used in the same way as the non-locking push type.

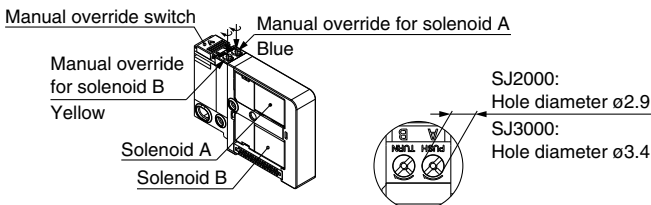

Enlarged view of manual override part

Caution

When D type is operated with a screwdriver, it must be turned gently using a watchmaker's screwdriver. [Torque: under 0.05 N·m]

When the manual override of the D type is locked, it must be pushed before turning. [Load: 10 N or less] Turning without pushing can cause damage to the manual override and trouble such as air leakage, etc.

Valve with Switch

Warning

When turning off the valve using the switch, move it to the position where the valve is locked. If the switch is at an improper position and is energised, equipment connected to the valve could be actuated.

Also, if the switch is turned OFF on the valve in the energised state, be careful because any actuators connected to a single solenoid, a dual 3 port valve or a 3 position valve will actuate.

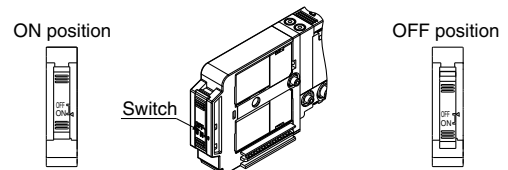

Normal operation: The valve is switched according to electric signals from the connector on the manifold side.

The valve coil is kept in a deenergised state even when there is an electric signal from the connector on the manifold side.

Electric circuit diagram (with positive common and light/surge voltage suppressor)

Positive common specification:

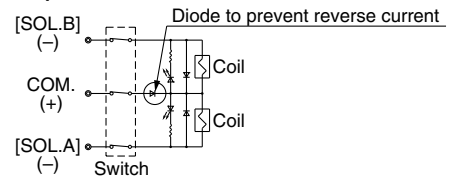

Negative common specification:

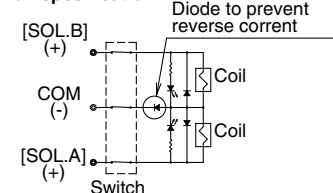

Built-in Back Pressure Check Valve Type

Caution

Valves with built-in back pressure check valve is to protect the back pressure inside a valve. For this reason, valves with external pilot specification cannot be pressurized from exhaust port [3/5(E)].

As compared with the types which do not integrate the back pressure check valve, C value of the flow characteristics goes down. For details, please contact SMC.

Exhaust Restriction

Caution

Since the SJ series is a type in which the pilot valve exhaust joins the main valve exhaust inside the valve, use caution, so that the piping from the exhaust port is not restricted.



Series SJ2000/3000 Specific Product Precautions 2

Be sure to read this before handling. Please refer to "Precautions for Handling Pneumatic Devices" (M-03-E3A) for Safety Instructions and 3/4/5 Port Solenoid Valves Precautions.

When Using a 4 Port Valve as a 3 Port Valve

Caution

When using a 4 port valve as a 3 port valve

The SJ2000/3000 series can be used as normally closed (N.C.) or normally open (N.O.) 3 port valves by plugging one of the cylinder ports 4(A) or 2(B). However, exhaust ports should be left open. It is convenient when a double solenoid 3 port valve is required.

Plug position	2(B) port	4(A) port
Type of actuation	N.C.	N.O.
Number of solenoids	Single (A)(B) 4 2 5 1 3 (EA)(P)(EB)	Single (A)(B) 4 2 5 1 3 (EA)(P)(EB)
	Double (A)(B) 4 2 5 1 3 (EA)(P)(EB)	Double (A)(B) 4 2 5 1 3 (EA)(P)(EB)

Light/surge Voltage Suppressor

Caution

Non-polar type

Single solenoid

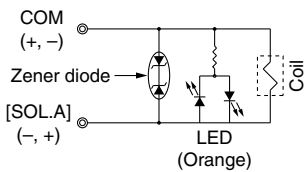

Double solenoid, 3 position type

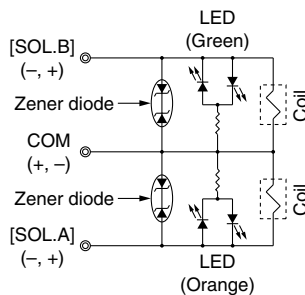

Polar type

Positive common specification:

Single solenoid

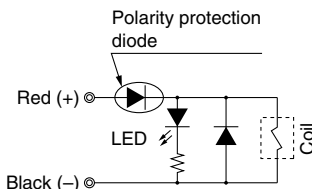

Double solenoid, 3 position type

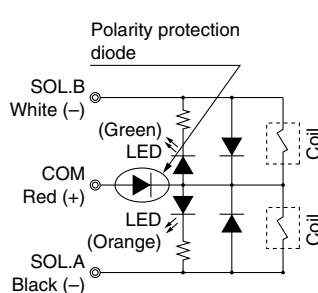

Negative common specification:

Single solenoid

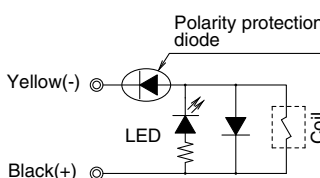

Double solenoid, 3 position type

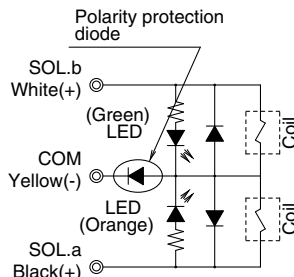

Continuous Duty

Caution

If a valve is energised continuously for a long time, the temperature rise due to heat-up of the coil may cause a decline in solenoid valve performance, reduce product life, or have adverse effects on peripheral equipment. If a valve is to be energised continuously, please be sure to use the "Continuous duty type" with a power saving circuit. In particular, there will be a large increase in temperature if 3 or more neighboring stations are simultaneously and continuously energised for a long time, or if the A and B sides are simultaneously and continuously energised for a long time in a dual 3 port valve. Please be very careful in these cases.

With power saving circuit

Compared to the standard products, power consumption is reduced down to approx. 1/3 (in case of SJ3□60T) by cutting the unnecessary wattage required to hold the valve in an energised state. (Effective energising time is over 67 ms at 24 VDC.)

Electric circuit diagram (with power saving circuit) In case of single solenoid

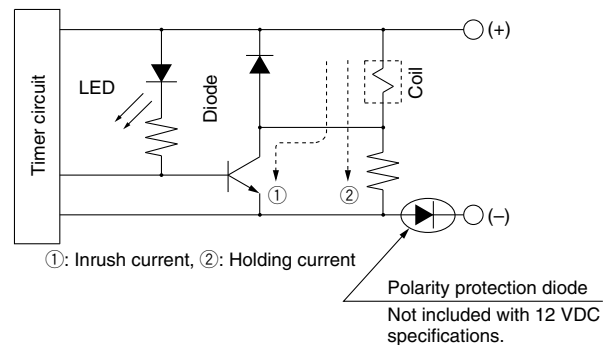



Series SJ2000/3000 Specific Product Precautions 3

Be sure to read this before handling. Please refer to “Precautions for Handling Pneumatic Devices” (M-03-E3A) for Safety Instructions and 3/4/5 Port Solenoid Valves Precautions.

Working Principle

With the circuit of back page 4, the current consumption, when holding, is reduced to save energy. Please refer to the electric wave data below.

In case of SJ3□60T, electric waveform of energy saving type

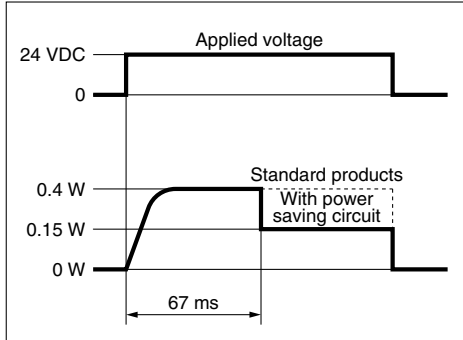

- When a power saving circuit is installed, a diode to prevent reverse current is not available for 12 V DC spec. Therefore, use caution not to connect in reverse.
- Be careful about the allowable voltage fluctuation since a voltage drop of about 0.5 V occurs due to a transistor. (Refer to the solenoid specifications of each valve for details.)

Measures to prevent of surge voltage detours

When the DC power supply is shut off, for example by the emergency breaking circuit, valve misoperation may occur due to surge voltage produced by other electrical parts (such as electromagnetic coils). Please take measures to prevent surges detouring to the valve (surge protection diode etc.), or use a valve with diode to prevent reverse current (polar: Z type). However, surge countermeasures are provided on the serial unit side of the serial type.

Circuit example

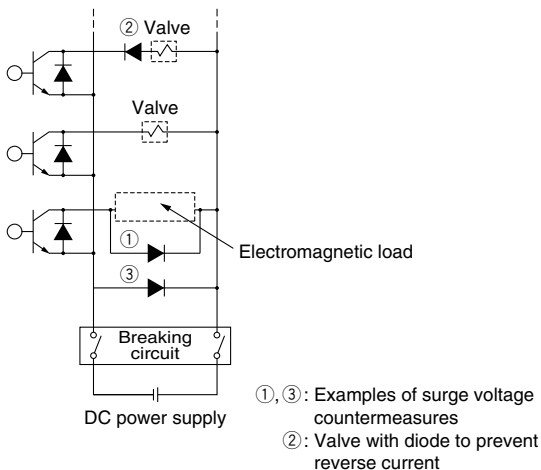

Light Indication

Caution

When equipped with light/surge voltage suppressor, the light window turns orange when solenoid A is energised, and it turns green when solenoid B is energised.

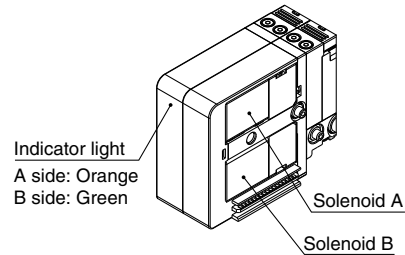

Changing the Connector Entry Direction

Caution

To change the connector's entry direction, set the switch on the top of the connector block to the FREE position, before turning the connector. Make sure to slide the switch back to the LOCK position before connecting the connector. (When the switch is difficult to slide, move the connector a little so that it will slide easier.)

If an excessive force is applied on the connector in the LOCK position, the connector block may be damaged. Also, using in such a way that the connector floats in the FREE position, it may cause the lead wire, etc. to break. Thus, refrain from using in these ways.

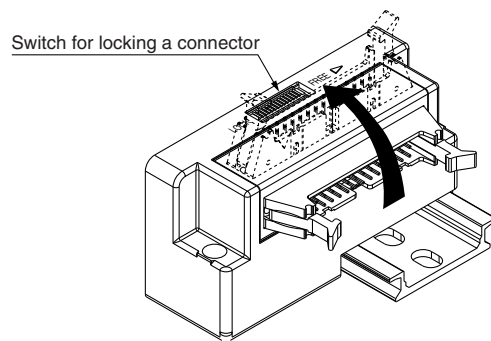

Manifold Mounting

When attaching a manifold to a mounting surface, etc., with bolts, if the entire bottom surface of the DIN rail contacts the mounting surface in a horizontal mounting, it can be used by simply securing both ends of the DIN rail. However, for any other mounting method or for side facing and rear facing, etc., secure the DIN rail with bolts at uniform intervals using the following as a guide: 2 to 5 stations at 2 locations, 6 to 10 stations at 3 locations, 11 to 15 stations at 4 locations, 16 to 20 stations at 5 locations, 21 to 25 stations at 6 locations, 26 to 30 stations at 7 locations and more than 30 stations at 8 locations.

In addition, even in the case of a horizontal mounting, if the mounting surface is subject to vibration, etc., take the same measures indicated above. If secured at fewer than the specified number of locations, warping or twisting may occur in the DIN rail and manifold, causing trouble such as air leakage.



Series SJ2000/3000 Specific Product Precautions 4

Be sure to read this before handling. Please refer to “Precautions for Handling Pneumatic Devices” (M-03-E3A) for Safety Instructions and 3/4/5 Port Solenoid Valves Precautions.

Fitting Assembly Replacement

Caution

By replacing a valve's fitting assembly, it is possible to change the port size of the 4(A), 2(B), 1(P), and 3/5(E) ports. When replacing the fitting assembly, pull it out after removing the clip with a flat head screwdriver, etc. To mount a new fitting assembly, insert it into place and then fully reinsert the clip.

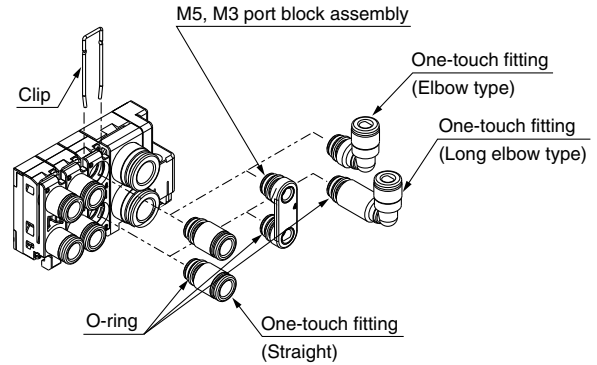

Fitting Assembly Part No.

Metric Size

Port	Port size	Part no.
SJ2000 4(A) 2(B)	ø2 one-touch fitting assembly (Straight)	KJH02-C1
	ø4 one-touch fitting assembly (Straight)	KJH04-C1
	ø2 one-touch fitting assembly (Elbow type)	KJL02-C1
	ø4 one-touch fitting assembly (Elbow type)	KJL04-C1-N
	ø2 one-touch fitting assembly (Long elbow type)	KJW02-C1
	ø4 one-touch fitting assembly (Long elbow type)	KJW04-C1-N
	M3 port block assembly	SJ2000-56-1A
SJ3000 4(A) 2(B)	ø2 one-touch fitting assembly (Straight)	KJH02-C2
	ø4 one-touch fitting assembly (Straight)	KJH04-C2
	ø6 one-touch fitting assembly (Straight)	KJH06-C2
	ø2 one-touch fitting assembly (Elbow type)	KJL02-C2
	ø4 one-touch fitting assembly (Elbow type)	KJL04-C2
	ø6 one-touch fitting assembly (Elbow type)	KJL06-C2-N
	ø2 one-touch fitting assembly (Long elbow type)	KJW02-C2
	ø4 one-touch fitting assembly (Long elbow type)	KJW04-C2
	ø6 one-touch fitting assembly (Long elbow type)	KJW06-C2-N
	M5 port block assembly	SJ3000-56-1A
	1(P) 3/5(E)	ø6 one-touch fitting assembly (Straight)
ø6 one-touch fitting assembly (Elbow type)		SZ3000-74-1A-L6
ø6 one-touch fitting assembly (Long elbow type)		SZ3000-74-2A-L6
ø8 one-touch fitting assembly (Straight)		VVQ1000-51A-C8
ø8 one-touch fitting assembly (Elbow type)		SZ3000-74-1A-L8
ø8 one-touch fitting assembly (Long elbow type)		SZ3000-74-2A-L8

Inch Size

Port	Port size	Part no.
SJ2000 4(A) 2(B)	ø1/8" one-touch fitting assembly (Straight)	KJH01-C1
	ø5/32" one-touch fitting assembly (Straight)	KJH03-C1
	ø1/8" one-touch fitting assembly (Elbow type)	KJL01-C1
	ø5/32" one-touch fitting assembly (Elbow type)	KJL03-C1
	ø1/8" one-touch fitting assembly (Long elbow type)	KJW01-C1
	ø5/32" one-touch fitting assembly (Long elbow type)	KJW03-C1
SJ3000 4(A) 2(B)	ø1/8" one-touch fitting assembly (Straight)	KJH01-C2
	ø5/32" one-touch fitting assembly (Straight)	KJH03-C2
	ø1/4" one-touch fitting assembly (Straight)	KJH07-C2
	ø1/8" one-touch fitting assembly (Elbow type)	KJL01-C2
	ø5/32" one-touch fitting assembly (Elbow type)	KJL03-C2
	ø1/4" one-touch fitting assembly (Elbow type)	KJL07-C2
	ø1/8" one-touch fitting assembly (Long elbow type)	KJW01-C2
	ø5/32" one-touch fitting assembly (Long elbow type)	KJW03-C2
1(P) 3/5(E)	ø1/4" one-touch fitting assembly (Straight)	VVQ1000-51A-N7
	ø5/16" one-touch fitting assembly (Straight)	VVQ1000-51A-N9

Note 1) To change the port size of the 1(P), 3/5(E) ports into the port sizes other than ø8 (straight), specify the change by using a manifold specification sheet.

Note 2) Be careful to avoid damage or contamination to the O-rings, as this can cause air leakage.

Note 3) When removing a straight-type fitting assembly from a valve, after removing the clip, attach tubing or a plug (KJP-02, KQ2P-□□) to the one-touch fitting, and pull it out while holding the tubing or plug. If it is pulled out while holding the release button of the fitting assembly (resin part), the release button may be damaged.

Note 4) Be sure to turn off the power and stop the supply of air before disassembly. Furthermore, since air may remain inside the actuator, piping and manifold, confirm that the air is completely exhausted before starting any work.

Note 5) While inserting a tubing into an elbow-type fitting assembly, hold the main body of the assembly by hand. Failure to do so will exert an undue force on the valve or the fitting assembly, resulting in air leakage or damage.



Series SJ2000/3000 Specific Product Precautions 5

Be sure to read this before handling. Please refer to "Precautions for Handling Pneumatic Devices" (M-03-E3A) for Safety Instructions and 3/4/5 Port Solenoid Valves Precautions.

One-touch Fittings

Caution

The pitch of the SJ series piping ports (A, B etc.) has been set assuming the use of KJ series one-touch fittings. Therefore, when using fittings with an M3 or M5 port block assembly, there may be some interference between fittings, depending on the type and size, so please use after checking dimensions in the catalogue for the pipe fitting being used.

1. Tube attachment/detachment for one-touch fittings

1) Attaching of tubing:

- (1) Take a tube having no flaws on its periphery and cut it off at a right angle. When cutting the tube, use tube cutters TK-1, 2 or 3. Do not use pinchers, nippers or scissors, etc. If cutting is done with tools other than tube cutters, there is the danger that the tube may be cut diagonally or become flattened, etc., making a secure installation impossible, and causing problems such as the tube pulling out after installation or air leakage.

Also allow some extra length in the tube.

- (2) Grasp the tube and push it in slowly, inserting it securely all the way into the fitting.
- (3) After inserting the tube, pull on it lightly to confirm that it will not come out. If it is not installed securely all the way into the fitting, this can cause problems such as air leakage or the tube pulling out.

2) Detaching of tubing:

- (1) The 4(A) and 2(B) ports use the KJ series, so the tube can be removed by pressing on part of the release bush. However, for the 1(P) and 3/5(E) ports, please press the release bush evenly as before.

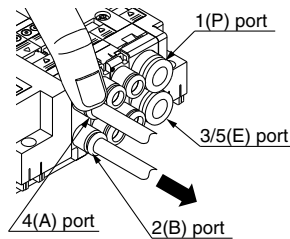

Hold down part of the release bush with your finger or a similar tool, as shown in the diagram, and pull out in the direction indicated by the arrow.

- (2) Pull out the tube while holding down the release button so that it does not come out. If the release button is not pressed down sufficiently, there will be increased bite on the tube and it will become more difficult to pull it out.
- (3) When the removed tube is to be used again, cut off the portion which has been chewed before reusing it. If the chewed portion of the tube is used as is, this can cause trouble such as air leakage or difficulty in removing the tube.

Other Tubing Brands

Caution

1. When using tube other than SMC brand, confirm the following specifications are satisfied with respect to the outside diameter tolerance of the tube.

- 1) Nylon tubing within ± 0.1 mm
- 2) Soft nylon tubing within ± 0.1 mm
- 3) Polyurethane tubing within $+0.15$ mm, within -0.2 mm

Do not use tubing which does not meet these outside diameter tolerances. It may not be possible to connect them, or they may cause other troubles, such as air leakage or the tube pulling out after connection.

How to Use Plug Connector

Caution

When attaching and detaching a connector, first shut off the electric power and the air supply.

Also, crimp the lead wires and sockets securely.

1. Attaching and detaching connectors

- To attach a connector, hold the lever and connector unit between your fingers and insert straight onto the pins of the solenoid valve so that the lever's pawl is pushed into the groove and locks.
- To detach a connector, remove the pawl from the groove by pushing the lever downward with your thumb, and pull the connector straight out.

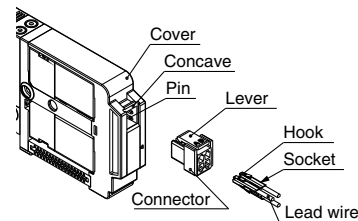

2. Crimping of lead wires and sockets

Strip 3.2 to 3.7 mm of insulation from the tip of lead wire, enter the core wires neatly into a socket and crimp it with a special crimp tool. Be careful so that the cover of lead wire does not enter into the crimping part. (Crimping tool: Model no. DXT170-75-1)

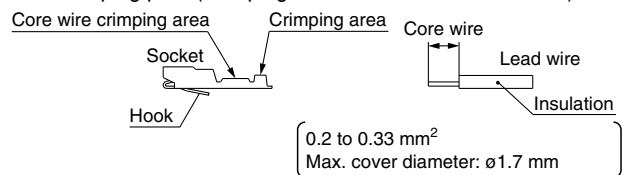

3. Attaching and detaching lead wires with sockets

• Attaching

Insert the sockets into the square holes of the connector (with A, B, C, and N indication), and continue to push the sockets all the way in until the lock by hooking into the seats in the connector. (When they are pushed in, their hooks open and they are locked automatically.) Next, confirm that they are locked by pulling lightly on the lead wires.

• Detaching

To detach a socket from a connector, pull out the lead wire while pressing the socket's hook with a stick having a thin tip (approx. 1 mm). If the socket is used again, spread the hook outward.

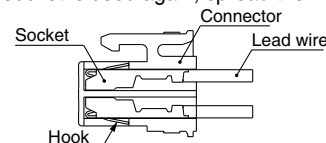

Positive common specification:

Single solenoid

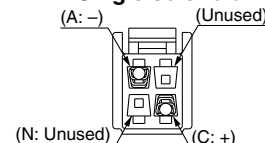

Double solenoid

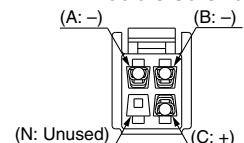

Negative common specification:

Single solenoid

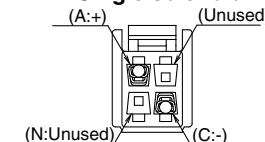

Double solenoid

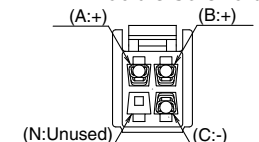



Series SJ2000/3000 Specific Product Precautions 6

Be sure to read this before handling. Please refer to "Precautions for Handling Pneumatic Devices" (M-03-E3A) for Safety Instructions and 3/4/5 Port Solenoid Valves Precautions.

Plug Connector Lead Wire Length

Caution

Plug connector lead wires have a standard length of 300 mm, however, the following lengths are also available.

Connector Assembly Part No.

Positive common specification

Single solenoid
SJ3000-46-S-□

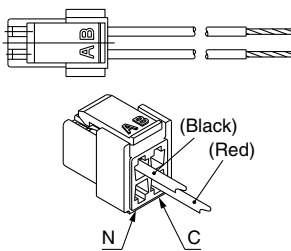

Double solenoid,
3 position type, 4 position type
SJ3000-46-D-□

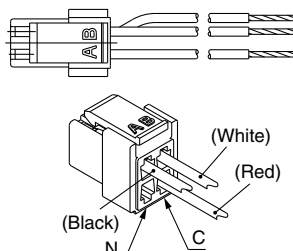

Negative common specification

Single solenoid
SJ3000-47-S-□

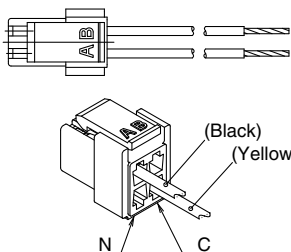

Double solenoid,
3 position type, 4 position type
SJ3000-47-D-□

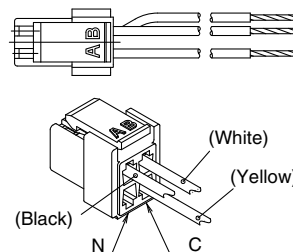

Positive common specification

For single solenoid: SJ3000-46-S-□

For double solenoid:

For 3/4 position type: SJ3000-46-D-□

For 4 position type

Negative common specification

For single solenoid: SJ3000-47-S-□

For double solenoid:

For 3/4 position type: SJ3000-47-D-□

For single solenoid:

Without lead wire: SJ3000-46-S-N

(Connector, Socket x 2 pcs. only)

For double solenoid:

Without lead wire : SJ3000-46-D-N

(Connector, Socket x 3 pcs. only)

How to Order

Include the connector assembly part number together with the part number for the plug connector's solenoid valve without connector.

Example: Lead wire length 2000 mm

SJ3160-5MOZ-C6

SJ3000-46-S-20

Lead wire length

Nil	300 mm
6	600 mm
10	1000 mm
15	1500 mm
20	2000 mm
25	2500 mm
30	3000 mm
50	5000 mm

Connector Assembly for Manifolds (for Junction Common)

Caution

Using the connector assembly (for junction common) for solenoid valves installed in the manifold reduces the labour involved in wiring work because common wiring for all solenoid valves is integrated into a single wire.

Connector Assembly Part No. (for Junction Common)

Positive common specification

Single solenoid
SJ3000-46-SC-□

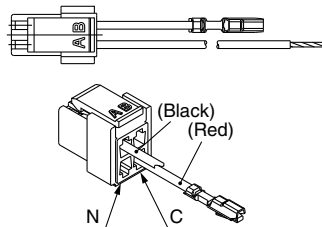

Double solenoid,
3 position type, 4 position type
SJ3000-46-DC-□

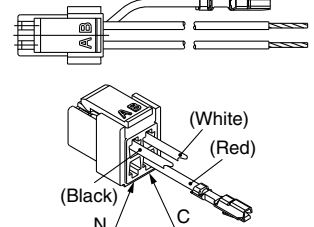

Negative common specification

Single solenoid
SJ3000-47-SC-□

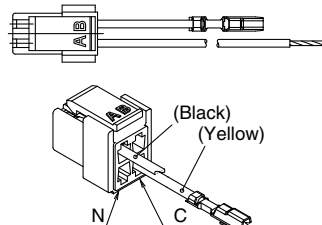

Double solenoid,
SJ3000-47-DC-□

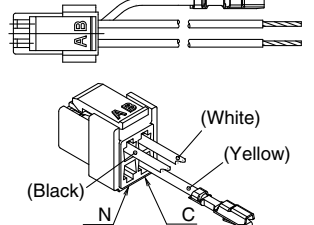

Positive common specification

For single solenoid: SJ3000-46-SC-□

For double solenoid:

For 3/4 position type: SJ3000-46-DC-□

For junction common ●

Negative common specification

For single solenoid: SJ3000-47-SC-□

For double solenoid:

For 3/4 position type: SJ3000-47-DC-□

For junction common ●

Lead wire length

Nil	300 mm
6	600 mm
10	1000 mm
15	1500 mm
20	2000 mm
25	2500 mm
30	3000 mm
50	5000 mm

How to Order

Indicate the part no. of the connector assembly for the manifold and solenoid valve.

If the arrangement is complicated, please specify them by using the manifold specification sheet.

Note 1) Applications like connectors not wired to a valve are not possible.

Note 2) For the solenoid valve, please designate "No connector (MOZ)" for the connector type.

Note 3) Connector assembly with lead wire for place where the signals are transmitted to the common wiring. (Only the valves of first station and/or last station of manifold are compatible to connector with lead wire for common.)



Series SJ2000/3000 Specific Product Precautions 7

Be sure to read this before handling. Please refer to "Precautions for Handling Pneumatic Devices" (M-03-E3A) for Safety Instructions and 3/4/5 Port Solenoid Valves Precautions.

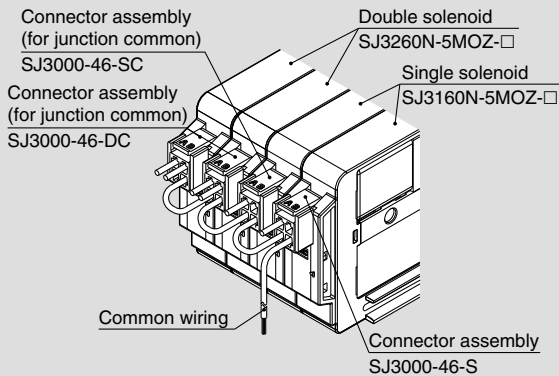

(Example)

- SS5J3-60-04U 1 set
- * SJ3160N-5MOZ 2 sets
- * SJ3260N-5MOZ 2 sets
- * SJ3000-46-S 1 set (Connector assembly for single solenoid)
- * SJ3000-46-SC 1 set (Connector assembly for single solenoid (for junction common))
- * SJ3000-46-DC 2 sets (Connector assembly for double solenoid (for junction common))

→ The asterisk denotes the symbol for assembly. Prefix it to the part nos. of the solenoid valve, etc.

Wiring Instructions for Connector Assembly (for Junction Common)

⚠ Caution

If only connector assembly (for junction common) is ordered, please wire according to the diagram below. For details on socket mounting, please refer to "How to Use Plug Connector" on back page 7.

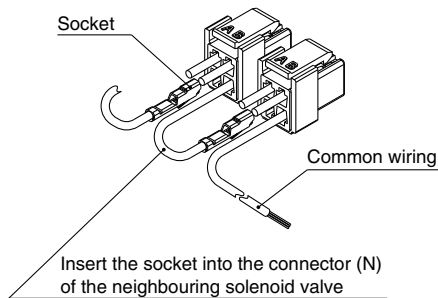

How to Wire to PC Wiring System Compliant Power Supply Terminal

⚠ Caution

Wire connection instructions:

- Strip 6.5 to 7.5 mm from the tip of the lead wire.
- Loosen the terminal screws (slotted screws) of the power supply terminal connectors, plug the core wire of the lead wire into the square holes of the connector, tighten terminal screws at the proper torque, and fasten them securely. (Gently pull the lead wire and check it is fastened.)

Precautions:

- To remove the power supply terminal connector, pull it upward. When mounting, push it in until it makes a snapping noise.
- When connecting wire, be careful it lead wire outside of compatible lead wire ranges is used, or if wires are tightened to not a proper torque, due to it creates a risk of defective contact and other problems.

