

# COMPACT GUIDED CYLINDER SERIES CMPG

The guided compact cylinder series CMPG is a robust and practical solution with a built-in guide unit. The rod guiding bushes are mounted directly in the anodized aluminium alloy lining.

Two guiding solutions are available: sintered bronze bushes coupled with ground carbon chromed steel rods, or ball recirculation bushes coupled with tempered, chromed and ground steel rods.

There are grooves on one side of the body to house the retractable sensors.

In the non-cushioned version, the stop is silenced by NBR front gaskets, and the cushioned version has adjustable pins to graduate braking.

Threaded holes and calibrated holes are provided for fixing the dowel pins.

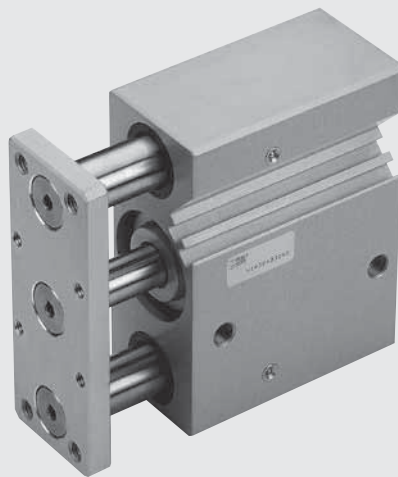

TECHNICAL DATA		CUSHIONED	NO-CUSHIONED
Operating pressure	bar		1 to 10
	MPa		0.1 to 1
	psi		14.5 to 145
	°C		-10 to +80
Temperature range	°C		-10 to +80
	°F		14 to 176
Fluid		Unlubricated air. Lubrication, if used, must be continuous	
Bores	mm	16; 20; 25; 32; 40; 50; 63	16; 20; 25; 32; 40; 50; 63; 80; 100
Strokes	mm	Ø 16: 20 - 30-40-50	Ø 16: 10-20-25-30-40-50-75-100-150-200
		Ø 20; Ø 25: 20-30-40-50-75-100-150	Ø 20; Ø 25: 20-25-30-40-50-75-100-150-200
		Ø 32 to Ø 63: 25-50-75-100-150-175	Ø 32 to Ø 100: 25-50-75-100-150-200
Version		With bronze bushings With ball bearings	
Weights		See cylinder "General technical data" at the beginning of the chapter	

## COMPONENTS

- ① BARREL: anodized aluminium alloy
- ② PISTON ROD: grinded chrome steel
- ③ GUIDE ROD: grinded chrome steel
- ④ GUIDE ROD: hardened and tempered chrome steel
- ⑤ REAR BASE: anodized aluminium alloy
- ⑥ FRONT BASE: anodized aluminium alloy
- ⑦ GUIDE BUSHING: self-lubricating bronze
- ⑨ PISTON: aluminium alloy
- ⑩ MAGNET: plastoferrite
- ⑪ PISTON GASKET: polyurethane
- ⑬ SLIDE BUSHING: sintered bronze
- ⑭ BALL BEARINGS
- ⑮ DUST SCRAPER RING: NBR or FKM/FPM
- ⑯ GREASE NIPPLES: zinc-plated or stainless steel
- ⑰ FLANGE: anodized aluminium alloy

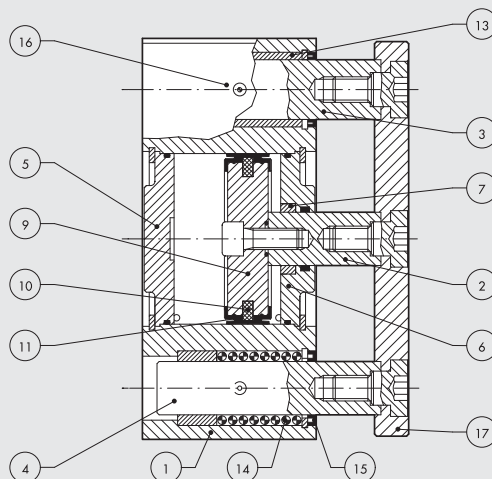

**MAXIMUM SIDE LOAD**

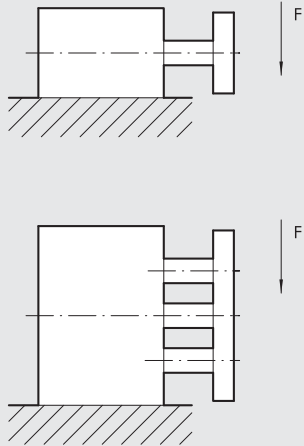

Ø mm	Guide unit	Stroke (mm)										
		10	20	25	30	40	50	75	100	150	175	200
16	Bushes	35	29	27	26	23	20	16	14	10	-	8
	Balls	29	31	-	27	38	34	29	24	12	-	8
20	Bushes	-	52	50	45	39	35	58	49	38	-	31
	Balls	-	56	-	48	79	70	54	50	27	-	32
25	Bushes	-	71	67	61	54	48	78	66	50	-	41
	Balls	-	72	-	62	78	73	60	52	37	-	30
32	Bushes	-	-	197	-	-	168	138	109	78	70	65
	Balls	-	-	89	-	-	60	276	217	138	122	110
40	Bushes	-	-	197	-	-	168	138	109	78	70	65
	Balls	-	-	89	-	-	60	276	217	138	122	110
50	Bushes	-	-	295	-	-	256	216	177	125	112	103
	Balls	-	-	138	-	-	89	393	314	184	163	148
63	Bushes	-	-	295	-	-	256	216	177	125	112	103
	Balls	-	-	138	-	-	89	393	314	184	163	148
80	Bushes	-	-	354	-	-	305	256	207	153	-	128
	Balls	-	-	236	-	-	158	864	687	413	-	335
100	Bushes	-	-	540	-	-	471	413	344	254	-	213
	Balls	-	-	471	-	-	314	1374	1074	629	-	511

N.B.: Forces are expressed in N

**MAXIMUM TORQUE ON PLATE**

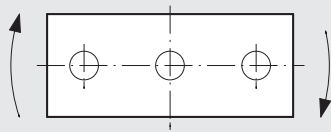

Ø mm	Guide unit	Stroke (mm)										
		10	20	25	30	40	50	75	100	150	175	200
16	Bushes	0.51	0.45	0.40	0.36	0.32	0.28	0.24	0.20	0.46	-	0.12
	Balls	0.74	0.60	-	0.50	0.72	0.65	0.54	0.45	0.35	-	0.25
20	Bushes	-	0.92	0.85	0.79	0.72	0.64	1.05	0.90	0.69	-	0.56
	Balls	-	1.28	-	1.08	1.78	1.59	1.24	1	0.61	-	0.49
25	Bushes	-	1.55	1.42	1.32	1.18	1.04	1.70	1.44	1.10	-	0.90
	Balls	-	1.98	-	1.70	2.16	2.20	1.66	1.4	1.02	-	0.82
32	Bushes	-	-	3.94	-	-	2.95	2.46	1.97	1.55	1.38	1.24
	Balls	-	-	1.97	-	-	1	2.96	2.44	2.40	2.43	2.18
40	Bushes	-	-	4.40	-	-	3.45	2.96	2.46	1.70	1.55	1.40
	Balls	-	-	2.46	-	-	1.45	6.38	5.4	3	2.73	2.40
50	Bushes	-	-	7.36	-	-	5.9	4.90	4.4	3	2.78	2.50
	Balls	-	-	3.45	-	-	2.44	10.8	8.35	4.5	4.06	3.60
63	Bushes	-	-	7.85	-	-	6.38	5.40	4.9	3.4	3.05	2.80
	Balls	-	-	3.94	-	-	2.46	11.77	9.3	5	4.46	4
80	Bushes	-	-	11.78	-	-	9.80	7.84	6.88	5.30	-	4.40
	Balls	-	-	9.34	-	-	5.88	31.38	24.5	10.40	-	11.7
100	Bushes	-	-	22.55	-	-	19.62	16.68	14.7	10.65	-	8.90
	Balls	-	-	21.56	-	-	13.73	63.72	49.1	26.6	-	21.6

N.B.: Forces are expressed in Nm

**ASSEMBLY OPTIONS**

If the compact guided cylinder is mounted as shown in figure A, there need to be two through holes in the frame for the guide columns.

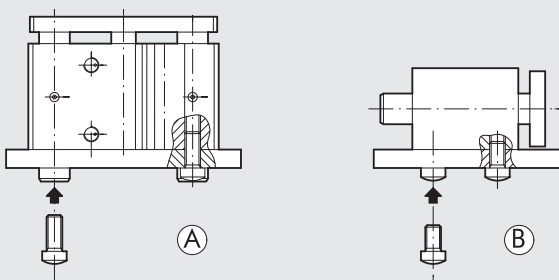

STOPPER FUNCTIONS

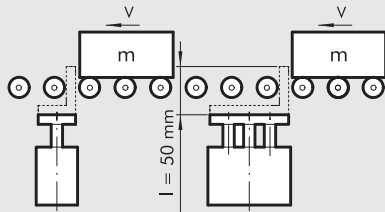

The graph refers to a 50mm-stroke cylinder with bushing guide unit

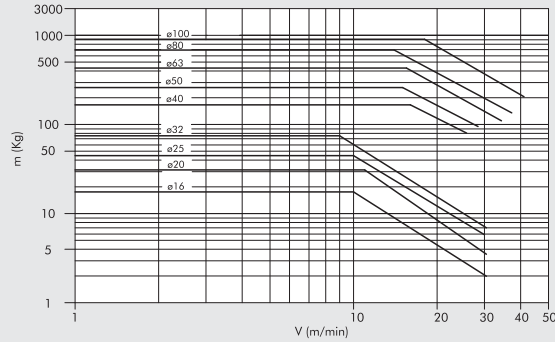

LIFTING FUNCTIONS

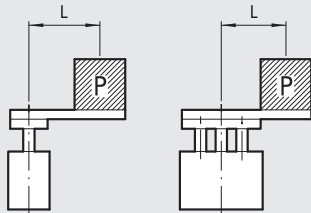

The graph refers from 25 to 50 mm-stroke cylinders with ball re-circulation guide unit

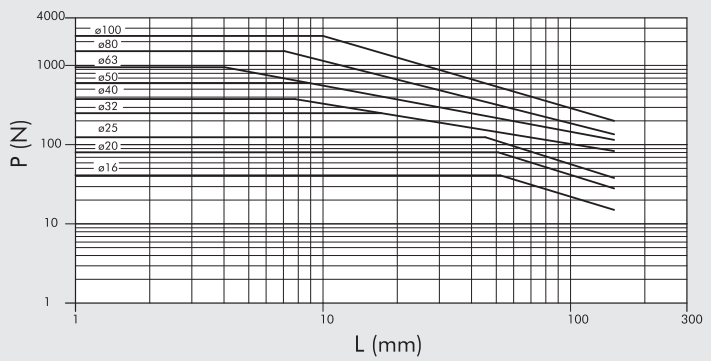

The graph refers from 75 to 100 mm-stroke cylinders with ball re-circulation guide unit

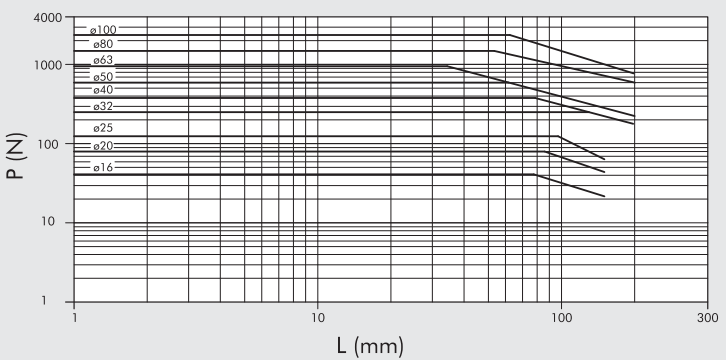

The graph refers to 50 mm-stroke cylinders with bushing guide unit

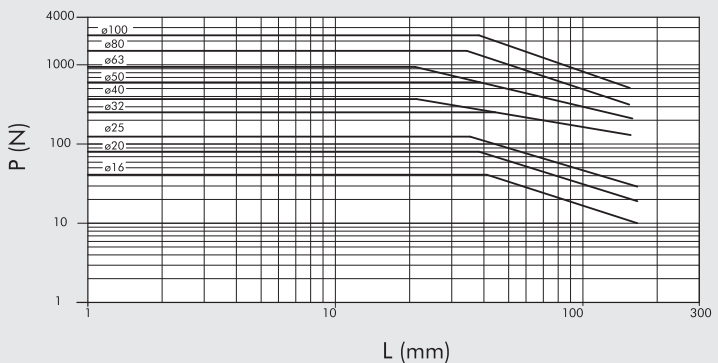

**DIMENSIONS OF NO-CUSHIONED COMPACT GUIDED CYLINDERS**

+ = ADD THE STROKE

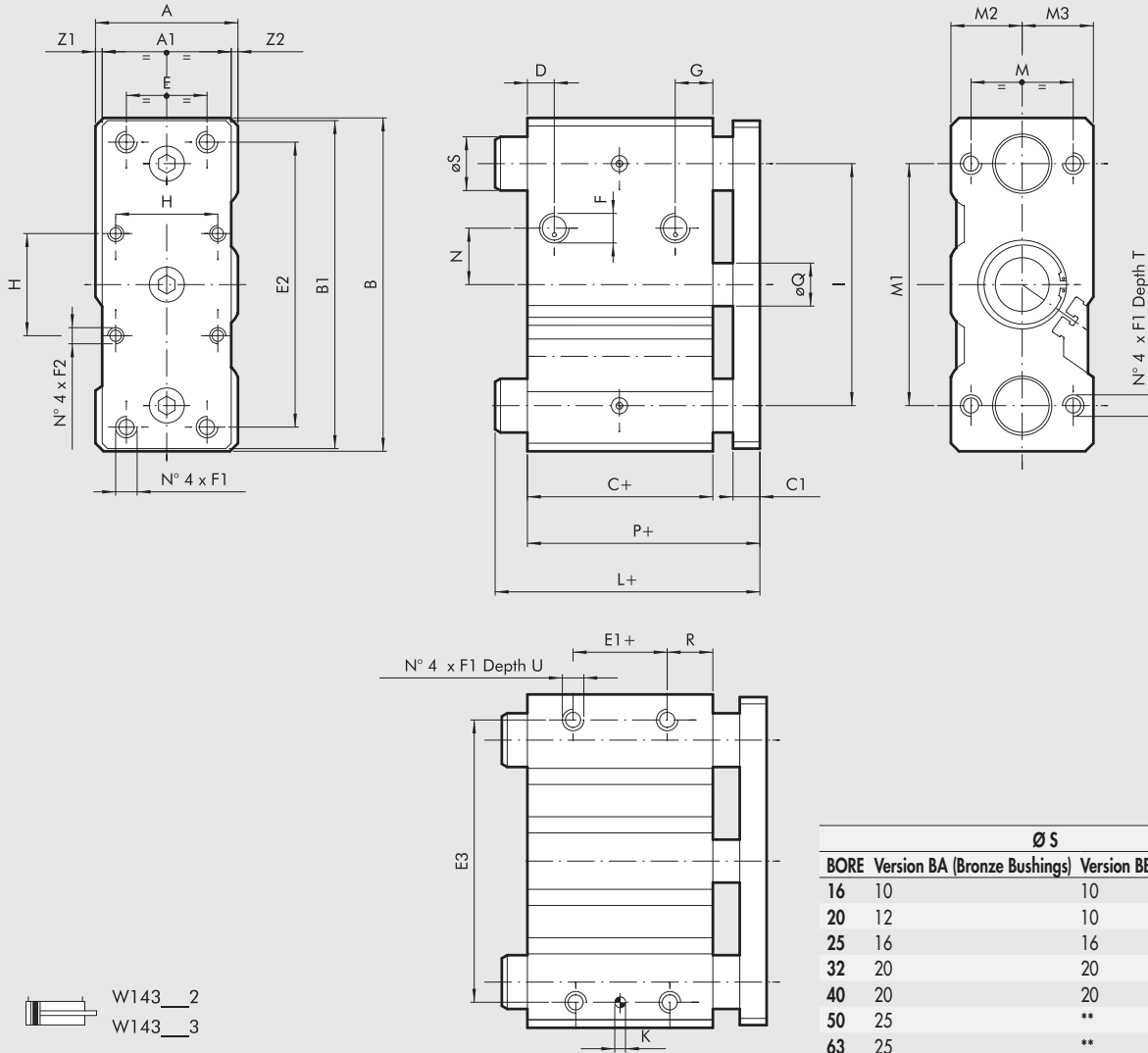

BORE	Ø S	
	Version BA (Bronze Bushings)	Version BB (Ball Bearings)
16	10	10
20	12	10
25	16	16
32	20	20
40	20	20
50	25	**
63	25	**
80	28	25
100	35	30

\*\* for strokes 25 and 50 = 20  
for strokes ≥75 = 25

BORE	stroke	
	0 to 50	75 to 200
16	55	74.5
20	49	79
25	49.5	79.5

Ø	A	A1	B	B1	C	C1	D	E	E1	E2	E3	F	F1	F2	G	H	K <sup>Ø7</sup>	I	L	M	M1	M2	M3	N	P	ØQ	R	T	U	Z1	Z2
16	33	25	64	62	33	10	9	16	7	52	54	M5	M5	-	10.5	-	4	40	*	22	42	15	18	6	46	8	13	20	8	5.5	2.5
20	36	29	74	72	37	10	9	18	10	60	64	1/8 M5	-	-	11	-	5	46	*	26	52	17	19	8	49	10	13	20	8	4.5	2.5
25	42	38	88	86	37.5	10	9	26	10	70	76	1/8 M6	-	-	11.5	-	5	56	*	32	62	21	21	8	49.5	12	14	25	9	2	2
32	51	48	114	112	37.5	10	9	30	5	96	100	1/8 M8	M6	12.5	32.5	6	80	73.5	38	80	25.5	25.5	14	49.5	16	16	20	11	1.5	1.5	
40	51	48	124	122	44	10	11	30	10	106	110	1/8 M8	M6	14	38	6	90	73.5	38	90	25.5	25.5	21	56	16	17	20	11	1.5	1.5	
50	59	56	140	138	44	12	11	40	10	120	124	1/4 M10	M8	14	46.5	6	100	83	44	100	29.5	29.5	27	58	20	17	25	12.5	1.5	1.5	
63	72	69	150	148	49	12	11	50	10	130	132	1/4 M10	M8	14	56.5	6	110	83	44	110	36	36	33	63	20	20	25	15	1.5	1.5	
80	92	88	188	185	56.5	16	15.5	60	15	160	166	3/8 M12	M10	19	72	6	140	93	56	140	46	46	36	74.5	25	21	30	18	2	2	
100	112	108	224	221	66	16	19	80	15	190	200	3/8 M14	M10	23	89	8	170	105	62	170	56	56	40	84	30	25	35	21	2	2	

**DIMENSIONS OF CUSHIONED COMPACT GUIDED CYLINDERS**

+ = ADD THE STROKE

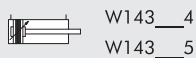
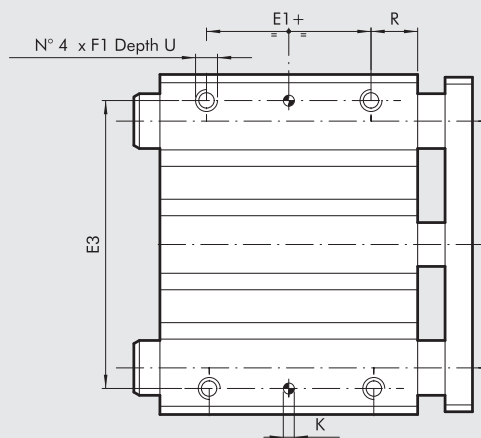
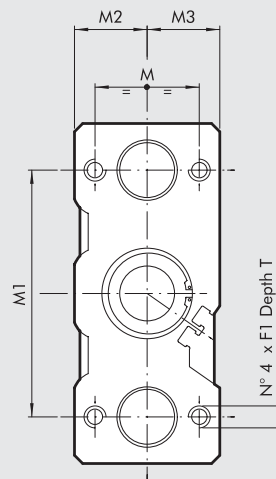
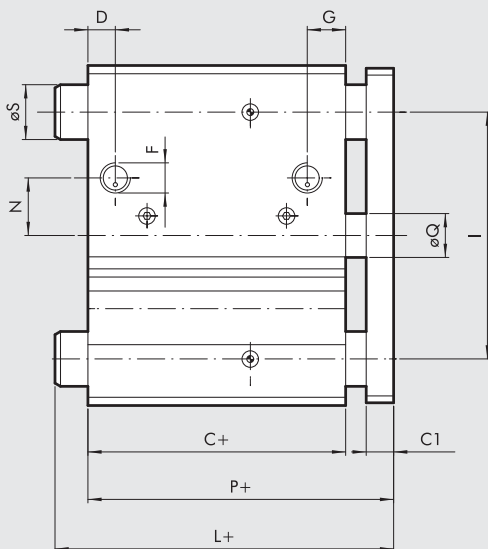
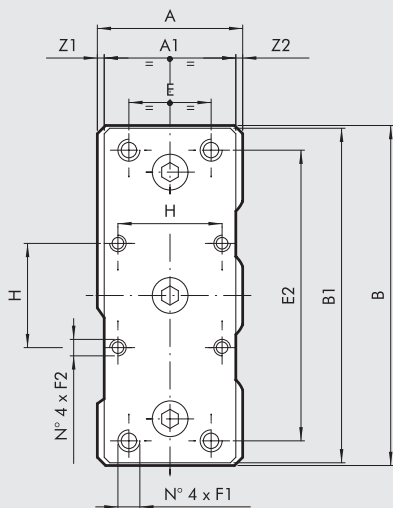

Ø S		
BORE	Version BA (Bronze Bushings)	Version BB (Ball Bearings)
16	10	10
20	12	10
25	16	16
32	20	20
40	20	20
50	25	**
63	25	**

\*\* for strokes 25 and 50 = 20  
for strokes ≥75 = 25

BORE	stroke	
	0 to 50	75 to 200
16	73	-
20	78	105.5
25	78.5	108.5

Ø	A	A1	B	B1	C	C1	D	E	E1	E2	E3	F	F1	F2	G	H	K <sup>17</sup>	I	L	M	M1	M2	M3	N	P	ØQ	R	T	U	Z1	Z2
16	33	25	64	62	58	10	9	16	32	52	54	M5	M5	-	10.5	-	4	40	*	22	42	15	18	8	73	8	13	20	8	5.5	2.5
20	36	29	74	72	62	10	9	18	35	60	64	1/8 M5	-	-	11	-	5	46	*	26	52	16.5	19.5	8.5	78	10	13	20	8	4.5	2.5
25	42	38	88	86	62.5	10	9	26	35	70	76	1/8 M6	-	-	11.5	-	5	56	*	32	62	21	21	13.5	78.5	12	14	25	9	2	2
32	51	48	114	112	62.5	10	9	30	30	96	100	1/8 M8	M6	12.5	32.5	6	80	106.5	38	80	25.5	25.5	15	82.5	16	16.5	20	11	1.5	1.5	
40	51	48	124	122	69	10	11	30	35	106	110	1/8 M8	M6	14	38	6	90	106.5	38	90	25.5	25.5	20.5	89	16	17	20	11	1.5	1.5	
50	59	56	140	138	69	12	11	40	35	120	124	1/4 M10	M8	14	46.5	6	100	118	44	100	29.5	29.5	37	93	20	17	25	12.5	1.5	1.5	
63	72	69	150	148	74	12	11	50	35	130	132	1/4 M10	M8	14	56.5	6	110	118	44	110	36	36	31.5	98	20	20	25	15	1.5	1.5	

**KEY TO CODES**

W 1 4 3 TYPE	0 3 2 DIAMETER	2 VERSION	0 2 5 STROKE
	16 20 25 32 40 50 63 * 80 * A1=100	2 Bronze bushings 3 Ball bearings 4 Cushioned with bronze bushings 5 Cushioned with ball bearings	CUSHIONED VERSION Ø 16: 20, 30, 40, 50 Ø 20 to 25: 20, 30, 40, 50, 75, 100, 150 Ø 32 to 63: 25, 50, 75, 100, 150, 175  NOT CUSHIONED VERSION ♦ Ø 16: 10, 20, 25, 30, 40, 50, 75, 100, 150, 200 Ø 20 to 25: 20, 25, 30, 40, 50, 75, 100, 150, 200 Ø 32 to 100: 25, 50, 75, 100, 150, 200  ♦ Other strokes on request but with the same cylinder dimensions as the standard stroke immediately above.

\* Not cushioned version only

**ACCESSORIES FOR COMPACT GUIDED CYLINDER: MAGNETIC SENSORS**

**RETRACTABLE SENSOR**

**SENSOR, SQUARE TYPE**

Latest generation,  
secure fixing

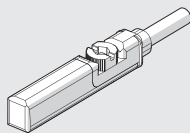

**SENSOR, OVAL TYPE**

Traditional

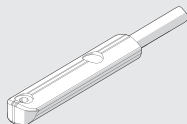

For codes and technical data, see **chapter A6**.

**NOTES**