

Shims for thread-turning tool holder

For inserting into thread-turning tool holder no. 17745-17747

ATORN[®]

Application

For inserting into thread-turning tool holder no. 17745-17747. Sets the thread-turning insert at the correct angle.

Version

- Shims for thread-turning tool holder

Advantage

- Precision-ground for a high degree of dimensional accuracy

Delivery

Shim

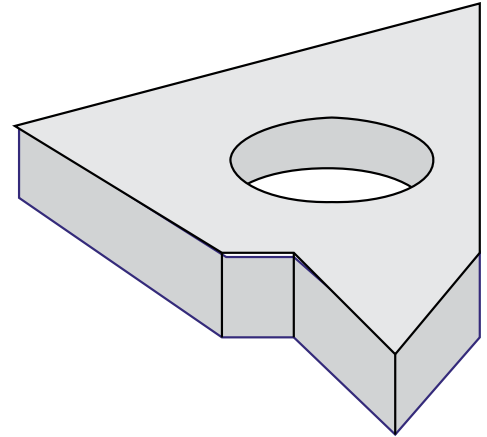

Art. no.	17749 762
Base plate code	AE 16 -0
Resulting pitch angle	0°
Suitable for indexable insert size	16
Suitable for holder	EL/IR

EAN-Code

4050293204766

