

# Ha-VIS eCon 3000

## Full Gigabit Ethernet Basic

### PoE+ 24 V DC/DC



#### 5 to 7 Ethernet Ports RJ45, SC/LC (SFP) and PoE/PoE+ with 24 V DC/DC converter

Unmanaged Plug & Play Ethernet switches for DIN rail assembly in control cabinets

Commercial Temp.: 0 °C ... +55 °C / Industrial Temp.: -40 °C ... +70 °C



- Use of PoE+ with 24 V DC supply (isolated)
- Energy supply of up to 4 terminal devices via PoE+ (137 watts) acc. to IEEE 802.3at
- Full gigabit Ethernet, non-blocking switch architecture acc. to IEEE 802.3
- Support of jumbo frames
- Variants with industrial temperature range of -40°C ... +70 °C
- Surge protection and reverse polarity protection
- Minimum energy consumption due to Energy-Efficient Ethernet
- Optimised DIN rail bracket

#### Target markets

Machinery & Robotics	Automation technology	Industrial network infrastructures
Wind Energy Solar Energy	Transportation	Shipbuilding

## General description

The Ha-VIS eCon 3000 Full Gigabit family of unmanaged Ethernet switches is equipped with up to 7 gigabit Ethernet ports and allow for cost-efficient and quick expansion and/or reconstruction of network infrastructures with high bandwidth requirements. In this, all switches support extra-long Ethernet frames (jumbo frames). The switches work as power sourcing equipment (PSE) and are capable of simultaneously providing the full PoE output of 34.2 watts on up to four ports. Exceeding the PoE+ standard,

the switches are equipped with an integrated, galvanically isolated DC/DC voltage transformer. The switches can be supplied with 24 VDC instead of the usually required 54 VDC. Various combinations of variants with RJ45, fibre optic cables and SFP ports are available. Automatic detection of the transmission rate (auto-negotiation) and of the wiring of the twisted pair data cable (autopolarity and auto-MDI(X)) allow for simple plug & play. All variants are available with the temperature ranges „Industrial“ and „Commercial“.

## Technical characteristics

### Switch Features

Enclosures width	60 mm
Number of ports	5, 6, 7
Switching technology	Store and Forward
Supported standards	IEEE 802.3
Frame Size	10 kbytes
MAC table size	8k entries
Packet buffer size	1 Mbit
Non-blocking	Yes
Quality of service	Yes
Energy-Efficient Ethernet	Yes
PROFINET compatible	Yes
EthernetIP compatible	Yes

### Voltage supply

Nominal voltage	24 VDC $\equiv$
Permissible voltage range	18 VDC ... 60 VDC $\equiv$
Surge protection	Yes
Reverse polarity proof	Yes
Starting current	1.60 A
Overcurrent protection at input	Yes (10 A)
Max. power consumption @ 24 VDC	141,2 W ... 141,6 W
Cross-section / Wire gauge	0.08 mm <sup>2</sup> ... 2.5 mm <sup>2</sup> (28 AWG ... 12 AWG)
Connection type	3-pole, pluggable screwed contact
Pinout	+ / - / $\oplus$
Supply circuit (acc. to 60950)	SELV (circuit breaker 10 A)

### Ethernet Ports 10BASE-T<sub>e</sub> / 100BASE-TX EEE / 1000BASE-T EEE

Connection type	RJ45
Auto-negotiation	Yes
Auto-polarity	Yes
Auto-MDI(X)	Yes
Transfer conditions	Twisted Pair
Transfer speed	10 / 100 / 1000 Mbit/s
Transfer length	100 m (twisted pair, Cat 5)

### Ethernet Ports 1000BASE-SX / 1000BASE-LX

Type of fibre	Multimode (MM)	Singlemode (SM)
Connection type	SC Duplex	
Transfer conditions	FO	
Wavelength	850 nm	1310 nm
Transfer speed	1000 Mbit/s	
Transfer length	0.55 km	10 km
Output power	-9.5 dBm ... -4 dBm	-9.5 dBm ... -3 dBm
Input sensitivity	≤ -17 dBm	≤ -21 dBm

### SFP ports

Transfer standard	Depending on used SFP
Connection type	Depending on used SFP, RJ45 or LC
Transfer conditions	Depending on used SFP, TP or FO
Transfer speed	Depending on used SFP, 100 or 1000 Mbit/s
Transfer length	Depending on used SFP



HARTING Technology Group  
P.O.Box 1473, D-32325 Espelkamp  
Wilhelm-Harting-Straße 1, D-32325 Espelkamp, Germany

ICPN-Service@harting.com | Service hotline: +49 5772 47-9479  
Fax: +49 5772 47-495 | www.HARTING.com/de/ethernet-switches

**Note:** We reserve the right to make technical changes to the products and to the content of this document at any time without prior notification. The HARTING Technologiegruppe does not accept any responsibility for possible errors or incompleteness in this document. We reserve all the rights to this document and the topics and illustrations contained within it. Copying, disclosure to third parties or use of its content - even partially - is forbidden without the prior written consent of the HARTING Technologiegruppe.

PoE	PoE	PoE+
Number of PoE ports	4	
Standard	IEEE 802.3af / IEEE 802.3at	
PoE type	PSE	
Supported mode	Alternative A	
Supply voltage PSE	24 VDC ===	
Max. current consumption PSE	2,6 A	5,7 A
Max. current	375 mA	638 mA
Maximum output power PSE	15.4 W per port 61.6 W total	34.2 W per port 136.8 W total
Supported cabling	See 802.3at, section 33.1.4	
PoE pinout	Alternative A, MDI-X (1/2 = V-, 3/6 = V+)	

#### Status- und Diagnose-Anzeigen

Power („Pwr“) $\Phi$ lights up green	Supply voltage is applied
Link/Activity („L/A“) off	No link
Link/Activity („L/A“) lights up green	Link is active
Link/Activity („L/A“) flashes green	Link is active and data is transferred
Link speed („Spd“) off	10 Mbit/s
Link speed („Spd“) lights up yellow	100 Mbit/s
Link speed („Spd“) lights up green	1000 Mbit/s
PoE status $\Phi$ off	PoE is inactive / low voltage
PoE status $\Phi$ lights up blue	Voltage in PoE+ range
PoE status $\Phi$ lights up red	Error

#### Enclosures

Enclosures width	60 mm
Dimensions H x W x D (without pluggable screw contact and holding bracket)	142 mm x 60 mm x 107.5 mm
Weight	865 g ... 898 g
Type of installation	35 mm DIN rail acc. to EN 60 715
Material enclosures	Anodised aluminium / Powder-coated steel sheet
Protection degree (with plugged screw contact)	IP30
Protection class	III

#### Ambient conditions

Commercial temperature range	0 °C ... +55 °C
Industrial temperature range	-40 °C ... +70 °C
Storage temperature range	-40 °C ... +85 °C
Relative humidity (operation)	0 % ... 95 % (not-condensing)
Relative humidity (storage and transport)	0 % ... 95 % (not-condensing)
Air pressure (operation)	2000 m (795 hPa)

#### Approvals

CE, FCC CFR 47 Part 15, cUL US 508 listed, ABB IIT

#### EMC and environmental conditions

##### EMC Interference immunity (EN 61000-6-1, 61 000-6-2 55024)

Electrostatic discharge (ESD) EN 61 000-4-2  
Electromagnetic field EN 61 000-4-3  
Rapid transients (burst) EN 61 000-4-4  
Surge voltages EN 61 000-4-5  
Conducted interference voltages EN 61 000-4-6

##### EMC Interference emission (EN 61000-6-4, EN 55 032, FCC CFR 47 Part 15)

##### Mechanical stability (EN 60721-3)

IEC 60068-2-6 Vibration  
IEC 60068-2-6 Vibration resonance search  
IEC 60068-2-27 Shock test

#### Included in delivery

- Pluggable screw contact for voltage supply
- Assembly instruction

#### Drawings

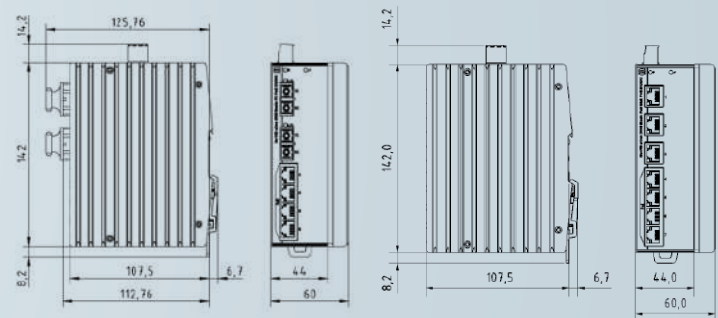

## Technical characteristics / order information

#### Ports / order information

RJ45	SFP	SC	Enclosures width	Current consumption @ 24 VDC with PoE	MTBF in Mio. h	Commercial Temp.: 0 °C ... +55 °C		Industrial Temp.: -40 °C ... +70 °C	
						Switch	Part no.	Switch	Part no.
4	-	1x MM (0.55 km)	60 mm	5.88	0.82	Ha-VIS eCon 3041GB-AD-PP	24 03 504 1130	Ha-VIS eCon 3041GBT-AD-PP	24 03 504 1120
4	-	1x SM (10 km)	60 mm	5.88	0.80	Ha-VIS eCon 3041GB-AF-PP	24 03 504 1230	Ha-VIS eCon 3041GBT-AF-PP	24 03 504 1220
4	-	2x MM (0.55 km)	60 mm	5.90	0.81	Ha-VIS eCon 3042GB-AD-PP	24 03 504 2130	Ha-VIS eCon 3042GBT-AD-PP	24 03 504 2120
4	-	2x SM (10 km)	60 mm	5.90	0.81	Ha-VIS eCon 3042GB-AF-PP	24 03 504 2230	Ha-VIS eCon 3042GBT-AF-PP	24 03 504 2220
4	3	-	60 mm	5.90	0.57	Ha-VIS eCon 3043GB-AC-PP	24 03 504 3330	Ha-VIS eCon 3043GBT-AC-PP	24 03 504 3320
5	-	-	60 mm	5.88	0.80	Ha-VIS eCon 3050GB-A-PP	24 03 505 0030	Ha-VIS eCon 3050GBT-A-PP	24 03 505 0020
5	-	1x MM (0.55 km)	60 mm	5.90	0.79	Ha-VIS eCon 3051GB-AD-PP	24 03 505 1130	Ha-VIS eCon 3051GBT-AD-PP	24 03 505 1120
5	-	1x SM (10 km)	60 mm	5.90	0.79	Ha-VIS eCon 3051GB-AF-PP	24 03 505 1230	Ha-VIS eCon 3051GBT-AF-PP	24 03 505 1220
5	2	-	60 mm	5.90	0.55	Ha-VIS eCon 3052GB-AC-PP	24 03 505 2330	Ha-VIS eCon 3052GBT-AC-PP	24 03 505 2320
6	-	-	60 mm	5.90	0.76	Ha-VIS eCon 3060GB-A-PP	24 03 506 0030	Ha-VIS eCon 3060GBT-A-PP	24 03 506 0020
6	1	-	60 mm	5.90	0.53	Ha-VIS eCon 3061GB-AC-PP	24 03 506 1330	Ha-VIS eCon 3061GBT-AC-PP	24 03 506 1320
7	-	-	60 mm	5.90	0.52	Ha-VIS eCon 3070GB-A-PP	24 03 507 0030	Ha-VIS eCon 3070GBT-A-PP	24 03 507 0020