

"Explosionszeichnung als Referenz, Polzahl siehe description"
 "Exploded drawing for reference, pole count see description"

A3

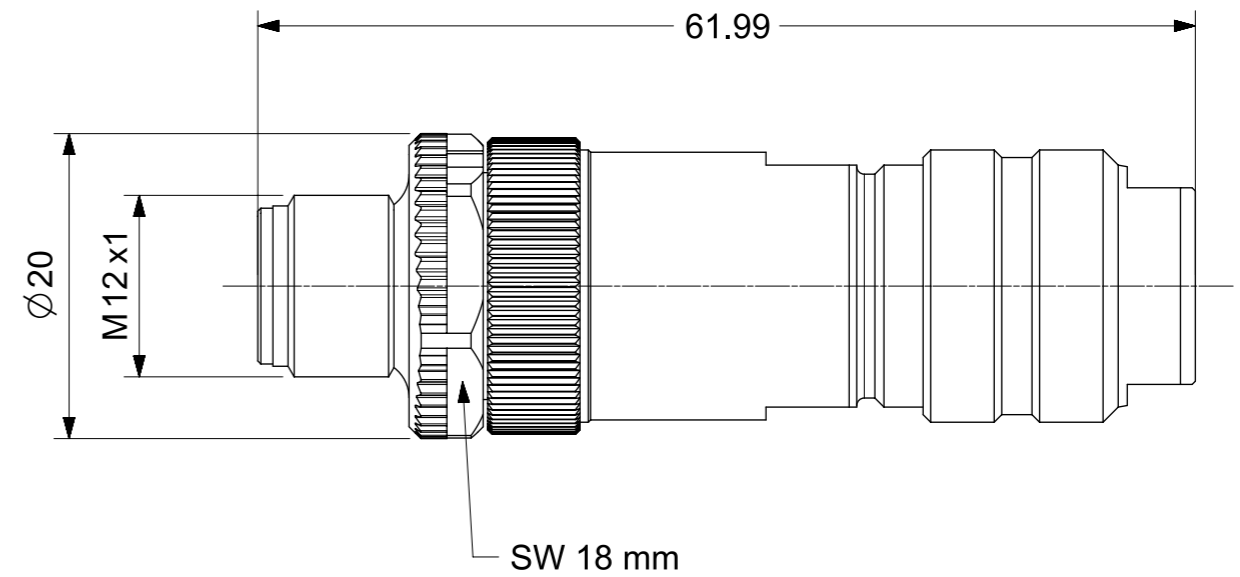
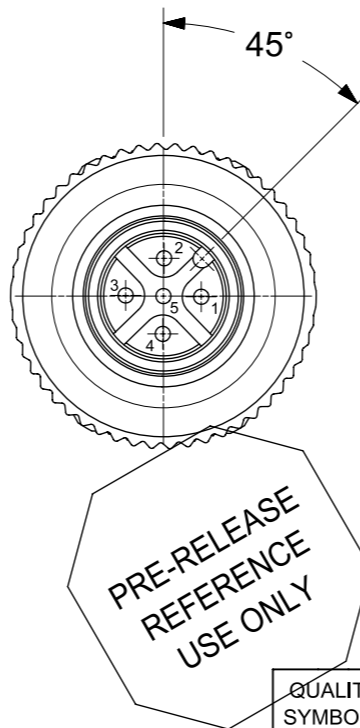
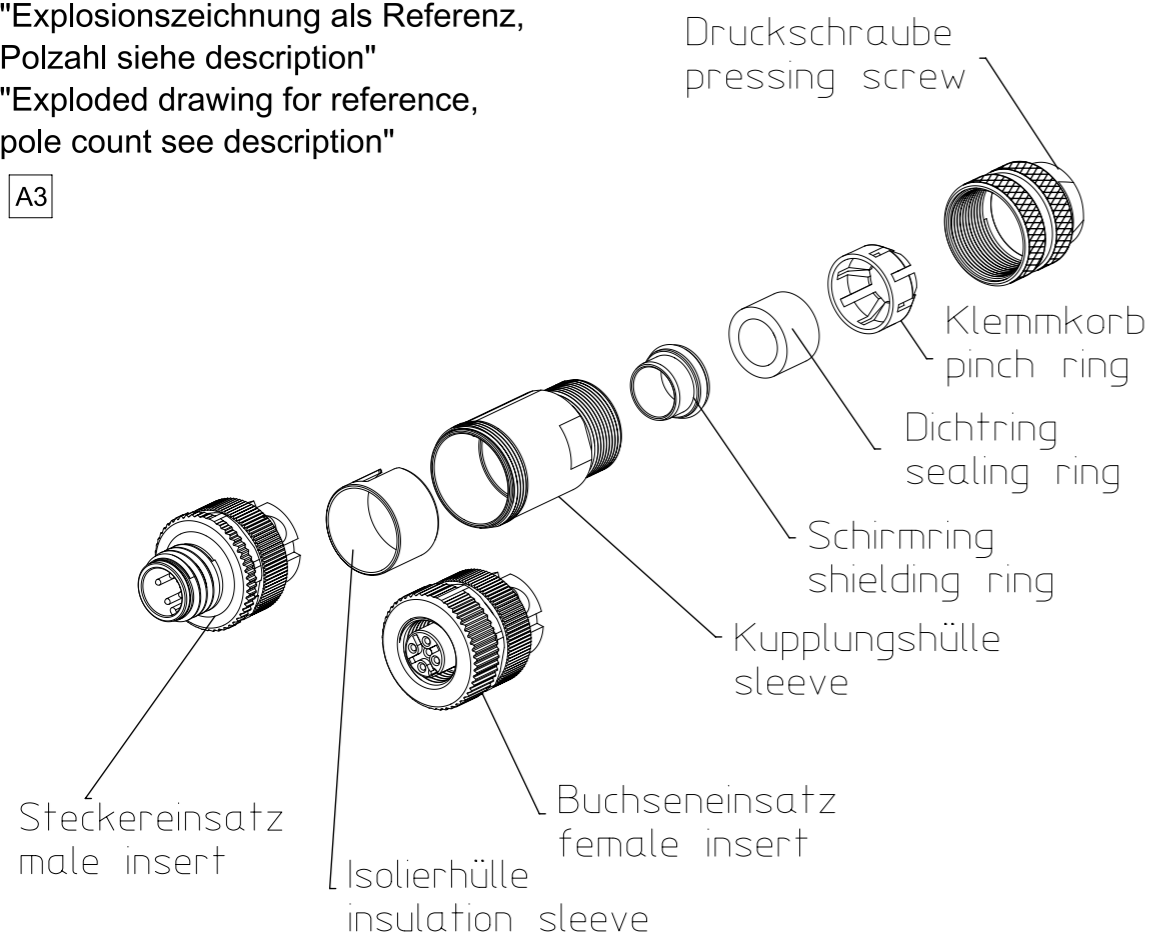

NOTES:

1. LOCKING SYSTEM: SCREW
 WIRE GAUGE: 075mm²
 CABLE OUTLET: 6 - 8mm
2. ELECTRICAL DATA:
 CURRENT RATING: 4A
 VOLTAGE RATING: 60V
3. MECHANICAL:
 OPERATING TEMP.: -40°C to +85°C
 PROTECTION CLASS: IP67
4. MATERIAL:
 CONTACT: CuZn (BRASS)
 CONTACT PLATING: Au (GOLD)
 HOUSING: zinc die cast
 COUPLING NUT: CuZn (BRASS)

ENG.-NO: 8A5S06-32

THIS DRAWING CONTAINS INFORMATION THAT IS PROPRIETARY TO MOLEX ELECTRONIC TECHNOLOGIES, LLC AND SHOULD NOT BE USED WITHOUT WRITTEN PERMISSION

QUALITY SYMBOLS FA = 0 FE = 0 FP = 0 FV = 0 FC = 0 FX = 0 FS = 0 FT = 0	EC NO: 107393 DRWN: LRAMAMURTHY CHK'D: APPR:	2016/08/10 GENERAL TOLERANCES (UNLESS SPECIFIED) ANGULAR TOL ± 1.0 ° 4 PLACES ± 3 PLACES ± 2 PLACES ± 0.05 1 PLACE ± 0.3 0 PLACES ± 0.5 DRAFT WHERE APPLICABLE MUST REMAIN WITHIN DIMENSIONS	DIMENSION UNITS: MM SCALE: 2:1 DRWN BY: MSCHWARZ DATE: 2015/07/01 CHK'D BY: DATE: APPR BY: DATE:	DRAWING SIZE: A3 THIRD ANGLE PROJECTION	FA M12 5P AC MA STR SCR SHLD PRODUCT CUSTOMER DRAWING
	EC NO: 107393 DRWN: LRAMAMURTHY CHK'D: APPR:	2016/08/10 GENERAL TOLERANCES (UNLESS SPECIFIED) ANGULAR TOL ± 1.0 ° 4 PLACES ± 3 PLACES ± 2 PLACES ± 0.05 1 PLACE ± 0.3 0 PLACES ± 0.5 DRAFT WHERE APPLICABLE MUST REMAIN WITHIN DIMENSIONS	DIMENSION UNITS: MM SCALE: 2:1 DRWN BY: MSCHWARZ DATE: 2015/07/01 CHK'D BY: DATE: APPR BY: DATE:	DRAWING SIZE: A3 THIRD ANGLE PROJECTION	FA M12 5P AC MA STR SCR SHLD PRODUCT CUSTOMER DRAWING
	EC NO: 107393 DRWN: LRAMAMURTHY CHK'D: APPR:	2016/08/10 GENERAL TOLERANCES (UNLESS SPECIFIED) ANGULAR TOL ± 1.0 ° 4 PLACES ± 3 PLACES ± 2 PLACES ± 0.05 1 PLACE ± 0.3 0 PLACES ± 0.5 DRAFT WHERE APPLICABLE MUST REMAIN WITHIN DIMENSIONS	DIMENSION UNITS: MM SCALE: 2:1 DRWN BY: MSCHWARZ DATE: 2015/07/01 CHK'D BY: DATE: APPR BY: DATE:	DRAWING SIZE: A3 THIRD ANGLE PROJECTION	FA M12 5P AC MA STR SCR SHLD PRODUCT CUSTOMER DRAWING
	EC NO: 107393 DRWN: LRAMAMURTHY CHK'D: APPR:	2016/08/10 GENERAL TOLERANCES (UNLESS SPECIFIED) ANGULAR TOL ± 1.0 ° 4 PLACES ± 3 PLACES ± 2 PLACES ± 0.05 1 PLACE ± 0.3 0 PLACES ± 0.5 DRAFT WHERE APPLICABLE MUST REMAIN WITHIN DIMENSIONS	DIMENSION UNITS: MM SCALE: 2:1 DRWN BY: MSCHWARZ DATE: 2015/07/01 CHK'D BY: DATE: APPR BY: DATE:	DRAWING SIZE: A3 THIRD ANGLE PROJECTION	FA M12 5P AC MA STR SCR SHLD PRODUCT CUSTOMER DRAWING