



VERY LOW POWER, NEGATIVE RAIL INPUT, RAIL-TO-RAIL OUTPUT, FULLY DIFFERENTIAL AMPLIFIER

 Check for Samples: [THS4521](#), [THS4522](#), [THS4524](#)

FEATURES

- Fully Differential Architecture
- Bandwidth: 145 MHz
- Slew Rate: 490 V/ μ s
- HD₂: –133 dBc at 10 kHz (1 V_{RMS}, R_L = 1 k Ω)
- HD₃: –140 dBc at 10 kHz (1 V_{RMS}, R_L = 1 k Ω)
- Input Voltage Noise: 4.6 nV/ $\sqrt{\text{Hz}}$ (f = 100 kHz)
- THD+N: –112dBc (0.00025%) at 1 kHz (22-kHz BW, G = 1, 5 V_{PP})
- Open-Loop Gain: 119 dB
- NRI—Negative Rail Input
- RRO—Rail-to-Rail Output
- Output Common-Mode Control (with Low Offset and Drift)
- Power Supply:
 - Voltage: +2.5 V (\pm 1.25 V) to +5.5 V (\pm 2.75 V)
 - Current: 1.14 mA/ch
- Power-Down Capability: 20 μ A (typ)

THS4521 and ADS1278 Combined Performance

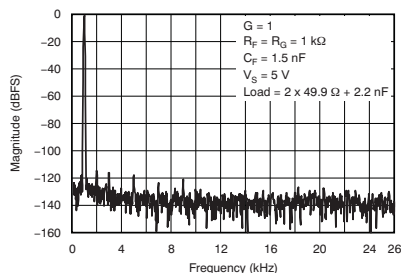
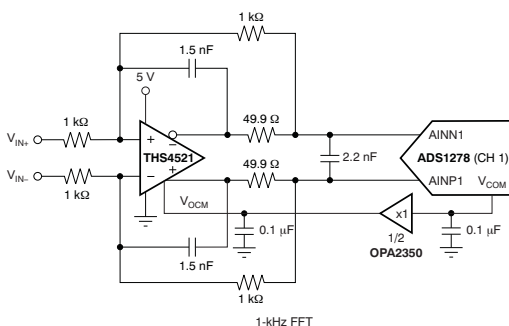

Tone (Hz)	Signal (dBFS)	SNR (dBc)	THD (dBc)	SINAD (dBc)	SFDR (dBc)
1 k	-0.50	109.1	-107.9	105.5	113.7

APPLICATIONS

- Low-Power SAR and $\Delta\Sigma$ ADC Drivers
- Low-Power Differential Drivers
- Low-Power Differential Signal Conditioning
- Low-Power, High-Performance Differential Audio Amplifiers

DESCRIPTION

The THS4521, THS4522, and THS4524 family of devices are very low-power, fully differential op amps with rail-to-rail output and an input common-mode range that includes the negative rail. These amplifiers are designed for low-power data acquisition systems and high-density applications where power dissipation is a critical parameter, and provide exceptional performance in audio applications.

The family includes single (THS4521), dual (THS4522), and quad (THS4524) versions.

These fully differential op amps feature accurate output common-mode control that allows for dc-coupling when driving analog-to-digital converters (ADCs). This control, coupled with an input common-mode range below the negative rail as well as rail-to-rail output, allows for easy interfacing between single-ended, ground-referenced signal sources. Additionally, these devices are ideally suited for driving both successive-approximation register (SAR) and delta-sigma ($\Delta\Sigma$) ADCs using only a single +2.5V to +5V and ground power supply.

The THS4521, THS4522, and THS4524 family of fully differential op amps is characterized for operation over the full industrial temperature range from –40°C to +85°C.

RELATED PRODUCTS

DEVICE	BW (MHz)	I _Q (mA)	THD (dBc) at 100 kHz	V _N (nV/ $\sqrt{\text{Hz}}$)	RAIL-TO-RAIL
THS4520	570	15.3	–114	2	Out
THS4121	100	16	–79	5.4	In/Out
THS4130	150	16	–107	1.3	No



Please be aware that an important notice concerning availability, standard warranty, and use in critical applications of Texas Instruments semiconductor products and disclaimers thereto appears at the end of this data sheet.

I²S is a trademark of NXP Semiconductor.

All other trademarks are the property of their respective owners.



This integrated circuit can be damaged by ESD. Texas Instruments recommends that all integrated circuits be handled with appropriate precautions. Failure to observe proper handling and installation procedures can cause damage.

ESD damage can range from subtle performance degradation to complete device failure. Precision integrated circuits may be more susceptible to damage because very small parametric changes could cause the device not to meet its published specifications.

PACKAGE/ORDERING INFORMATION⁽¹⁾

PRODUCT	PACKAGE-LEAD	PACKAGE DESIGNATOR	SPECIFIED TEMPERATURE RANGE	PACKAGE MARKING	ORDERING NUMBER	TRANSPORT MEDIA, QUANTITY
THS4521	SOIC-8	D	-40°C to +85°C	TH4521	THS4521ID	Rails, 75
					THS4521IDR	Tape and reel, 2500
	MSOP-8	DGK		4521	THS4521IDGKT	Tape and reel, 250
					THS4521IDGKR	Tape and reel, 2500
THS4522	TSSOP-16	PW	-40°C to +85°C	THS4522	THS4522IPW	Rails, 90
					THS4522IPWR	Tape and reel, 2000
THS4524	TSSOP-38	DBT	-40°C to +85°C	THS4524	THS4524IDBT	Rails, 50
					THS4524IDBTR	Tape and reel, 2000

(1) For the most current package and ordering information, see the Package Option Addendum at the end of this document, or see the relevant product folders at www.ti.com.

ABSOLUTE MAXIMUM RATINGS⁽¹⁾

Over operating free-air temperature range (unless otherwise noted).

		THS4521, THS4522, THS4524	UNIT
Supply Voltage, V_{S-} to V_{S+}		5.5	V
Input/Output Voltage, V_I ($V_{IN\pm}$, $V_{OUT\pm}$, V_{OCM} pins)		$(V_{S-}) - 0.7$ to $(V_{S+}) + 0.7V$	V
Differential Input Voltage, V_{ID}		1	V
Output Current, I_O		100	mA
Input Current, I_I ($V_{IN\pm}$, V_{OCM} pins)		10	mA
Continuous Power Dissipation		See Thermal Characteristic Specifications	
Maximum Junction Temperature, T_J		+150	°C
Maximum Junction Temperature, T_J (continuous operation, long-term reliability)		+125	°C
Operating Free-air Temperature Range, T_A		-40 to +85	°C
Storage Temperature Range, T_{STG}		-65 to +150	°C
ESD Rating:	Human Body Model (HBM)	1300	V
	Charge Device Model (CDM)	1000	V
	Machine Model (MM)	50	V

(1) Stresses beyond those listed under *Absolute Maximum Ratings* may cause permanent damage to the device. These are stress ratings only, and functional operation of the device at these or any other conditions beyond those indicated is not implied. Exposure to absolute-maximum-rated conditions for extended periods may affect device reliability.

ELECTRICAL CHARACTERISTICS: $V_{S+} - V_{S-} = 3.3\text{ V}$

At $V_{S+} = +3.3\text{ V}$, $V_{S-} = 0\text{ V}$, $V_{OCM} = \text{open}$, $V_{OUT} = 2\text{ V}_{PP}$ (differential), $R_L = 1\text{ k}\Omega$ differential, $G = 1\text{ V/V}$, single-ended input, differential output, and input and output referenced to midsupply, unless otherwise noted.

PARAMETER	CONDITIONS	THS4521, THS4522, THS4524			UNIT	TEST LEVEL ⁽¹⁾
		MIN	TYP	MAX		
AC PERFORMANCE						
Small-Signal Bandwidth	$V_{OUT} = 100\text{ mV}_{PP}$, $G = 1$		135		MHz	C
	$V_{OUT} = 100\text{ mV}_{PP}$, $G = 2$		49		MHz	C
	$V_{OUT} = 100\text{ mV}_{PP}$, $G = 5$		18.6		MHz	C
	$V_{OUT} = 100\text{ mV}_{PP}$, $G = 10$		9.3		MHz	C
Gain Bandwidth Product	$V_{OUT} = 100\text{ mV}_{PP}$, $G = 10$		93		MHz	C
Large-Signal Bandwidth	$V_{OUT} = 2\text{ V}_{PP}$, $G = 1$		95		MHz	C
Bandwidth for 0.1-dB Flatness	$V_{OUT} = 2\text{ V}_{PP}$, $G = 1$		20		MHz	C
Rising Slew Rate (Differential)	$V_{OUT} = 2\text{-V Step}$, $G = 1$, $R_L = 200\ \Omega$		420		V/ μs	C
Falling Slew Rate (Differential)	$V_{OUT} = 2\text{-V Step}$, $G = 1$, $R_L = 200\ \Omega$		460		V/ μs	C
Overshoot	$V_{OUT} = 2\text{-V Step}$, $G = 1$, $R_L = 200\ \Omega$		1.2		%	C
Undershoot	$V_{OUT} = 2\text{-V Step}$, $G = 1$, $R_L = 200\ \Omega$		2.1		%	C
Rise Time	$V_{OUT} = 2\text{-V Step}$, $G = 1$, $R_L = 200\ \Omega$		4		ns	C
Fall Time	$V_{OUT} = 2\text{-V Step}$, $G = 1$, $R_L = 200\ \Omega$		3.5		ns	C
Settling Time to 1%	$V_{OUT} = 2\text{-V Step}$, $G = 1$, $R_L = 200\ \Omega$		13		ns	C
Harmonic Distortion						
2nd harmonic	$f = 1\text{ kHz}$, $V_{OUT} = 1\text{ V}_{RMS}$, $G = 1$ ⁽²⁾ , differential input		-122		dBc	C
	$f = 1\text{ MHz}$, $V_{OUT} = 2\text{ V}_{PP}$, $G = 1$		-85		dBc	C
3rd harmonic	$f = 1\text{ kHz}$, $V_{OUT} = 1\text{ V}_{RMS}$, $G = 1$ ⁽²⁾ , differential input		-141		dBc	C
	$f = 1\text{ MHz}$, $V_{OUT} = 2\text{ V}_{PP}$, $G = 1$		-90		dBc	C
Second-Order Intermodulation Distortion	Two-tone, $f_1 = 2\text{ MHz}$, $f_2 = 2.2\text{ MHz}$, $V_{OUT} = 2\text{-V}_{PP}$ envelope		-83		dBc	C
Third-Order Intermodulation Distortion	Two-tone, $f_1 = 2\text{ MHz}$, $f_2 = 2.2\text{ MHz}$, $V_{OUT} = 2\text{-V}_{PP}$ envelope		-90		dBc	C
Input Voltage Noise	$f > 10\text{ kHz}$		4.6		nV/ $\sqrt{\text{Hz}}$	C
Input Current Noise	$f > 100\text{ kHz}$		0.6		pA/ $\sqrt{\text{Hz}}$	C
Overdrive Recovery Time	Overdrive = $\pm 0.5\text{ V}$		80		ns	C
Output Balance Error	$V_{OUT} = 100\text{ mV}$, $f \leq 2\text{ MHz}$ (differential input)		-57		dB	C
Closed-Loop Output Impedance	$f = 1\text{ MHz}$ (differential)		0.3		Ω	C
Channel-to-Channel Crosstalk (THS4522, THS4524)	$f = 10\text{ kHz}$, measured differentially		-125		dB	C
DC PERFORMANCE						
Open-Loop Voltage Gain (A_{OL})		100	116		dB	A
Input-Referred Offset Voltage	$T_A = +25^\circ\text{C}$		± 0.2	± 2	mV	A
	$T_A = -40^\circ\text{C}$ to $+85^\circ\text{C}$		± 0.5	± 3.5	mV	B
Input offset voltage drift ⁽³⁾	$T_A = -40^\circ\text{C}$ to $+85^\circ\text{C}$		± 2		$\mu\text{V}/^\circ\text{C}$	C
Input Bias Current	$T_A = +25^\circ\text{C}$		0.65	0.85	μA	B
	$T_A = -40^\circ\text{C}$ to $+85^\circ\text{C}$		0.75	0.95	μA	B
Input bias current drift ⁽³⁾	$T_A = -40^\circ\text{C}$ to $+85^\circ\text{C}$		± 1.75	± 2	nA/ $^\circ\text{C}$	B
Input Offset Current	$T_A = +25^\circ\text{C}$		± 30	± 180	nA	B
	$T_A = -40^\circ\text{C}$ to $+85^\circ\text{C}$		± 30	± 215	nA	B
Input offset current drift ⁽³⁾	$T_A = -40^\circ\text{C}$ to $+85^\circ\text{C}$		± 100	± 600	pA/ $^\circ\text{C}$	B

(1) Test levels: **(A)** 100% tested at $+25^\circ\text{C}$. Over temperature limits set by characterization and simulation. **(B)** Limits set by characterization and simulation. **(C)** Typical value only for information.

(2) Not directly measurable; calculated using noise gain of 101 as described in the Applications section, [Audio Performance](#).

(3) Input Offset Voltage Drift, Input Bias Current Drift, and Input Offset Current Drift are average values calculated by taking data at -40°C and $+85^\circ\text{C}$, computing the difference, and dividing by 125.

ELECTRICAL CHARACTERISTICS: $V_{S+} - V_{S-} = 3.3\text{ V}$ (continued)

At $V_{S+} = +3.3\text{ V}$, $V_{S-} = 0\text{ V}$, $V_{OCM} = \text{open}$, $V_{OUT} = 2 V_{PP}$ (differential), $R_L = 1\text{ k}\Omega$ differential, $G = 1\text{ V/V}$, single-ended input, differential output, and input and output referenced to midsupply, unless otherwise noted.

PARAMETER	CONDITIONS	THS4521, THS4522, THS4524			UNIT	TEST LEVEL ⁽¹⁾
		MIN	TYP	MAX		
INPUT						
Common-Mode Input Voltage Low	$T_A = +25^\circ\text{C}$		-0.2	-0.1	V	A
	$T_A = -40^\circ\text{C to } +85^\circ\text{C}$		-0.1	0	V	B
Common-Mode Input Voltage High	$T_A = +25^\circ\text{C}$	1.9	2		V	A
	$T_A = -40^\circ\text{C to } +85^\circ\text{C}$	1.8	1.9		V	B
Common-Mode Rejection Ratio (CMRR)		80	100		dB	A
Input Resistance			110 1.5		k Ω pF	C
OUTPUT						
Output Voltage Low	$T_A = +25^\circ\text{C}$		0.08	0.15	V	A
	$T_A = -40^\circ\text{C to } +85^\circ\text{C}$		0.09	0.2	V	B
Output Voltage High	$T_A = +25^\circ\text{C}$	3.0	3.1		V	A
	$T_A = -40^\circ\text{C to } +85^\circ\text{C}$	2.95	3.05		V	B
Output Current Drive (for linear operation)	$R_L = 50\ \Omega$		± 35		mA	C
POWER SUPPLY						
Specified Operating Voltage		2.5		5.5	V	B
Quiescent Operating Current, per channel	$T_A = +25^\circ\text{C}$	0.9	1.0	1.2	mA	A
	$T_A = -40^\circ\text{C to } +85^\circ\text{C}$	0.85	1.0	1.25	mA	B
Power-Supply Rejection Ratio (\pm PSRR)		80	100		dB	A
POWER DOWN						
Enable Voltage Threshold	Assured on above 2.1 V		1.6	2.1	V	A
Disable Voltage Threshold	Assured off below 0.7 V	0.7	1.6		V	A
Disable Pin Bias Current			1		μA	C
Power Down Quiescent Current			10		μA	C
Turn-On Time Delay	Time to $V_{OUT} = 90\%$ of final value, $V_{IN} = 2\text{ V}$, $R_L = 200\ \Omega$		108		ns	B
Turn-Off Time Delay	Time to $V_{OUT} = 10\%$ of original value, $V_{IN} = 2\text{ V}$, $R_L = 200\ \Omega$		88		ns	B
V_{OCM} VOLTAGE CONTROL						
Small-Signal Bandwidth			23		MHz	C
Slew Rate			55		V/ μs	C
Gain		0.98	0.99	1.02	V/V	A
Common-Mode Offset Voltage from V_{OCM} Input	Measured at V_{OUT} with V_{OCM} input driven, $V_{OCM} = 1.65\text{ V} \pm 0.5\text{ V}$		± 2.5	± 4	mV	B
Input Bias Current	$V_{OCM} = 1.65\text{ V} \pm 0.5\text{ V}$		± 5	± 8	μA	B
V_{OCM} Voltage Range		1	0.8 to 2.5	2.3	V	A
Input Impedance			72 1.5		k Ω pF	C
Default Output Common-Mode Voltage Offset from $(V_{S+} - V_{S-})/2$	Measured at V_{OUT} with V_{OCM} input open		± 1.5	± 5	mV	A
THERMAL CHARACTERISTICS						
Specified Operating Range, All Packages			-40 to +85		$^\circ\text{C}$	C
Thermal Resistance, θ_{JA}	Junction-to-ambient					
THS4521	D SO-8		194		$^\circ\text{C/W}$	C
	DGK MSOP-8		269		$^\circ\text{C/W}$	C
THS4522	PW TSSOP-16		116		$^\circ\text{C/W}$	C
THS4524	DBT TSSOP-38		81		$^\circ\text{C/W}$	C

ELECTRICAL CHARACTERISTICS: $V_{S+} - V_{S-} = 5\text{ V}$

At $V_{S+} = +5\text{ V}$, $V_{S-} = 0\text{ V}$, $V_{OCM} = \text{open}$, $V_{OUT} = 2\text{ V}_{PP}$ (differential), $R_F = 1\text{ k}\Omega$, $R_L = 1\text{ k}\Omega$ differential, $G = 1\text{ V/V}$, single-ended input, differential output, input and output referenced to midsupply, unless otherwise noted.

PARAMETER	CONDITIONS	THS4521, THS4522, THS4524			UNIT	TEST LEVEL ⁽¹⁾
		MIN	TYP	MAX		
AC PERFORMANCE						
Small-Signal Bandwidth	$V_{OUT} = 100\text{ mV}_{PP}$, $G = 1$		145		MHz	C
	$V_{OUT} = 100\text{ mV}_{PP}$, $G = 2$		50		MHz	C
	$V_{OUT} = 100\text{ mV}_{PP}$, $G = 5$		20		MHz	C
	$V_{OUT} = 100\text{ mV}_{PP}$, $G = 10$		9.5		MHz	C
Gain Bandwidth Product	$V_{OUT} = 100\text{ mV}_{PP}$, $G = 10$		95		MHz	C
Large-Signal Bandwidth	$V_{OUT} = 2\text{ V}_{PP}$, $G = 1$		145		MHz	C
Bandwidth for 0.1-dB Flatness	$V_{OUT} = 2\text{ V}_{PP}$, $G = 1$		30		MHz	C
Rising Slew Rate (Differential)	$V_{OUT} = 2\text{-V Step}$, $G = 1$, $R_L = 200\ \Omega$		490		V/ μs	C
Falling Slew Rate (Differential)	$V_{OUT} = 2\text{-V Step}$, $G = 1$, $R_L = 200\ \Omega$		600		V/ μs	C
Overshoot	$V_{OUT} = 2\text{-V Step}$, $G = 1$, $R_L = 200\ \Omega$		1		%	C
Undershoot	$V_{OUT} = 2\text{-V Step}$, $G = 1$, $R_L = 200\ \Omega$		2.6		%	C
Rise Time	$V_{OUT} = 2\text{-V Step}$, $G = 1$, $R_L = 200\ \Omega$		3.4		ns	C
Fall Time	$V_{OUT} = 2\text{-V Step}$, $G = 1$, $R_L = 200\ \Omega$		3		ns	C
Settling Time to 1%	$V_{OUT} = 2\text{-V Step}$, $G = 1$, $R_L = 200\ \Omega$		10		ns	C
Harmonic Distortion						
2nd harmonic	$f = 1\text{ kHz}$, $V_{OUT} = 1\text{ V}_{RMS}$, $G = 1^{(2)}$, differential input		-122		dBc	C
	$f = 1\text{ MHz}$, $V_{OUT} = 2\text{ V}_{PP}$, $G = 1$		-85		dBc	C
3rd harmonic	$f = 1\text{ kHz}$, $V_{OUT} = 1\text{ V}_{RMS}$, $G = 1^{(2)}$, differential input		-141		dBc	C
	$f = 1\text{ MHz}$, $V_{OUT} = 2\text{ V}_{PP}$, $G = 1$		-91		dBc	C
Second-Order Intermodulation Distortion	Two-tone, $f_1 = 2\text{ MHz}$, $f_2 = 2.2\text{ MHz}$, $V_{OUT} = 2\text{-V}_{PP}$ envelope		-86		dBc	C
Third-Order Intermodulation Distortion	Two-tone, $f_1 = 2\text{ MHz}$, $f_2 = 2.2\text{ MHz}$, $V_{OUT} = 2\text{-V}_{PP}$ envelope		-93		dBc	C
Input Voltage Noise	$f > 10\text{ kHz}$		4.6		nV/ $\sqrt{\text{Hz}}$	C
Input Current Noise	$f > 100\text{ kHz}$		0.6		pA/ $\sqrt{\text{Hz}}$	C
SNR	$V_{OUT} = 5\text{ V}_{PP}$, 20 Hz to 22 kHz BW, differential input		114		dBc	C
THD+N	$f = 1\text{ kHz}$, $V_{OUT} = 5\text{ V}_{PP}$, 20 Hz to 22 kHz BW, differential input		112		dBc	C
Overdrive Recovery Time	Overdrive = $\pm 0.5\text{ V}$		75		ns	C
Output Balance Error	$V_{OUT} = 100\text{ mV}$, $f < 2\text{ MHz}$, V_{IN} differential		-57		dB	C
Closed-Loop Output Impedance	$f = 1\text{ MHz}$ (differential)		0.3		Ω	C
Channel-to-Channel Crosstalk (THS4522, THS4524)	$f = 10\text{ kHz}$, measured differentially		-125		dB	C
DC PERFORMANCE						
Open-Loop Voltage Gain (A_{OL})		100	119		dB	A
Input-Referred Offset Voltage	$T_A = +25^\circ\text{C}$		± 0.24	± 2	mV	A
	$T_A = -40^\circ\text{C}$ to $+85^\circ\text{C}$		± 0.5	± 3.5	mV	B
Input offset voltage drift ⁽³⁾	$T_A = -40^\circ\text{C}$ to $+85^\circ\text{C}$		± 2		$\mu\text{V}/^\circ\text{C}$	C
Input Bias Current	$T_A = +25^\circ\text{C}$		0.7	0.9	μA	B
	$T_A = -40^\circ\text{C}$ to $+85^\circ\text{C}$		0.9	1.1	μA	B
Input bias current drift ⁽³⁾	$T_A = -40^\circ\text{C}$ to $+85^\circ\text{C}$		± 1.8	± 2.2	nA/ $^\circ\text{C}$	B

(1) Test levels: **(A)** 100% tested at $+25^\circ\text{C}$. Over temperature limits set by characterization and simulation. **(B)** Limits set by characterization and simulation. **(C)** Typical value only for information.

(2) Not directly measurable; calculated using noise gain of 101 as described in the Applications section, [Audio Performance](#).

(3) Input Offset Voltage Drift, Input Bias Current Drift, and Input Offset Current Drift are average values calculated by taking data at -40°C and $+85^\circ\text{C}$, computing the difference, and dividing by 125.

ELECTRICAL CHARACTERISTICS: $V_{S+} - V_{S-} = 5\text{ V}$ (continued)

At $V_{S+} = +5\text{ V}$, $V_{S-} = 0\text{ V}$, $V_{OCM} = \text{open}$, $V_{OUT} = 2\text{ V}_{PP}$ (differential), $R_F = 1\text{ k}\Omega$, $R_L = 1\text{ k}\Omega$ differential, $G = 1\text{ V/V}$, single-ended input, differential output, input and output referenced to midsupply, unless otherwise noted.

PARAMETER	CONDITIONS	THS4521, THS4522, THS4524			UNIT	TEST LEVEL ⁽¹⁾
		MIN	TYP	MAX		
Input Offset Current	$T_A = +25^\circ\text{C}$		± 30	± 180	nA	B
	$T_A = -40^\circ\text{C}$ to $+85^\circ\text{C}$		± 30	± 215	nA	B
Input offset current drift ⁽⁴⁾	$T_A = -40^\circ\text{C}$ to $+85^\circ\text{C}$		± 100	± 600	pA/°C	B
INPUT						
Common-Mode Input Voltage Low	$T_A = +25^\circ\text{C}$		-0.2	-0.1	V	A
	$T_A = -40^\circ\text{C}$ to $+85^\circ\text{C}$		-0.1	0	V	B
Common-Mode Input Voltage High	$T_A = +25^\circ\text{C}$	3.6	3.7		V	A
	$T_A = -40^\circ\text{C}$ to $+85^\circ\text{C}$	3.5	3.6		V	B
Common-Mode Rejection Ratio (CMRR)		80	102		dB	A
Input Impedance			100 0.7		k pF	C
OUTPUT						
Output Voltage Low	$T_A = +25^\circ\text{C}$		0.10	0.15	V	A
	$T_A = -40^\circ\text{C}$ to $+85^\circ\text{C}$		0.115	0.2	V	B
Output Voltage High	$T_A = +25^\circ\text{C}$	4.7	4.75		V	A
	$T_A = -40^\circ\text{C}$ to $+85^\circ\text{C}$	4.65	4.7		V	B
Output Current Drive (for linear operation)	$R_L = 50\ \Omega$		± 55		mA	C
POWER SUPPLY						
Specified Operating Voltage		2.5		5.5	V	B
Quiescent Operating Current, per channel	$T_A = +25^\circ\text{C}$	0.95	1.14	1.25	mA	A
	$T_A = -40^\circ\text{C}$ to $+85^\circ\text{C}$	0.9	1.15	1.3	mA	B
Power-Supply Rejection Ratio ($\pm\text{PSRR}$)		80	100		dB	A
POWER DOWN						
Enable Voltage Threshold	Ensured on above 2.1 V		1.6	2.1	V	A
Disable Voltage Threshold	Ensured off below 0.7 V	0.7	1.6		V	A
Disable Pin Bias Current			1		μA	C
Power Down Quiescent Current			20		μA	C
Turn-On Time Delay	Time to $V_{OUT} = 90\%$ of final value, $V_{IN} = 2\text{ V}$, $R_L = 200\ \Omega$		70		ns	B
Turn-Off Time Delay	Time to $V_{OUT} = 10\%$ of original value, $V_{IN} = 2\text{ V}$, $R_L = 200\ \Omega$		60		ns	B
V_{OCM} VOLTAGE CONTROL						
Small-Signal Bandwidth			23		MHz	C
Slew Rate			55		V/ μs	C
Gain		0.98	0.99	1.02	V/V	A
Common-Mode Offset Voltage from V_{OCM} Input	Measured at V_{OUT} with V_{OCM} input driven, $V_{OCM} = 2.5\text{ V} \pm 1\text{ V}$		± 5	± 9	mV	B
Input Bias Current	$V_{OCM} = 2.5\text{ V} \pm 1\text{ V}$		± 20	± 25	μA	B
V_{OCM} Voltage Range		1	0.8 to 4.2	4	V	A
Input Impedance			46 1.5		k pF	C
Default Output Common-Mode Voltage Offset from $(V_{S+} - V_{S-})/2$	Measured at V_{OUT} with V_{OCM} input open		± 1	± 5	mV	A
THERMAL CHARACTERISTICS						
Specified Operating Range All Packages		-40		+85	°C	C
Thermal Resistance, θ_{JA}	Junction-to-ambient					
THS4521	D SO-8		194		°C/W	C
	DGK MSOP-8		269		°C/W	C
THS4522	PW TSSOP-16		116		°C/W	C
THS4524	DBT TSSOP-38		81		°C/W	C

(4) Input Offset Voltage Drift, Input Bias Current Drift, and Input Offset Current Drift are average values calculated by taking data at -40°C and $+85^\circ\text{C}$, computing the difference, and dividing by 125.

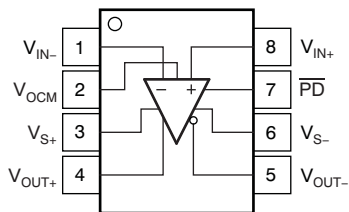
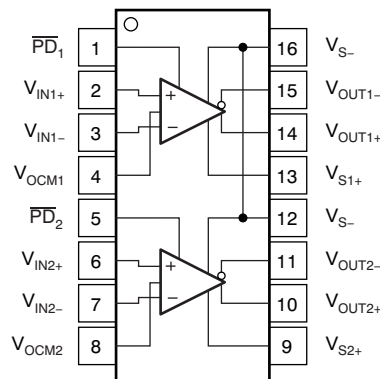
DEVICE INFORMATION
**THS4521
SOIC-8, MSOP-8 (D, DGK PACKAGES)
(TOP VIEW)**

**THS4522
TSSOP-16 (PW PACKAGE)
(TOP VIEW)**

TERMINAL FUNCTIONS: THS4521

SOIC-8, MSOP-8		DESCRIPTION
PIN NO.	NAME	
1	V_{IN-}	Inverting amplifier input
2	V_{OCM}	Common-mode voltage input
3	V_{S+}	Amplifier positive power-supply input
4	V_{OUT+}	Noninverting amplifier output
5	V_{OUT-}	Inverting amplifier output
6	V_{S-}	Amplifier negative power-supply input. Note that V_{S-} is tied together on multi-channel devices.
7	\overline{PD}	Power down. \overline{PD} = logic low puts device into low-power mode. \overline{PD} = logic high or open for normal operation.
8	V_{IN+}	Noninverting amplifier input

TERMINAL FUNCTIONS: THS4522

TSSOP-16		DESCRIPTION
PIN NO.	NAME	
1	\overline{PD}_1	Power down 1. \overline{PD} = logic low puts device into low-power mode. \overline{PD} = logic high or open for normal operation.
2	V_{IN1+}	Noninverting amplifier 1 input
3	V_{IN1-}	Inverting amplifier 1 input
4	V_{OCM1}	Common-mode voltage input 1
5	\overline{PD}_2	Power down 2. \overline{PD} = logic low puts device into low-power mode. \overline{PD} = logic high or open for normal operation.
6	V_{IN2+}	Noninverting amplifier 2 input
7	V_{IN2-}	Inverting amplifier 2 input
8	V_{OCM2}	Common-mode voltage input 2
9	V_{S+2}	Amplifier 2 positive power-supply input
10	V_{OUT2+}	Noninverting amplifier 2 output
11	V_{OUT2-}	Inverting amplifier 2 output
12	V_{S-}	Negative power-supply input. Note that V_{S-} is tied together on multi-channel devices.
13	V_{S+1}	Amplifier 1 positive power-supply input
14	V_{OUT1+}	Noninverting amplifier 1 output
15	V_{OUT1-}	Inverting amplifier 1 output

TERMINAL FUNCTIONS: THS4522 (continued)

TSSOP-16		DESCRIPTION
PIN NO.	NAME	
16	V_{S-}	Negative power-supply input. Note that V_{S-} is tied together on multi-channel devices.

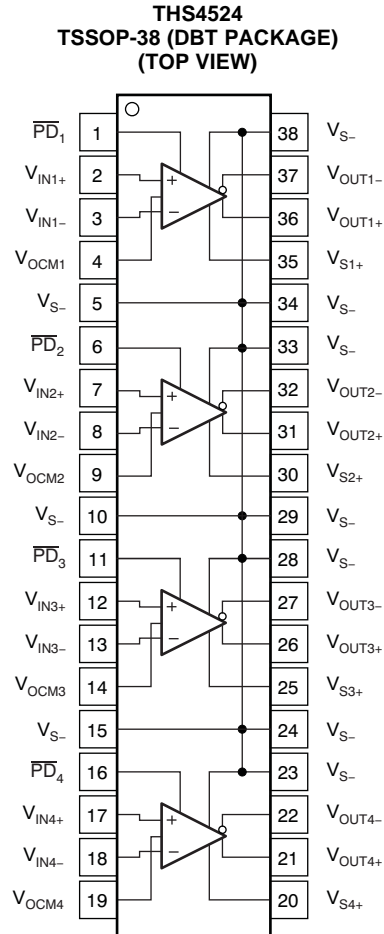

TERMINAL FUNCTIONS: THS4524

TSSOP-38		DESCRIPTION
PIN NO.	NAME	
1	$\overline{\text{PD}}_1$	Power down 1. $\overline{\text{PD}}$ = logic low puts channel into low-power mode. $\overline{\text{PD}}$ = logic high or open for normal operation.
2	$V_{\text{IN}1+}$	Noninverting amplifier 1 input
3	$V_{\text{IN}1-}$	Inverting amplifier 1 input
4	$V_{\text{OCM}1}$	Common-mode voltage input 1
5	$V_{\text{S}-}$	Negative power-supply input. Note that $V_{\text{S}-}$ is tied together on multi-channel devices.
6	$\overline{\text{PD}}_2$	Power down 2. $\overline{\text{PD}}$ = logic low puts channel into low-power mode. $\overline{\text{PD}}$ = logic high or open for normal operation.
7	$V_{\text{IN}2+}$	Noninverting amplifier 2 input
8	$V_{\text{IN}2-}$	Inverting amplifier 2 input
9	$V_{\text{OCM}2}$	Common-mode voltage input 2
10	$V_{\text{S}-}$	Negative power-supply input. Note that $V_{\text{S}-}$ is tied together on multi-channel devices.
11	$\overline{\text{PD}}_3$	Power down 3. $\overline{\text{PD}}$ = logic low puts channel into low-power mode. $\overline{\text{PD}}$ = logic high or open for normal operation.
12	$V_{\text{IN}3+}$	Noninverting amplifier 3 input
13	$V_{\text{IN}3-}$	Inverting amplifier 3 input
14	$V_{\text{OCM}3}$	Common-mode voltage input 3
15	$V_{\text{S}-}$	Negative power-supply input. Note that $V_{\text{S}-}$ is tied together on multi-channel devices.
16	$\overline{\text{PD}}_4$	Power down 4. $\overline{\text{PD}}$ = logic low puts channel into low-power mode. $\overline{\text{PD}}$ = logic high or open for normal operation.
17	$V_{\text{IN}4+}$	Noninverting amplifier 4 input
18	$V_{\text{IN}4-}$	Inverting amplifier 4 input
19	$V_{\text{OCM}4}$	Common-mode voltage input 4
20	$V_{\text{S}4+}$	Amplifier 4 positive power-supply input
21	$V_{\text{OUT}4+}$	Noninverting amplifier 4 output
22	$V_{\text{OUT}4-}$	Inverting amplifier 4 output
23	$V_{\text{S}-}$	Negative power-supply input. Note that $V_{\text{S}-}$ is tied together on multi-channel devices.
24	$V_{\text{S}-}$	Negative power-supply input. Note that $V_{\text{S}-}$ is tied together on multi-channel devices.
25	$V_{\text{S}3+}$	Amplifier 3 positive power-supply input
26	$V_{\text{OUT}3+}$	Noninverting amplifier3 output
27	$V_{\text{OUT}3-}$	Inverting amplifier3 output
28	$V_{\text{S}-}$	Negative power-supply input. Note that $V_{\text{S}-}$ is tied together on multi-channel devices.
29	$V_{\text{S}-}$	Negative power-supply input. Note that $V_{\text{S}-}$ is tied together on multi-channel devices.
30	$V_{\text{S}2+}$	Amplifier 2 positive power-supply input
31	$V_{\text{OUT}2+}$	Noninverting amplifier 2 output
32	$V_{\text{OUT}2-}$	Inverting amplifier 2 output
33	$V_{\text{S}-}$	Negative power-supply input. Note that $V_{\text{S}-}$ is tied together on multi-channel devices.
34	$V_{\text{S}-}$	Negative power-supply input. Note that $V_{\text{S}-}$ is tied together on multi-channel devices.
35	$V_{\text{S}1+}$	Amplifier 1 positive power-supply input
36	$V_{\text{OUT}1+}$	Noninverting amplifier 1 output
37	$V_{\text{OUT}1-}$	Inverting amplifier 1 output
38	$V_{\text{S}-}$	Negative power-supply input. Note that $V_{\text{S}-}$ is tied together on multi-channel devices.

TYPICAL CHARACTERISTICS

Table of Graphs: $V_{S+} - V_{S-} = 3.3\text{ V}$

TITLE	FIGURE
Small-Signal Frequency Response	Figure 1
Large-Signal Frequency Response	Figure 2
Large- and Small-Signal Pulse Response	Figure 3
Slew Rate vs V_{OUT} Step	Figure 4
Overdrive Recovery	Figure 5
10-kHz Output Spectrum on AP Analyzer	Figure 6
Harmonic Distortion vs Frequency	Figure 7
Harmonic Distortion vs Output Voltage at 1 MHz	Figure 8
Harmonic Distortion vs Gain at 1 MHz	Figure 9
Harmonic Distortion vs Load at 1 MHz	Figure 10
Harmonic Distortion vs V_{OCM} at 1 MHz	Figure 11
Two-Tone, Second- and Third-Order Intermodulation Distortion vs Frequency	Figure 12
Single-Ended Output Voltage Swing vs Load Resistance	Figure 13
Main Amplifier Differential Output Impedance vs Frequency	Figure 14
Frequency Response vs C_{LOAD} ($R_{LOAD} = 1\text{ k}\Omega$)	Figure 15
R_O vs C_{LOAD} ($R_{LOAD} = 1\text{ k}\Omega$)	Figure 16
Rejection Ratio vs Frequency	Figure 17
THS4522, THS4524 Crosstalk (Measured Differentially)	Figure 18
Turn-on Time	Figure 19
Turn-off Time	Figure 20
Input-Referred Voltage Noise and Current Noise Spectral Density	Figure 21
Main Amplifier Differential Open-Loop Gain and Phase	Figure 22
Output Balance Error vs Frequency	Figure 23
V_{OCM} Small-Signal Frequency Response	Figure 24
V_{OCM} Large-Signal Frequency Response	Figure 25
V_{OCM} Input Impedance vs Frequency	Figure 26

Table of Graphs: $V_{S+} - V_{S-} = 5\text{ V}$

TITLE	FIGURE
Small-Signal Frequency Response	Figure 27
Large-Signal Frequency Response	Figure 28
Large- and Small-Signal Pulse Response	Figure 29
Slew Rate vs V_{OUT} Step	Figure 30
Overdrive Recovery	Figure 31
10-kHz Output Spectrum on AP Analyzer	Figure 32
Harmonic Distortion vs Frequency	Figure 33
Harmonic Distortion vs Output Voltage at 1 MHz	Figure 34
Harmonic Distortion vs Gain at 1 MHz	Figure 35
Harmonic Distortion vs Load at 1 MHz	Figure 36
Harmonic Distortion vs V_{OCM} at 1 MHz	Figure 37
Two-Tone, Second- and Third-Order Intermodulation Distortion vs Frequency	Figure 38
Single-Ended Output Voltage Swing vs Load Resistance	Figure 39
Main Amplifier Differential Output Impedance vs Frequency	Figure 40
Frequency Response vs C_{LOAD} ($R_{LOAD} = 1\text{ k}\Omega$)	Figure 41
R_O vs C_{LOAD} ($R_{LOAD} = 1\text{ k}\Omega$)	Figure 42
Rejection Ratio vs Frequency	Figure 43
THS4522, THS4524 Crosstalk (Measured Differentially)	Figure 44
Turn-on Time	Figure 45
Turn-off Time	Figure 46
Input-Referred Voltage Noise and Current Noise Spectral Density	Figure 47
Main Amplifier Differential Open-Loop Gain and Phase	Figure 48
Output Balance Error vs Frequency	Figure 49
V_{OCM} Small-Signal Frequency Response	Figure 50
V_{OCM} Large-Signal Frequency Response	Figure 51
V_{OCM} Input Impedance vs Frequency	Figure 52

TYPICAL CHARACTERISTICS: $V_{S+} - V_{S-} = 3.3\text{ V}$

At $V_{S+} = +3.3\text{ V}$, $V_{S-} = 0\text{ V}$, $V_{OCM} = \text{open}$, $V_{OUT} = 2\text{ V}_{PP}$ (differential), $R_L = 1\text{ k}\Omega$ differential, $G = 1\text{ V/V}$, single-ended input, differential output, and input and output referenced to midsupply, unless otherwise noted.

SMALL-SIGNAL FREQUENCY RESPONSE

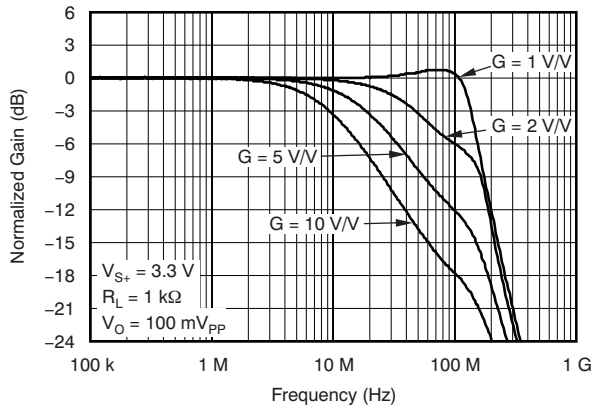

Figure 1.

LARGE-SIGNAL FREQUENCY RESPONSE

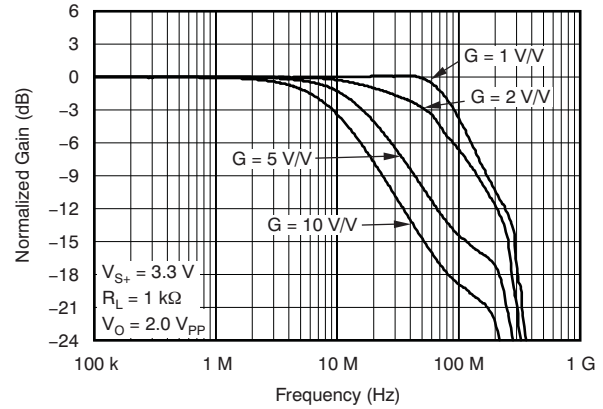

Figure 2.

LARGE- AND SMALL-SIGNAL PULSE RESPONSE

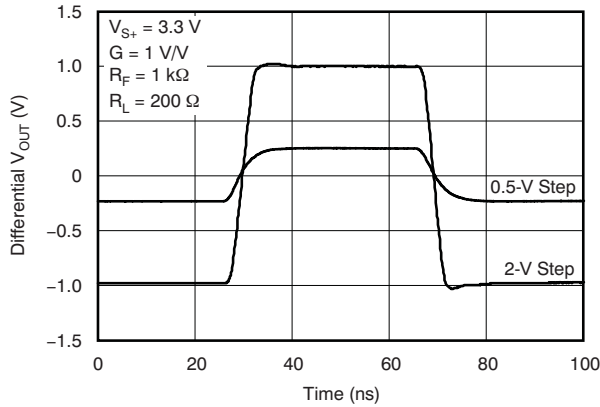

Figure 3.

SLEW RATE vs V_{OUT}

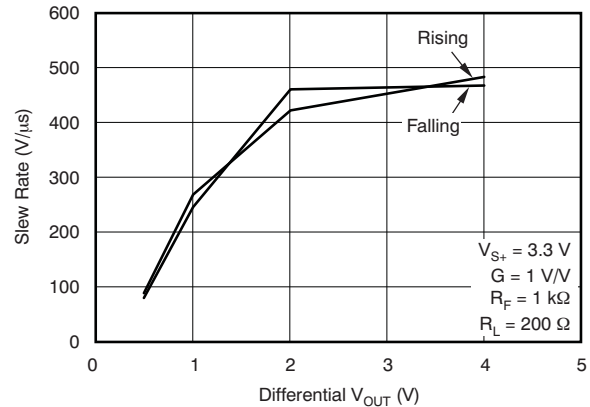

Figure 4.

OVERDRIVE RECOVERY

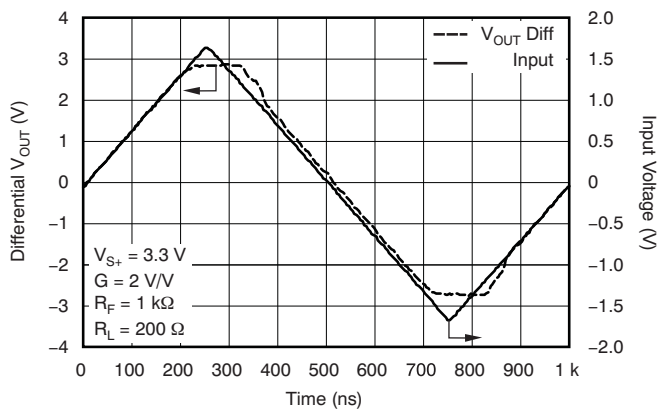

Figure 5.

10-kHz OUTPUT SPECTRUM ON AP ANALYZER

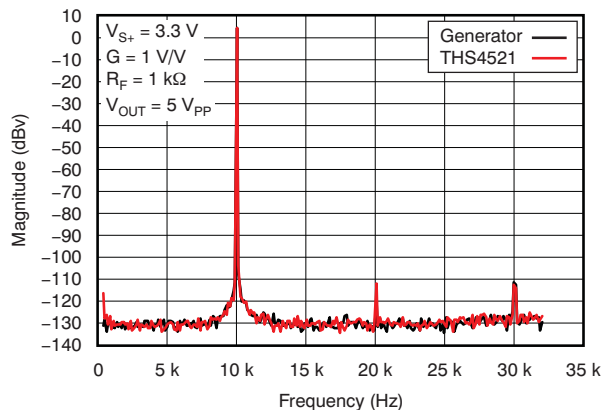

Figure 6.

TYPICAL CHARACTERISTICS: $V_{S+} - V_{S-} = 3.3\text{ V}$ (continued)

At $V_{S+} = +3.3\text{ V}$, $V_{S-} = 0\text{ V}$, $V_{OCM} = \text{open}$, $V_{OUT} = 2\text{ V}_{PP}$ (differential), $R_L = 1\text{ k}\Omega$ differential, $G = 1\text{ V/V}$, single-ended input, differential output, and input and output referenced to midsupply, unless otherwise noted.

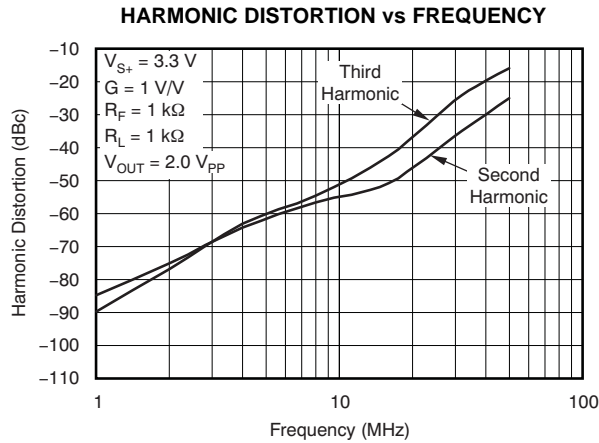

Figure 7.

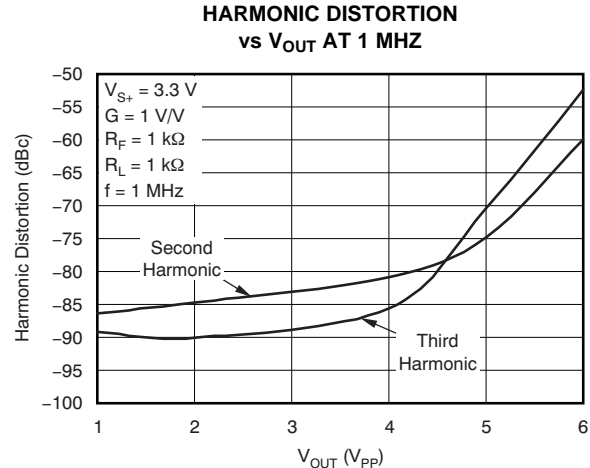

Figure 8.

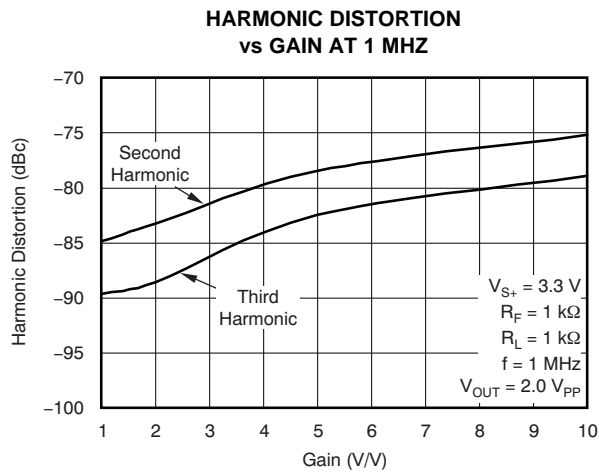

Figure 9.

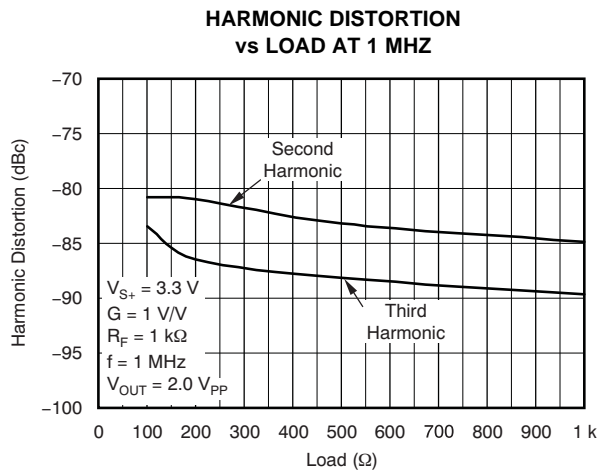

Figure 10.

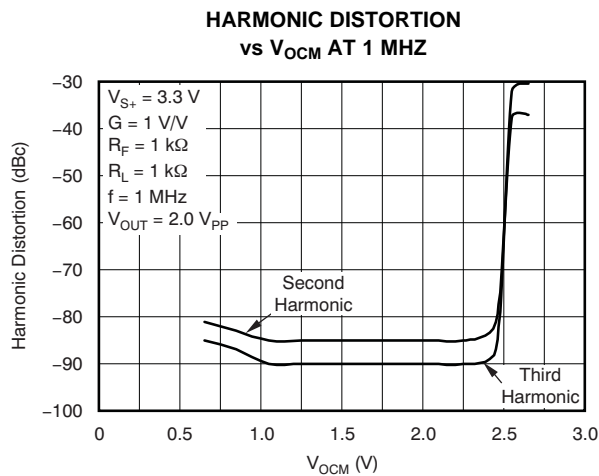

Figure 11.

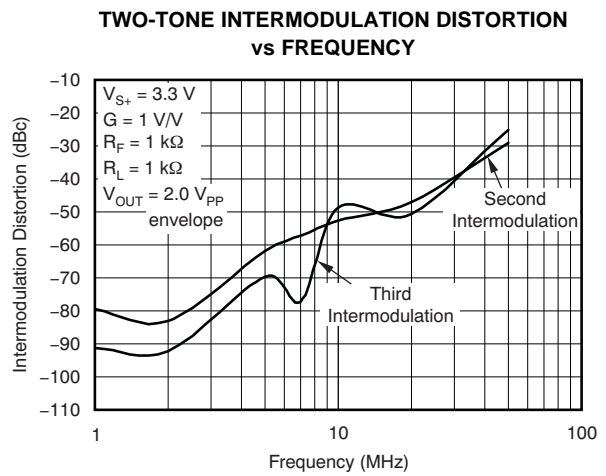

Figure 12.

TYPICAL CHARACTERISTICS: $V_{S+} - V_{S-} = 3.3\text{ V}$ (continued)

At $V_{S+} = +3.3\text{ V}$, $V_{S-} = 0\text{ V}$, $V_{OCM} = \text{open}$, $V_{OUT} = 2\text{ V}_{PP}$ (differential), $R_L = 1\text{ k}\Omega$ differential, $G = 1\text{ V/V}$, single-ended input, differential output, and input and output referenced to midsupply, unless otherwise noted.

SINGLE-ENDED OUTPUT VOLTAGE SWING vs LOAD RESISTANCE

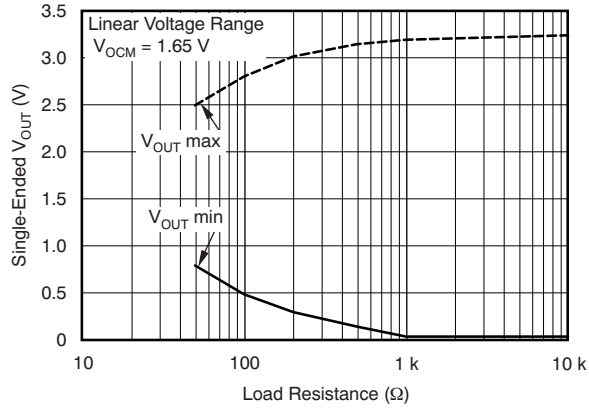

Figure 13.

MAIN AMPLIFIER DIFFERENTIAL OUTPUT IMPEDANCE vs FREQUENCY

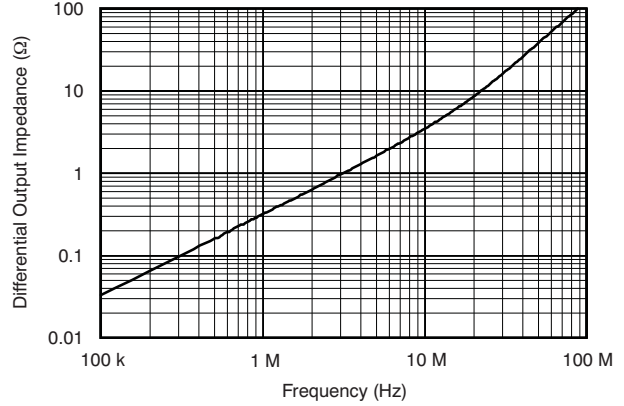

Figure 14.

**FREQUENCY RESPONSE vs C_{LOAD}
 $R_{LOAD} = 1\text{ k}\Omega$**

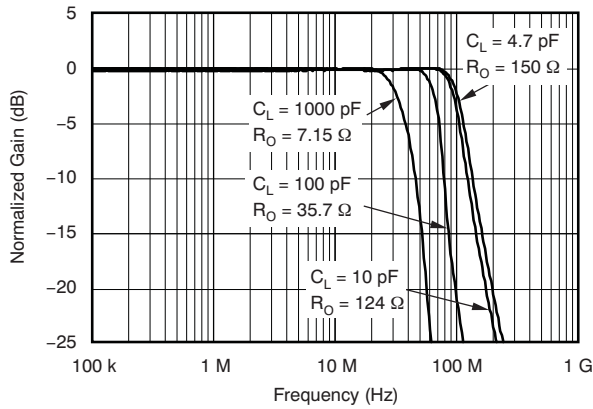

Figure 15.

**R_O vs C_{LOAD}
 $R_{LOAD} = 1\text{ k}\Omega$**

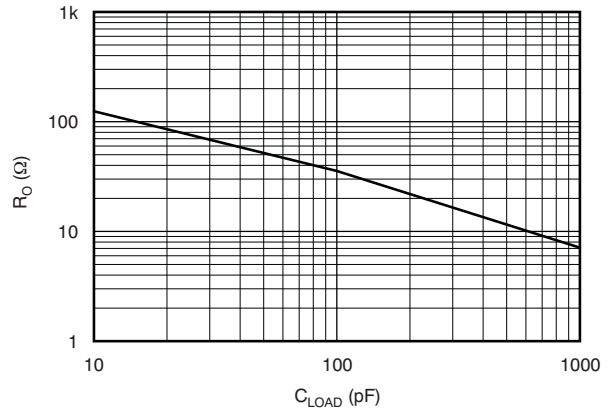

Figure 16.

REJECTION RATIO vs FREQUENCY

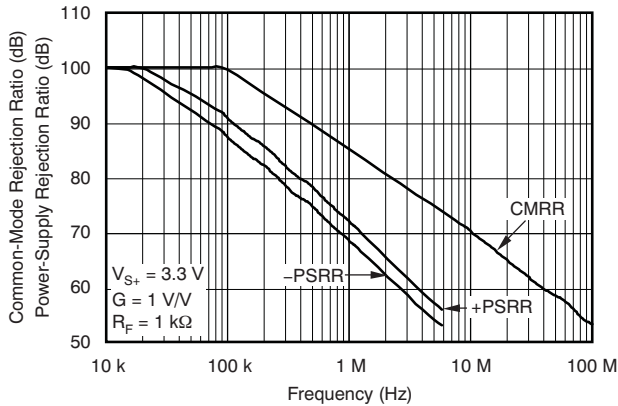

Figure 17.

**THS4522, THS4524
CROSSTALK (MEASURED DIFFERENTIALLY)**

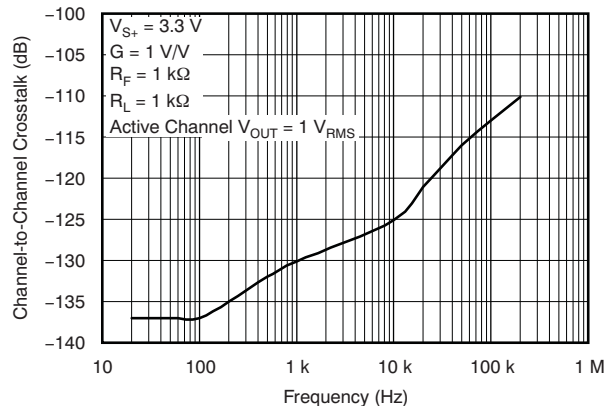

Figure 18.

TYPICAL CHARACTERISTICS: $V_{S+} - V_{S-} = 3.3\text{ V}$ (continued)

At $V_{S+} = +3.3\text{ V}$, $V_{S-} = 0\text{ V}$, $V_{OCM} = \text{open}$, $V_{OUT} = 2\text{ V}_{PP}$ (differential), $R_L = 1\text{ k}\Omega$ differential, $G = 1\text{ V/V}$, single-ended input, differential output, and input and output referenced to midsupply, unless otherwise noted.

TURN-ON TIME

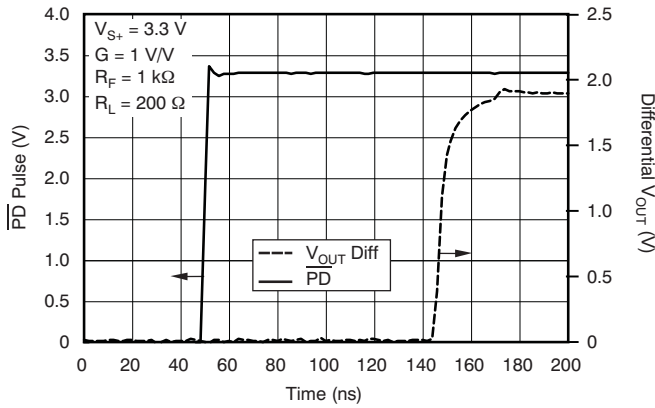

Figure 19.

TURN-OFF TIME

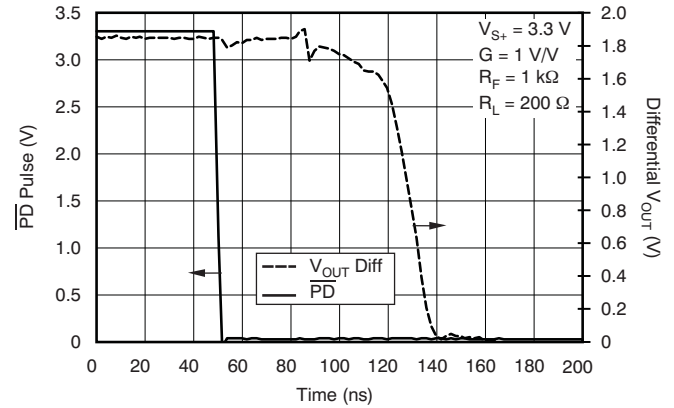

Figure 20.

INPUT-REFERRED VOLTAGE AND CURRENT NOISE SPECTRAL DENSITY

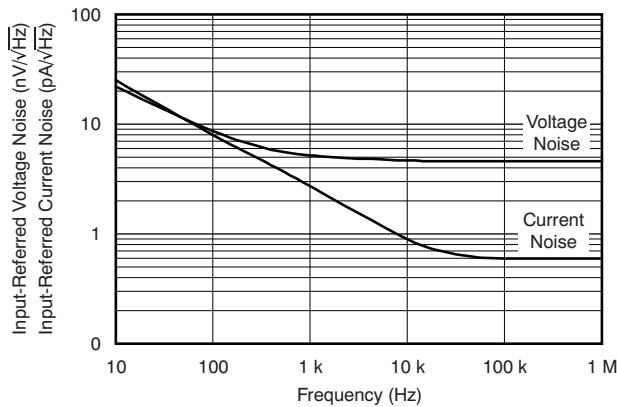

Figure 21.

MAIN AMPLIFIER DIFFERENTIAL OPEN-LOOP GAIN AND PHASE

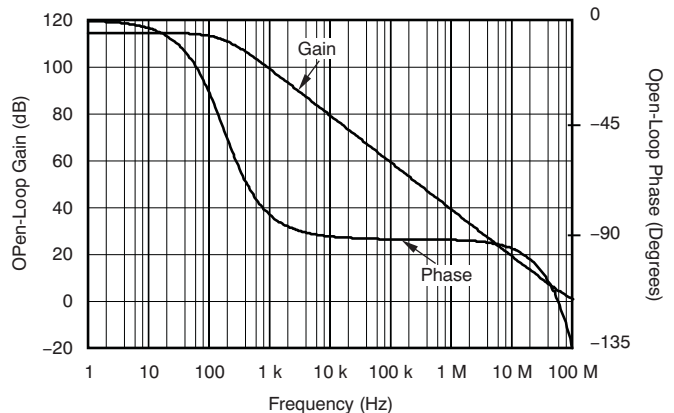

Figure 22.

OUTPUT BALANCE ERROR vs FREQUENCY

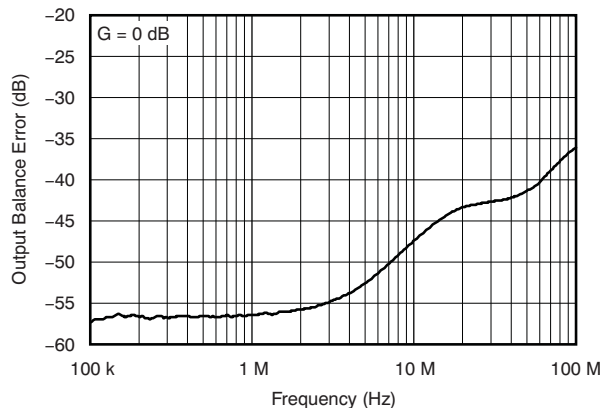

Figure 23.

V_{OCM} SMALL-SIGNAL FREQUENCY RESPONSE

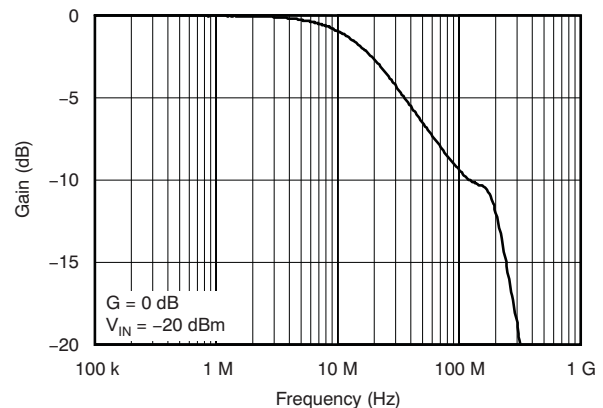
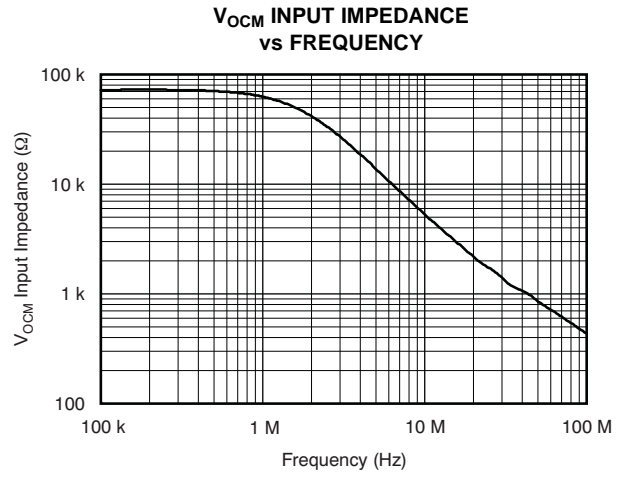
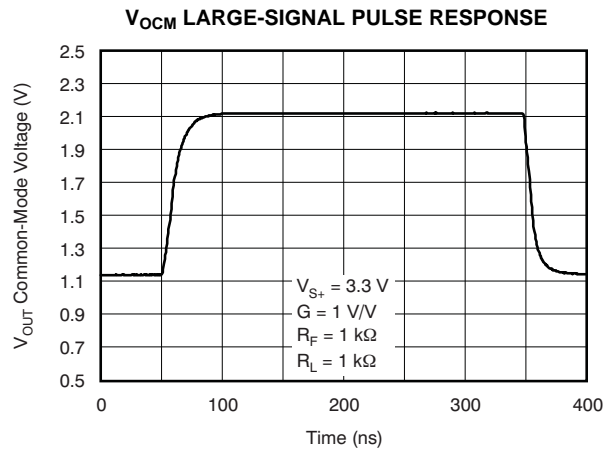

Figure 24.

TYPICAL CHARACTERISTICS: $V_{S+} - V_{S-} = 3.3\text{ V}$ (continued)

At $V_{S+} = +3.3\text{ V}$, $V_{S-} = 0\text{ V}$, $V_{OCM} = \text{open}$, $V_{OUT} = 2\text{ V}_{PP}$ (differential), $R_L = 1\text{ k}\Omega$ differential, $G = 1\text{ V/V}$, single-ended input, differential output, and input and output referenced to midsupply, unless otherwise noted.



TYPICAL CHARACTERISTICS: 5 V

At $V_{S+} = +5\text{ V}$, $V_{S-} = 0\text{ V}$, $V_{OCM} = \text{open}$, $V_{OUT} = 2\text{ V}_{PP}$ (differential), $R_F = 1\text{ k}\Omega$, $R_L = 1\text{ k}\Omega$ differential, $G = 1\text{ V/V}$, single-ended input, differential output, and input and output referenced to midsupply, unless otherwise noted.

SMALL-SIGNAL FREQUENCY RESPONSE

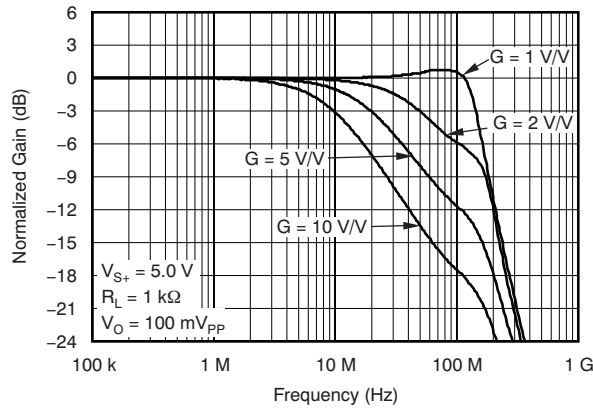

Figure 27.

LARGE-SIGNAL FREQUENCY RESPONSE

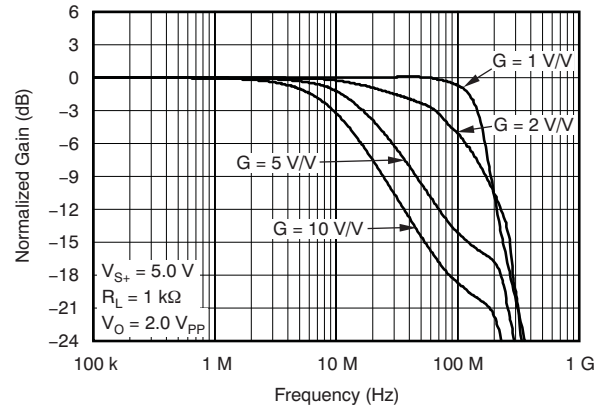

Figure 28.

LARGE- AND SMALL-SIGNAL PULSE RESPONSE

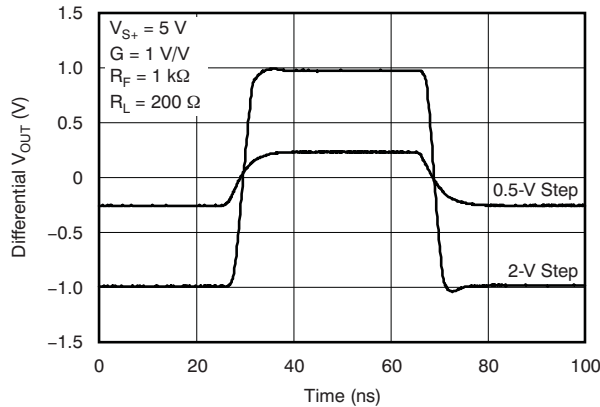

Figure 29.

SLEW RATE vs V_OUT

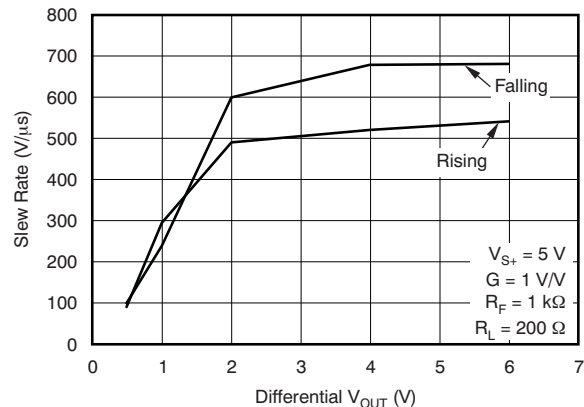

Figure 30.

OVERDRIVE RECOVERY

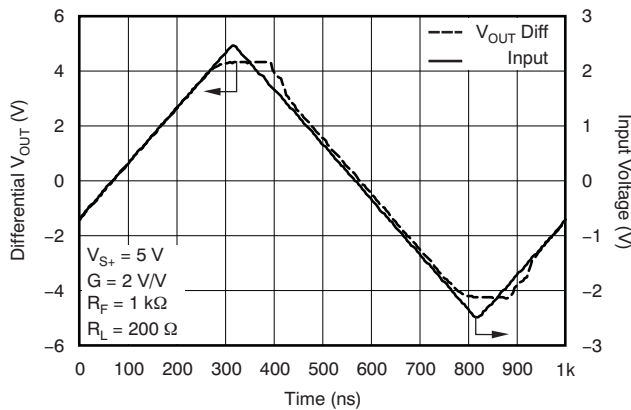

Figure 31.

10-kHz OUTPUT SPECTRUM ON AP ANALYZER AT V_OUT = 8 V_PP

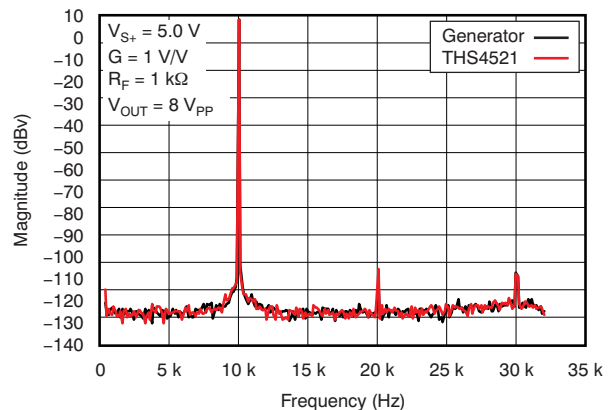

Figure 32.

TYPICAL CHARACTERISTICS: 5 V (continued)

At $V_{S+} = +5\text{ V}$, $V_{S-} = 0\text{ V}$, $V_{OCM} = \text{open}$, $V_{OUT} = 2\text{ V}_{PP}$ (differential), $R_F = 1\text{ k}\Omega$, $R_L = 1\text{ k}\Omega$ differential, $G = 1\text{ V/V}$, single-ended input, differential output, and input and output referenced to midsupply, unless otherwise noted.

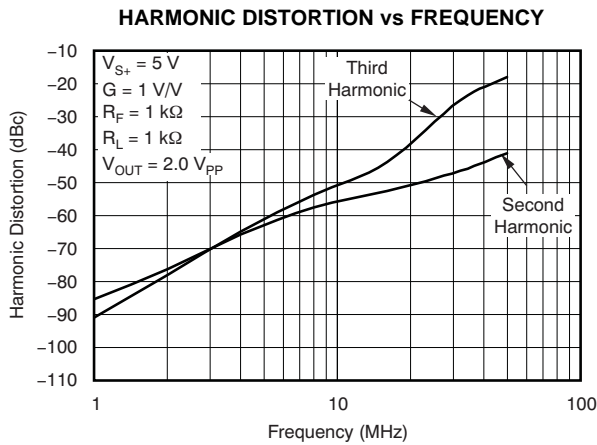

Figure 33.

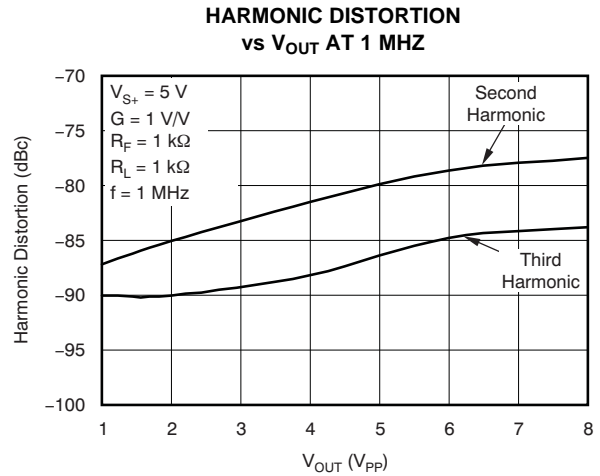

Figure 34.

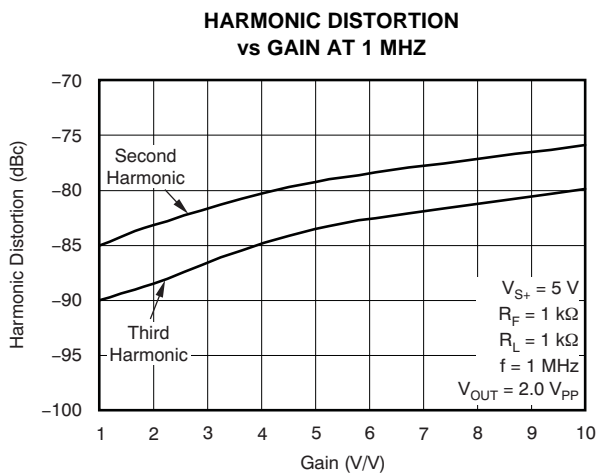

Figure 35.

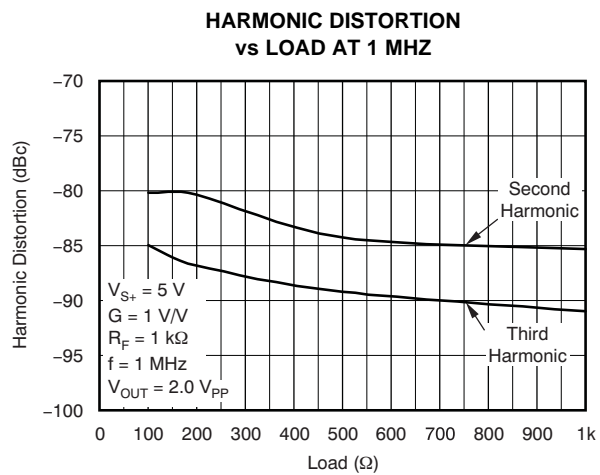

Figure 36.

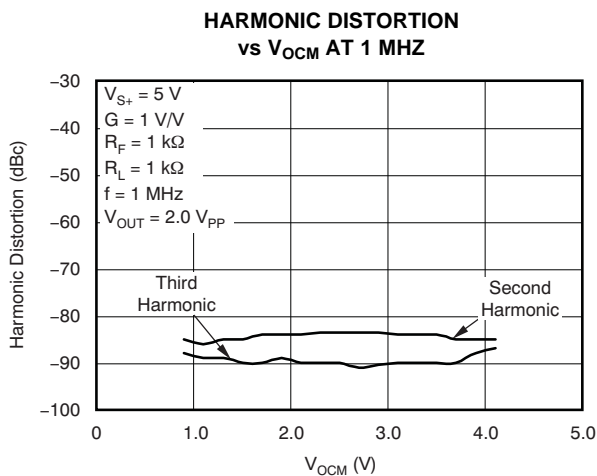

Figure 37.

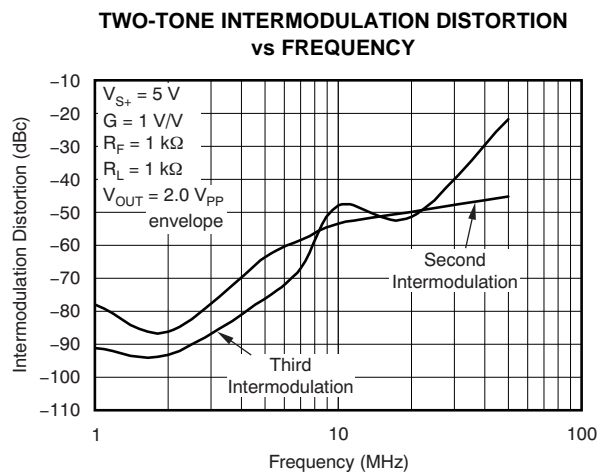

Figure 38.

TYPICAL CHARACTERISTICS: 5 V (continued)

At $V_{S+} = +5\text{ V}$, $V_{S-} = 0\text{ V}$, $V_{OCM} = \text{open}$, $V_{OUT} = 2\text{ V}_{PP}$ (differential), $R_F = 1\text{ k}\Omega$, $R_L = 1\text{ k}\Omega$ differential, $G = 1\text{ V/V}$, single-ended input, differential output, and input and output referenced to midsupply, unless otherwise noted.

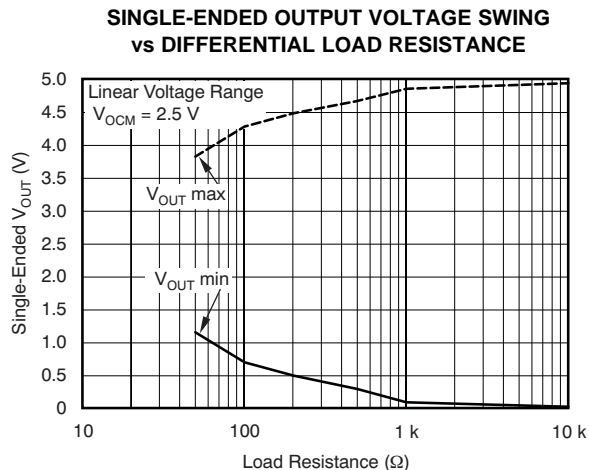

Figure 39.

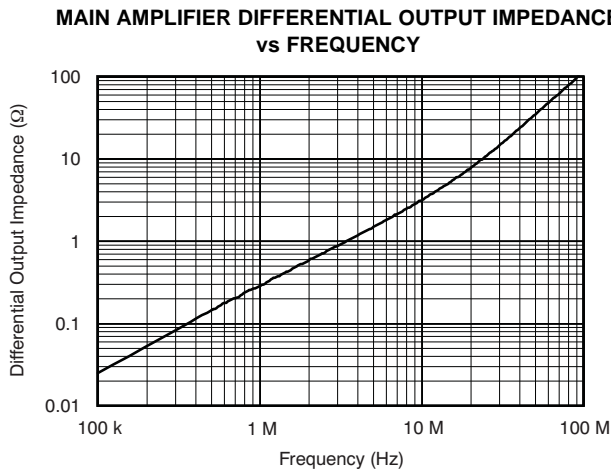

Figure 40.

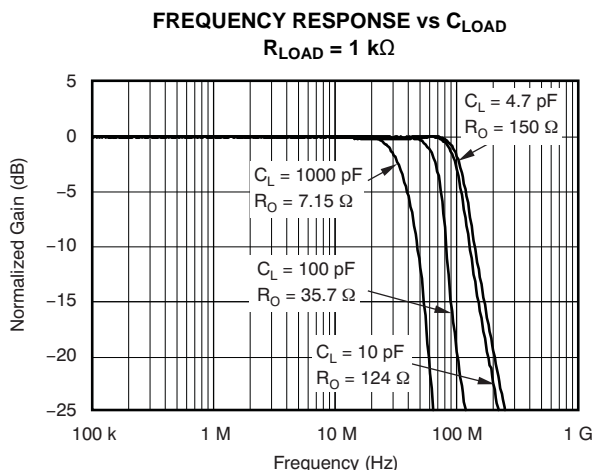

Figure 41.

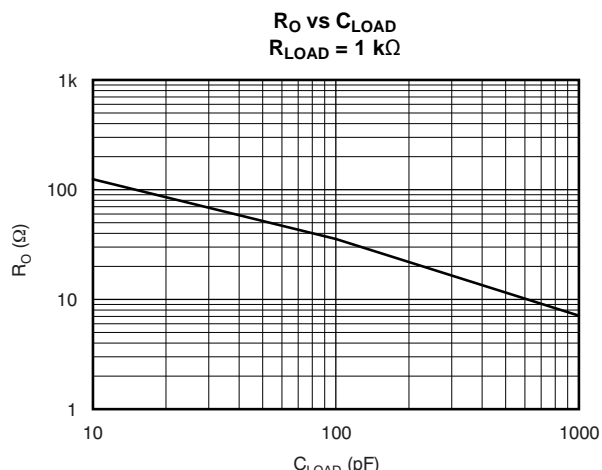

Figure 42.

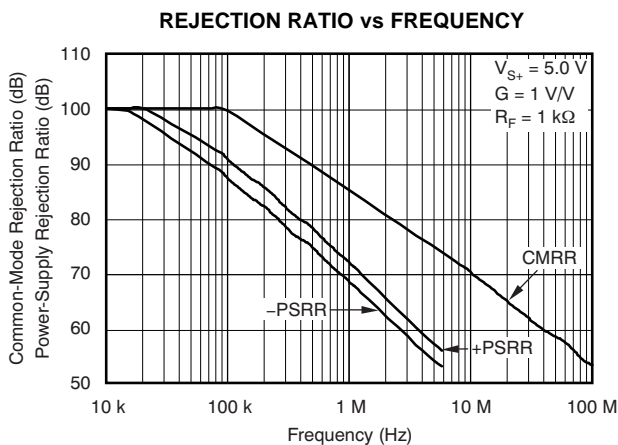

Figure 43.

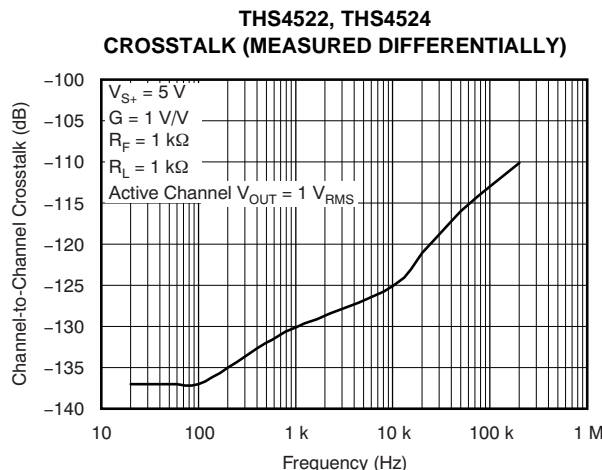

Figure 44.

TYPICAL CHARACTERISTICS: 5 V (continued)

At $V_{S+} = +5\text{ V}$, $V_{S-} = 0\text{ V}$, $V_{OCM} = \text{open}$, $V_{OUT} = 2\text{ V}_{PP}$ (differential), $R_F = 1\text{ k}\Omega$, $R_L = 1\text{ k}\Omega$ differential, $G = 1\text{ V/V}$, single-ended input, differential output, and input and output referenced to midsupply, unless otherwise noted.

TURN-ON TIME

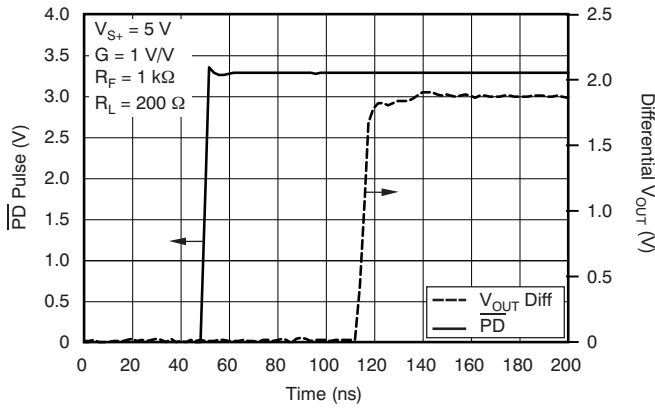

Figure 45.

TURN-OFF TIME

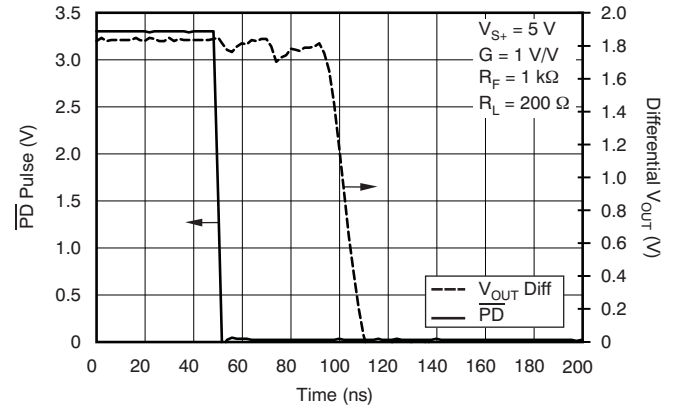

Figure 46.

INPUT-REFERRED VOLTAGE AND CURRENT NOISE SPECTRAL DENSITY

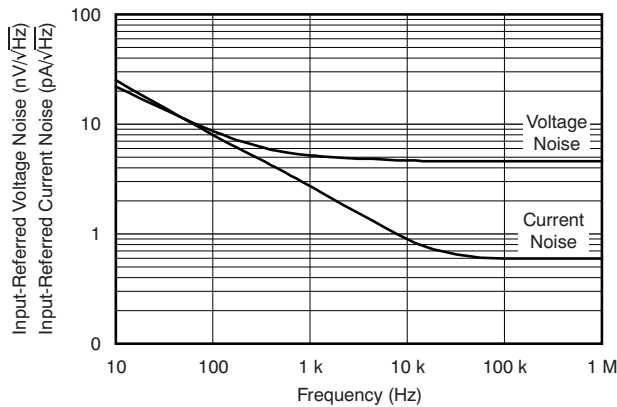

Figure 47.

MAIN AMPLIFIER DIFFERENTIAL OPEN-LOOP GAIN AND PHASE

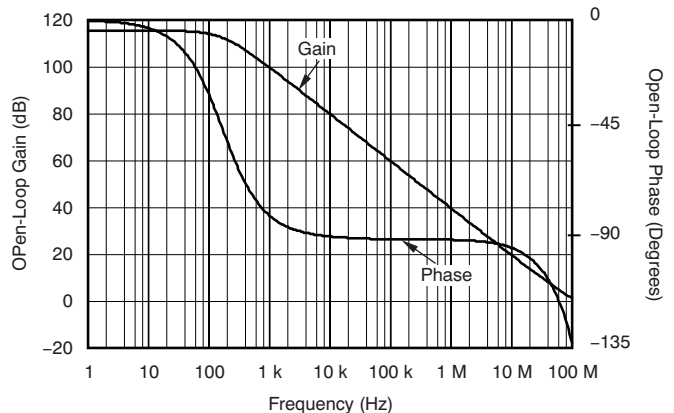

Figure 48.

OUTPUT BALANCE ERROR vs FREQUENCY

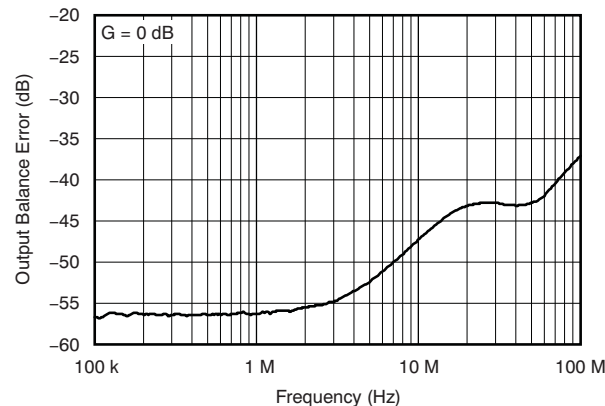

Figure 49.

V_{OCM} SMALL-SIGNAL FREQUENCY RESPONSE

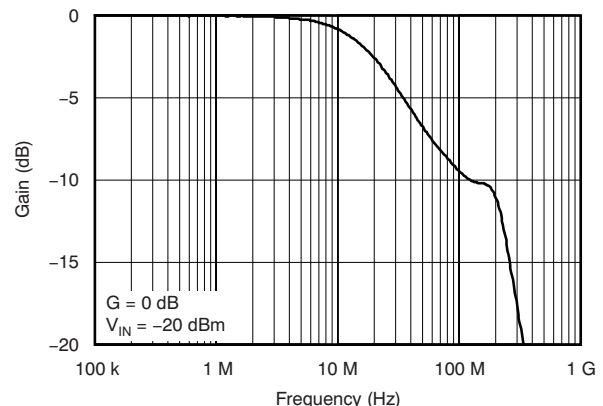

Figure 50.

TYPICAL CHARACTERISTICS: 5 V (continued)

At $V_{S+} = +5\text{ V}$, $V_{S-} = 0\text{ V}$, $V_{OCM} = \text{open}$, $V_{OUT} = 2\text{ V}_{PP}$ (differential), $R_F = 1\text{ k}\Omega$, $R_L = 1\text{ k}\Omega$ differential, $G = 1\text{ V/V}$, single-ended input, differential output, and input and output referenced to midsupply, unless otherwise noted.

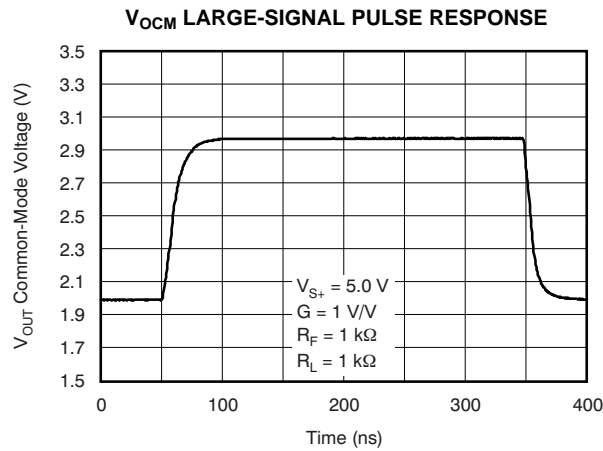

Figure 51.

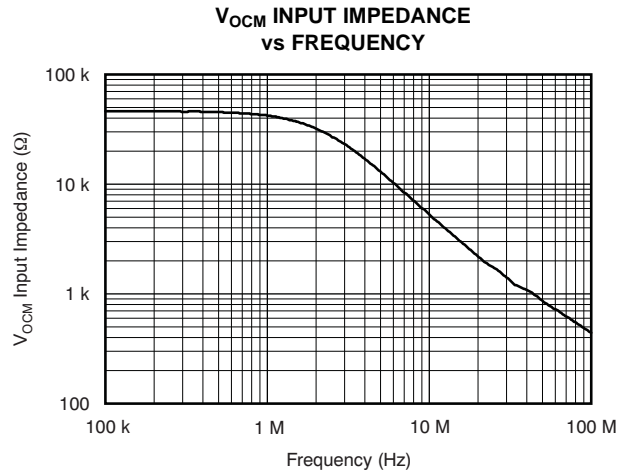

Figure 52.

TEST CIRCUITS

Overview

The THS4521, THS4522, and THS4524 family is tested with the test circuits shown in this section; all circuits are built using the available THS4521 evaluation module (EVM). For simplicity, power-supply decoupling is not shown; see the layout in the [Applications](#) section for recommendations. Depending on the test conditions, component values change in accordance with [Table 1](#) and [Table 2](#), or as otherwise noted. In some cases the signal generators used are ac-coupled and in others they dc-coupled 50-Ω sources. To balance the amplifier when ac-coupled, a 0.22-μF capacitor and 49.9-Ω resistor to ground are inserted across R_{IT} on the alternate input; when dc-coupled, only the 49.9-Ω resistor to ground is added across R_{IT} . A split power supply is used to ease the interface to common test equipment, but the amplifier can be operated in a single-supply configuration as described in the [Applications](#) section with no impact on performance. Also, for most of the tests, except as noted, the devices are tested with single-ended inputs and a transformer on the output to convert the differential output to single-ended because common lab test equipment has single-ended inputs and outputs. Similar or better performance can be expected with differential inputs and outputs.

As a result of the voltage divider on the output formed by the load component values, the amplifier output is attenuated. The **Atten** column in [Table 2](#) shows the attenuation expected from the resistor divider. When using a transformer at the output (as shown in [Figure 54](#)), the signal sees slightly more loss because of transformer and line loss; these numbers are approximate.

Table 1. Gain Component Values for Single-Ended Input⁽¹⁾

Gain	R_F	R_G	R_{IT}
1 V/V	1 kΩ	1 kΩ	52.3 Ω
2 V/V	1 kΩ	487 Ω	53.6 Ω
5 V/V	1 kΩ	187 Ω	59.0 Ω
10 V/V	1 kΩ	86.6 Ω	69.8 Ω

- Gain setting includes 50-Ω source impedance. Components are chosen to achieve gain and 50-Ω input termination.

Table 2. Load Component Values For 1:1 Differential to Single-Ended Output Transformer⁽¹⁾

R_L	R_O	R_{OT}	Atten
100 Ω	24.9 Ω	Open	6 dB
200 Ω	86.6 Ω	69.8 Ω	16.8 dB
499 Ω	237 Ω	56.2 Ω	25.5 dB
1 kΩ	487 Ω	52.3 Ω	31.8 dB

- Total load includes 50-Ω termination by the test equipment. Components are chosen to achieve load and 50-Ω line termination through a 1:1 transformer.

Frequency Response

The circuit shown in [Figure 53](#) is used to measure the frequency response of the circuit.

An HP network analyzer is used as the signal source and the measurement device. The output impedance of the HP network analyzer is dc-coupled and is 50 Ω. R_{IT} and R_G are chosen to impedance-match to 50 Ω and maintain the proper gain. To balance the amplifier, a 49.9-Ω resistor to ground is inserted across R_{IT} on the alternate input.

The output is probed using a Tektronix high-impedance differential probe across the 953-Ω resistor and referred to the amplifier output by adding back the 0.42-dB because of the voltage divider on the output.

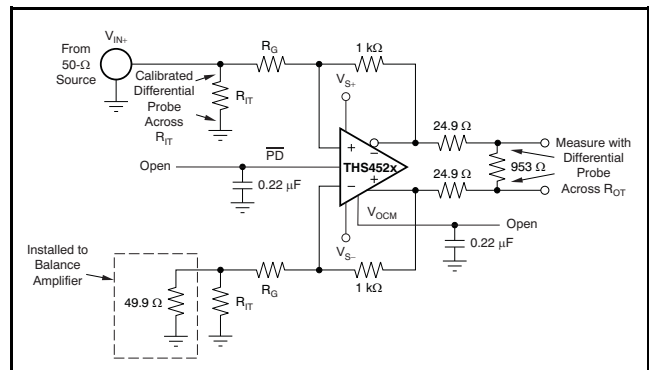

Figure 53. Frequency Response Test Circuit

Distortion

The circuit shown in [Figure 54](#) is used to measure harmonic and intermodulation distortion of the amplifier.

An HP signal generator is used as the signal source and the output is measured with a Rhode and Schwarz spectrum analyzer. The output impedance of the HP signal generator is ac-coupled and is 50 Ω. R_{IT} and R_G are chosen to impedance match to 50 Ω and maintain the proper gain. To balance the amplifier, a 0.22-μF capacitor and 49.9-Ω resistor to ground are inserted across R_{IT} on the alternate input.

A low-pass filter is inserted in series with the input to reduce harmonics generated at the signal source. The level of the fundamental is measured and then a high-pass filter is inserted at the output to reduce the fundamental so it does not generate distortion in the input of the spectrum analyzer.

The transformer used in the output to convert the signal from differential to single-ended is an ADT1-1WT. It limits the frequency response of the circuit so that measurements cannot be made below approximately 1 MHz.

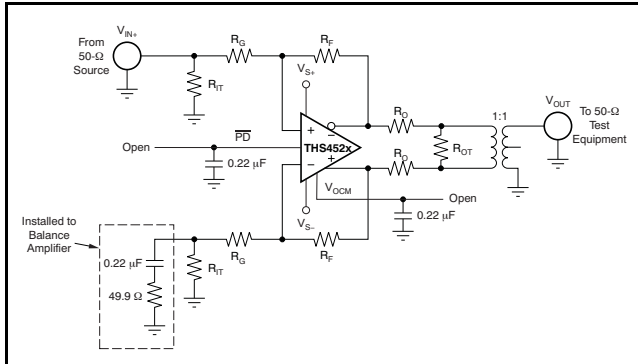

Figure 54. Distortion Test Circuit

Slew Rate, Transient Response, Settling Time, Output Impedance, Overdrive, Output Voltage, and Turn-On/Turn-Off Time

The circuit shown in [Figure 55](#) is used to measure slew rate, transient response, settling time, output impedance, overdrive recovery, output voltage swing, and amplifier turn-on/turn-off time. Turn-on and turn-off time are measured with the same circuit modified for 50-Ω input impedance on the PD input by replacing the 0.22-μF capacitor with a 49.9-Ω resistor. For output impedance, the signal is injected at V_{OUT} with V_{IN} open; the drop across the 2x 49.9-Ω resistors is then used to calculate the impedance seen looking into the amplifier output.

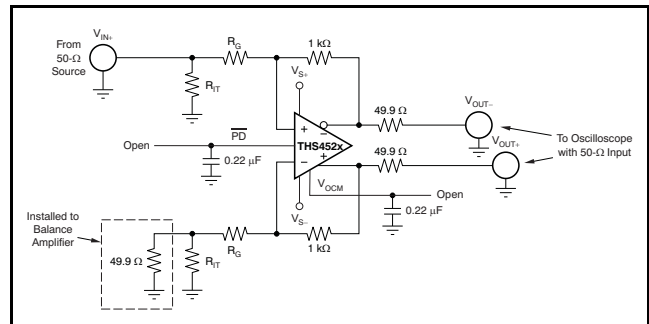

Figure 55. Slew Rate, Transient Response, Settling Time, Output Impedance, Overdrive Recovery, V_{OUT} Swing, and Turn-On/Turn-Off Test Circuit

Common-Mode and Power-Supply Rejection

The circuit shown in Figure 56 is used to measure the CMRR. The signal from the network analyzer is applied common-mode to the input. Figure 57 is used to measure the PSRR of V_{S+} and V_{S-} . The power supply under test is applied to the network analyzer dc offset input. For both CMRR and PSRR, the output is probed using a Tektronix high-impedance differential probe across the 953- Ω resistor and referred to the amplifier output by adding back the 0.42-dB as a result of the voltage divider on the output. For these tests, the resistors are matched for best results.

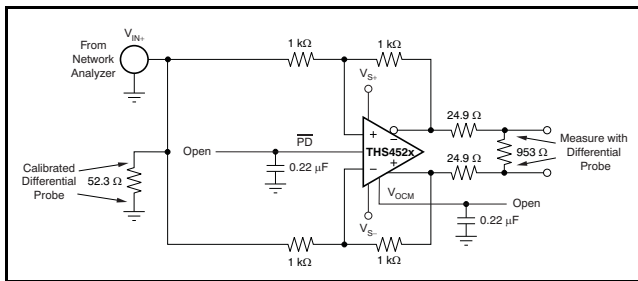

Figure 56. CMRR Test Circuit

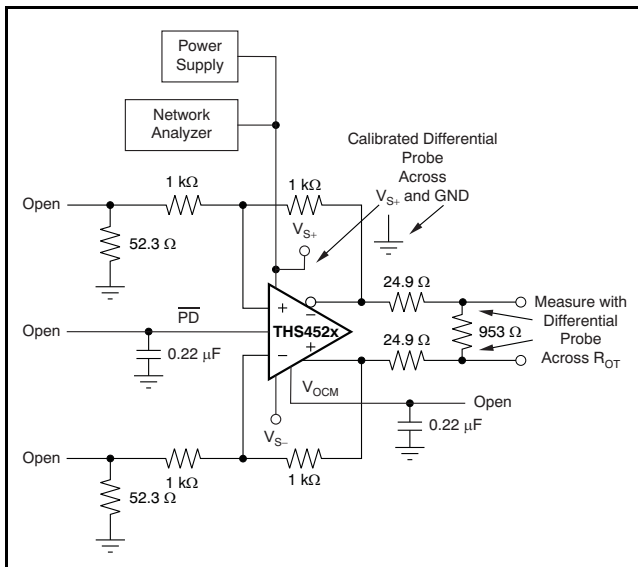

Figure 57. PSRR Test Circuit

V_{OCM} Input

The circuit illustrated in Figure 58 is used to measure the frequency response and input impedance of the V_{OCM} input. Frequency response is measured using a Tektronix high-impedance differential probe, with $R_{CM} = 0 \Omega$ at the common point of V_{OUT+} and V_{OUT-} , formed at the summing junction of the two matched 499- Ω resistors, with respect to ground. The input impedance is measured using a Tektronix high-impedance differential probe at the V_{OCM} input with $R_{CM} = 10 \text{ k}\Omega$ and the drop across the 10-k Ω resistor is used to calculate the impedance seen looking into the amplifier V_{OCM} input.

The circuit shown in Figure 59 measures the transient response and slew rate of the V_{OCM} input. A 1-V step input is applied to the V_{OCM} input and the output is measured using a 50- Ω oscilloscope input referenced back to the amplifier output.

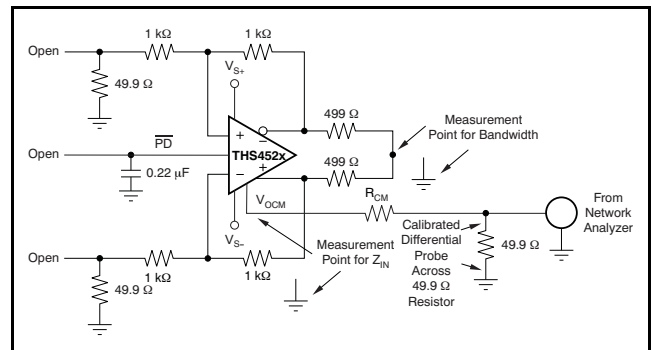

Figure 58. V_{OCM} Input Test Circuit

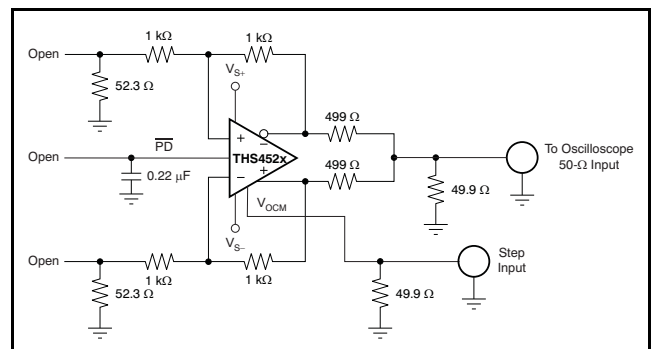

Figure 59. V_{OCM} Transient Response and Slew Rate Test Circuit

APPLICATION INFORMATION

The following circuits show application information for the THS4521, THS4522, and THS4524 family. For simplicity, power-supply decoupling capacitors are not shown in these diagrams; see the [EVM and Layout Recommendations](#) section for suggested guidelines. For more details on the use and operation of fully differential op amps, refer to the Application Report [Fully-Differential Amplifiers \(SLOA054\)](#), available for download from the TI web site at [www.ti.com](#).

Differential Input to Differential Output Amplifier

The THS4521, THS4522, and THS4524 family are fully-differential operational amplifiers that can be used to amplify differential input signals to differential output signals. [Figure 60](#) shows a basic block diagram of the circuit (V_{OCM} and \overline{PD} inputs not shown). The gain of the circuit is set by R_F divided by R_G .

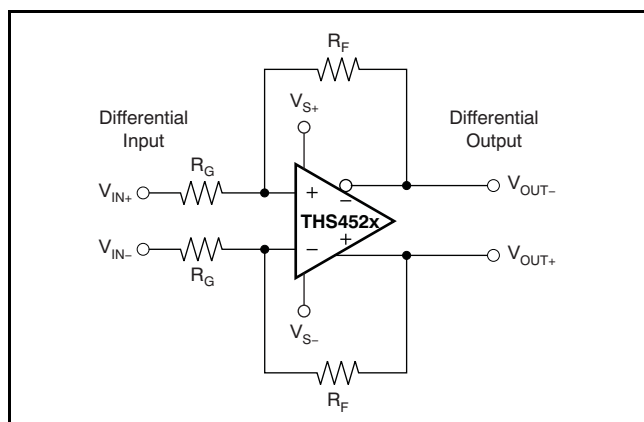

Figure 60. Differential Input to Differential Output Amplifier

Single-Ended Input to Differential Output Amplifier

The THS4521, THS4522, and THS4524 family can also amplify and convert single-ended input signals to differential output signals. [Figure 61](#) illustrates a basic block diagram of the circuit (V_{OCM} and \overline{PD} inputs not shown). The gain of the circuit is again set by R_F divided by R_G .

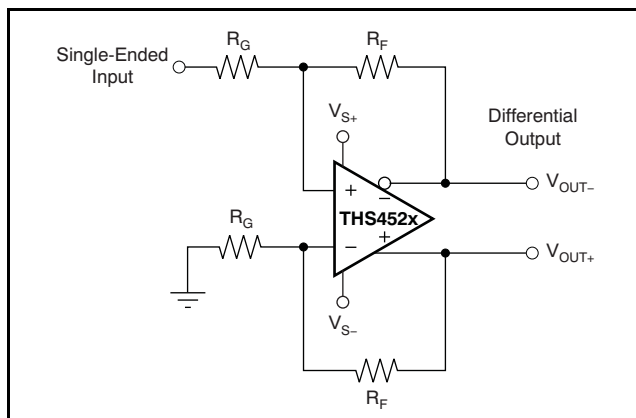

Figure 61. Single-Ended Input to Differential Output Amplifier

Input Common-Mode Voltage Range

The input common-mode voltage of a fully-differential op amp is the voltage at the + and – input pins of the device.

It is important to not violate the input common-mode voltage range (V_{ICR}) of the op amp. Assuming the op amp is in linear operation, the voltage across the input pins is only a few millivolts at most. Therefore, finding the voltage at one input pin determines the input common-mode voltage of the op amp.

Treating the negative input as a summing node, the voltage is given by [Equation 1](#):

$$\left(V_{OUT+} \times \frac{R_G}{R_G + R_F} \right) + \left(V_{IN-} \times \frac{R_F}{R_G + R_F} \right) \quad (1)$$

To determine the V_{ICR} of the op amp, the voltage at the negative input is evaluated at the extremes of V_{OUT+} . As the gain of the op amp increases, the input common-mode voltage becomes closer and closer to the input common-mode voltage of the source.

Setting the Output Common-Mode Voltage

The output common-mode voltage is set by the voltage at the V_{OCM} pin. The internal common-mode control circuit maintains the output common-mode voltage within 5-mV offset (typ) from the set voltage. If left unconnected, the common-mode set point is set to midsupply by internal circuitry, which may be overdriven from an external source.

Figure 62 represents the V_{OCM} input. The internal V_{OCM} circuit has typically 23 MHz of -3 dB bandwidth, which is required for best performance, but it is intended to be a dc bias input pin. A $0.22\text{-}\mu\text{F}$ bypass capacitor is recommended on this pin to reduce noise. The external current required to overdrive the internal resistor divider is given approximately by the formula in Equation 2:

$$I_{EXT} = \frac{2V_{OCM} - (V_{S+} - V_{S-})}{50\text{ k}\Omega}$$

where:

- V_{OCM} is the voltage applied to the V_{OCM} pin (2)

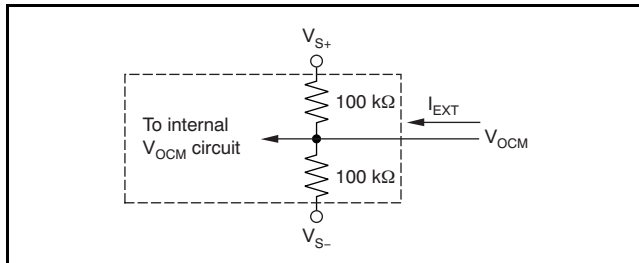

Figure 62. V_{OCM} Input Circuit

Typical Performance Variation with Supply Voltage

The THS4521, THS4522, and THS4524 family of devices provide excellent performance across the specified power-supply range of 2.5 V to 5.5 V with only minor variations. The input and output voltage compliance ranges track with the power supply in nearly a 1:1 correlation. Other changes can be observed in slew rate, output current drive, open-loop gain, bandwidth, and distortion. Table 3 shows the typical variation to be expected in these key performance parameters.

Table 3. Typical Performance Variation versus Power-Supply Voltage

PARAMETER	$V_S = 5\text{ V}$	$V_S = 3.3\text{ V}$	$V_S = 2.5\text{ V}$
-3 -dB Small-signal bandwidth	145 MHz	135 MHz	125 MHz
Slew rate (2-V step)	490 V/ μ s	420 V/ μ s	210 V/ μ s
Harmonic distortion at 1 MHz, $2 V_{PP}$, $R_L = 1\text{ k}\Omega$			
harmonic	-85 dBc	-85 dBc	-84 dBc
harmonic	-91 dBc	-90 dBc	-88 dBc
Open-loop gain	119 dB	116 dB	115 dB
Linear output current drive	55 mA	35 mA	24 mA

Single-Supply Operation

To facilitate testing with common lab equipment, the THS4521EVM allows for split-supply operation; most of the characterization data presented in this data sheet is measured using split-supply power inputs. The device can easily be used with a single-supply power input without degrading performance.

Figure 63 shows a dc-coupled single-supply circuit with single-ended inputs. This circuit can also be applied to differential input sources.

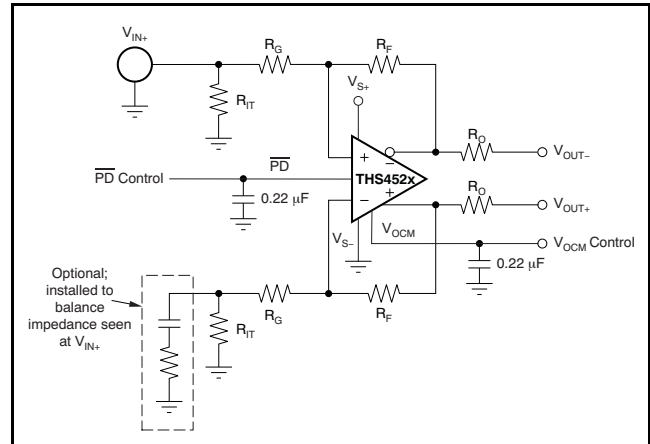

Figure 63. THS4521 DC-Coupled Single-Supply with Single-Ended Inputs

The input common-mode voltage range of the THS4521, THS4522, and THS4524 family is designed to include the negative supply voltage. In the circuit shown in Figure 63, the signal source is referenced to ground. V_{OCM} is set by an external control source or, if left unconnected, the internal circuit defaults to midsupply. Together with the input impedance of the amplifier circuit, R_{IT} provides input termination, which is also referenced to ground.

Note that R_{IT} and optional matching components are added to the alternate input to balance the impedance at signal input.

Low-Power Applications and the Effects of Resistor Values on Bandwidth

For low-power operation, it may be necessary to increase the gain setting resistors values to limit current consumption and not load the source. Using larger value resistors lowers the bandwidth of the THS4521, THS4522, and THS4524 family as a result of the interactions between the resistors, the device parasitic capacitance, and printed circuit board (PCB) parasitic capacitance. Figure 64 shows the small-signal frequency response with 1-k Ω , 10-k Ω , and 100-k Ω resistors for R_F, R_G, and R_L (impedance is assumed to typically increase for all three resistors in low-power applications).

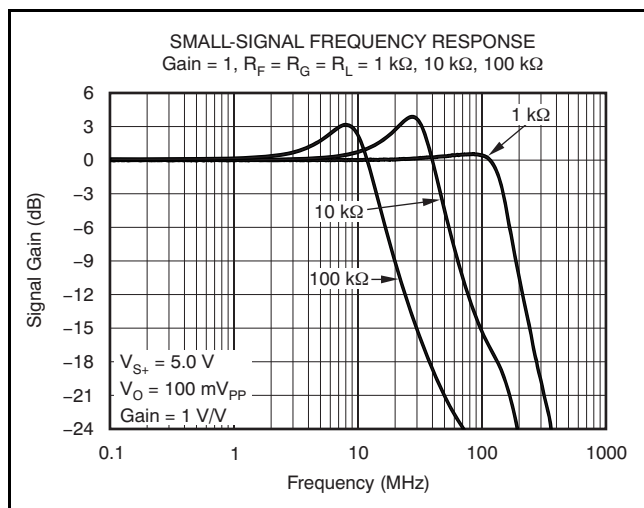

Figure 64. THS4521 Frequency Response with Various Gain Setting and Load Resistor Values

Frequency Response Variation due to Package Options

Users can see variations in the small-signal ($V_{OUT} = 100 \text{ mV}_{PP}$) frequency response between the available package options for the THS4521, THS4522, and THS4524 family as a result of parasitic elements associated with each package and board layout changes. Figure 65 shows the variance measured in the lab; this variance is to be expected even when using a good layout.

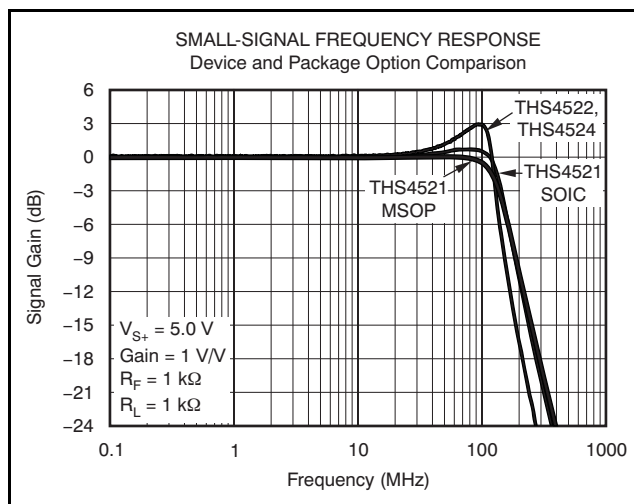

Figure 65. Small-Signal Frequency Response: Package Variations

Driving Capacitive Loads

The THS4521, THS4522, and THS4524 family is designed for a nominal capacitive load of 1 pF on each output to ground. When driving capacitive loads greater than 1 pF, it is recommended to use small resistors (R_O) in series with the output, placed as close to the device as possible. Without R_O , capacitance on the output interacts with the output impedance of the amplifier and causes phase shift in the loop gain of the amplifier that reduces the phase margin. This reduction in phase margin results in frequency response peaking; overshoot, undershoot, and/or ringing when a step or square-wave signal is applied; and may lead to instability or oscillation. Inserting R_O isolates the phase shift from the loop gain path and restores the phase margin, but it also limits bandwidth. Figure 66 shows the recommended values of R_O versus capacitive loads (C_L), and Figure 67 shows an illustration of the frequency response with various values.

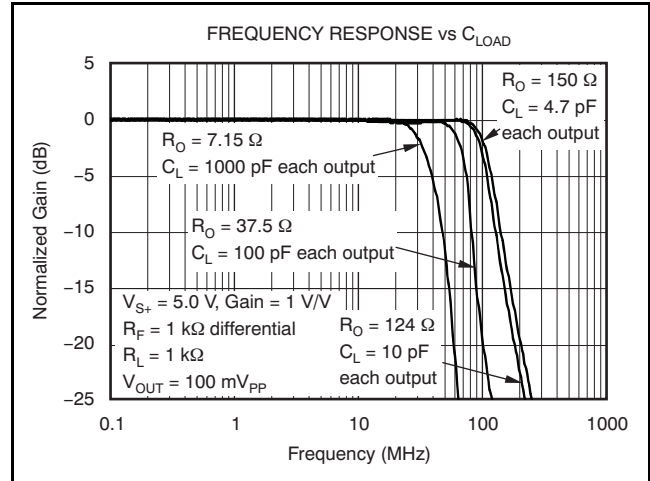

Figure 67. Frequency Response for Various R_O and C_L Values, with $R_{LOAD} = 1\text{ k}\Omega$

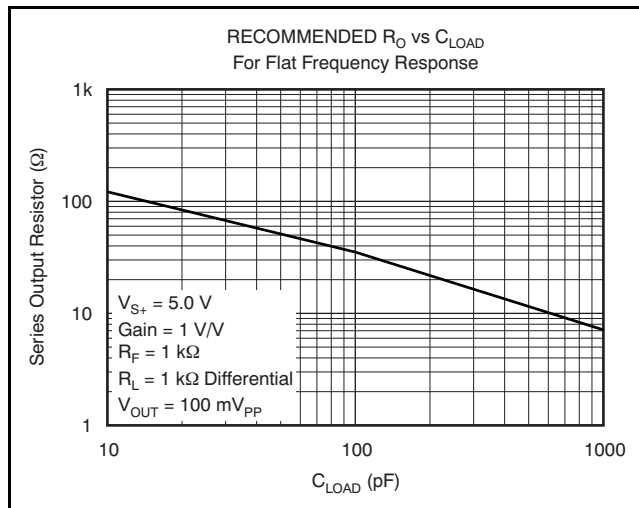

Figure 66. Recommended Series Output Resistor versus Capacitive Load for Flat Frequency Response, with $R_{LOAD} = 1\text{ k}\Omega$

Audio Performance

The THS4521, THS4522, and THS4524 family provide excellent audio performance with very low quiescent power. To show performance in the audio band, the device was tested with a SYS-2722 audio analyzer from Audio Precision. THD+N and FFT tests were performed at $1\text{-}V_{RMS}$ output voltage. Performance is the same on both 3.3-V and 5-V supplies. Figure 68 shows the test circuit used; see Figure 69 and Figure 70 for the performance of the analyzer using internal loopback mode (generator) together with the THS4521.

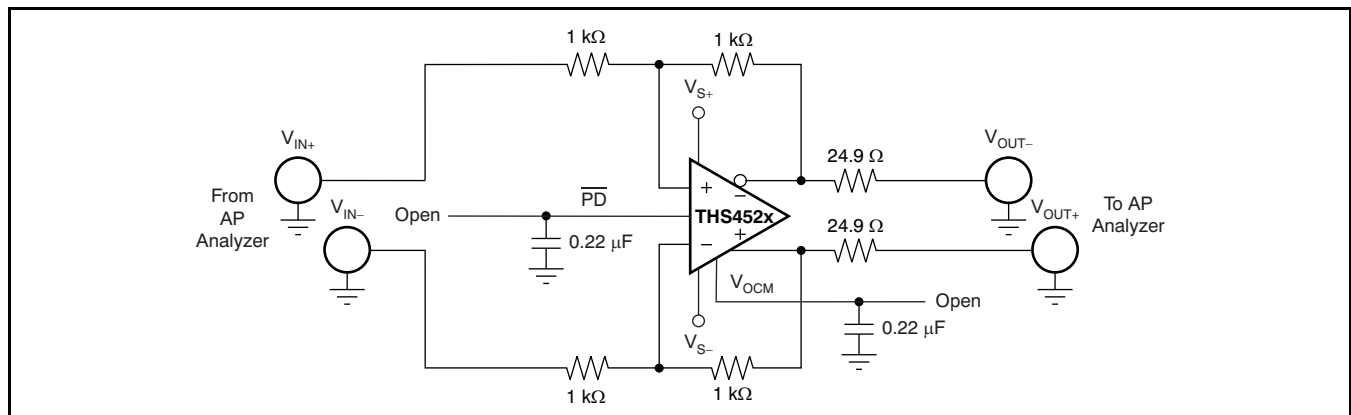

Figure 68. THS4521 AP Analyzer Test Circuit

Note that the harmonic distortion performance is very close to the same with and without the device meaning the THS4521 performance is actually much better than can be directly measured by this method. The actual device performance can be estimated by placing the device in a large noise gain and using the reduction in loop gain correction. The THS4521 is placed in a noise gain of 101 by adding a 10-Ω resistor directly across the input terminals of the circuit shown in Figure 68. This test was performed using the AP instrument as both the signal source and the analyzer. The second-order harmonic distortion at 1 kHz is estimated to be -122 dBc with $V_O = 1V_{RMS}$; third-order harmonic distortion is estimated to be -141 dBc. The third-order harmonic distortion result matches exactly with design simulations, but the second-order harmonic distortion is about 10 dB worse. This result is not unexpected because second-order harmonic distortion performance with a differential signal depends heavily on cancellation as a result of the differential nature of the signal, which depends on board layout, bypass capacitors, external cabling, and so forth. Note that the circuit of Figure 68 is also used to measure crosstalk between channels.

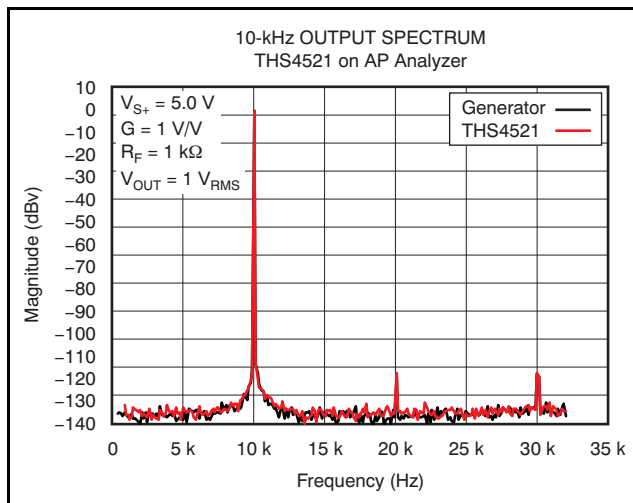

Figure 70. THS4521 1- V_{RMS} 10-kHz FFT Plot

The THS4521 shows even better THD+N performance when driving higher amplitude output, such as 5 V_{PP} that is more typical when driving an ADC. To show performance with an extended frequency range, higher gain, and higher amplitude, the device was tested with 5 V_{PP} up to 80 kHz with the AP. Figure 71 shows the resulting THD+N graph with no weighting.

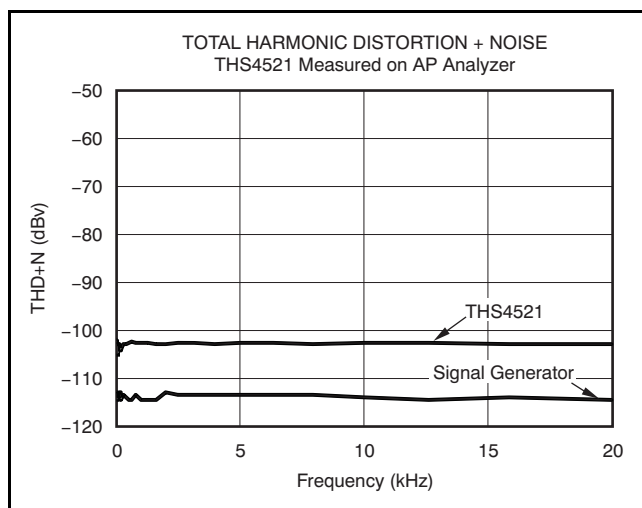

Figure 69. THS4521 1- V_{RMS} 20-Hz to 20-kHz THD+N

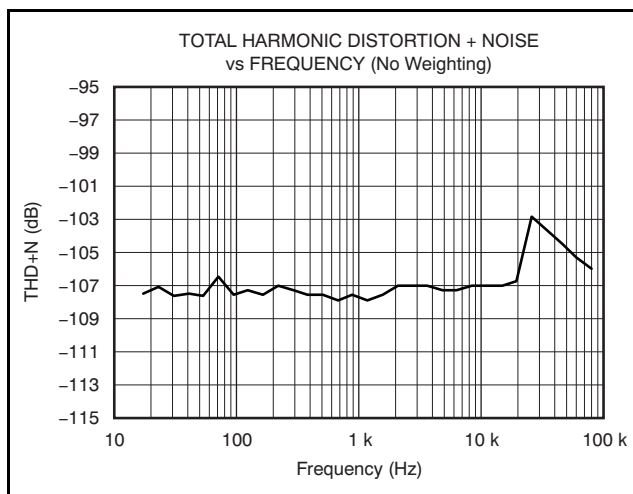

Figure 71. THD+N (No Weighting) on AP, 80-kHz Bandwidth at $G = 1$ with 5- V_{PP} Output

Audio On/Off Pop Performance

The THS4521 was tested to show on and off pop performance by connecting a speaker between the differential outputs and switching the power supply on and off, and also by using the PD function of the THS4521. Testing was done with and without tones. During these tests, no audible pop could be heard.

With no tone input, Figure 72 shows the pop performance when switching power on to the THS4521 and Figure 73 shows the device performance when turning the power off. The transients during power on and off illustrate that no audible pop should be heard.

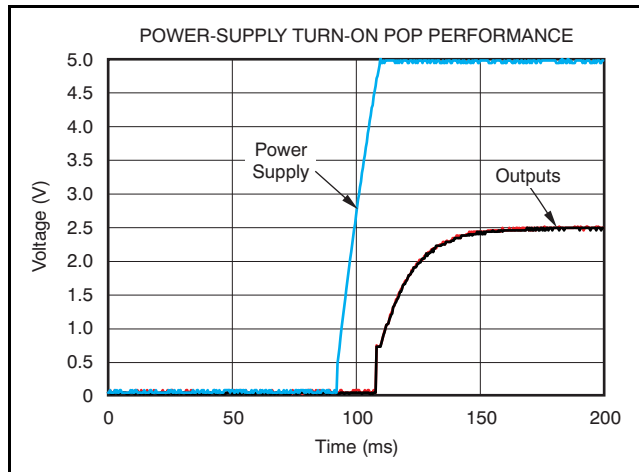

Figure 72. THS4521 Power-Supply Turn-On Pop Performance

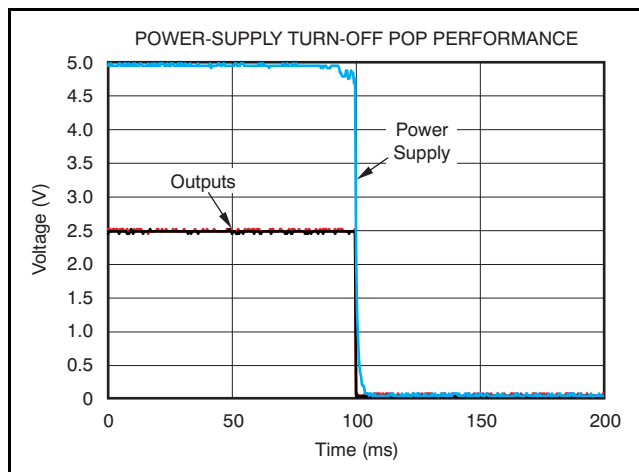

Figure 73. THS4521 Power-Supply Turn-Off Pop Performance

With no tone input, Figure 74 shows the pop performance using the PD pin to enable the THS4521, and Figure 75 shows performance using the PD pin to disable the device. Again, the transients during power on and off show that no audible pop should be heard. It should also be noted that the turn on/off times are faster using the PD pin technique.

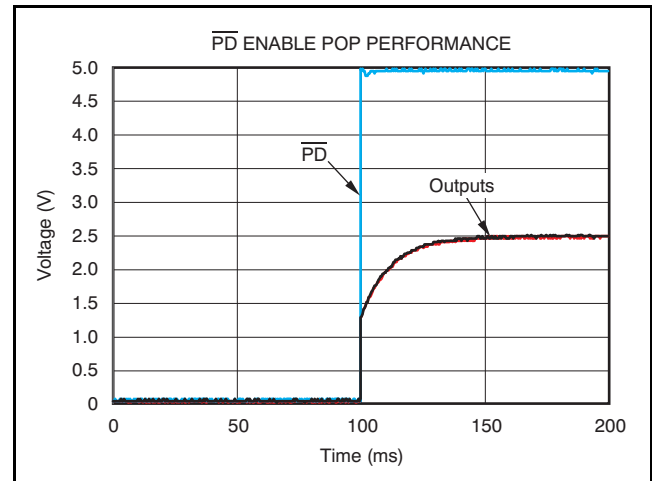

Figure 74. THS4521 PD Pin Enable Pop Performance

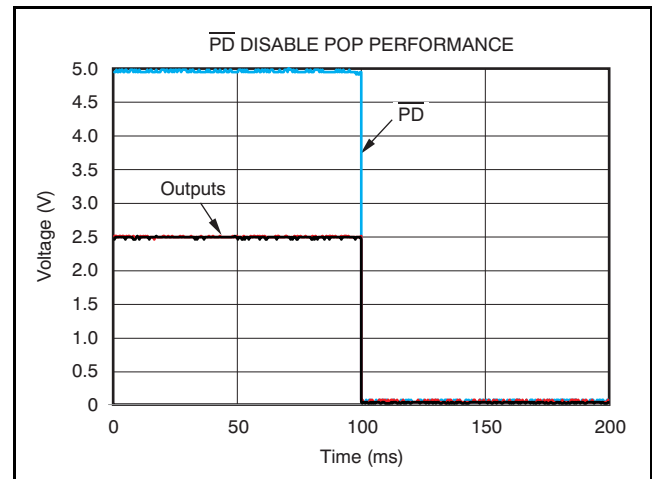

Figure 75. THS4521 PD Pin Disable Pop Performance

The power on/off pop performance of the THS4521, whether by switching the power supply or when using the power-down function built into the chip, shows that no special design should be required to prevent an audible pop.

Audio ADC Driver Performance: THS4521 and PCM4204 Combined Performance

To show achievable performance with a high-performance audio ADC, the THS4521 is tested as the drive amplifier for the [PCM4204](#). The PCM4204 is a high-performance, four-channel ADC designed for professional and broadcast audio applications. The PCM4204 architecture uses a 1-bit delta-sigma ($\Delta\Sigma$) modulator per channel that incorporates an advanced dither scheme for improved dynamic performance, and supports PCM output data. The PCM4204 provides a flexible serial port interface and many other advanced features. Refer to the [PCM4204 product data sheet](#) for more information.

The PCM4204EVM can test the audio performance of the THS4521 as a drive amplifier. The standard PCM4204EVM is provided with four [OPA1632](#) fully-differential amplifiers, which use the same device pinout as the THS4521. For testing, one of these amplifiers is replaced with a THS4521 device in same package (MSOP), and the power supply changes to a single-supply +5V. [Figure 78](#) shows the modifications made to the circuit. Note the resistor connecting the V_{OCM} input of the THS4521 to the input common-mode drive from the PCM4204 is shown removed and is optional; no performance change was noted with it connected or removed. The THS4521 is operated with a +5-V single-supply so the output common-mode defaults to +2.5 V as required at the input of the PCM4204. The EVM power connections were modified by connecting positive supply inputs,

+15 V, +5 VA and +5 VD, to a +5-V external power supply (EXT +3.3 was not used) and connecting –15 V and all ground inputs to ground on the external power supply. Note only one external +5-V supply was needed to power all devices on the EVM.

A SYS-2722 Audio Analyzer from Audio Precision (AP) provides an analog audio input to the EVM; the PCM-formatted digital output is read by the digital input on the AP.

Data were taken using a 256- f_s system clock to achieve $f_s = 48$ -kHz measurements, and audio output uses PCM format. Other data rates and formats are expected to show similar performance in line with that shown in the product data sheet.

[Figure 76](#) shows the THD+N vs Frequency response with no weighting; [Figure 77](#) shows an FFT of the output with 1-kHz input tone. Input signals to the PCM4204 for these tests is 0.5 dBFS. Dynamic range is also tested at –60 dBFS, $f_{IN} = 1$ kHz, and A-weighted. [Table 4](#) summarizes testing results using the THS4521 together with the PCM4204 versus typical data sheet performance measurements, and show that it make an excellent drive amplifier for this ADC.

The test circuit shown in [Figure 78](#) has a gain = 0.27 and attenuates the input signal. For applications that require higher gain, the circuit was modified to gains of $G = 1$, $G = 2$, and $G = 5$ by replacing the feedback resistors (R33 and R34) and re-tested to show performance.

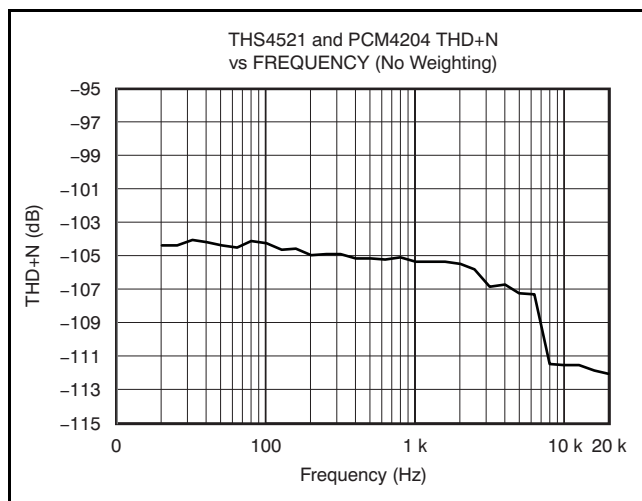

Figure 76. THS4521 and PCM4204: THD+N versus Frequency with No Weighting

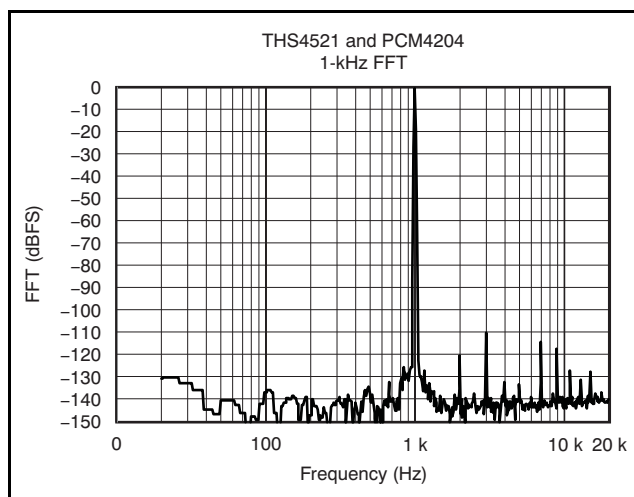

Figure 77. THS4521 and PCM4204 1-kHz FFT

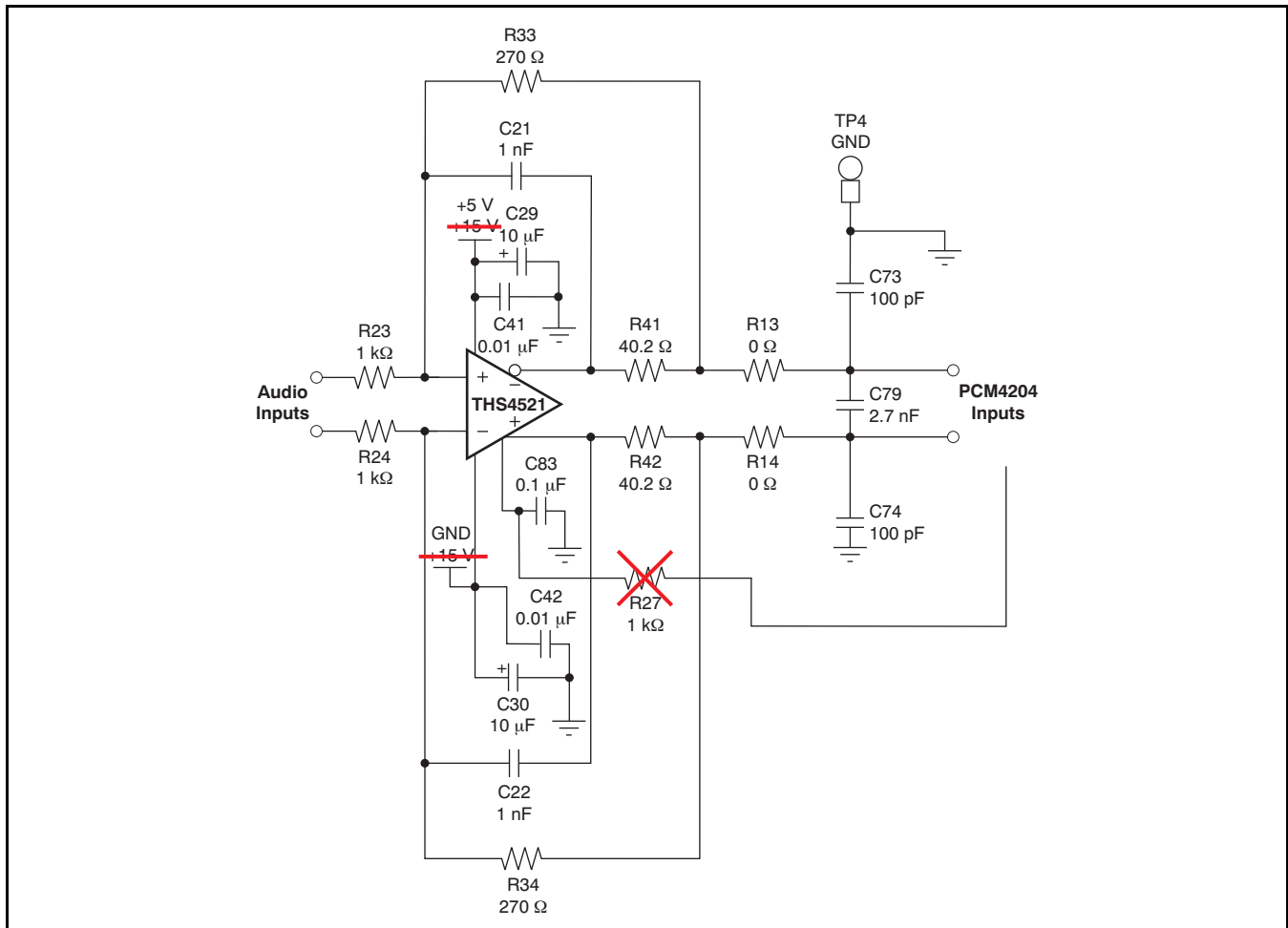

Figure 78. THS4521 and PCM4204 Test Circuit

Table 4. 1-kHz AC Analysis: Test Circuit versus PCM4204 Data Sheet Typical Specifications
 ($f_s = 48$ kSPS)

Configuration	Tone	THD+N	Dynamic Range
THS4521 and PCM4204	1 kHz	-106 dBc	117 dB
PCM4204 Data sheet (typ)	1 kHz	-105 dBc	118 dB

Figure 79 shows the THS4521 and PCM4204 THD+N versus frequency with no weighting at higher gains.

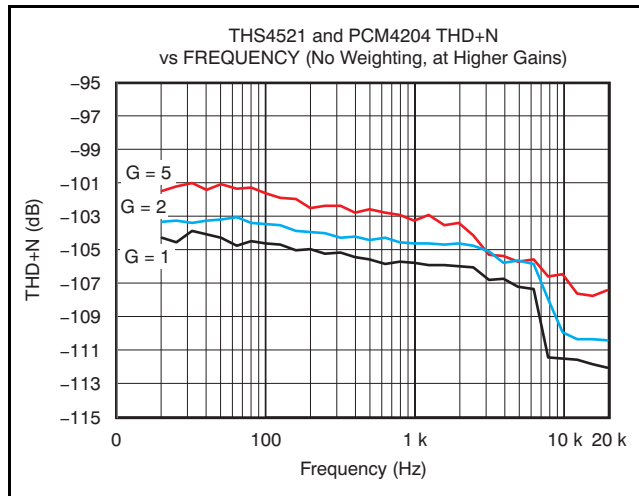

Figure 79. THS4521 and PCM4204: THD+N versus Frequency with No Weighting at Higher Gains

Audio ADC Driver Performance: THS4521 and PCM3168 Combined Performance

The THS4521 is also tested as the drive amplifier for the PCM3168A ADC input. The PCM3168A is a high-performance, single-chip, 24-bit, 6-in/8-out, audio coder/decoder (codec) with single-ended and differential selectable analog inputs and differential outputs. The six-channel, 24-bit ADC employs a $\Delta\Sigma$ modulator and supports 8-kHz to 96-kHz sampling rates and a 16-bit/24-bit width digital audio output word on the audio interface. The eight-channel, 24-bit digital-to-analog converter (DAC) employs a $\Delta\Sigma$ modulator and supports 8-kHz to 192-kHz sampling rates and a 16-bit/24-bit width digital audio input word on the audio interface. Each audio interface supports I²S™, left/right-justified, and DSP formats with 16-bit/24-bit word width. In addition, the PCM3168A supports the time-division-multiplexed (TDM) format. The PCM3168A provides flexible serial port interface and many other advanced features. Refer to the PCM3168A product data sheet for more information.

The PCM3168A EVM is used to test the audio performance of the THS4521 as a drive amplifier. The standard PCM3168A EVM is provided with OPA2134 op amps that are used to convert single-ended inputs to differential to drive the ADC. For testing, the op amp output series resistors are removed from one of the channels and a THS4521, mounted on its standard EVM, is connected to the ADC inputs via short coaxial cables. The THS4521

EVM is configured for both differential inputs as shown in Figure 60 and for single-ended input as shown in Figure 61 with 1-k Ω resistors for R_F and R_G, and 24.9- Ω resistors in series with each output to isolate the outputs from the reactive load of the coaxial cables. To limit the noise from the external EVM and cables, a 2.7-nF capacitor is placed differentially across the PCM3168A inputs. The THS4521 is operated with a single-supply +5-V supply so the output common-mode of the THS4521 defaults to +2.5 V as required at the input of the PCM3168A. The PCM3168A EVM is configured and operated as described in the PCM3168AEVM User Guide. The ADC was tested with an external THS4521 EVM with both single-ended input and differential inputs. In both configurations, the results are the same. Figure 80 shows the THD+N versus frequency and Table 5 compares the result to the PCM3168 data sheet typical specification at 1 kHz. Both graphs show that it makes an excellent drive amplifier for this ADC. **Note:** a 2700 series Audio Analyzer from Audio Precision is used to generate the input signals to the THS4521 and to analyze the digital data from the PCM3168.

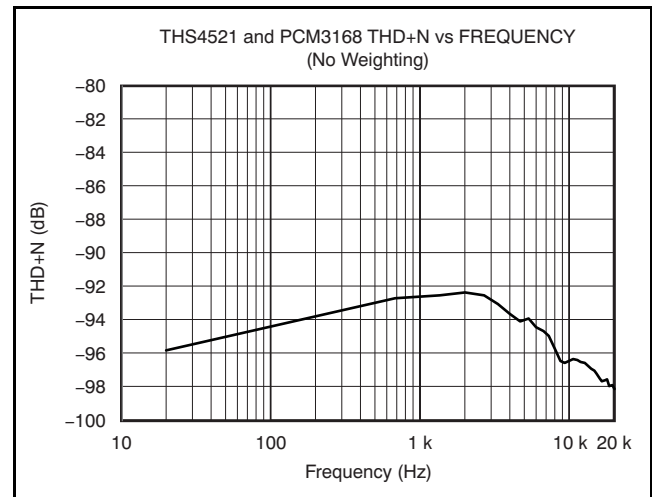

Figure 80. THS4521 and PCM3168: THD+N versus Frequency with No Weighting

Table 5. 1-kHz AC Analysis: Test Circuit vs PCM3168 Data Sheet Typical Specifications (f_s = 48 kSPS)

Configuration	Tone	THD+N
THS4521 and PCM3168	1 kHz	-92.6 dBc
PCM3168 Data sheet (typ)	1 kHz	-93 dBc

ADC Driver Performance: THS4521 and ADS1278 Combined Performance

The THS4521 provides excellent performance when driving high-performance $\Delta\Sigma$ and successive approximation register (SAR) ADCs in audio and industrial applications using a single 3-V to 5-V power supply. To show achievable performance, the THS4521 is tested as the drive amplifier for the ADS1278 24-bit ADC. The ADS1278 offers excellent ac and dc performance, with four selectable operating

modes from 10 kSPS to 128 kSPS to enable the user to fine-tune performance and power for specific application needs. The circuit shown in Figure 81 was used to test the performance. Data were taken using the High-Resolution mode (52 kSPS) of the ADS1278 with input frequencies at 1 kHz and 10 kHz and signal levels 1/2 dB below full-scale (–0.5 dBFS). FFT plots showing the spectral performance are given in Figure 82 and Figure 83; tabulated ac analysis results are shown in Table 6 and compared to the ADS1278 data sheet typical performance specifications.

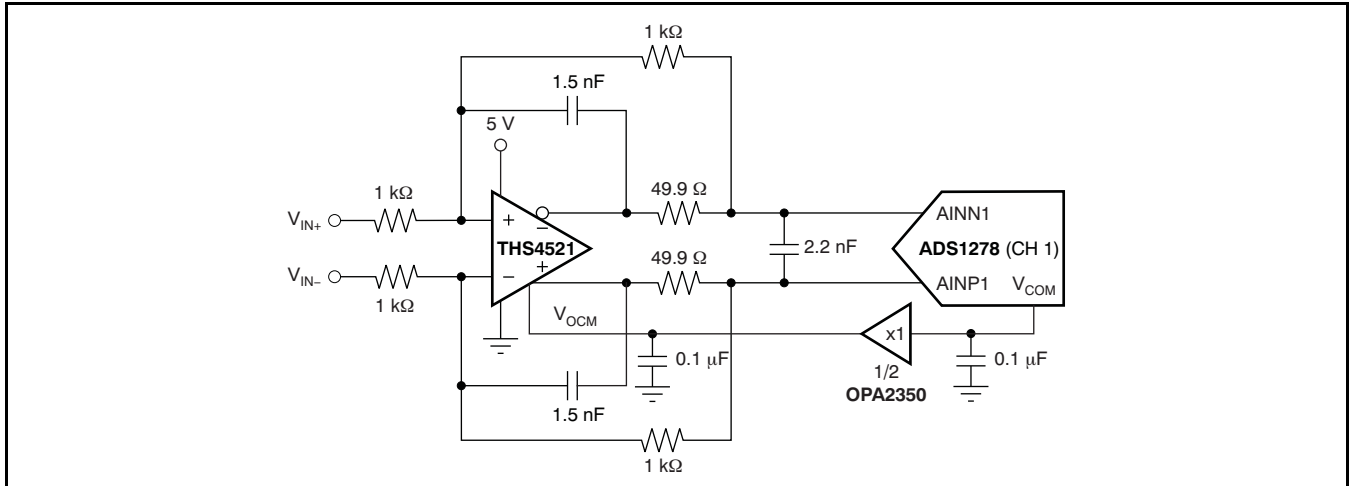

Figure 81. THS4521 and ADS1278 (Ch 1) Test Circuit

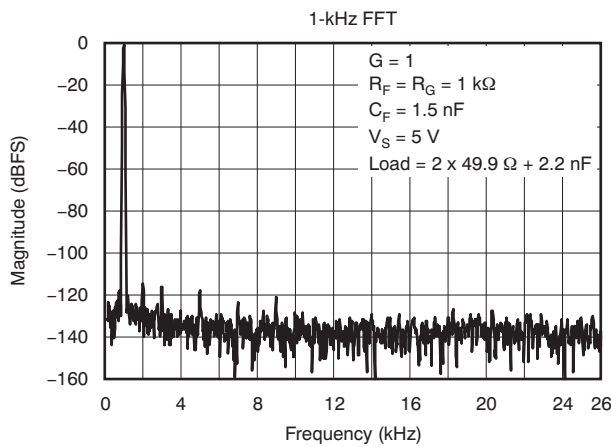

Figure 82. 1-kHz FFT

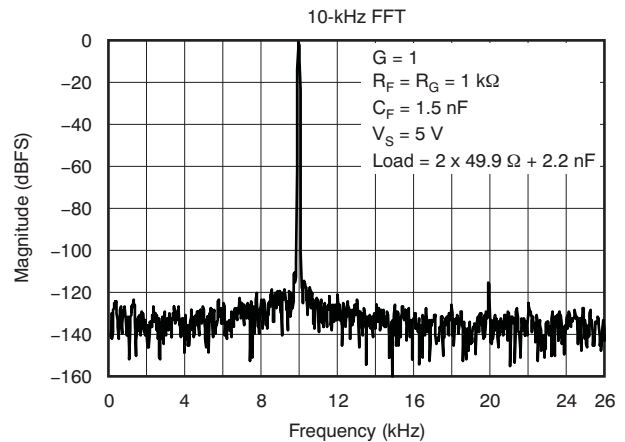

Figure 83. 10-kHz FFT

Table 6. AC Analysis

Configuration	Tone	Signal (dBFS)	SNR (dBc)	THD (dBc)	SINAD (dBc)	SFDR (dBc)
THS4521 and ADS1278	1 kHz	–0.5	109	–108	105	114
	10 kHz	–0.5	102	–110	101	110
ADS1278 Data sheet (typ)	1 kHz	–0.5	110	–108	—	109

**ADC Driver Performance:
THS4521 and ADS8321 Combined
Performance**

To demonstrate achievable performance, the THS4521 is tested as the drive amplifier for the ADS8321 16-bit SAR ADC. The ADS8321 offers excellent ac and dc performance, with ultra-low power and small size. The circuit shown in Figure 84 was used to test the performance.

Data were taken using the ADS8321 at 100 kSPS with input frequencies of 2 kHz and 10 kHz and signal levels that were -0.5 dBFS. FFT plots that illustrate the spectral performance are given in Figure 85 and Figure 86. Tabulated ac analysis results are listed in Table 7 and compared to the ADS8321 data sheet typical performance.

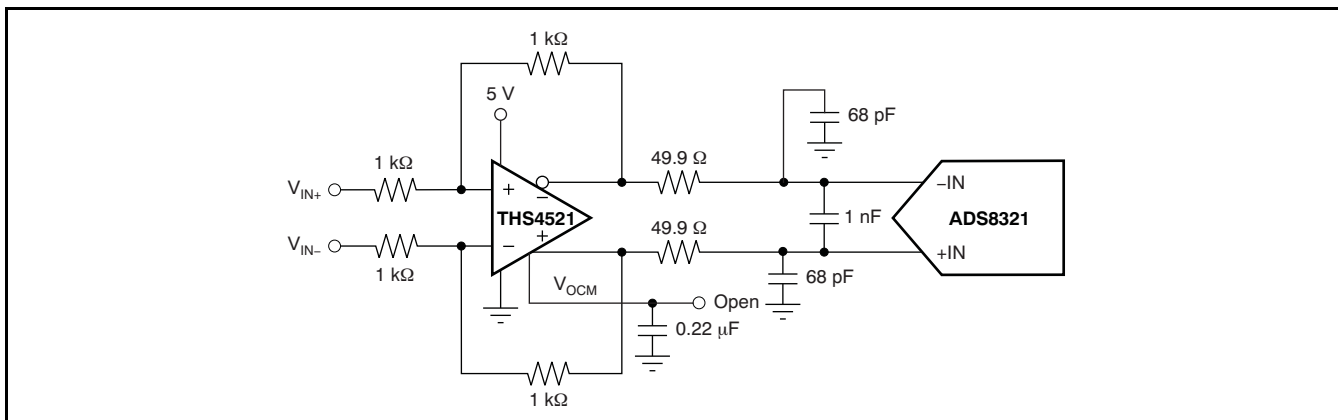

Figure 84. THS4521 and ADS8321 Test Circuit

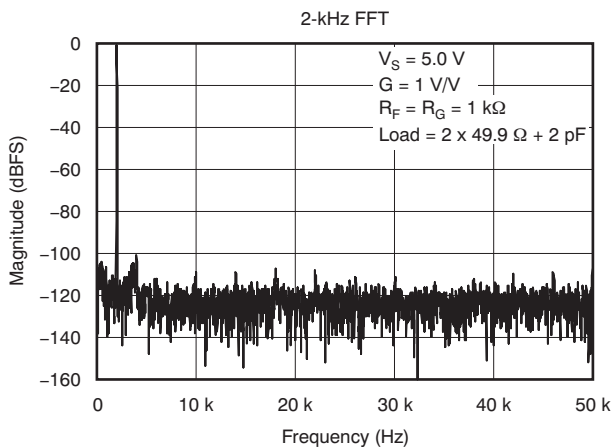

Figure 85. 2-kHz FFT

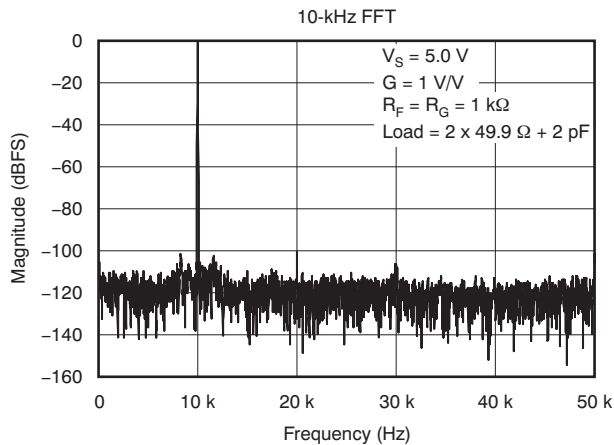

Figure 86. 10-kHz FFT

Table 7. AC Analysis

Configuration	Tone	Signal (dBFS)	SNR (dBc)	THD (dBc)	SINAD (dBc)	SFDR (dBc)
THS4521 and ADS8321	2 kHz	-0.5	86.7	-97.8	86.4	100.7
	10 kHz	-0.5	85.2	-98.1	85.2	102.2
ADS8321 Data sheet (typ)	10 kHz	-0.5	87	-86	84	86

EVM AND LAYOUT RECOMMENDATIONS

Figure 87 shows the THS4521EVM schematic. PCB layers 1 through 4 are shown in Figure 88; Table 8 lists the bill of materials for the THS4521EVM as supplied from TI. It is recommended to follow the layout of the external components near to the amplifier, ground plane construction, and power routing as closely as possible. Follow these general guidelines:

1. Signal routing should be direct and as short as possible into and out of the op amp circuit.
2. The feedback path should be short and direct.
3. Ground or power planes should be removed from directly under the amplifier input and output pins.
4. An output resistor is recommended in each output lead, placed as near to the output pins as possible.
5. Two 0.1- μ F power-supply decoupling capacitors should be placed as near to the power-supply pins as possible.
6. Two 10- μ F power-supply decoupling capacitors should be placed within 1 inch of the device and can be shared among multiple analog devices.
7. A 0.22- μ F capacitor should be placed between the V_{OCM} input pin and ground near to the pin. This capacitor limits noise coupled into the pin.
8. The \overline{PD} pin uses TTL logic levels; a bypass capacitor is not necessary if actively driven, but can be used for robustness in noisy environments whether driven or not.
9. If input termination resistors R_{10} and R_{11} are used, a single point connection to ground on L2 is recommended.

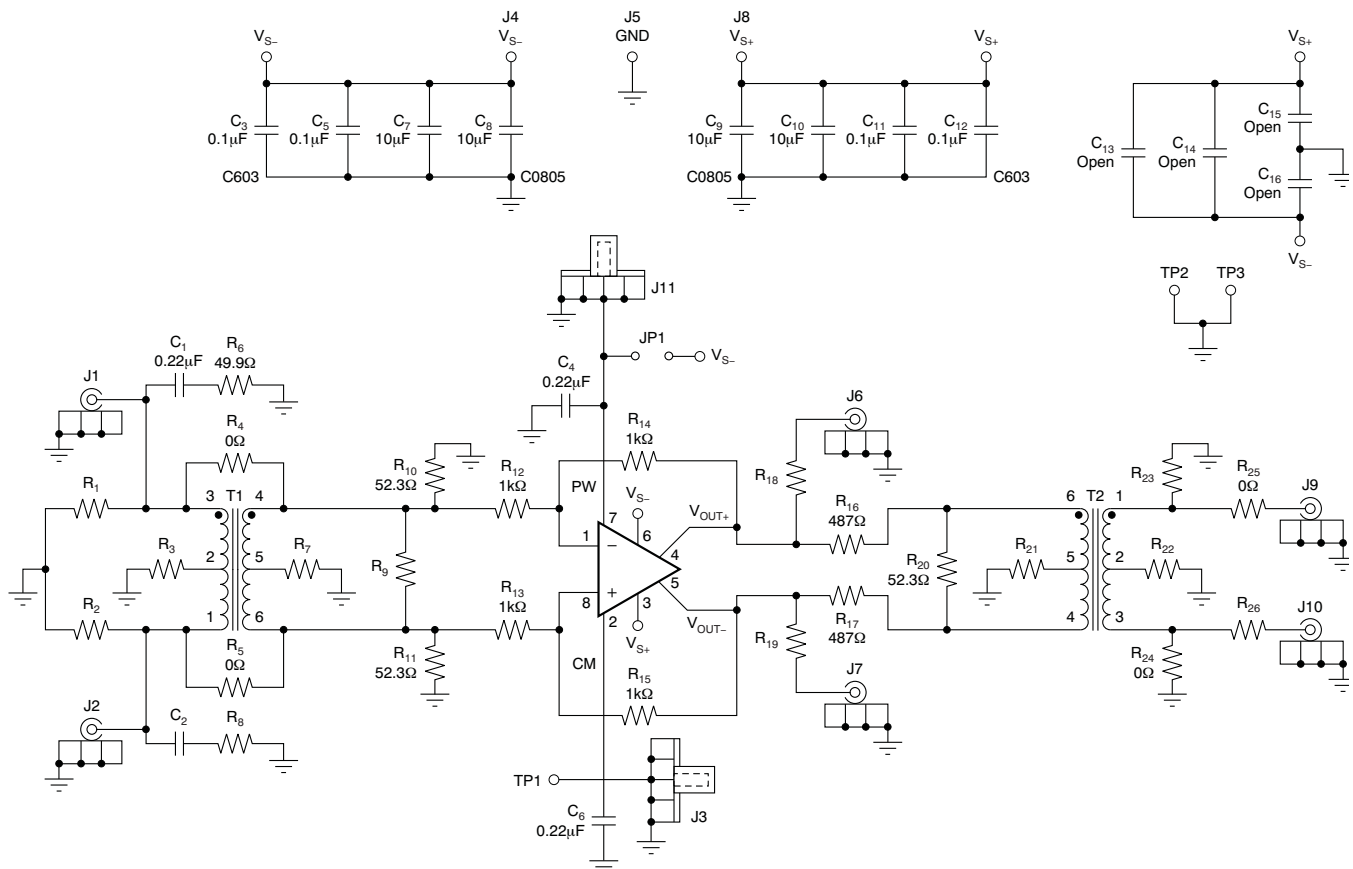

Figure 87. THS4521EVM: Schematic

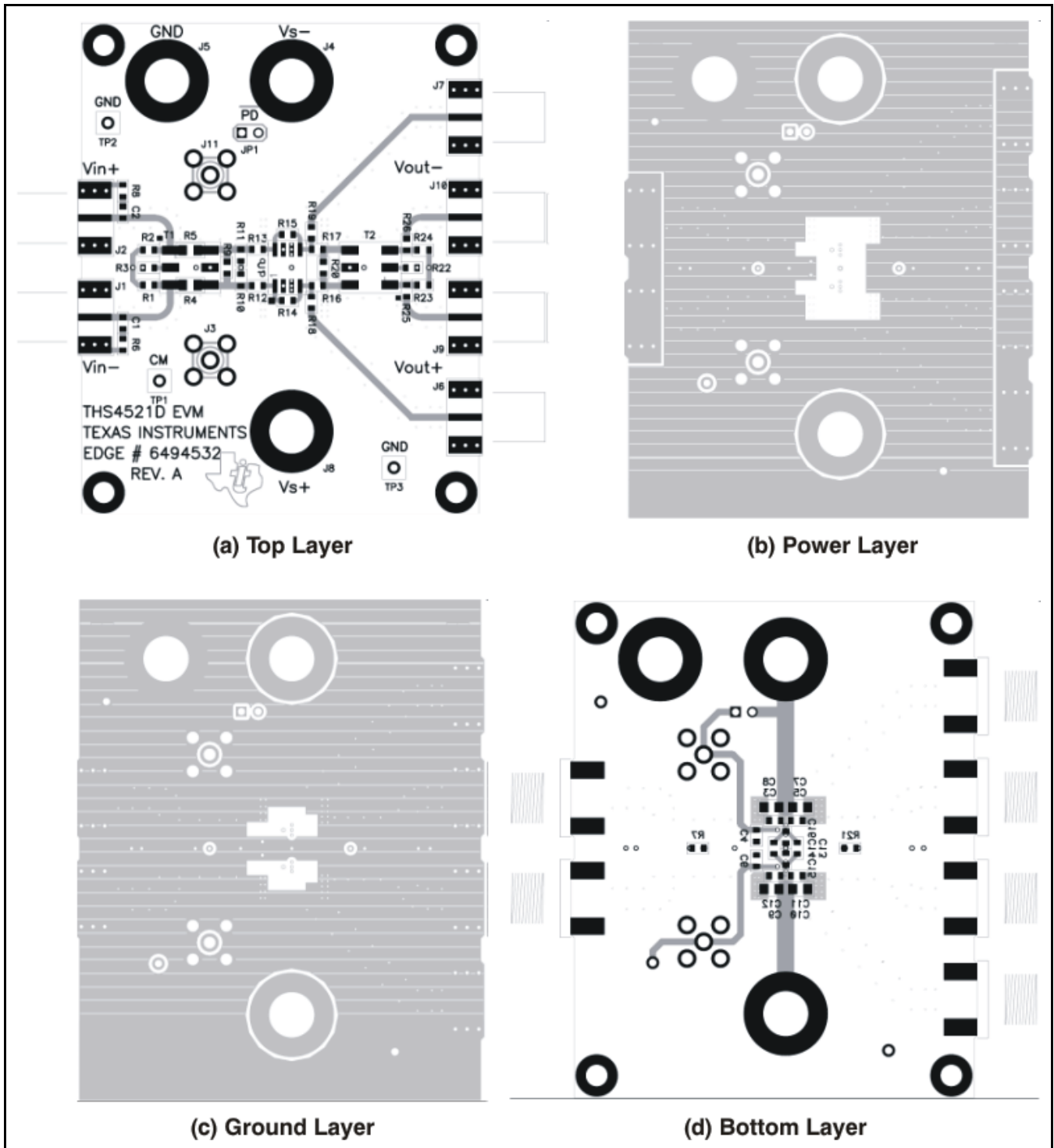

Figure 88. THS4521EVM: Layer 1 to Layer 4 Images

Table 8. THS4521EVM Parts List

ITEM	DESCRIPTION	SMD SIZE	REFERENCE DESIGNATOR	QTY	MANUFACTURER PART NUMBER
1	Capacitor, 10.0 μ F, ceramic, X5R, 6.3 V	0805	C7, C8, C9, C10	4	(AVX) 08056D106KAT2A
2	Capacitor, 0.1 μ F, ceramic, X7R, 16 V	0603	C3, C5, C11, C12	4	(AVX) 0603YC104KAT2A
3	Capacitor, 0.22 μ F, ceramic, X7R, 10 V	0603	C1, C4, C6	3	(AVX) 0603ZC224KAT2A
4	Open	0603	C2, C13, C14, C15, C16	5	
5	Open	0603	R1, R2, R3, R7, R8, R9, R18, R19, R21, R22, R23, R26	12	
6	Resistor, 0 Ω	0603	R24, R25	2	(ROHM) MCR03EZPJ000
7	Resistor, 49.9 Ω , 1/10W, 1%	0603	R6	1	(ROHM) MCR03EZPFX49R9
8	Resistor, 52.3 Ω , 1/10W, 1%	0603	R10, R11, R20	3	(ROHM) MCR03EZPFX52R3
9	Resistor, 487 Ω , 1/10W, 1%	0603	R16, R17	2	(ROHM) MCR03EZPFX4870
10	Resistor, 1k Ω , 1/10W, 1%	0603	R12, R13, R14, R15	4	(ROHM) MCR03EZPFX1001
11	Resistor, 0 Ω	0805	R4, R5	2	(ROHM) MCR10EZPJ000
12	Open		T1	1	
13	Transformer, RF		T2	1	(MINI-CIRCUITS) ADT1-1WT
14	Jack, Banana receptance, 0.25-in dia. hole		J4, J5, J8	3	(SPC) 813
15	Open		J1, J3, J6, J7, J10, J11	6	
16	Connector, edge, SMA PCB jack		J2, J9	2	(JOHNSON) 142-0701-801
17	Header, 0.1 in CTRS, 0.025-in sq. pins	2 POS.	JP1	1	(SULLINS) PBC36SAAN
18	Shunts		JP1	1	(SULLINS) SSC02SYAN
19	Test point, Red		TP1	1	(KEYSTONE) 5000
20	Test point, Black		TP2, TP3	2	(KEYSTONE) 5001
21	IC, THS4521		U1	1	(TI) THS4521D
22	Standoff, 4-40 hex, 0.625 in length			4	(KEYSTONE) 1808
23	Screw, Phillips, 4-40, .250 in			4	SHR-0440-016-SN
24	Board, printed circuit			1	(TI) EDGE# 6494532

REVISION HISTORY

NOTE: Page numbers for previous revisions may differ from page numbers in the current version.

Changes from Revision E (December 2010) to Revision F	Page
• Changed Input Offset Current values in 3.3 V Electrical Characteristics	3
• Changed Input Offset Current Drift values in 3.3 V Electrical Characteristics	3
• Changed Input Offset Current values in 5 V Electrical Characteristics	6
• Changed Input Offset Current Drift values in 5 V Electrical Characteristics	6
• Changed R41 and R42 in Figure 78	32
Changes from Revision D (August 2010) to Revision E	Page
• Changed test level indication for 5-V input offset voltage drift from B to C	5

Evaluation Board/Kit Important Notice

Texas Instruments (TI) provides the enclosed product(s) under the following conditions:

This evaluation board/kit is intended for use for **ENGINEERING DEVELOPMENT, DEMONSTRATION, OR EVALUATION PURPOSES ONLY** and is not considered by TI to be a finished end-product fit for general consumer use. Persons handling the product(s) must have electronics training and observe good engineering practice standards. As such, the goods being provided are not intended to be complete in terms of required design-, marketing-, and/or manufacturing-related protective considerations, including product safety and environmental measures typically found in end products that incorporate such semiconductor components or circuit boards. This evaluation board/kit does not fall within the scope of the European Union directives regarding electromagnetic compatibility, restricted substances (RoHS), recycling (WEEE), FCC, CE or UL, and therefore may not meet the technical requirements of these directives or other related directives.

Should this evaluation board/kit not meet the specifications indicated in the User's Guide, the board/kit may be returned within 30 days from the date of delivery for a full refund. **THE FOREGOING WARRANTY IS THE EXCLUSIVE WARRANTY MADE BY SELLER TO BUYER AND IS IN LIEU OF ALL OTHER WARRANTIES, EXPRESSED, IMPLIED, OR STATUTORY, INCLUDING ANY WARRANTY OF MERCHANTABILITY OR FITNESS FOR ANY PARTICULAR PURPOSE.**

The user assumes all responsibility and liability for proper and safe handling of the goods. Further, the user indemnifies TI from all claims arising from the handling or use of the goods. Due to the open construction of the product, it is the user's responsibility to take any and all appropriate precautions with regard to electrostatic discharge.

EXCEPT TO THE EXTENT OF THE INDEMNITY SET FORTH ABOVE, NEITHER PARTY SHALL BE LIABLE TO THE OTHER FOR ANY INDIRECT, SPECIAL, INCIDENTAL, OR CONSEQUENTIAL DAMAGES.

TI currently deals with a variety of customers for products, and therefore our arrangement with the user **is not exclusive**.

TI assumes **no liability for applications assistance, customer product design, software performance, or infringement of patents or services described herein.**

Please read the User's Guide and, specifically, the Warnings and Restrictions notice in the User's Guide prior to handling the product. This notice contains important safety information about temperatures and voltages. For additional information on TI's environmental and/or safety programs, please contact the TI application engineer or visit www.ti.com/esh.

No license is granted under any patent right or other intellectual property right of TI covering or relating to any machine, process, or combination in which such TI products or services might be or are used.

FCC Warning

This evaluation board/kit is intended for use for **ENGINEERING DEVELOPMENT, DEMONSTRATION, OR EVALUATION PURPOSES ONLY** and is not considered by TI to be a finished end-product fit for general consumer use. It generates, uses, and can radiate radio frequency energy and has not been tested for compliance with the limits of computing devices pursuant to part 15 of FCC rules, which are designed to provide reasonable protection against radio frequency interference. Operation of this equipment in other environments may cause interference with radio communications, in which case the user at his own expense will be required to take whatever measures may be required to correct this interference.

EVM Warnings and Restrictions

It is important to operate this EVM within the input voltage range of 3 V to 5.5 V and the output voltage range of 3 V to 5.5 V.

Exceeding the specified input range may cause unexpected operation and/or irreversible damage to the EVM. If there are questions concerning the input range, please contact a TI field representative prior to connecting the input power.

Applying loads outside of the specified output range may result in unintended operation and/or possible permanent damage to the EVM. Please consult the EVM User's Guide prior to connecting any load to the EVM output. If there is uncertainty as to the load specification, please contact a TI field representative.

During normal operation, some circuit components may have case temperatures greater than +85°C. The EVM is designed to operate properly with certain components above +85°C as long as the input and output ranges are maintained. These components include but are not limited to linear regulators, switching transistors, pass transistors, and current sense resistors. These types of devices can be identified using the EVM schematic located in the EVM User's Guide. When placing measurement probes near these devices during operation, please be aware that these devices may be very warm to the touch.

Mailing Address: Texas Instruments, Post Office Box 655303, Dallas, Texas 75265
Copyright © 2011, Texas Instruments Incorporated

PACKAGING INFORMATION

Orderable Device	Status ⁽¹⁾	Package Type	Package Drawing	Pins	Package Qty	Eco Plan ⁽²⁾	Lead/ Ball Finish	MSL Peak Temp ⁽³⁾	Samples (Requires Login)
THS4521ID	ACTIVE	SOIC	D	8	75	Green (RoHS & no Sb/Br)	CU NIPDAU	Level-2-260C-1 YEAR	
THS4521IDGKR	ACTIVE	MSOP	DGK	8	2500	Green (RoHS & no Sb/Br)	CU NIPDAU	Level-2-260C-1 YEAR	
THS4521IDGKT	ACTIVE	MSOP	DGK	8	250	Green (RoHS & no Sb/Br)	CU NIPDAU	Level-2-260C-1 YEAR	
THS4521IDR	ACTIVE	SOIC	D	8	2500	Green (RoHS & no Sb/Br)	CU NIPDAU	Level-2-260C-1 YEAR	
THS4522IPW	ACTIVE	TSSOP	PW	16	90	Green (RoHS & no Sb/Br)	CU NIPDAU	Level-2-260C-1 YEAR	
THS4522IPWR	ACTIVE	TSSOP	PW	16	2000	Green (RoHS & no Sb/Br)	CU NIPDAU	Level-2-260C-1 YEAR	
THS4524IDBT	ACTIVE	TSSOP	DBT	38	50	Green (RoHS & no Sb/Br)	CU NIPDAU	Level-2-260C-1 YEAR	
THS4524IDBTR	ACTIVE	TSSOP	DBT	38	2000	Green (RoHS & no Sb/Br)	CU NIPDAU	Level-2-260C-1 YEAR	

⁽¹⁾ The marketing status values are defined as follows:

ACTIVE: Product device recommended for new designs.

LIFEBUY: TI has announced that the device will be discontinued, and a lifetime-buy period is in effect.

NRND: Not recommended for new designs. Device is in production to support existing customers, but TI does not recommend using this part in a new design.

PREVIEW: Device has been announced but is not in production. Samples may or may not be available.

OBSOLETE: TI has discontinued the production of the device.

⁽²⁾ Eco Plan - The planned eco-friendly classification: Pb-Free (RoHS), Pb-Free (RoHS Exempt), or Green (RoHS & no Sb/Br) - please check <http://www.ti.com/productcontent> for the latest availability information and additional product content details.

TBD: The Pb-Free/Green conversion plan has not been defined.

Pb-Free (RoHS): TI's terms "Lead-Free" or "Pb-Free" mean semiconductor products that are compatible with the current RoHS requirements for all 6 substances, including the requirement that lead not exceed 0.1% by weight in homogeneous materials. Where designed to be soldered at high temperatures, TI Pb-Free products are suitable for use in specified lead-free processes.

Pb-Free (RoHS Exempt): This component has a RoHS exemption for either 1) lead-based flip-chip solder bumps used between the die and package, or 2) lead-based die adhesive used between the die and leadframe. The component is otherwise considered Pb-Free (RoHS compatible) as defined above.

Green (RoHS & no Sb/Br): TI defines "Green" to mean Pb-Free (RoHS compatible), and free of Bromine (Br) and Antimony (Sb) based flame retardants (Br or Sb do not exceed 0.1% by weight in homogeneous material)

⁽³⁾ MSL, Peak Temp. -- The Moisture Sensitivity Level rating according to the JEDEC industry standard classifications, and peak solder temperature.

Important Information and Disclaimer: The information provided on this page represents TI's knowledge and belief as of the date that it is provided. TI bases its knowledge and belief on information provided by third parties, and makes no representation or warranty as to the accuracy of such information. Efforts are underway to better integrate information from third parties. TI has taken and continues to take reasonable steps to provide representative and accurate information but may not have conducted destructive testing or chemical analysis on incoming materials and chemicals. TI and TI suppliers consider certain information to be proprietary, and thus CAS numbers and other limited information may not be available for release.

In no event shall TI's liability arising out of such information exceed the total purchase price of the TI part(s) at issue in this document sold by TI to Customer on an annual basis.

OTHER QUALIFIED VERSIONS OF THS4521 :

NOTE: Qualified Version Definitions:

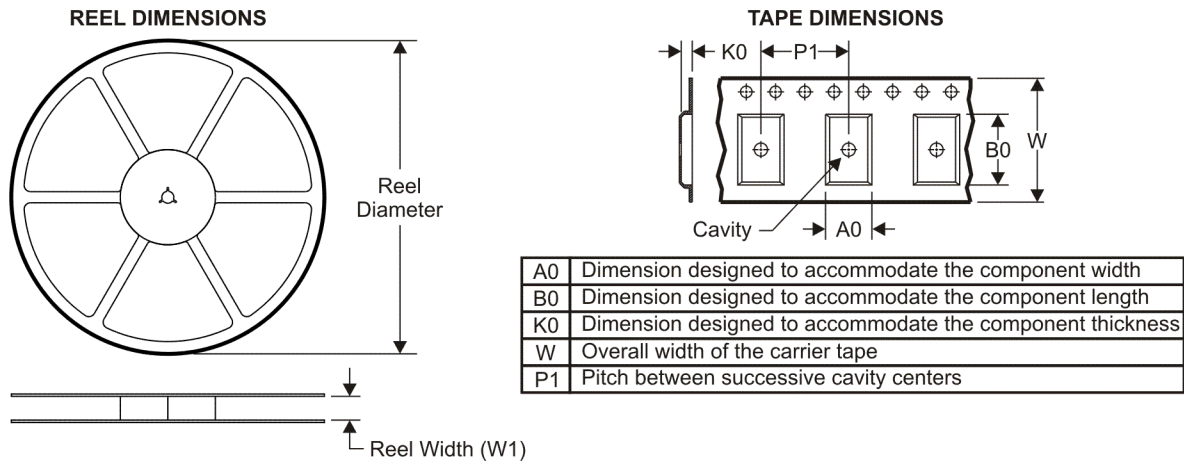
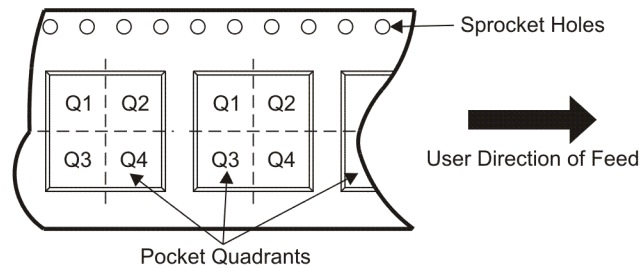
TAPE AND REEL INFORMATION

QUADRANT ASSIGNMENTS FOR PIN 1 ORIENTATION IN TAPE

*All dimensions are nominal

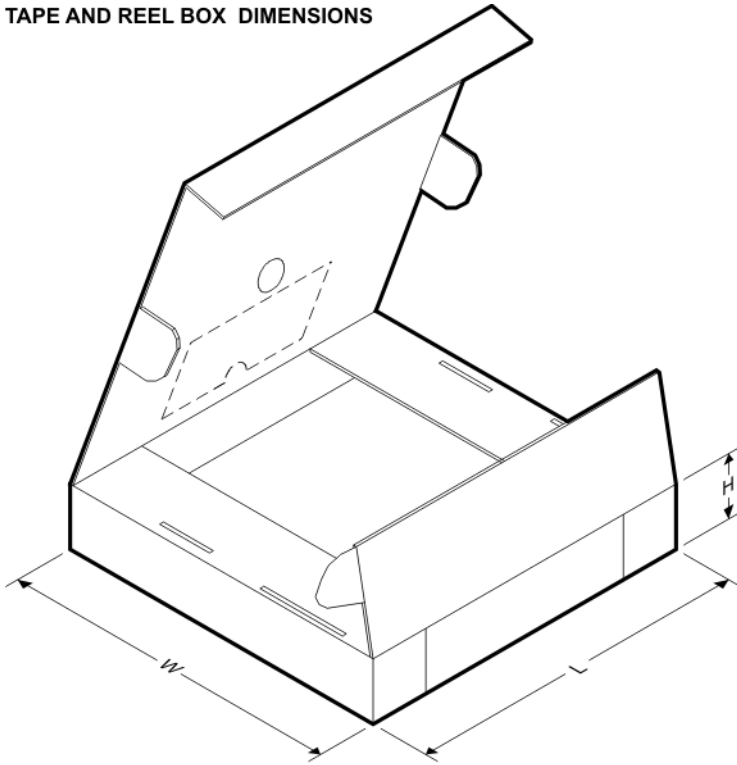
Device	Package Type	Package Drawing	Pins	SPQ	Reel Diameter (mm)	Reel Width W1 (mm)	A0 (mm)	B0 (mm)	K0 (mm)	P1 (mm)	W (mm)	Pin1 Quadrant
THS4521IDGKR	MSOP	DGK	8	2500	330.0	12.4	5.3	3.4	1.4	8.0	12.0	Q1
THS4521IDGKT	MSOP	DGK	8	250	180.0	12.4	5.3	3.4	1.4	8.0	12.0	Q1
THS4521IDR	SOIC	D	8	2500	330.0	12.4	6.4	5.2	2.1	8.0	12.0	Q1
THS4522IPWR	TSSOP	PW	16	2000	330.0	12.4	6.9	5.6	1.6	8.0	12.0	Q1
THS4524IDBTR	TSSOP	DBT	38	2000	330.0	16.4	6.9	10.2	1.8	12.0	16.0	Q1

TAPE AND REEL BOX DIMENSIONS

*All dimensions are nominal

Device	Package Type	Package Drawing	Pins	SPQ	Length (mm)	Width (mm)	Height (mm)
THS4521IDGKR	MSOP	DGK	8	2500	346.0	346.0	29.0
THS4521IDGKT	MSOP	DGK	8	250	190.5	212.7	31.8
THS4521IDR	SOIC	D	8	2500	346.0	346.0	29.0
THS4522IPWR	TSSOP	PW	16	2000	346.0	346.0	29.0
THS4524IDBTR	TSSOP	DBT	38	2000	346.0	346.0	33.0

DGK (S-PDSO-G8)

PLASTIC SMALL-OUTLINE PACKAGE

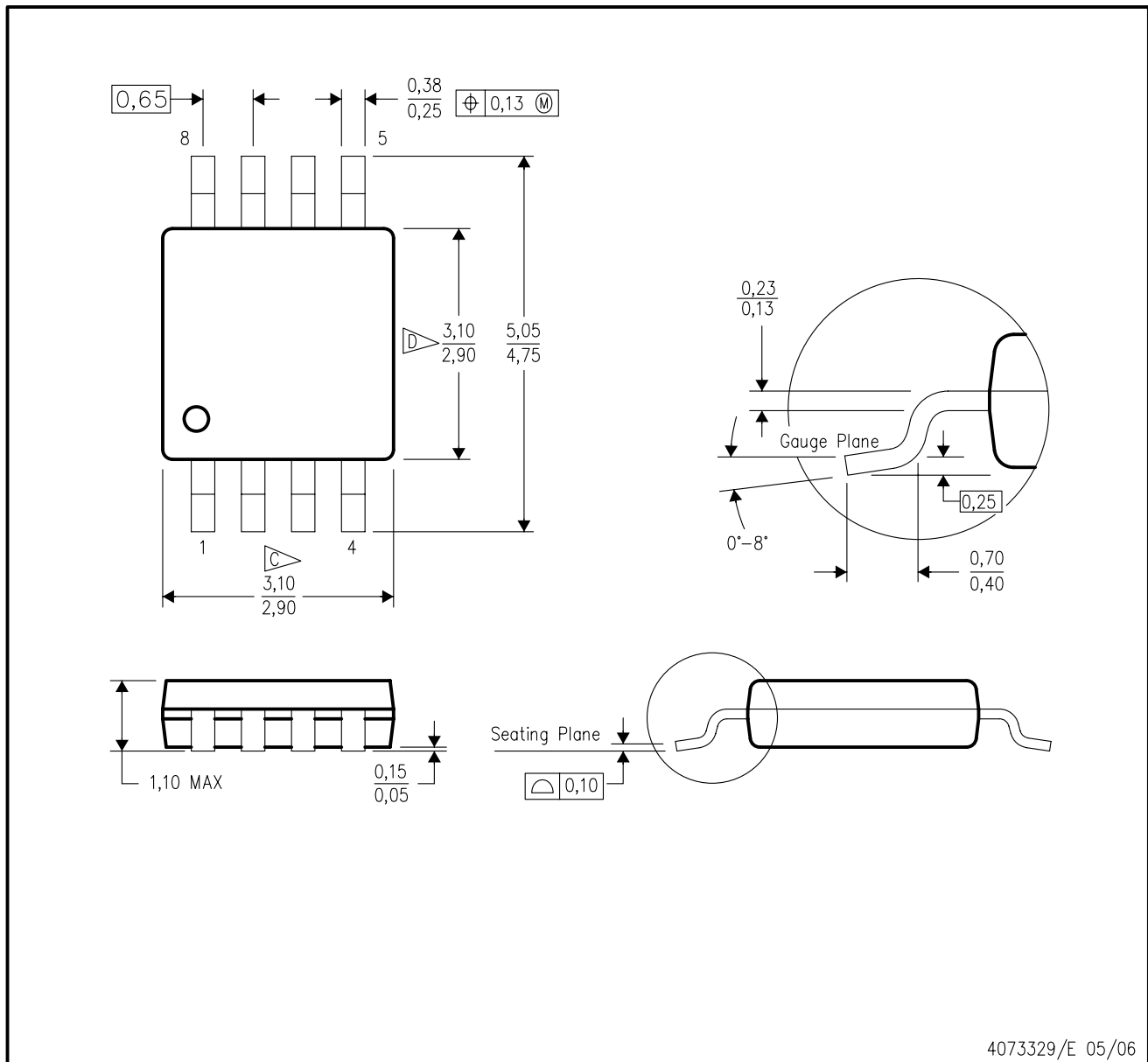

- NOTES:
- A. All linear dimensions are in millimeters.
 - B. This drawing is subject to change without notice.
 - C. Body length does not include mold flash, protrusions, or gate burrs. Mold flash, protrusions, or gate burrs shall not exceed 0.15 per end.
 - D. Body width does not include interlead flash. Interlead flash shall not exceed 0.50 per side.
 - E. Falls within JEDEC MO-187 variation AA, except interlead flash.

PW (R-PDSO-G16)

PLASTIC SMALL OUTLINE

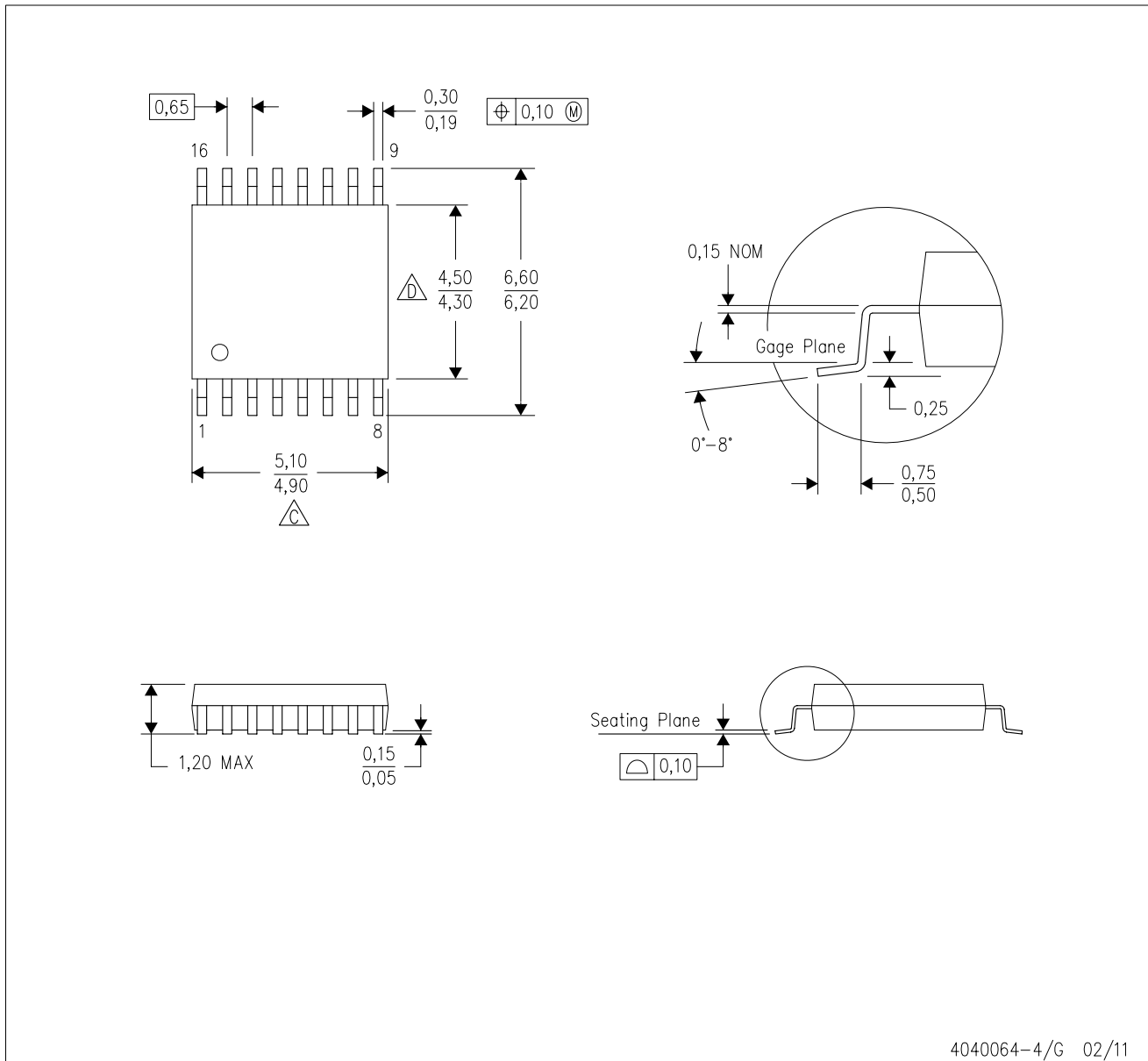

4040064-4/G 02/11

- NOTES:
- A. All linear dimensions are in millimeters. Dimensioning and tolerancing per ASME Y14.5M-1994.
 - B. This drawing is subject to change without notice.
 - C. Body length does not include mold flash, protrusions, or gate burrs. Mold flash, protrusions, or gate burrs shall not exceed 0,15 each side.
 - D. Body width does not include interlead flash. Interlead flash shall not exceed 0,25 each side.
 - E. Falls within JEDEC MO-153

MECHANICAL DATA

DBT (R-PDSO-G38)

PLASTIC SMALL OUTLINE

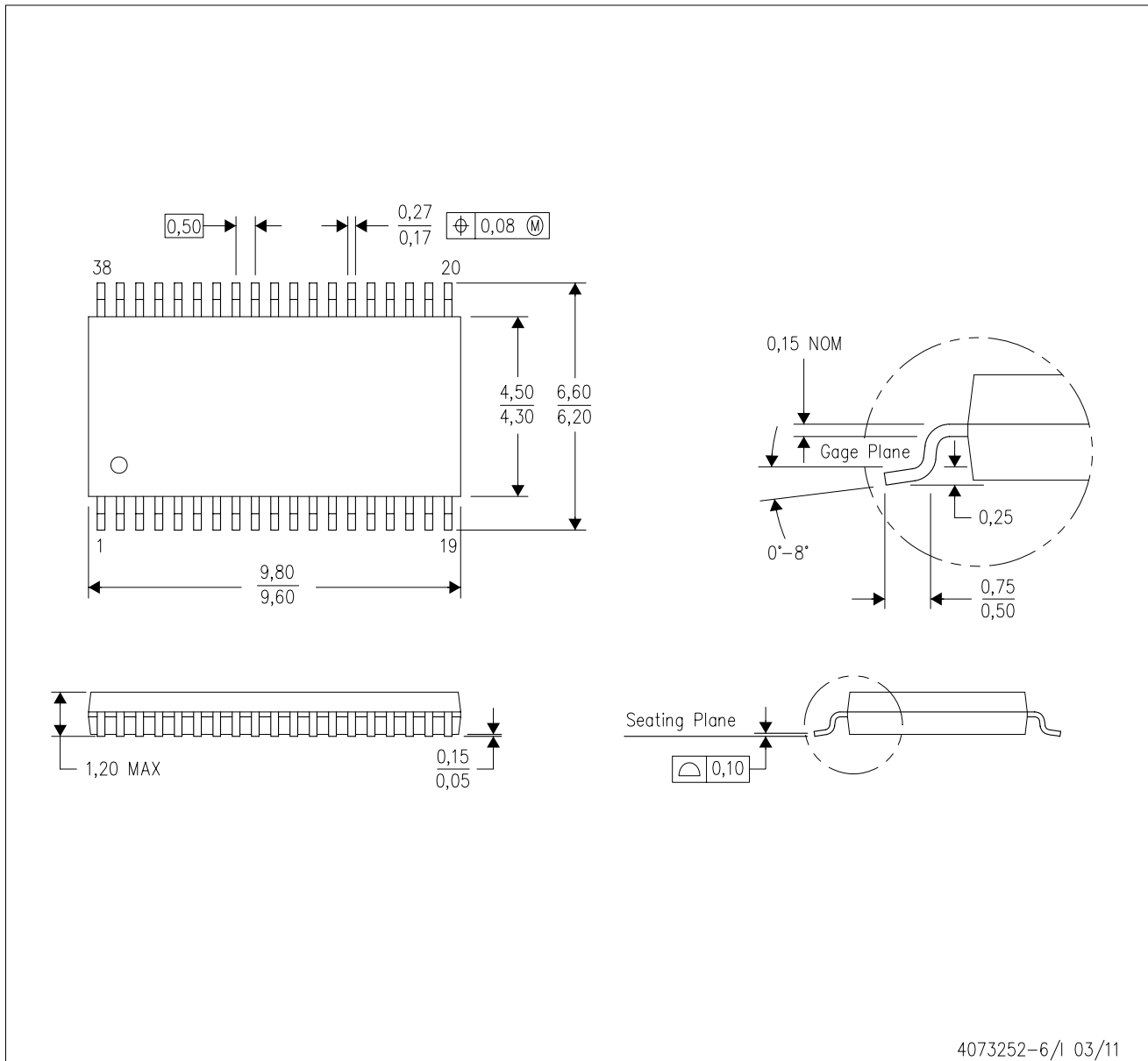

- NOTES:
- All linear dimensions are in millimeters. Dimensioning and tolerancing per ASME Y14.5M-1994.
 - This drawing is subject to change without notice.
 - Body dimensions do not include mold flash or protrusion.
 - Falls within JEDEC MO-153.

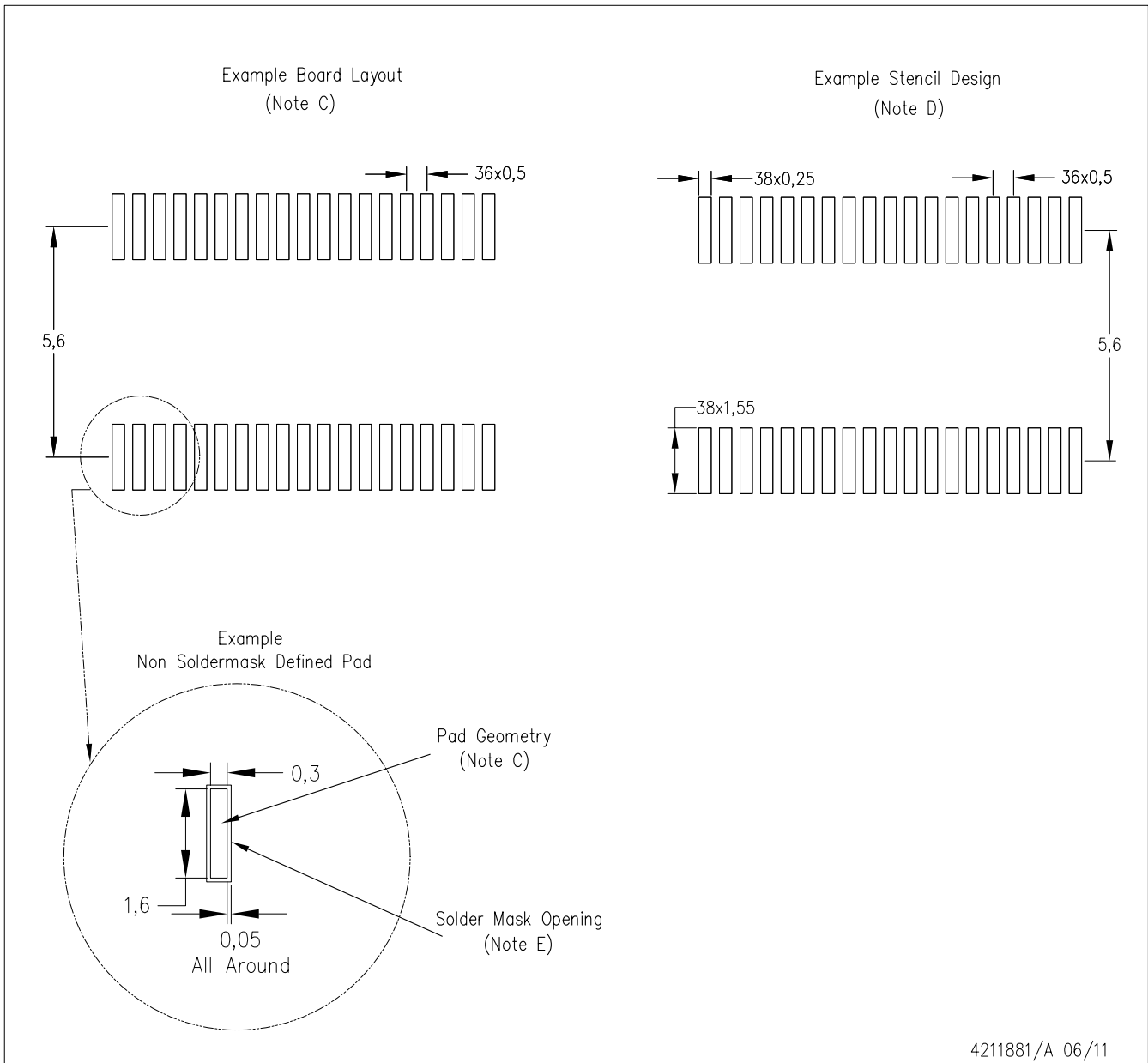

- NOTES:
- A. All linear dimensions are in millimeters.
 - B. This drawing is subject to change without notice.
 - C. Publication IPC-7351 is recommended for alternate designs.
 - D. Laser cutting apertures with trapezoidal walls and also rounding corners will offer better paste release. Customers should contact their board assembly site for stencil design recommendations. Refer to IPC-7525.
 - E. Customers should contact their board fabrication site for solder mask tolerances between and around signal pads.

D (R-PDSO-G8)

PLASTIC SMALL OUTLINE

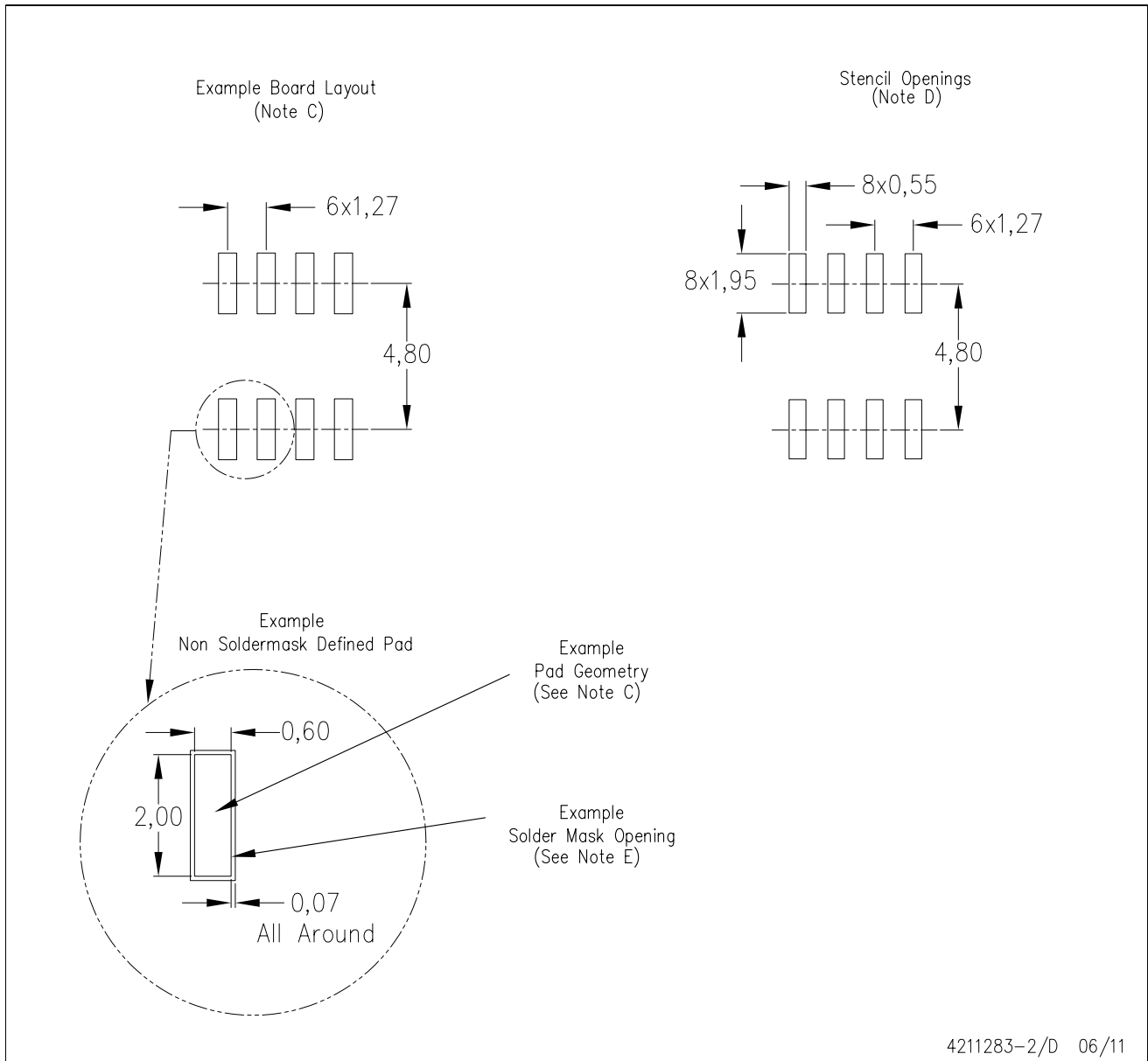

- NOTES:
- All linear dimensions are in millimeters.
 - This drawing is subject to change without notice.
 - Publication IPC-7351 is recommended for alternate designs.
 - Laser cutting apertures with trapezoidal walls and also rounding corners will offer better paste release. Customers should contact their board assembly site for stencil design recommendations. Refer to IPC-7525 for other stencil recommendations.
 - Customers should contact their board fabrication site for solder mask tolerances between and around signal pads.

IMPORTANT NOTICE

Texas Instruments Incorporated and its subsidiaries (TI) reserve the right to make corrections, modifications, enhancements, improvements, and other changes to its products and services at any time and to discontinue any product or service without notice. Customers should obtain the latest relevant information before placing orders and should verify that such information is current and complete. All products are sold subject to TI's terms and conditions of sale supplied at the time of order acknowledgment.

TI warrants performance of its hardware products to the specifications applicable at the time of sale in accordance with TI's standard warranty. Testing and other quality control techniques are used to the extent TI deems necessary to support this warranty. Except where mandated by government requirements, testing of all parameters of each product is not necessarily performed.

TI assumes no liability for applications assistance or customer product design. Customers are responsible for their products and applications using TI components. To minimize the risks associated with customer products and applications, customers should provide adequate design and operating safeguards.

TI does not warrant or represent that any license, either express or implied, is granted under any TI patent right, copyright, mask work right, or other TI intellectual property right relating to any combination, machine, or process in which TI products or services are used. Information published by TI regarding third-party products or services does not constitute a license from TI to use such products or services or a warranty or endorsement thereof. Use of such information may require a license from a third party under the patents or other intellectual property of the third party, or a license from TI under the patents or other intellectual property of TI.

Reproduction of TI information in TI data books or data sheets is permissible only if reproduction is without alteration and is accompanied by all associated warranties, conditions, limitations, and notices. Reproduction of this information with alteration is an unfair and deceptive business practice. TI is not responsible or liable for such altered documentation. Information of third parties may be subject to additional restrictions.

Resale of TI products or services with statements different from or beyond the parameters stated by TI for that product or service voids all express and any implied warranties for the associated TI product or service and is an unfair and deceptive business practice. TI is not responsible or liable for any such statements.

TI products are not authorized for use in safety-critical applications (such as life support) where a failure of the TI product would reasonably be expected to cause severe personal injury or death, unless officers of the parties have executed an agreement specifically governing such use. Buyers represent that they have all necessary expertise in the safety and regulatory ramifications of their applications, and acknowledge and agree that they are solely responsible for all legal, regulatory and safety-related requirements concerning their products and any use of TI products in such safety-critical applications, notwithstanding any applications-related information or support that may be provided by TI. Further, Buyers must fully indemnify TI and its representatives against any damages arising out of the use of TI products in such safety-critical applications.

TI products are neither designed nor intended for use in military/aerospace applications or environments unless the TI products are specifically designated by TI as military-grade or "enhanced plastic." Only products designated by TI as military-grade meet military specifications. Buyers acknowledge and agree that any such use of TI products which TI has not designated as military-grade is solely at the Buyer's risk, and that they are solely responsible for compliance with all legal and regulatory requirements in connection with such use.

TI products are neither designed nor intended for use in automotive applications or environments unless the specific TI products are designated by TI as compliant with ISO/TS 16949 requirements. Buyers acknowledge and agree that, if they use any non-designated products in automotive applications, TI will not be responsible for any failure to meet such requirements.

Following are URLs where you can obtain information on other Texas Instruments products and application solutions:

Products

Audio	www.ti.com/audio
Amplifiers	amplifier.ti.com
Data Converters	dataconverter.ti.com
DLP® Products	www.dlp.com
DSP	dsp.ti.com
Clocks and Timers	www.ti.com/clocks
Interface	interface.ti.com
Logic	logic.ti.com
Power Mgmt	power.ti.com
Microcontrollers	microcontroller.ti.com
RFID	www.ti-rfid.com
OMAP Mobile Processors	www.ti.com/omap
Wireless Connectivity	www.ti.com/wirelessconnectivity

Applications

Communications and Telecom	www.ti.com/communications
Computers and Peripherals	www.ti.com/computers
Consumer Electronics	www.ti.com/consumer-apps
Energy and Lighting	www.ti.com/energy
Industrial	www.ti.com/industrial
Medical	www.ti.com/medical
Security	www.ti.com/security
Space, Avionics and Defense	www.ti.com/space-avionics-defense
Transportation and Automotive	www.ti.com/automotive
Video and Imaging	www.ti.com/video

TI E2E Community Home Page

e2e.ti.com

Mailing Address: Texas Instruments, Post Office Box 655303, Dallas, Texas 75265
Copyright © 2011, Texas Instruments Incorporated