

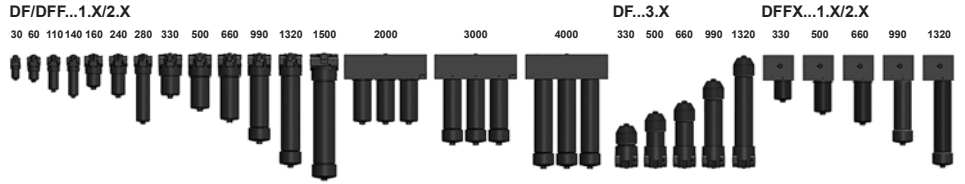

Pressure Filter DF Pressure Filter for Reversible Oil Flow DFF/DFFX up to 2000 l/min, up to 420 bar



1. TECHNICAL SPECIFICATIONS

1.1 FILTER HOUSING

Construction

The filter housings are designed in accordance with international regulations. They consist of a filter head and a screw-in filter bowl. DFF filters are suitable for flow in both directions. The Δp optimized filters DFFX are also suitable for flow in both directions and the filter ports are in L configuration. Standard equipment:

- connection for a clogging indicator in filter head
- drain screw with pressure relief (for size DF/DFF/DFFX 330 and above)
- 1 or 2-piece filter bowl available as an option for DF/DFF/DFFX 280-660 and DF 2000
- 2-piece filter bowl standard for size DF/DFF/DFFX 990 and above

1.2 FILTER ELEMENTS

HYDAC filter elements are validated and their quality is constantly monitored according to the following standards:

- ISO 2941, ISO 2942, ISO 2943, ISO 3724, ISO 3968, ISO 11170, ISO 16889

Contamination retention capacities in g

		Betamicon® (BN4HC)			
DF/DFF/ Elements		3 µm	5 µm	10 µm	20 µm
30	1x0030 D	4.6	5.1	5.4	5.6
60	1x0060 D	6.5	7.3	7.8	8.0
110	1x0110 D	13.8	15.5	16.4	16.9
140	1x0140 D	18.1	20.3	21.5	22.2
160	1x0160 D	19.8	22.2	23.5	24.3
240	1x0240 D	32.3	36.3	38.4	39.6
280	1x0280 D	70.6	79.3	83.9	86.6
330	1x0330 D	47.2	53.1	56.1	57.9
500	1x0500 D	76.9	86.5	91.5	94.4
660	1x0660 D	102.2	114.9	121.5	125.4
990	1x0990 D	154.5	173.7	183.7	189.5
1320	1x1320 D	209.9	236.0	249.6	257.5
1500	1x1500 D	220.0	226.0	238.0	246.0
2000	3x0660 D	306.6	344.7	364.5	376.2
3000	3x0990 D	463.5	521.1	551.1	568.5
4000	3x1320 D	629.7	708.0	748.8	772.5

Filter elements are available with the following pressure stability values:

Betamicon® (BN4HC):	20 bar
Betamicon® (BH4HC):	210 bar
Wire mesh (W):	20 bar
Stainless steel fibre (V):	210 bar

1.3 FILTER SPECIFICATIONS

Nominal pressure	420 bar
Fatigue strength	at nominal pressure 2x10 ⁶ cycles from 0 to nominal pressure (size 30 to 1320) 3x10 ⁵ cycles at 420 bar (size 1500) 3x10 ⁶ cycles at 280 bar (size 1500) 10 ⁶ cycles at 315 bar (size 2000-4000)
Temperature range	-30 °C to +100 °C (-30 °C to -10 °C: p _{max} = 210 bar)
Material of filter head	EN-GJS 400-15, ADI (size 330 - 1500)
Material of filter bowl	Steel
Type of clogging indicator	VD (differential pressure indication up to 420 bar operating pressure)
Pressure setting of clogging indicator	DF: 5 bar DFF/DFFX: 8 bar (others on request)
Cracking pressure of bypass only for size 30-1320 (optional)	6 bar (others on request)

		Betamicon® (BH4HC)			
DF/DFF/ Elements		3 µm	5 µm	10 µm	20 µm
30	1x0030 D	3.0	2.9	3.2	3.7
60	1x0060 D	4.6	4.5	5.0	5.7
110	1x0110 D	10.1	9.9	10.9	12.4
140	1x0140 D	13.3	13.0	14.3	16.3
160	1x0160 D	12.9	12.6	13.9	15.9
240	1x0240 D	21.6	21.1	23.2	26.5
280	1x0280 D	48.1	47.1	51.8	59.1
330	1x0330 D	34.6	33.9	37.2	42.5
500	1x0500 D	57.5	56.3	61.8	70.5
660	1x0660 D	76.8	75.2	82.6	94.3
990	1x0990 D	111.8	109.4	120.2	137.2
1320	1x1320 D	153.8	150.7	165.5	188.8
1500	1x1500 D	126.4	137.8	160.9	195.3
2000	3x0660 D	230.4	225.6	247.8	282.9
3000	3x0990 D	335.4	328.2	360.6	411.6
4000	3x1320 D	461.4	452.1	496.5	566.4

1.4 SEALS

NBR (= Perbunan)

1.5 INSTALLATION

As inline filter with or without reversible oil flow

1.6 SPECIAL MODELS AND ACCESSORIES

- Seals in FPM, EPDM
- With bypass valve (only DF filter)
- Oil drain screw, up to DF/DFF 280
- In ADI material
- for high duty cycle (DF/DFF 330-1500)
- Element top-removable -
TKZ 3.X (only DF filters 330 - 1320)
- Δp -optimized filter (only DFFX filter 330-1320)

1.7 SPARE PARTS

See Original Spare Parts List

1.8 CERTIFICATES AND APPROVALS

On request

1.9 COMPATIBILITY WITH HYDRAULIC FLUIDS ISO 2943

- Hydraulic oils H to HLPD DIN 51524
- Lubrication oils DIN 51517, API, ACEA, DIN 51515, ISO 6743
- Compressor oils DIN 51506
- Biodegradable operating fluids VDMA 24568 HETG, HEES, HEPG
- Fire-resistant fluids HFA, HFB, HFC and HFD
- Operating fluids with high water content (>50% water content) on request

1.10 IMPORTANT INFORMATION

- Filter housings must be earthed.
- When using electrical clogging indicators, the electrical power supply to the system must be switched off before removing the clogging indicator connector.

Symbol for hydraulic systems

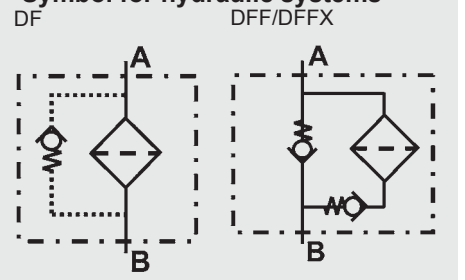

2. MODEL CODE (also order example)

DF BN/HC 1500 T L L 10 D 1 . X /-L24

2.1 COMPLETE FILTER

Filter type

DF, DFF, DFFX

Filter material

BN/HC Betamicon® (BN4HC) W Wire mesh
 BH/HC Betamicon® (BH4HC) V Stainless steel fibre

Size of filter or element

DF: 30, 60, 110, 140, 160, 240, 280, 330, 500, 660, 990, 1320, 1500, 2000, 3000, 4000
 DFF: 60, 110, 140, 160, 240, 280, 330, 500, 660, 990, 1320, 1500
 DFFX: 330, 500, 660, 990, 1320

Operating pressure

T 420 bar

Head design

no details inline filter ports (not possible for DFFX filters)
 L filter ports in L configuration (only DF/DFF 1500 and for all DFFX filters)

Type and size of connection

Type	Connection type	Filter size																
		30	60	110	140	160	240	280	330	500	660	990	1320	1500	2000	3000	4000	
B	G ½	•																
C	G ¾		•	•	•													
E	G1 ¼					•	•	•										
F	G1 ½								•	•	•	•	•					
G	G2													•				
I	SAE DN 20		•	•	•													
J	SAE DN 32					•	•	•										
L	SAE DN 50								•	•	•	•	•	•	•	•	•	•
N	SAE DN 80														•	•	•	•

• Preferred models

Filtration rating in µm

BN/HC, BH/HC, V: 3, 5, 10, 20 W: 25, 50, 100, 200

Type of clogging indicator

Y plastic blanking plug in indicator port
 A steel blanking plug in indicator port
 B visual
 C electrical
 D visual and electrical } for other clogging indicators, see brochure no. 7.050../..

Type code (TKZ)

1 one-piece filter bowl (up to DF/DFF/DFFX 660; DF 2000)
 2 two-piece filter bowl (size DF/DFF/DFFX 280)
 3 element top-removable (only DF 330 - 1320)

Modification number

X the latest version is always supplied

Supplementary details

ADI ADI material - for high duty cycle (only DF/DFF 330 - 1500)
 B. bypass cracking pressure (e.g. B6 = 6 bar); without details = without bypass valve
 L... light with appropriate voltage (24V, 48V, 110V, 220V)
 LED 2 light emitting diodes up to 24 Volt type "D" } only for clogging indicators
 P26 with 26" element (only DF/DFF 1500)
 P39 with 39" element (only DF/DFF 1500)
 SO184 pressure release/oil drain screw (standard for size DF/DFF 330 and above)
 V FPM seals
 W suitable for HFA, HFC oil-water emulsions (only necessary when using a clogging indicator or V or W elements)

2.2 REPLACEMENT ELEMENT

1500 D 010 BN4HC /-V

Size

0030, 0060, 0110, 0140, 0160, 0240, 0280, 0330, 0500, 0660, 0990, 1320, 1500

Type

D

Filtration rating in µm

BN4HC, BH4HC, V: 003, 005, 010, 020
 W: 025, 050, 100, 200

Filter material

BN4HC, BH4HC, W, V

Supplementary details

P26, P39, V, W (for descriptions, see Point 2.1)

2.3 REPLACEMENT CLOGGING INDICATOR

VD 5 D . X /-L24

Type

VD Differential pressure indicator up to 420 bar operating pressure

Pressure setting

5 standard for DF filter: 5 bar
 8 standard for DFF/DFFX filters: 8 bar } others on request

Type of clogging indicator (see Point 2.1)

Modification number

X the latest version is always supplied

Supplementary details

L..., LED, V, W (for descriptions, see point 2.1)

3. FILTER CALCULATION / SIZING

The total pressure drop of a filter at a certain flow rate Q is the sum of the housing Δp and the element Δp and is calculated as follows:

$$\Delta p_{\text{total}} = \Delta p_{\text{housing}} + \Delta p_{\text{element}}$$

$$\Delta p_{\text{housing}} = (\text{see Point 3.1})$$

$$\Delta p_{\text{element}} = Q \cdot \frac{SK^*}{1000} \cdot \frac{\text{viscosity}}{30}$$

(*see Point 3.2)

For ease of calculation, our Filter Sizing Program is available on request free of charge.

NEW: Sizing online at www.hydac.com

3.1 Δp -Q HOUSING CURVES BASED ON ISO 3968

The housing curves apply to mineral oil with a density of 0.86 kg/dm³ and a kinematic viscosity of 30 mm²/s. In this case, the differential pressure changes proportionally to the density.

DF 30

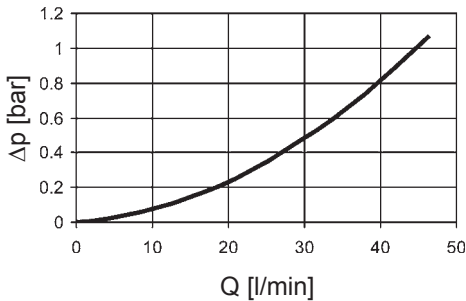

DF 60, 110, 140

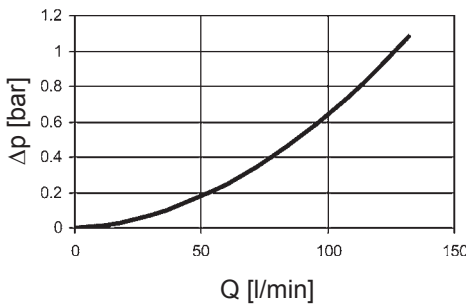

DF 160, 240, 280

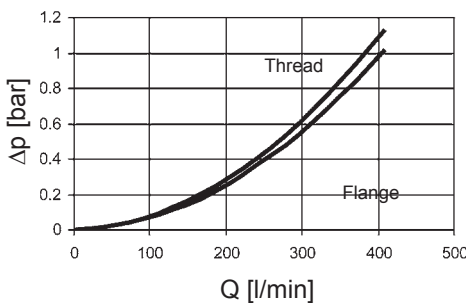

DF 330, 500, 660, 990, 1320

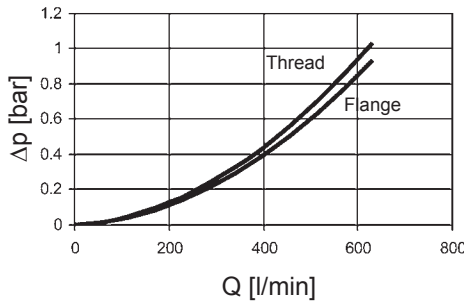

DF 1500

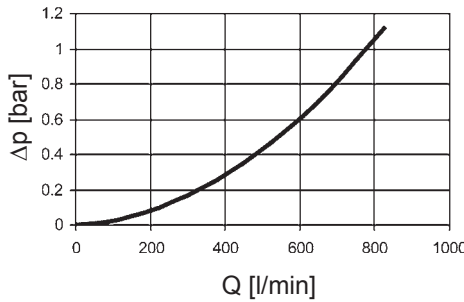

DF 2000, 3000, 4000

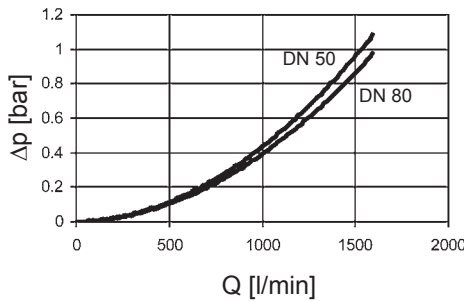

DFF 60, 110, 140

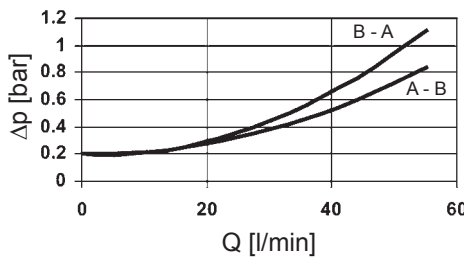

DFF 160, 240, 280

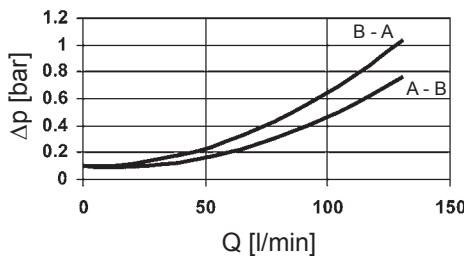

DFF 330, 500, 660, 990, 1320

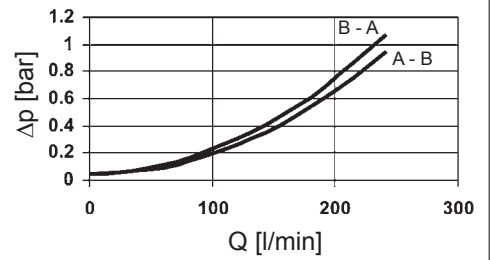

DFF 1500

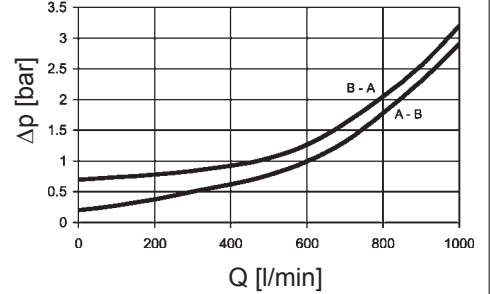

Δp optimized DFFX 330, 500, 660, 990, 1320

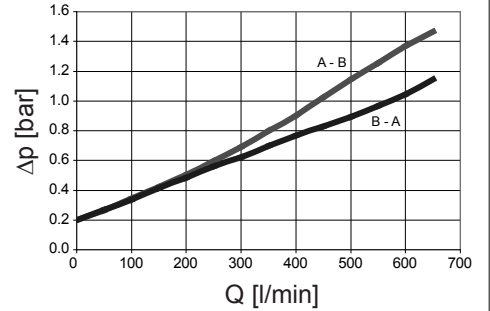

3.2 GRADIENT COEFFICIENTS (SK) FOR FILTER ELEMENTS

The gradient coefficients in mbar/(l/min) apply to mineral oils with a kinematic viscosity of 30 mm²/s. The pressure drop changes proportionally to the change in viscosity.

DF/DFV/ DFFX	V				W	BH4HC			
	3 μm	5 μm	10 μm	20 μm	–	3 μm	5 μm	10 μm	20 μm
30	18.4	13.5	7.5	3.6	3.030	91.2	50.7	36.3	19.0
60	16.0	9.3	5.4	3.3	0.757	58.6	32.6	18.1	12.2
110	8.2	5.6	3.3	2.2	0.413	25.4	14.9	8.9	5.6
140	5.8	4.8	3.1	2.3	0.324	19.9	11.3	8.1	4.3
160	4.6	3.2	2.3	1.4	0.284	16.8	10.4	5.9	4.4
240	3.1	2.5	1.7	1.1	0.189	10.6	6.8	3.9	2.9
280	2.3	1.7	1.2	0.8	0.162	5.7	3.4	1.8	1.6
330	2.2	1.8	1.2	0.8	0.138	7.7	4.5	2.8	2.0
500	1.5	1.2	0.8	0.5	0.091	4.2	2.6	1.5	1.2
660	1.1	0.9	0.6	0.4	0.069	3.3	1.9	1.0	0.9
990	0.8	0.6	0.4	0.3	0.046	2.2	1.3	0.8	0.6
1320	0.6	0.5	0.3	0.2	0.035	1.6	1.0	0.6	0.4
1500	–	–	–	–	–	1.4	0.8	0.6	0.5

BN4HC: 30

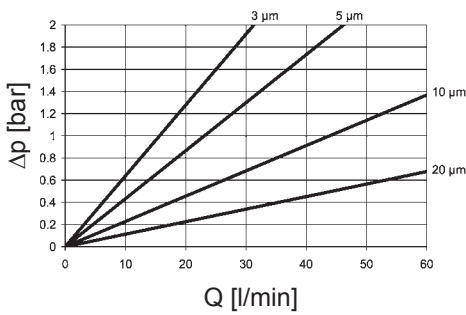

BN4HC: 60

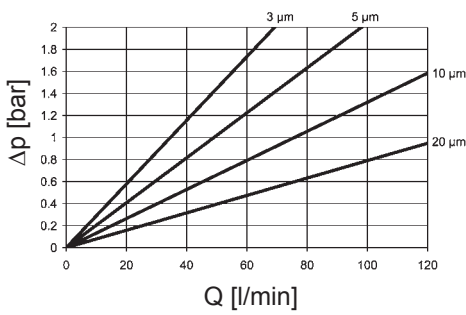

BN4HC: 110

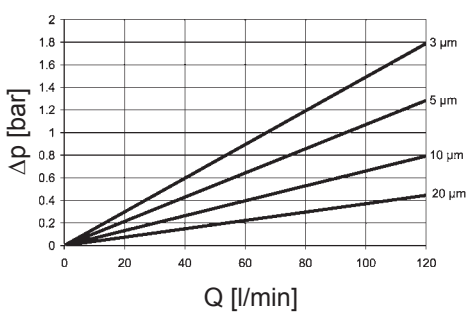

BN4HC: 140

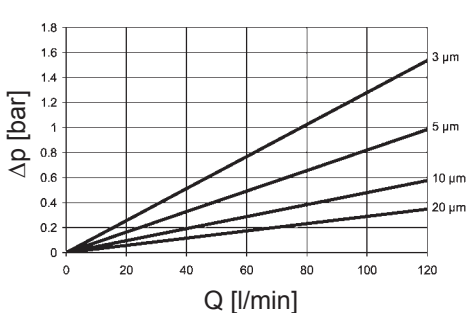

BN4HC: 160

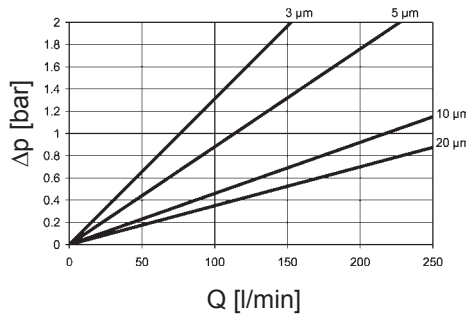

BN4HC: 240

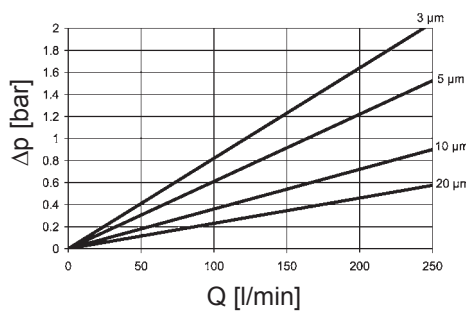

BN4HC: 280

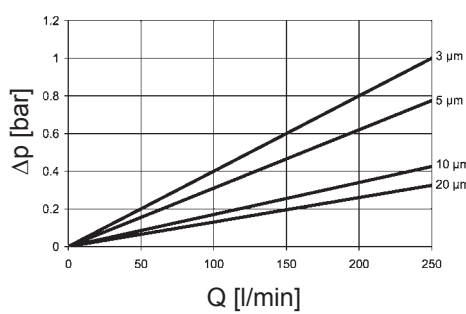

BN4HC: 330

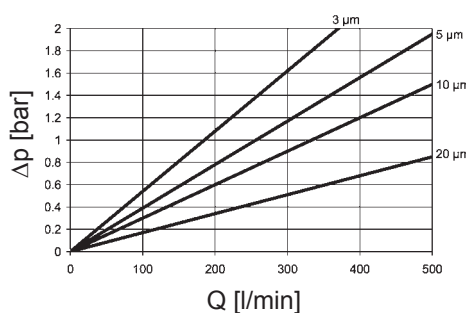

BN4HC: 500

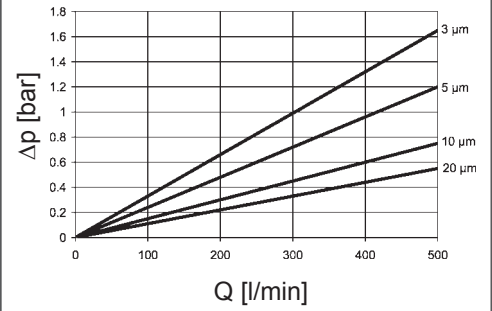

BN4HC: 660

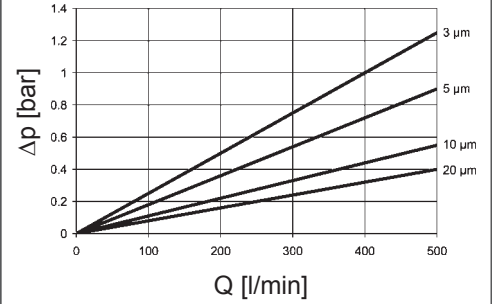

BN4HC: 990

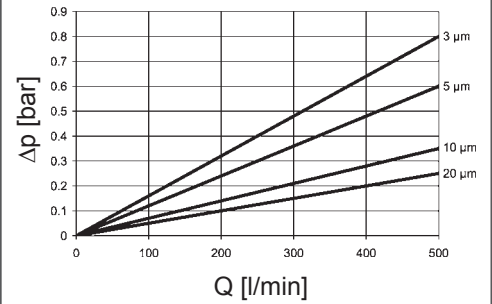

BN4HC: 1320

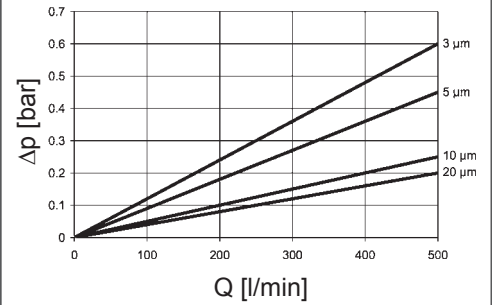

BN4HC: 1500

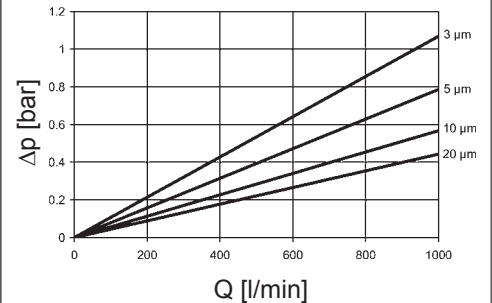

4. DIMENSIONS

DF 30, DF/DFE 60 to 1500 (inline filter ports)

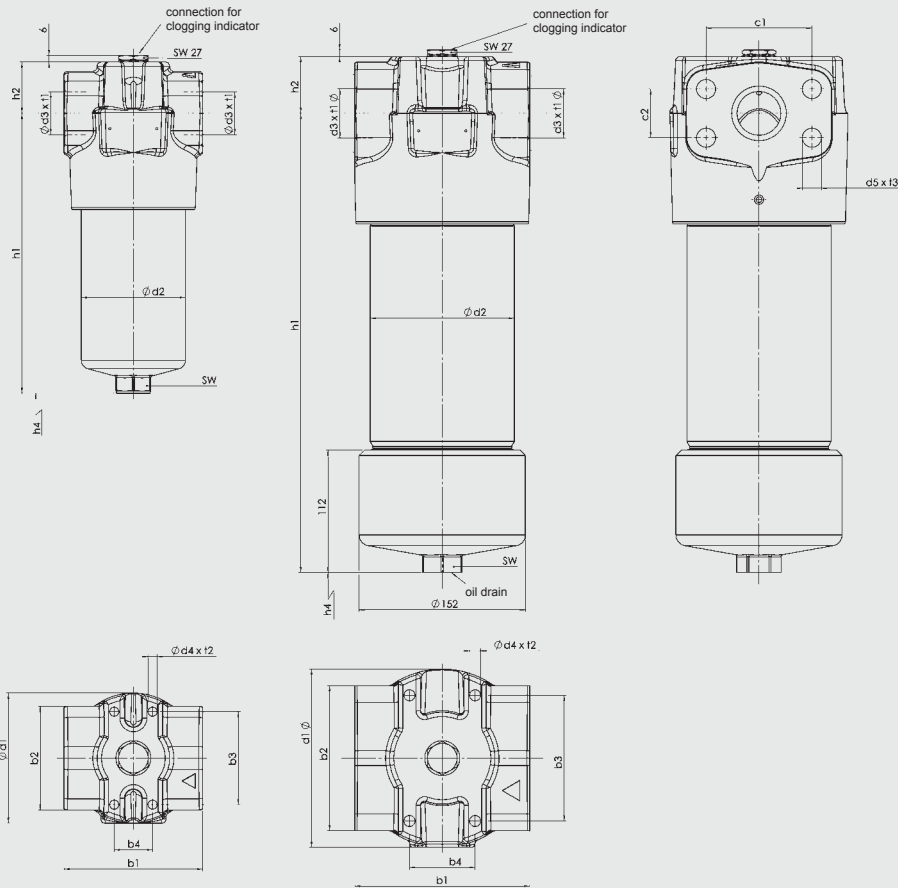

Type	b1	b2	b3	b4	c1	c2	d1	d2	d3	d4	d5	h1	h2	h4	SW	t1	t2	t3	Weight incl. element [kg]	Vol. of pressure chamber [l]
30... B...1.X	68	38	45	30	-	-	69	52	G 1/2	M5	-	131.5	38	75	24	14	6	-	2.3	0.13
60... C...1.X	90	71	56	32	-	-	86	68	G 3/4	M6	-	140	40	85	27	17	9	-	4.5	0.20
60... I...1.X	89	71	56	32	50.8	23.8	86	68	SAE DN 20	M6	M10	140	40	85	27	-	9	15	4.5	0.20
110... C...1.X	90	71	56	32	-	-	86	68	G 3/4	M6	-	209.5	40	85	27	17	9	-	5.4	0.33
110... I...1.X	89	71	56	32	50.8	23.8	86	68	SAE DN 20	M6	M10	209.5	40	85	27	-	9	15	5.4	0.33
140... C...1.X	89	71	56	32	-	-	86	68	G 3/4	M6	-	250.5	40	85	27	17	9	-	6.0	0.40
140... I...1.X	89	71	56	32	50.8	23.8	86	68	SAE DN 20	M6	M10	250.5	40	85	27	-	9	15	6.0	0.40
160... E...1.X	125	95	85	35	-	-	119	95	G1 1/4	M10	-	196.5	47	105	32	21	14	-	10.3	0.60
160... J...1.X	125	95	85	35	66.7	31.8	119	95	SAE DN 32	M10	M14	196.5	47	105	32	-	14	19	10.3	0.60
240... E...1.X	125	95	85	35	-	-	119	95	G1 1/4	M10	-	256	47	105	32	21	14	-	11.8	0.80
240... J...1.X	125	95	85	35	66.7	31.8	119	95	SAE DN 32	M10	M14	256	47	105	32	-	14	19	11.8	0.80
280... E...1.X	125	95	85	35	-	-	119	95	G1 1/4	M10	-	438	47	105	32	21	14	-	16.3	1.60
280... J...1.X	125	95	85	35	66.7	31.8	119	95	SAE DN 32	M10	M14	438	47	105	32	-	14	19	16.3	1.60
330... F...1.X	160	133	115	60	-	-	163	130	G1 1/2	M12	-	257.5	52	115	36	23	17	-	24.5	1.50
330... L...1.X	160	133	115	60	96.8	44.5	163	130	SAE DN 50	M12	M20	257.5	52	115	36	-	17	25	24.5	1.50
500... F...1.X	160	133	115	60	-	-	163	130	G1 1/2	M12	-	350.5	52	115	36	23	17	-	28.6	2.30
500... L...1.X	160	133	115	60	96.8	44.5	163	130	SAE DN 50	M12	M20	350.5	52	115	36	-	17	25	28.6	2.30
660... F...1.X	160	133	115	60	-	-	163	130	G1 1/2	M12	-	428	52	115	36	23	17	-	31.6	3.00
660... L...1.X	160	133	115	60	96.8	44.5	163	130	SAE DN 50	M12	M20	428	52	115	36	-	17	25	31.6	3.00
330... F...2.X	160	133	115	60	-	-	163	132	G1 1/2	M12	-	254	52	180	36	23	17	-	27.4	1.50
330... L...2.X	160	133	115	60	96.8	44.5	163	132	SAE DN 50	M12	M20	254	52	180	36	-	17	25	27.4	1.50
500... F...2.X	160	133	115	60	-	-	163	132	G1 1/2	M12	-	343	52	270	36	23	17	-	31.5	2.30
500... L...2.X	160	133	115	60	96.8	44.5	163	132	SAE DN 50	M12	M20	343	52	270	36	-	17	25	31.5	2.30
660... F...2.X	160	133	115	60	-	-	163	132	G1 1/2	M12	-	420	52	350	36	23	17	-	34.4	3.00
660... L...2.X	160	133	115	60	96.8	44.5	163	132	SAE DN 50	M12	M20	420	52	350	36	-	17	25	34.4	3.00
990... F...2.X	160	133	115	60	-	-	163	132	G1 1/2	M12	-	576	52	500	36	23	17	-	43.4	4.20
990... L...2.X	160	133	115	60	96.8	44.5	163	132	SAE DN 50	M12	M20	576	52	500	36	-	17	25	43.4	4.20
1320... F...2.X	160	133	115	60	-	-	163	132	G1 1/2	M12	-	742	52	670	36	23	17	-	51.1	5.60
1320... L...2.X	160	133	115	60	96.8	44.5	163	132	SAE DN 50	M12	M20	742	52	670	36	-	17	25	51.1	5.60
1500... G...2.X	196	134	110	54	-	-	176	152	G2	M12	-	822.5	60	700	36	30	22	-	69.3	8.20
1500... L...2.X	196	134	110	54	96.8	44.5	176	152	SAE DN 50	M12	M20	822.5	60	700	36	-	22	25	69.3	8.20

B, C, E, F, G = thread connection

I, J, L = flange connection to DIN ISO 6162, 6000 psi with metric thread

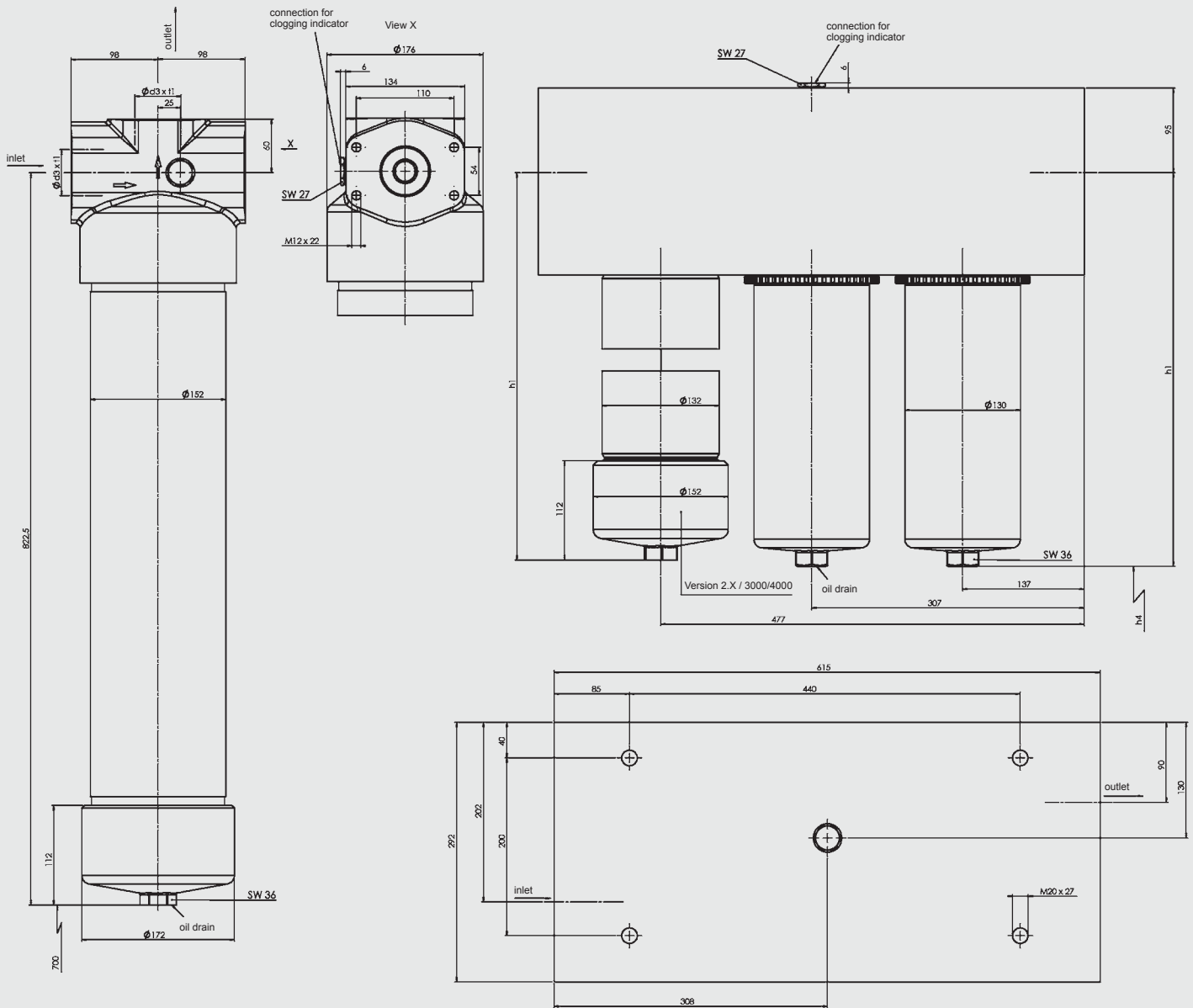

Type	d3	h1	h4	t1	Weight incl. element [kg]	Volume of pressure chamber [l]
1500 .. LG .. 2.X	G2	-	700	30	69.3	8.20
1500 .. LL .. 2.X	SAE DN 50	-	700	-	69.3	8.20
2000 .. N ... 1.X	SAE DN 80	447	95	-	265	14.00
2000 .. N ... 2.X	SAE DN 80	440	350	-	274	14.00
3000 .. N ... 2.X	SAE DN 80	596	500	-	302	17.60
4000 .. N ... 2.X	SAE DN 80	762	670	-	326	21.80

G = thread connection
 L, N = flange connection to DIN ISO 6162, 6000 psi with metric thread

DF 330 to 1320...3.X (element top-removable)

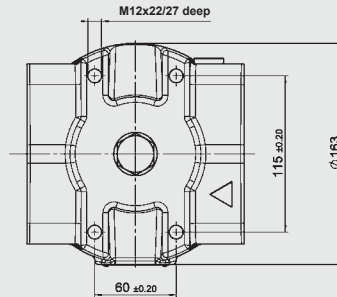
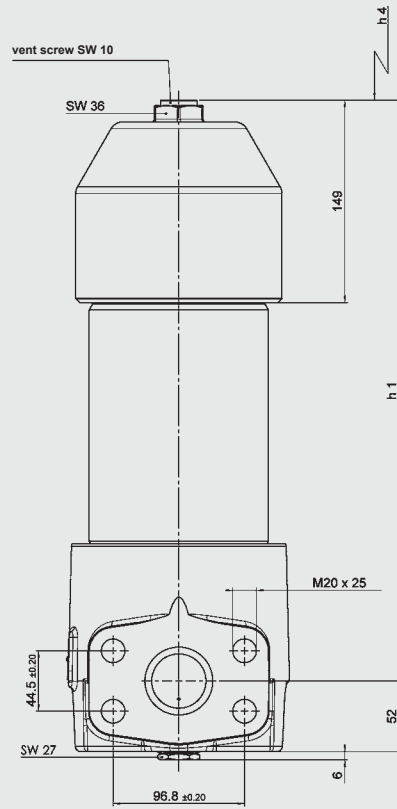
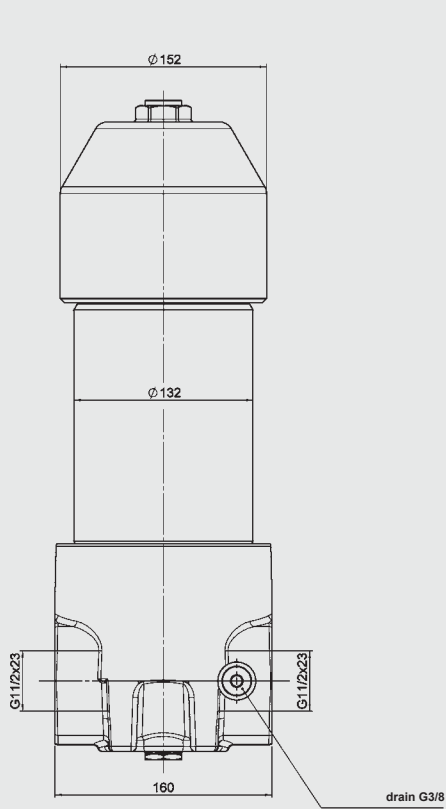

Type	h1	h4	Weight incl. element [kg]	Volume of pressure chamber [l]
330...F...3.X	263	80	27.9	1.50
330...L...3.X	263	80	27.9	1.50
500...F...3.X	351	170	31.8	2.30
500...L...3.X	351	170	31.8	2.30
660...F...3.X	428	250	33.9	3.00
660...L...3.X	428	250	33.9	3.00
990...F...3.X	583	400	43.1	4.20
990...L...3.X	583	400	43.1	4.20
1320...F...3.X	749	570	50.8	5.60
1320...L...3.X	749	570	50.8	5.60

F = thread connection

L = flange connection to DIN ISO 6162, 6000 psi with metric thread

DFFX 330 to 1320 (Δp -optimized; filter ports in L configuration)

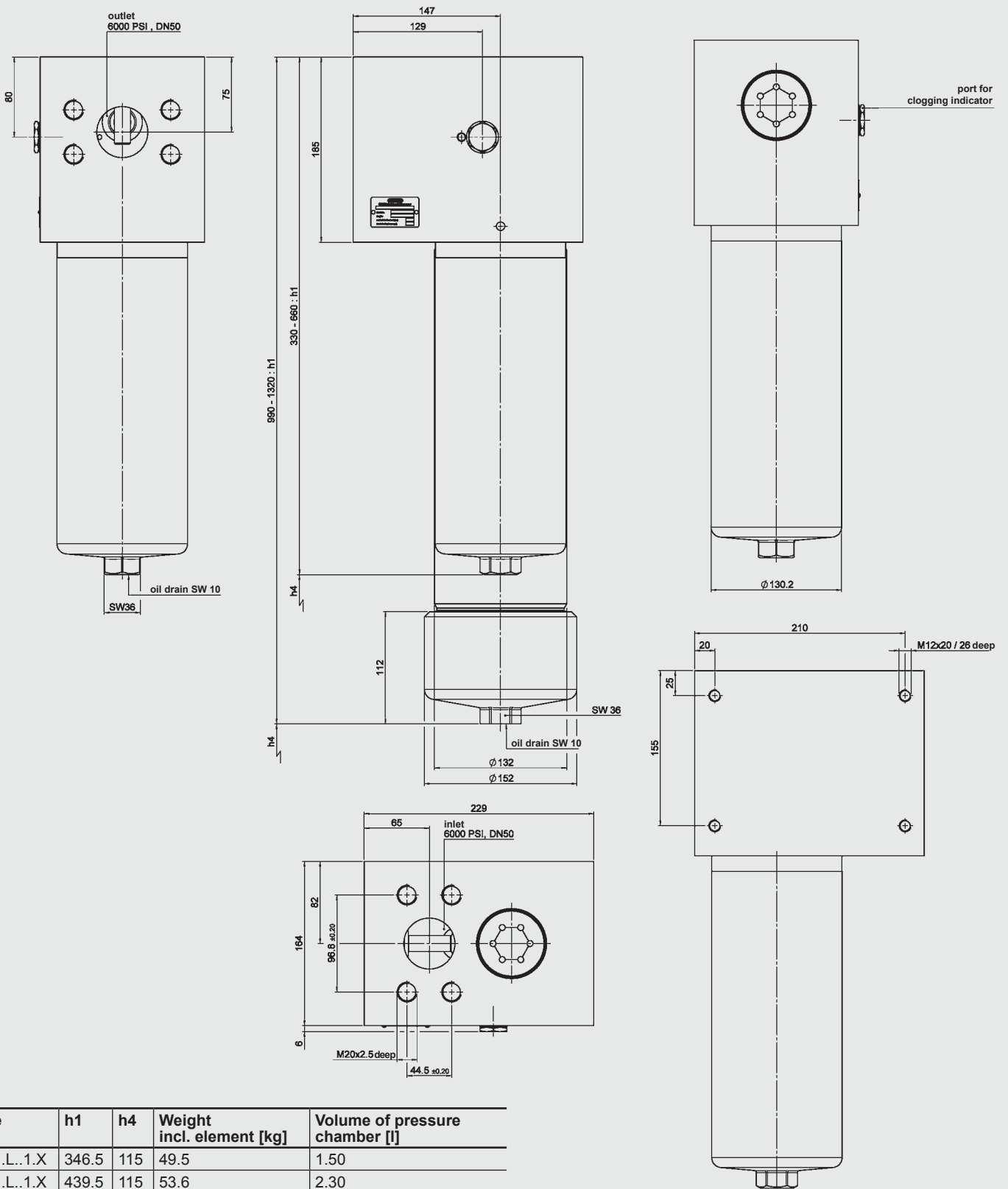

Type	h1	h4	Weight incl. element [kg]	Volume of pressure chamber [l]
330...L...1.X	346.5	115	49.5	1.50
500...L...1.X	439.5	115	53.6	2.30
660...L...1.X	517	115	56.6	3.00
990...L...2.X	665	500	68.4	4.20
1320...L...2.X	831	670	76.1	5.60

L = flange connection to DIN ISO 6162, 6000 psi with metric thread

NOTE

The information in this brochure relates to the operating conditions and applications described. For applications or operating conditions not described, please contact the relevant technical department. Subject to technical modifications.

HYDAC FILTERTECHNIK GMBH
 Industriegebiet
D-66280 Sulzbach/Saar
 Tel.: 0 68 97 / 509-01
 Fax: 0 68 97 / 509-300
 Internet: www.hydac.com
 E-Mail: filter@hydac.com