

VS 403 Ex i

Isolated switching amplifier

en 08-2017/02 50111301-03

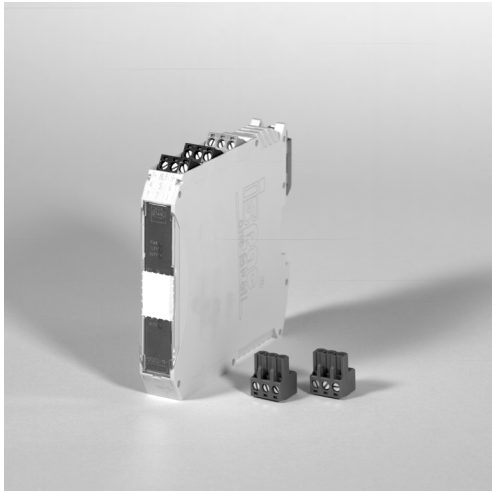

Dimensioned drawing

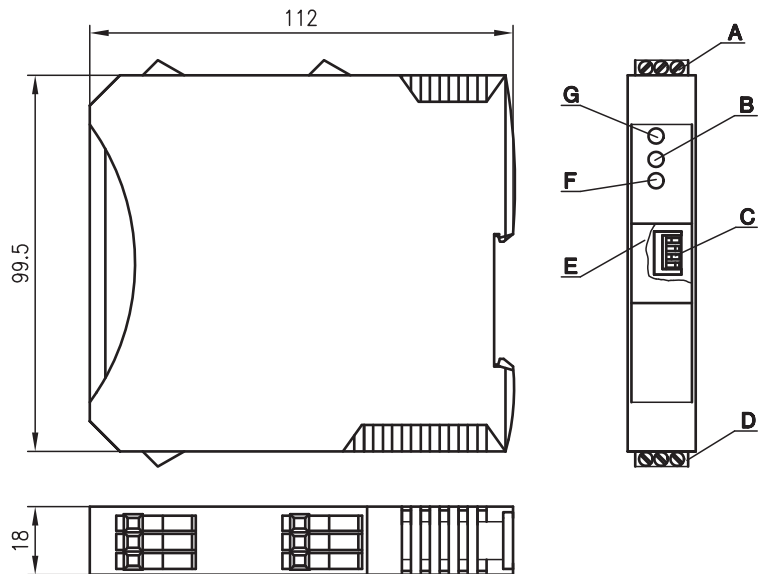

- A** Connection terminals: operating voltage and switching output
- B** Line Fault LF 1
- C** Switch for setting the operating modes
- D** Connection terminals: input [EEx ia] IIC
- E** Description field
- F** Switching state OUT 1
- G** Auxiliary energy available PWR

Electrical connection

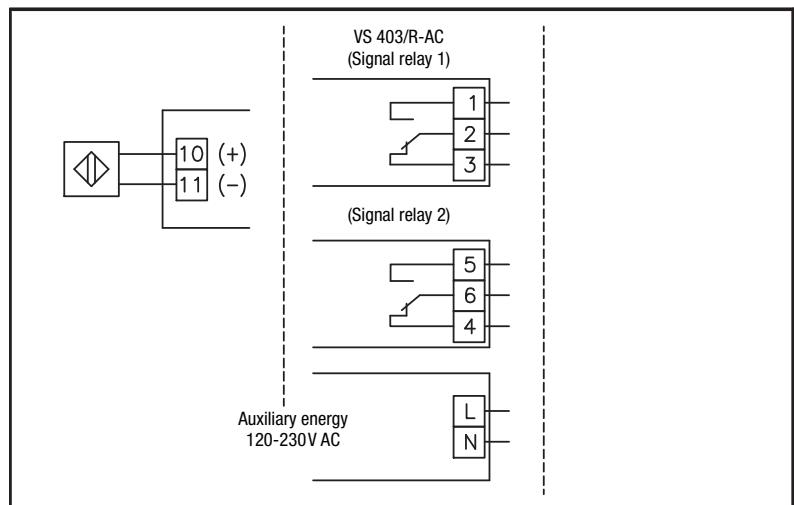

Adjustments

To change the operating mode, open the transparent front flap and make the desired setting on the DIP switch.

Switch in left position (OFF): function OFF

Switch in right position (ON): function ON

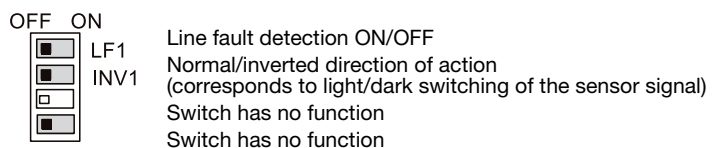

Normal direction of action -switch to left (OFF)- corresponds to figure for electrical connection. On delivery, both switches are in the OFF position (function off).



- Intrinsically safe input [ia Ga] IIC
- Input, output and operating voltage are galvanically isolated
- Wire break monitoring (may be deactivated)
- Operating modes adjustable
- Switching output with power relay
- 1 channel
- Top hat rail mounting
- Europe (ATEX): gas and dust
DMT 02 ATEX E 195 X
- Ex II (1) G [Ex ia Ga] IIC
- Ex II (1) D [Ex ia Da] IIIC
- Functional safety (IEC 61508)
Report: Exida STAHL 09/03-52 R019
max. SIL: 2



Accessories:

- Blue connection cable for intrinsically safe circuits (BK7 ... Ex)

We reserve the right to make changes • PAL_VS403RAC_EXI_en_50111301_03.fm

Specifications

Electrical data

Operating voltage	120 ... 230VAC
Frequency range	48 ... 62Hz
Power consumption	≤ 1.4VA

Ex i input

Acc. to IEC 60 947-5-6 (NAMUR)	
Current I_E for ON	≥ 2.1 mA
Current I_E for OFF	≤ 1.2 mA
Bias voltage	≤ 8.2V
Short-circuit current	≤ 8.2 mA
Internal resistance	1000Ω

Output

Minimum load	12V/100μA
Maximum load DC	250V/2A
Maximum load AC	250V/4A
Maximum switching power	50W/1000VA

Timing

Switching frequency (max.)	6Hz
Switching delay ON → OFF	≤ 10ms
Switching delay OFF → ON	≤ 10ms

Indicators

LED 1 green PWR	auxiliary energy available
LED 2 red LF 1	wire break
LED 3 yellow OUT 1	switching output ON

Mechanical data

Housing	plastic (polyamide 6.6)
Fire resistance housing	VO (UL standard 94)
Weight	160g
Mounting type	outside the potentially explosive area on DIN rails

Environmental data

Ambient temp. (operation/storage)	-20°C ... +70°C/-40°C ... +80°C
Protection class housing	IP 30
Protection class terminals	IP 20
Electromagnetic compatibility	IEC 60 947-5-6, NAMUR NE 21

Safety engineering data

Certification (ATEX)	Ex II (1) G [Ex ia Ga] IIC Ex II (1) D [Ex ia Da] IIIC
----------------------	---

Inputs (single channels)

Max. voltage U_0	9.6V
Max. current I_0	10mA
Max. power P_0	24mW
Max. connectable capacitance C_0	IIC 3.6μF
	IIB 26μF
	I 99μF
Max. connectable inductance L_0	IIC 350mH
	IIB 1000mH
	I 1000mH
Inner capacitance C_i	2.42nF
Inner inductance L_i	negligible
Maximum safe voltage	253V

Fault detection input

Wire break	$I_E < 0.05 \dots 0.35 \text{ mA}$
Short-circuit	$R_E < 100 \dots 360 \Omega$
Line fault display	Red LED
Line fault and auxiliary power failure message	NPN transistor, open collector, max. load 30V/100mA, switches to GND in the case of a fault (not available for VS 403/R-AC); pac-bus: potential-free contact

Tables

Diagrams

Remarks

Operate in accordance with intended use!

- ↪ The product may only be put into operation by competent persons.
- ↪ Only use the product in accordance with the intended use.

- When connecting sensor and isolated switching amplifier, make sure not to exceed the permissible limit values for intrinsic safety.
- Line fault and auxiliary power failure message. In the case of a fault, the auxiliary contact (30V/100mA) is switched to GND.

Order guide

Designation	Part no.
VS 403/R-AC	50040824