

**Features**

- 1-channel isolated barrier
- 24 V DC supply (bus powered)
- Dry contact or NAMUR input
- Usable as signal splitter (1 input and 2 outputs)
- 2 passive transistor outputs (resistive acc. to EN 60947-5-6)
- Line fault transparency (LFT)
- Up to SIL 2 acc. to IEC 61508

**Function**

This isolated barrier is used for intrinsic safety applications. The device transfers digital signals (NAMUR sensors or dry contacts) from a hazardous area to a safe area. The input controls two passive transistor outputs with a resistive output characteristic (acc. to EN60947-5-6). The outputs have three defined states: 1-Signal = 1.8 kΩ, 0-Signal = 14 kΩ and fault > 100 kΩ. This output characteristic offers line fault transparency on the signal lines. Switches allow to reverse the output mode of operation and to disable the line fault detection of the field circuit. This device mounts on a HiC Termination Board.

**Assembly**

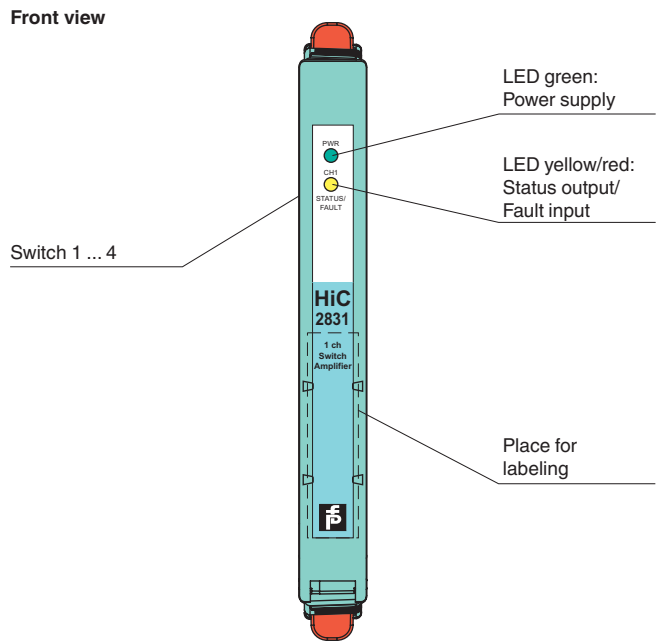

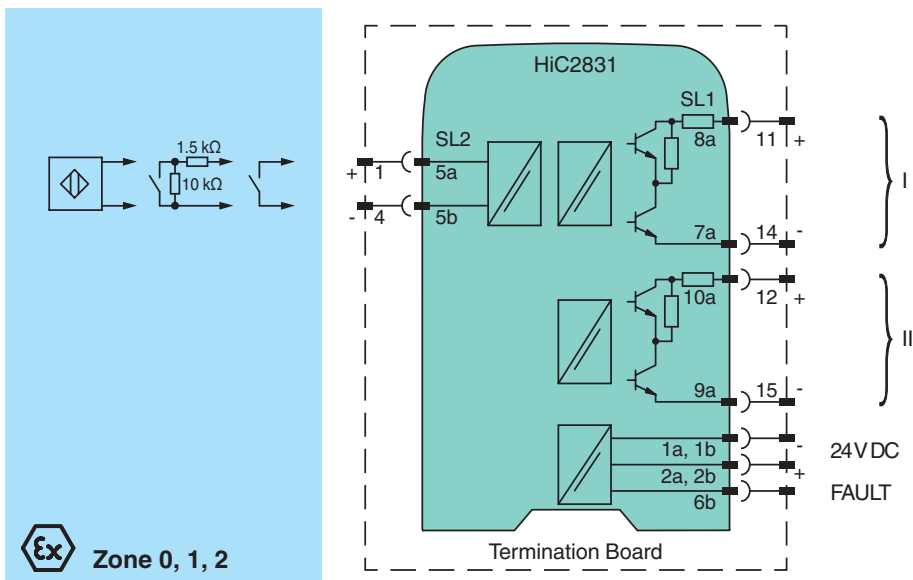

**Connection**



Release date 2016-09-12 11:40 Date of issue 2016-09-12 272022\_eng.xml

Refer to "General Notes Relating to Pepperl+Fuchs Product Information".

<b>General specifications</b>		
Signal type		Digital Input
<b>Supply</b>		
Connection		SL1: 1a(-), 1b(-); 2a(+), 2b(+)
Rated voltage	$U_n$	19 ... 30 V DC via Termination Board
Ripple		≤ 10 %
Rated current	$I_n$	≤ 25 mA
Power dissipation		≤ 500 mW
Power consumption		≤ 600 mW
<b>Input</b>		
Connection		SL2: 5a(+), 5b(-)
Rated values		acc. to EN 60947-5-6 (NAMUR), see system description for electrical data
Open circuit voltage/short-circuit current		approx. 10 V DC / approx. 8 mA
Switching point/switching hysteresis		1.2 ... 2.1 mA / approx. 0.2 mA
Line fault detection		breakage I ≤ 0.1 mA , short-circuit I ≥ 6.5 mA
Pulse/Pause ratio		≥ 100 μs / ≥ 100 μs
<b>Output</b>		
Connection		SL1: 8a(+), 7a(-); 10a(+), 9a(-)
Rated voltage	$U_n$	8 V DC
Response time		≤ 200 μs
Output I, II		signal or error message, passive transistor output (resistive) 0-signal: 14 kΩ ± 10 % 1-signal: 1.8 kΩ ± 10 % fault: > 100 kΩ
<b>Error message output</b>		
Connection		SL1: 6b
Output type		open collector transistor (internal fault bus)
<b>Transfer characteristics</b>		
Switching frequency		≤ 5 kHz
<b>Electrical isolation</b>		
Output/power supply		basic insulation according to IEC/EN 61010-1, rated insulation voltage 60 V <sub>eff</sub>
Output/Output		basic insulation according to IEC/EN 61010-1, rated insulation voltage 60 V <sub>eff</sub>
<b>Directive conformity</b>		
Electromagnetic compatibility		
Directive 2014/30/EU		EN 61326-1:2013 (industrial locations)
<b>Conformity</b>		
Electromagnetic compatibility		NE 21:2012 , EN 61326-3-2:2008
Degree of protection		IEC 60529:2001
Protection against electrical shock		IEC 61010-1
<b>Ambient conditions</b>		
Ambient temperature		-20 ... 60 °C (-4 ... 140 °F)
<b>Mechanical specifications</b>		
Degree of protection		IP20
Mass		approx. 100 g
Dimensions		12.5 x 128 x 106 mm (0.5 x 5.1 x 4.2 inch)
Mounting		on Termination Board
Coding		pin 1 and 2 trimmed For further information see system description.
<b>Data for application in connection with hazardous areas</b>		
EC-Type Examination Certificate		BVS 11 ATEX E 026
Group, category, type of protection		 II (1) G [Ex ia] IIC, II (1) D [Ex ia] IIIC  I (M1) [Ex ia] I
Input		Ex ia
Voltage	$U_o$	10.5 V
Current	$I_o$	17.1 mA
Power	$P_o$	45 mW (linear characteristic)
Supply		
Maximum safe voltage	$U_m$	253 V AC (Attention! $U_m$ is no rated voltage.)
Output		
Maximum safe voltage	$U_m$	253 V AC (Attention! $U_m$ is no rated voltage.)
Statement of conformity		KIWA 15 ATEX 0037 X
Group, category, type of protection, temperature class		 II 3G Ex nA IIC T4 Gc
Electrical isolation		
Input/Output		safe electrical isolation acc. to IEC/EN 60079-11, voltage peak value 375 V

Release date 2016-09-12 11:40 Date of issue 2016-09-12 272022\_eng.xml

Refer to "General Notes Relating to Pepperl+Fuchs Product Information".

Pepperl+Fuchs Group  
www.pepperl-fuchs.com

USA: +1 330 486 0002  
pa-info@us.pepperl-fuchs.com

Germany: +49 621 776 2222  
pa-info@de.pepperl-fuchs.com

Singapore: +65 6779 9091  
pa-info@sg.pepperl-fuchs.com

Input/power supply	safe electrical isolation acc. to IEC/EN 60079-11, voltage peak value 375 V
Directive conformity	
Directive 2014/34/EU	EN 60079-0:2012+A11:2013 , EN 60079-11:2012 , EN 60079-15:2010 , EN 50303:2000
<b>International approvals</b>	
UL approval	
Control drawing	116-0331
IECEX approval	IECEX BVS 11.0040
Approved for	[Ex ia Ga] IIC, [Ex ia] IIIC , [Ex ia] I
<b>General information</b>	
Supplementary information	EC-Type Examination Certificate, Statement of Conformity, Declaration of Conformity, Attestation of Conformity and instructions have to be observed where applicable. For information see www.pepperl-fuchs.com.

## Configuration

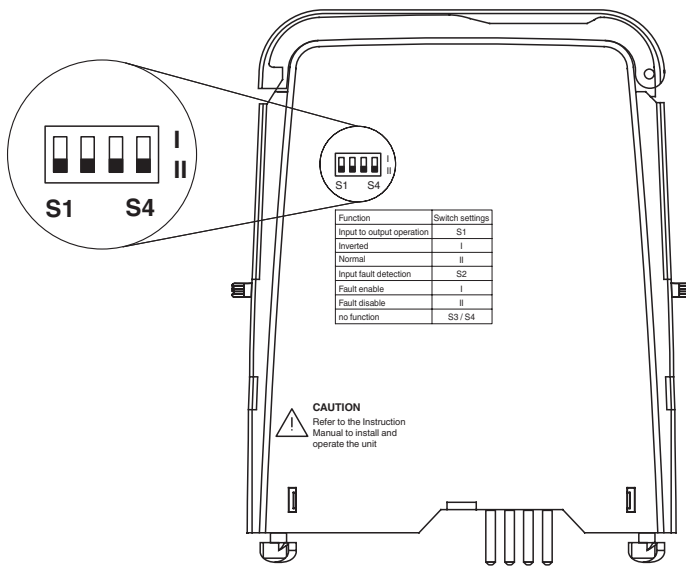

### Switch settings

S	Function		Position
1	Mode of operation	Inverted	I
		Normal	II
2	Input line fault detection	ON	I
		OFF	II
3	no function		
4	no function		

Configure the device in the following way:

- Push the red Quick Lok Bars on each side of the device in the upper position.
- Remove the device from Termination Board.
- Set the DIP switches according to the figure.



*The pins for this device are trimmed to polarize it according to its safety parameter. Do not change! For further information see system description.*

**Trip points**

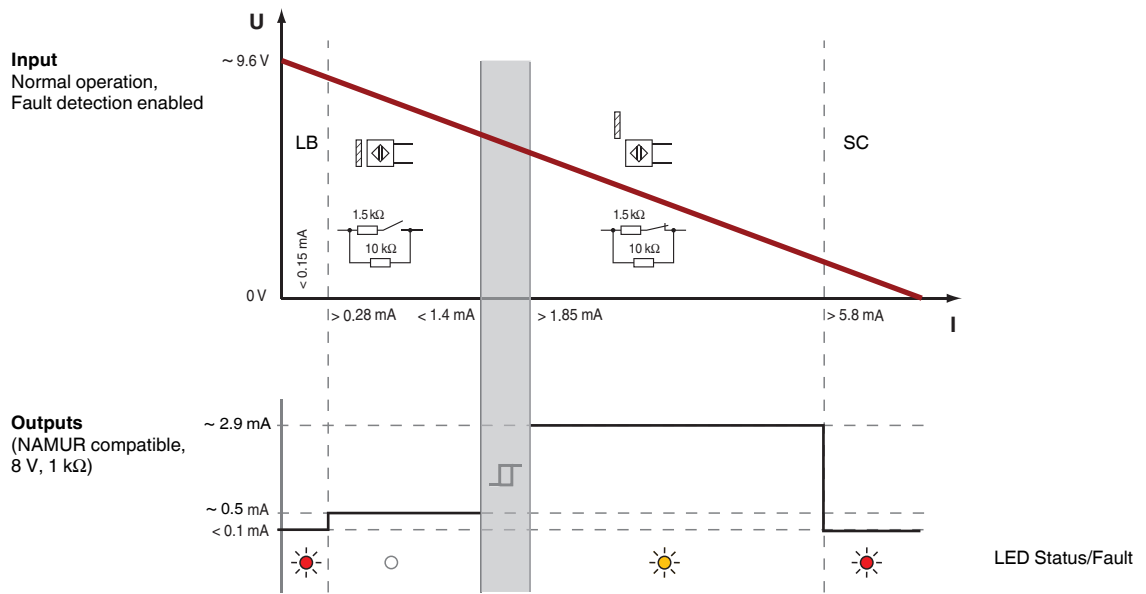

Release date 2016-09-12 11:40 Date of issue 2016-09-12 272022\_eng.xml

Refer to "General Notes Relating to Pepperl+Fuchs Product Information".

Pepperl+Fuchs Group  
www.pepperl-fuchs.com

USA: +1 330 486 0002  
pa-info@us.pepperl-fuchs.com

Germany: +49 621 776 2222  
pa-info@de.pepperl-fuchs.com

Singapore: +65 6779 9091  
pa-info@sg.pepperl-fuchs.com