

E43212

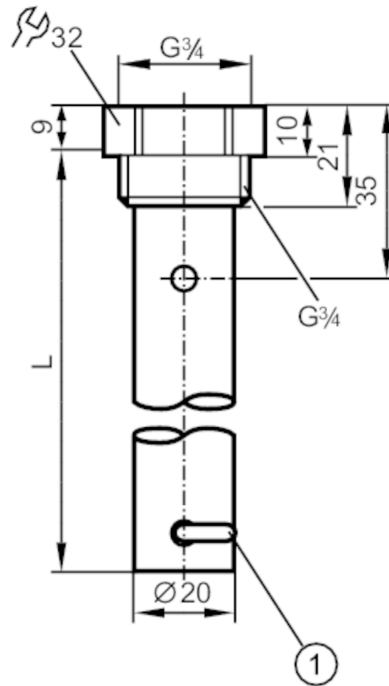

Coaxial pipe for level sensors

LR COAX TUBE G3/4 L450



1 fixing bracket for centring piece

CRN

Application	
Design	for level sensors LR
Medium temperature [°C]	-40...200
Tank pressure [bar]	-1...16
MAWP (for applications according to CRN) [bar]	16
Mechanical data	
Weight [g]	290.5
Materials	stainless steel (1.4301 / 304); Sealing: Tesnit; Centring piece: PPS glass fibre reinforced; fixing bracket: stainless steel (1.4310 / 301)
Sensor connection	G 3/4
Process connection	G 3/4
Length [mm]	450
Accessories	
Accessories (supplied)	sealings: 1, Tesnit
Remarks	
Pack quantity	1 pcs.