

Industrial Potentiometer



FEATURES

- High power rating 2 W at 70 °C
- Full sealing
- Low contact resistance variation (1 % typical)
- Robust nickel plated brass shaft
- Use of faston 2.86 connections
- Cermet element
- Center detent option
- Test according to CECC 41000 or IEC 60393-1
- Electrical performance in accordance with MIL-PRF-94 standards
- Material categorization: for definitions of compliance please see www.vishay.com/doc?99912



RoHS
COMPLIANT

DIMENSIONS in millimeters (inches) ± 0.5 mm (± 0.02")

PRV4F

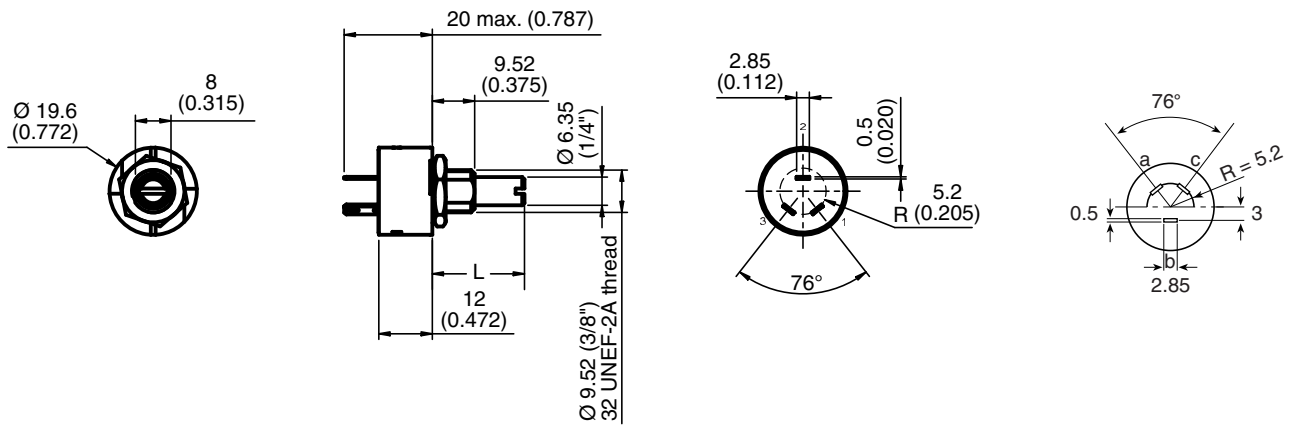

Length L	1/2"	7/8"	2"
Shaft code	gbs	gjs	grs

ELECTRICAL SPECIFICATIONS		
Resistive element		Cermet
Electrical travel		$270^\circ \pm 10^\circ$
Resistance range	Linear taper	20 Ω to 10 M Ω
	Logarithmic taper	100 Ω to 2.5 M Ω
Standard series		1 - 2 - 2.5 - 5
Tolerance	Standard	$\pm 20\%$
	On request	$\pm 10\%$
Taper		
Circuit diagram		
Power rating	Linear logarithmic	2 W at 70 $^\circ\text{C}$ 1 W at 70 $^\circ\text{C}$
Temperature coefficient (typical)		300 ppm/ $^\circ\text{C}$
Limiting element voltage (linear law)		500 V
Contact resistance variation (typical)		1 % Rn or 3 Ω
End resistance		4 Ω
Dielectric strength (RMS)		1500 V
Insulation resistance (500 V _{DC})		10 ⁴ M Ω
Independent linearity (typical)		5 %

STANDARD RESISTANCE ELEMENT DATA						
STANDARD RESISTANCE VALUES	LINEAR TAPER			LOG. TAPER		
	MAX. POWER AT 70 °C	MAX. WORKING VOLTAGE	MAX. CUR. THROUGH ELEMENT WIPER	MAX. POWER AT 70 °C	MAX. WORKING VOLTAGE	MAX. CUR. THROUGH ELEMENT WIPER
Ω	W	V	mA	W	V	mA
20	2	6.32	316			
25	2	7.07	283			
50	2	10.0	200			
100	2	14.1	141	1	10.0	100
200	2	20.0	100.0	1	14.1	70.7
250	2	22.4	89.4	1	15.8	53.2
500	2	31.6	53.2	1	22.4	44.7
1K	2	44.7	44.7	1	31.5	31.6
2K	2	53.2	31.6	1	44.7	22.4
2.5K	2	70.7	28.3	1	50.0	20.0
5K	2	100	20.00	1	70.7	14.1
10K	2	141	14.14	1	100	10.0
20K	2	200	10.00	1	141	7.07
25K	2	224	6.04	1	158	6.32
50K	2	315	6.32	1	224	4.47
100K	2	447	4.47	1	315	3.16
200K	1	500	2.50	1	447	2.24
250K	1	500	2.00	1	499	2.00
500K	0.50	500	1.00	0.50	500	1.00
1M	0.25	500	0.50	0.25	500	0.50
2M	0.13	500	0.25	0.13	500	0.25
2.5M	0.10	500	0.20	0.10	500	0.20
5M	0.05	500				
10M	0.03	500				

MECHANICAL SPECIFICATIONS	
Mechanical travel	300° ± 5°
Operating torque (typical)	3 Ncm max. (4.3 oz.-inch max.)
End stop torque	70 Ncm max. (6 lb-inch max.)
Tightening torque of mounting nut	200 Ncm max. (17.3 lb-inch max.)
Unit weight	23 g to 32 g max. (0.82 oz. to 1.14 oz.)

ENVIRONMENTAL SPECIFICATIONS	
Temperature range	-55 °C to +125 °C
Climatic category	55/125/10
Sealing	Fully sealed - Container IP67

OPTIONS	
Special feature command shaft	Length is measured from the mounting surface to the free end of the shaft. The screwdriver slot is aligned with the wiper within ± 10°. Special shafts are available, in accordance to drawings supplied by customers. We recommend that customers should not machine tool shafts, in order to avoid damage. Bending or torsion of terminals should also be avoided.
PRV4 LPRP - with locating peg	



MARKING	
<ul style="list-style-type: none"> • Vishay trademark • Part number (including ohmic value code, tolerance code, and taper) • Manufacturing date • Marking of terminals 1, 2, 3 	

PERFORMANCE				
TESTS	CONDITIONS	TYPICAL VALUES AND DRIFTS		
		$\Delta R_T/R_T$ (%)	$\Delta R_{1-2}/R_{1-2}$ (%)	OTHER
Electrical endurance	1000 h at rated power 90°/30° - ambient temp. 70 °C	± 3 %	± 5 %	Contact res. variation: < 5 %
Moisture resistance	MIL-STD-202 method 105 10 cycles of 24 h constituted with damp heat - cold - vibrations	± 2 %	± 3 %	Dielectric strength: 100 V _{RMS} Insulation resistance: > 10 ⁴ MΩ
Damp heat, steady state	10 days 40 °C, 93 % HR	± 2 %	± 3 %	Dielectric strength: 100 V _{RMS} Insulation resistance: > 10 ⁴ MΩ
Change of temperature	5 cycles -55 °C at +125 °C	± 1 %	-	$\Delta V_{1-2}/V_{1-3} < \pm 2 \%$
Mechanical endurance	25 000 cycles	± 5 %	-	-
Shock	MIL-STD-202 method 213/1 100 g's at 6 ms 3 successive shocks in 3 directions	± 1 %	-	$\Delta V_{1-2}/V_{1-3} < \pm 1 \%$
Vibration	MIL-STD-202 method 204/D 20 g's at 12 h	± 1 %	-	$\Delta V_{1-2}/V_{1-3} < \pm 1 \%$

Note

- Nothing stated herein shall be construed as a guarantee of quality or durability.

ORDERING INFORMATION (part number)																	
P	R	V	4	F	L	G	J	S	1	0	2	M	L				
MODEL	BUSHING	OPTION		SHAFT		SHAFT END		OHMIC VALUE		TOLERANCE		TAPER		SPECIAL			
PRV4	F = Ø 3/8"	L = LPRP 0 = no option		GB GJ GR AP		S = slotted R = round F = flatted D = custom		Linear from 20 Ω to 10 MΩ Logarithmic from 100 Ω to 2.5. MΩ 102 = 1 kΩ		M = 20 % On request: K = 10 %		A = linear L = clockwise logarithmic F = inverse clockwise logarithmic		CV1M = detent option or special code given by Vishay			

PART NUMBER DESCRIPTION (for information only)												
PRV4	F	L	GJ	S	1K	20 %	L		BO50			e3
MODEL	BUSHING	OPTION	SHAFT	SHAFT END	VALUE	TOLERANCE	TAPER	DETENT OPTION	PACKAGING	AP N°	SPECIAL	LEAD (Pb)-FREE

RELATED DOCUMENTS	
APPLICATION NOTES	
Potentiometers and Trimmers	www.vishay.com/doc?51001
Guidelines for Vishay Sfernice Resistive and Inductive Components	www.vishay.com/doc?52029



Disclaimer

ALL PRODUCT, PRODUCT SPECIFICATIONS AND DATA ARE SUBJECT TO CHANGE WITHOUT NOTICE TO IMPROVE RELIABILITY, FUNCTION OR DESIGN OR OTHERWISE.

Vishay Intertechnology, Inc., its affiliates, agents, and employees, and all persons acting on its or their behalf (collectively, "Vishay"), disclaim any and all liability for any errors, inaccuracies or incompleteness contained in any datasheet or in any other disclosure relating to any product.

Vishay makes no warranty, representation or guarantee regarding the suitability of the products for any particular purpose or the continuing production of any product. To the maximum extent permitted by applicable law, Vishay disclaims (i) any and all liability arising out of the application or use of any product, (ii) any and all liability, including without limitation special, consequential or incidental damages, and (iii) any and all implied warranties, including warranties of fitness for particular purpose, non-infringement and merchantability.

Statements regarding the suitability of products for certain types of applications are based on Vishay's knowledge of typical requirements that are often placed on Vishay products in generic applications. Such statements are not binding statements about the suitability of products for a particular application. It is the customer's responsibility to validate that a particular product with the properties described in the product specification is suitable for use in a particular application. Parameters provided in datasheets and/or specifications may vary in different applications and performance may vary over time. All operating parameters, including typical parameters, must be validated for each customer application by the customer's technical experts. Product specifications do not expand or otherwise modify Vishay's terms and conditions of purchase, including but not limited to the warranty expressed therein.

Except as expressly indicated in writing, Vishay products are not designed for use in medical, life-saving, or life-sustaining applications or for any other application in which the failure of the Vishay product could result in personal injury or death. Customers using or selling Vishay products not expressly indicated for use in such applications do so at their own risk. Please contact authorized Vishay personnel to obtain written terms and conditions regarding products designed for such applications.

No license, express or implied, by estoppel or otherwise, to any intellectual property rights is granted by this document or by any conduct of Vishay. Product names and markings noted herein may be trademarks of their respective owners.

Material Category Policy

Vishay Intertechnology, Inc. hereby certifies that all its products that are identified as RoHS-Compliant fulfill the definitions and restrictions defined under Directive 2011/65/EU of The European Parliament and of the Council of June 8, 2011 on the restriction of the use of certain hazardous substances in electrical and electronic equipment (EEE) - recast, unless otherwise specified as non-compliant.

Please note that some Vishay documentation may still make reference to RoHS Directive 2002/95/EC. We confirm that all the products identified as being compliant to Directive 2002/95/EC conform to Directive 2011/65/EU.

Vishay Intertechnology, Inc. hereby certifies that all its products that are identified as Halogen-Free follow Halogen-Free requirements as per JEDEC JS709A standards. Please note that some Vishay documentation may still make reference to the IEC 61249-2-21 definition. We confirm that all the products identified as being compliant to IEC 61249-2-21 conform to JEDEC JS709A standards.