

5 kW two-channel interleaved CCM PFC EVAL board

IKW40N65WR5, IDW60C65D1 and 1ED44175 in high frequency PFC application

About this document

Scope and purpose

This user manual provides an overview of the reference design developed for the EVAL-PFC5KIKWWR5SYS board, including its main features, key data, and mechanical dimensions.

EVAL-PFC5KIKWWR5SYS is a fast switching, analog-controlled two-channel interleaved 5 KW PFC converter with Infineon's TRENCHSTOP™ 5 WR5 IGBT IKW40N65WR5. It is designed to show case the use of WR5 IGBT with high switching frequencies up to 60 kHz in an interleaved PFC application, which enables many system benefits such as smaller size PFC choke, overall system size and BOM cost. This document also demonstrates a very effective example of design with Infineon's low side gate driver 1ED44175 and rapid1 power silicon diode IDW60C65D1.

The evaluation board has a flexible input AC voltage between 180-264 V, and provides a 400 V output voltage with maximum current up to 12.5 A. This document provides suggestions on how to develop interleaved PFC converters in similar power ranges adapted to specific requirements, such as high-power SMPS, floor-standing air conditioners in major home appliances.

Intended audience

This user guide is intended for all technical specialists who are familiar with high-speed AC-DC power stage design and high-power interleaved PFC converters. The reference design is intended to be used under laboratory conditions and only by trained specialists.

Evaluation Board

This board will be used during design in, for evaluation and measurement of characteristics, and proof of data sheet specifications.

Note: PCB and auxiliary circuits are NOT optimized for final customer design.

Note: Boards do not necessarily meet safety, EMI, quality standards (for example UL, CE) requirements.

Important notice

Important notice

“Evaluation Boards and Reference Boards” shall mean products embedded on a printed circuit board (PCB) for demonstration and/or evaluation purposes, which include, without limitation, demonstration, reference and evaluation boards, kits and design (collectively referred to as “Reference Board”).

Environmental conditions have been considered in the design of the Evaluation Boards and Reference Boards provided by Infineon Technologies. The design of the Evaluation Boards and Reference Boards has been tested by Infineon Technologies only as described in this document. The design is not qualified in terms of safety requirements, manufacturing and operation over the entire operating temperature range or lifetime.

The Evaluation Boards and Reference Boards provided by Infineon Technologies are subject to functional testing only under typical load conditions. Evaluation Boards and Reference Boards are not subject to the same procedures as regular products regarding returned material analysis (RMA), process change notification (PCN) and product discontinuation (PD).

Evaluation Boards and Reference Boards are not commercialized products, and are solely intended for evaluation and testing purposes. In particular, they shall not be used for reliability testing or production. The Evaluation Boards and Reference Boards may therefore not comply with CE or similar standards (including but not limited to the EMC Directive 2004/EC/108 and the EMC Act) and may not fulfill other requirements of the country in which they are operated by the customer. The customer shall ensure that all Evaluation Boards and Reference Boards will be handled in a way which is compliant with the relevant requirements and standards of the country in which they are operated.

The Evaluation Boards and Reference Boards as well as the information provided in this document are addressed only to qualified and skilled technical staff, for laboratory usage, and shall be used and managed according to the terms and conditions set forth in this document and in other related documentation supplied with the respective Evaluation Board or Reference Board.

It is the responsibility of the customer’s technical departments to evaluate the suitability of the Evaluation Boards and Reference Boards for the intended application, and to evaluate the completeness and correctness of the information provided in this document with respect to such application.

The customer is obliged to ensure that the use of the Evaluation Boards and Reference Boards does not cause any harm to persons or third party property.

The Evaluation Boards and Reference Boards and any information in this document is provided "as is" and Infineon Technologies disclaims any warranties, express or implied, including but not limited to warranties of non-infringement of third party rights and implied warranties of fitness for any purpose, or for merchantability.

Infineon Technologies shall not be responsible for any damages resulting from the use of the Evaluation Boards and Reference Boards and/or from any information provided in this document. The customer is obliged to defend, indemnify and hold Infineon Technologies harmless from and against any claims or damages arising out of or resulting from any use thereof.

Infineon Technologies reserves the right to modify this document and/or any information provided herein at any time without further notice.

Safety precautions

Safety precautions

Note: Please note the following warnings regarding the hazards associated with development systems.

Table 1 Safety precautions

	<p>Warning: The DC link potential of this board is up to 400 VDC. When measuring voltage waveforms by oscilloscope, high voltage differential probes must be used. Failure to do so may result in personal injury or death.</p>
	<p>Warning: The evaluation board contains DC bus capacitors which take time to discharge after removal of the main supply. Before working on the drive system, wait five minutes for capacitors to discharge to safe voltage levels. Failure to do so may result in personal injury or death.</p>
	<p>Warning: The evaluation board is connected to the grid input during testing. Hence, high-voltage differential probes must be used when measuring voltage waveforms by oscilloscope. Failure to do so may result in personal injury or death.</p>
	<p>Caution: The heat sink and device surfaces of the evaluation or reference board may become hot during testing. Hence, necessary precautions are required while handling the board. Failure to comply may cause injury.</p>
	<p>Caution: Only personnel familiar with the drive, power electronics and associated machinery should plan, install, commission and subsequently service the system. Failure to comply may result in personal injury and/or equipment damage.</p>
	<p>Caution: The evaluation board contains parts and assemblies sensitive to electrostatic discharge (ESD). Electrostatic control precautions are required when installing, testing, servicing or repairing the assembly. Component damage may result if ESD control procedures are not followed. If you are not familiar with electrostatic control procedures, refer to the applicable ESD protection handbooks and guidelines.</p>
	<p>Caution: A drive that is incorrectly applied or installed can lead to component damage or reduction in product lifetime. Wiring or application errors such as undersizing the motor, supplying an incorrect or inadequate AC supply, or excessive ambient temperatures may result in system malfunction.</p>
	<p>Caution: The evaluation or reference board is shipped with packing materials that need to be removed prior to installation. Failure to remove all packing materials that are unnecessary for system installation may result in overheating or abnormal operating conditions.</p>

Table of contents

About this document	1
Important notice	2
Safety precautions	3
Table of contents	4
1 The board at a glance	5
1.1 Interleaved PFC	5
1.2 Block diagram of the EVAL-PFC5KIKWWR5SYS	6
2 System and functional description	8
2.1 General overview.....	8
2.1.1 UCC28070 - analogy controller	9
2.1.2 IKW40N65WR5 - fast switching WR5 IGBT	9
2.1.3 IDW60C65D1 – rapid1 power silicon diode.....	9
2.1.4 1ED44175 - low side gate driver.....	10
2.2 Board specifications.....	10
3 System design	11
3.1 Schematics	11
3.2 Layout	17
3.3 Bill of material	20
3.4 Connector details	24
4 System performance	25
4.1 Efficiency and PFC measurements	25
4.2 Start-up behavior	26
4.3 Input current and inductor current cancellation	27
4.4 Switching performance of IGBT at steady state.....	30
4.5 Output ripple voltage	31
4.6 Input voltage and input current.....	33
4.7 Load step tests	34
4.8 Thermal measurements.....	36
5 Conclusions	38
6 References and appendices	39
6.1 Abbreviations and definitions.....	39
6.2 References	39
6.3 Additional information.....	39
Revision history	40

The board at a glance

1 The board at a glance

This section of the UG-2021-06 describes the basic concepts about interleaved PFC and a brief introduction about the design of EVAL-PFC5KIKWWR5SYS board.

1.1 Interleaved PFC

The standard boost converter is the most popular topology for power factor correction due to a simple control of the input current while keeping the output voltage constant. For medium power levels, increasing the output power and improving overall efficiency leads to the use of several converters in a parallel connection, such as two channels or three channels connected in parallel. Furthermore, if the switches operate at two-channel connection with 180° out of phase or three-channel connection with 120° out of phase, the interleaved operation shares the same load capacitors and reduces input current ripple significantly. It also eases the burden of filtering conducted EMI noise and helps reduce the EMI filter and CIN sizes.

This approach has several other benefits, such as ease of implementation, the use of more, but smaller components and better heat distribution. Simultaneously, the output capacitor current ripple is also decreased and evenly distributed in each channel, which can extend the life of the capacitors, help to reduce its size and cost. Compared to a single boost converter, the inductors in interleaved PFC handle only half or one-third of the current, inductors with much lower inductance values can reach the same high power, and lower inductance means smaller inductors and higher power density for a given power rating.

Figure 1 is an example of two-channel interleaved PFC. Its detailed operation principles and key waveforms are shown in Figure 2.

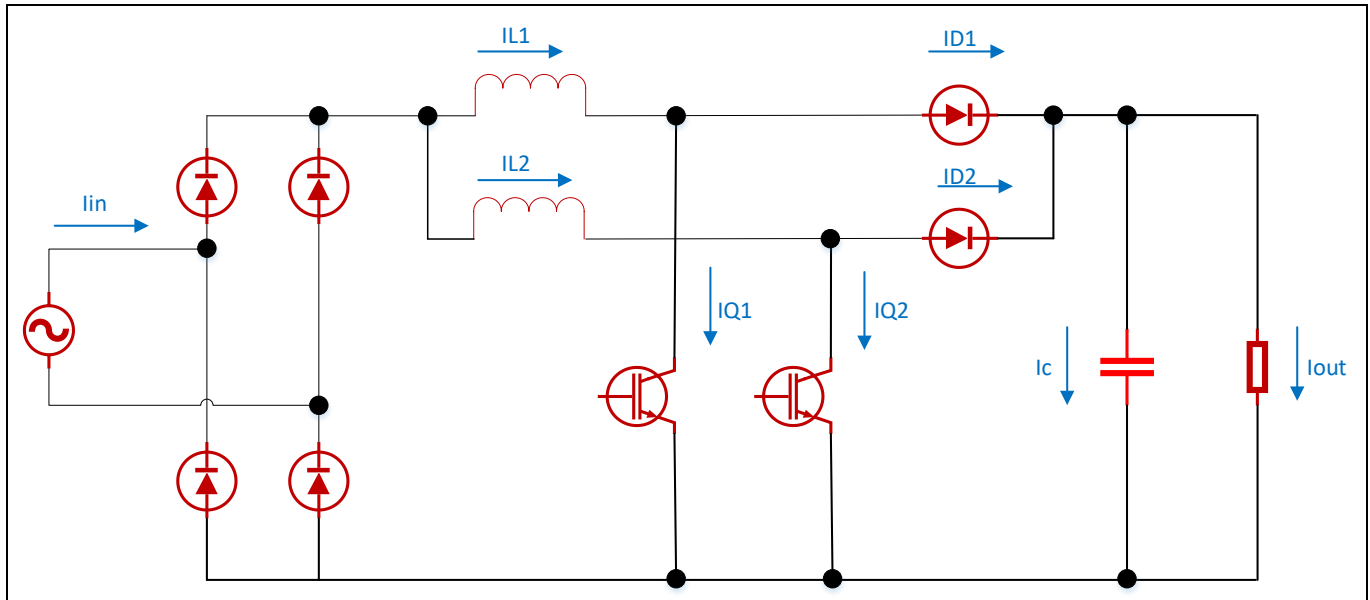

Figure 1 Block diagram of two-channel interleaved PFC

The board at a glance

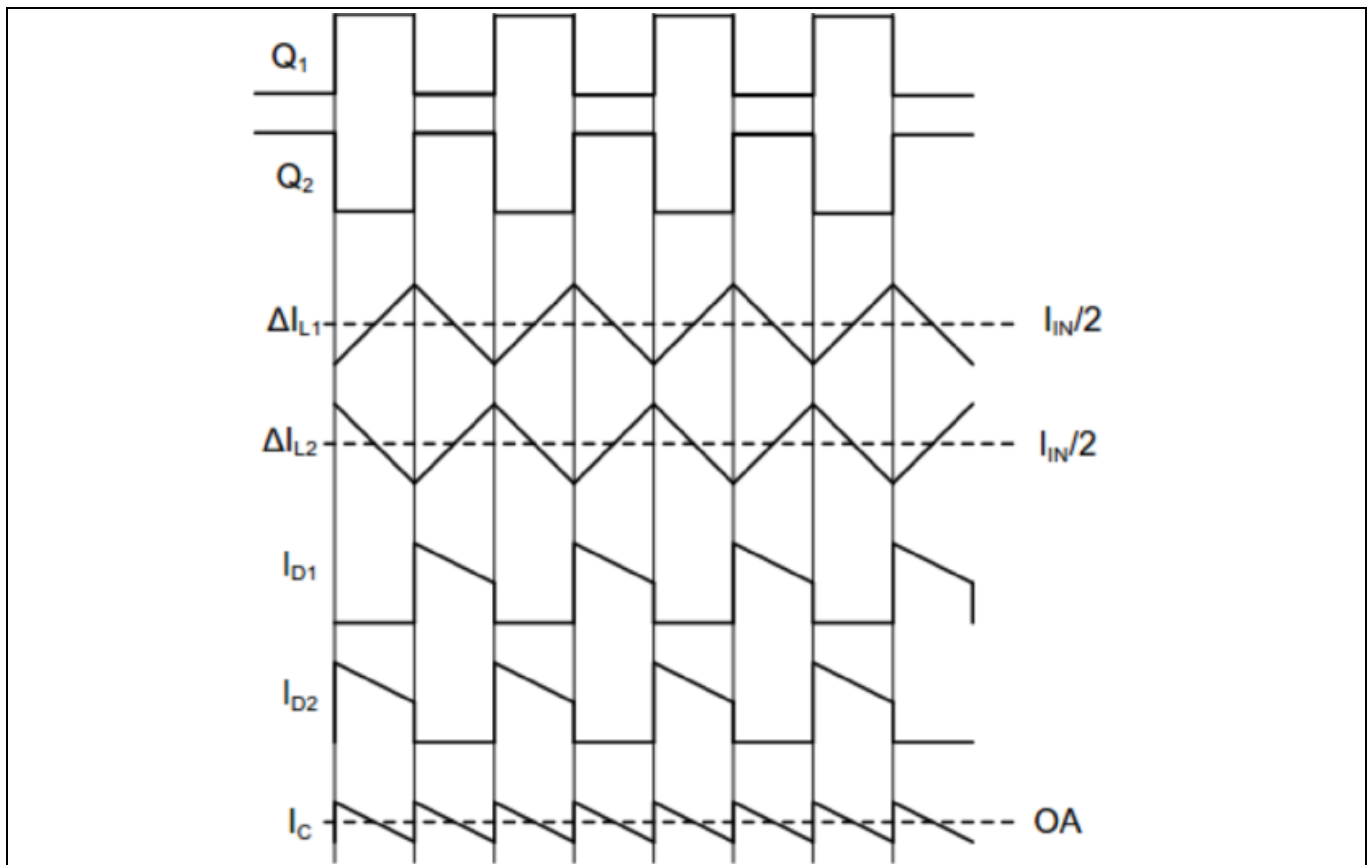

Figure 2 Principles of operation for the two-channel interleaved PFC

1.2 Block diagram of the EVAL-PFC5KIKWWR5SYS

As we know, reduction the size of power converters by increasing switching frequency and reducing magnetic component size is a goal that has been pursued for decades. This is especially true when using IGBTs in a switching mode power supply. Higher switching frequency, means smaller size and lower cost. A high performance IGBT is the key component in helping customers to gain a bigger market share. Fortunately, Infineon's WR5 IGBT is specifically optimized for full-rated hard-switching applications with an excellent price/performance ratio, and is recommended for use in AC-DC PFC stage for cost-sensitive applications. The EVAL-PFC5KIKWWR5SYS is an evaluation board for demonstrating the switching performance of TRENCHSTOP™ 5 WR5 IGBT IKW40N65WR5 with high switching frequencies up to 60 kHz in interleaved PFC application.

The block diagram of EVAL-PFC5KIKWWR5SYS is depicted in Figure 3, which shows the high-performance analogy controller UCC28070, TRENCHSTOP™ 5 IGBT IKW40N65WR5, low side gate driver 1ED44175 and rapid1 power silicon diode IDW60C65D1.

This reference design includes:

- Two-channel boost converters
- High-speed 650 V, 40 A reverse conducting TRENCHSTOP™ 5 WR5 IGBT in TO-247 package
- Gate driver ICs for WR5 IGBTs
- Rapid1 power silicon diode for boost rectification
- Loss-free current monitoring for switching current
- 15 V auxiliary power supply
- Connectors for easy setup

5 kW two-channel interleaved CCM PFC EVAL board

IKW40N65WR5, IDW60C65D1 and 1ED44175 in high frequency PFC application

The board at a glance

- External force cooling for high power application

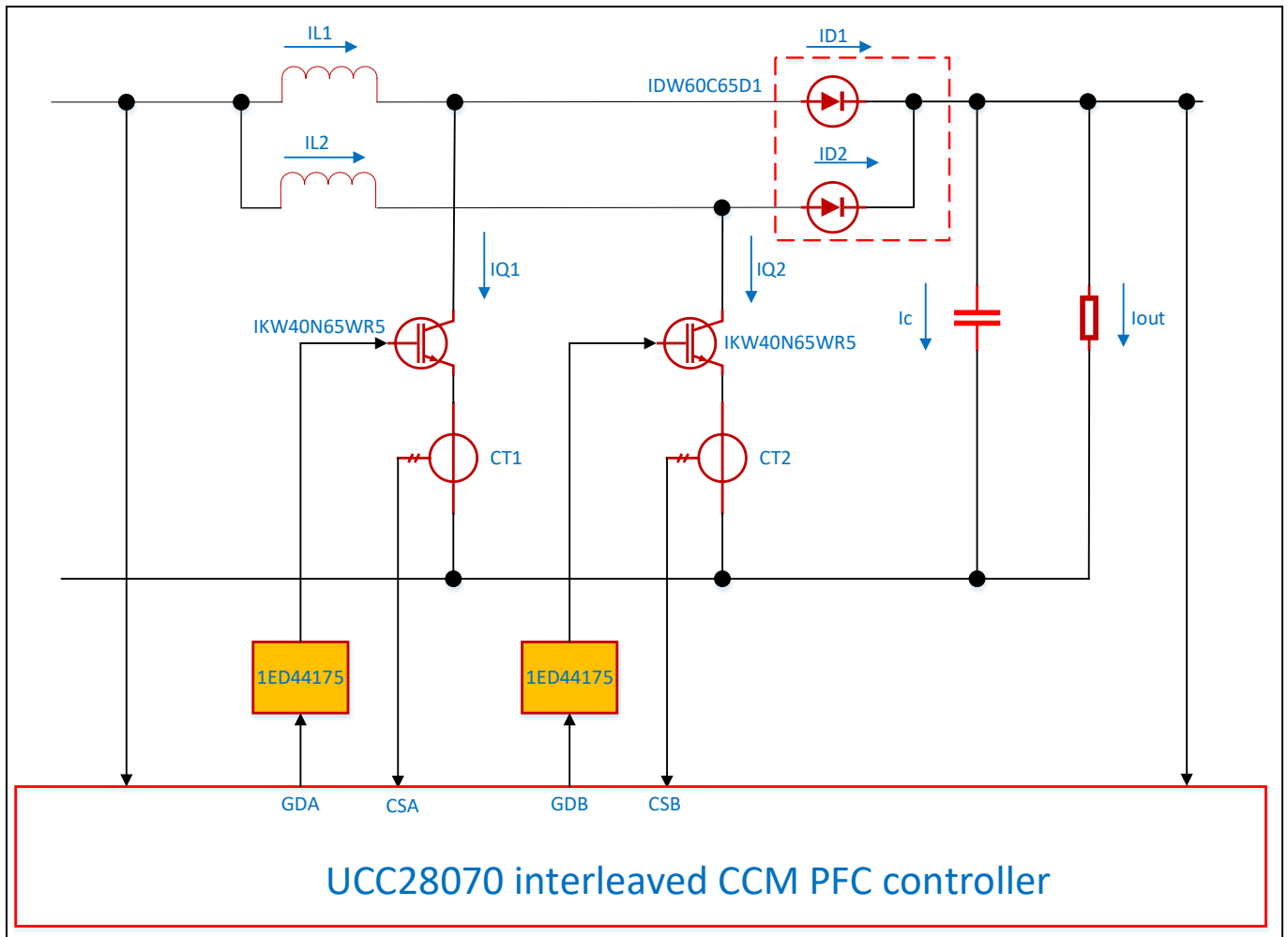

Figure 3 Block diagram of EVAL-PFC5KIKWWR5SYS

System and functional description

2 System and functional description

2.1 General overview

EVAL-PFC5KIKWWR5SYS is a referene design for 5 kW interleaved PFC for, but not limited to, floor-standing air conditioners in major home appliances.



Figure 4 EVAL-PFC5KIKWWR5SYS board view

The EVAL-PFC5KIKWWR5SYS evaluation board design characteristics include:

Board performance:

- High power factor, $PF > 0.995$
- Low THDi
- High efficiency

Control technology incorporated:

- CCM (continuous conduction mode) average current control
- Frequency-dithering for enhanced EMI reduction

Fault protection:

- Input undervoltage protection and overvoltage protection
- Output overvoltage protection
- Open-circuit protection on AC input and DC output
- Cycle-by-cycle peak current limiting
- Thermal shutdown for power semiconductors

5 kW two-channel interleaved CCM PFC EVAL board

IKW40N65WR5, IDW60C65D1 and 1ED44175 in high frequency PFC application



System and functional description

2.1.1 UCC28070 - analogy controller

Infineon does not have a dedicated interleaved PFC controller, so we chose a UCC28070 from TI, which is a popular choice in this field. Figure 5 is a simplified application diagram with UCC28070.

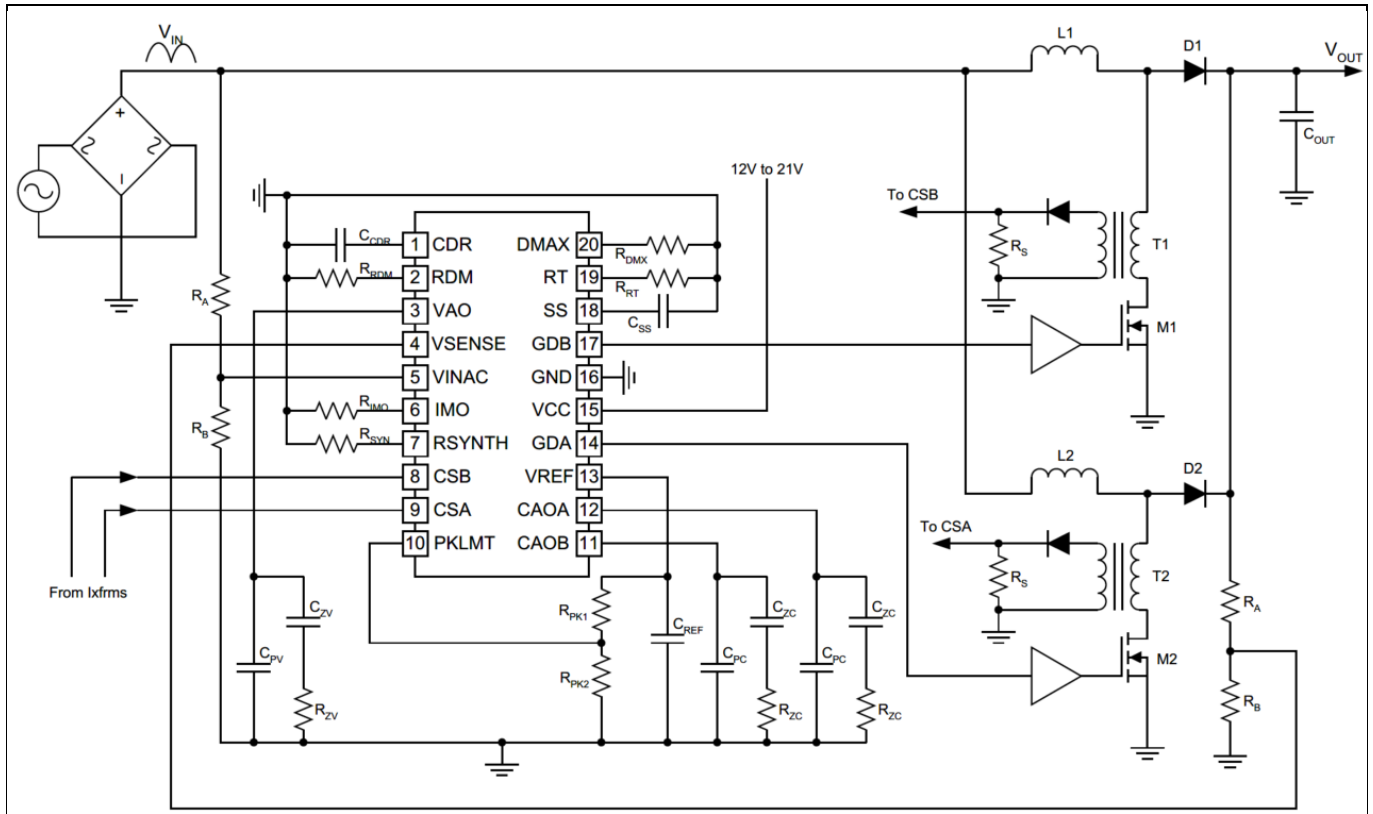

Figure 5 Simplified application diagram of UCC28070

2.1.2 IKW40N65WR5 - fast switching WR5 IGBT

IKW40N65WR5 is a high speed 650 V, 40 A reverse-conducting TRENCHSTOP™ 5 WR5 IGBT in TO-247 package. It is optimized for hard switching applications with a best price/performance ratio, and it is a good fit with mainstream designs of $F_{sw} > 20$ kHz. The IKW40N65WR5 features the following key characteristics:

- Very low V_{CEsat} of 1.35 V @25°C
- Low E_{tot}
- Soft recovery and low Q_{rr} for diode
- Good $R_{(G)off}$ controllability
- Low T_j & T_c for lower heatsink and cooling costs

2.1.3 IDW60C65D1 – rapid1 power silicon diode

IDW60C65D1 is a 650 V/ 60 A rapid1 diode, emitter controlled power silicon diode in common cathode configuration and in a TO-247 package, allowing design optimization for more compact dimensions, easier assembly and consequently lower costs. Here is summary of its features:

- Highest softness-factor for ultimate softness and low EMI filtering
- 1.35 V temperature-stable forward voltage (V_F)
- Lowest I_{rrm} to provide lowest turn-on losses on the boost switch

System and functional description

2.1.4 1ED44175 - low side gate driver

1ED44175 is an EiceDRIVER™ 25 V single-channel low-side non-inverting gate driver for IGBT with typical 2.6 A source and sink currents in a tiny 6-lead PG-SOT23 package. 1ED44175N01B provides cost and space savings by integrating the comparator. The new low-side gate driver utilizes Infineon’s proprietary latch immune CMOS technologies to enable a rugged monolithic construction while achieving best-in-class fault reporting accuracy with an OCP threshold tolerance of +/-5%. Its features are listed as follows:

- -0.246 V over current threshold with accurate ±5% tolerance
- Over current detection with negative voltage input
- Single pin for fault output and enable
- Programmable fault-clear time
- Under voltage lockout for IGBTs
- CMOS Schmitt-triggered inputs
- 3.3 V, 5 V and 15 V input logic compatible
- Output in phase with input
- -10 Vdc negative input capability of OCP pin
- 3 kV ESD HBM

2.2 Board specifications

Table 2 depicts the key specifications of the reference design used in the EVAL-PFC5KIKWWR5SYS.

Table 2 EVAL-PFC5KIKWWR5SYS specifications

NO.	Parameters	Symbol	Value
1	Output power	P_{out}	5000 watt
2	Input voltage range (rms)	V_{in}	180 V_{ac} to 264 V_{ac}
3	Input frequency range	f	50 Hz or 60 Hz
4	Ouput voltage	V_{DC}	400 V
5	Output ripple voltage	V_{ripple}	20 V
6	Inductance	L1, L2	53 μH
7	Switching frequency	F_s	60 kHz

System design

3 System design

To meet individual customer requirements and make the EVAL-PFC5KIKWWR5SYS evaluation board a basis for development or modification, all necessary technical data like schematics, layout and components are included in this chapter.

The EVAL-PFC5KIKWWR5SYS consists of three blocks: power stage, controller circuit and auxiliary supply, all of which are on the same board. All surface mounted devices are mounted on the bottom layer, enabling customers to modify parameters if necessary.

3.1 Schematics

There are a total of 6 schematic diagrams in its design. The figures below describe their functions respectively.

Figure 6 shows the converter's EMI filter, soft start control, and diode rectifiers. Connectors X1, X3 and X6 connect to grid line, neutral and ground respectively. Three MOVs (R58, R60 and R61) and gase discharge tube GT1 consist of the surge protection circuit. R54 and R55 limit input current ramp slope at startup. Once the voltage of output capacitors is up to about 230V, the K1 relay turns on and bypasses R54 and R55. At this point, the PFC converter works with high efficiency.

5 kW two-channel interleaved CCM PFC EVAL board IKW40N65WR5, IDW60C65D1 and 1ED44175 in high frequency PFC application



System design

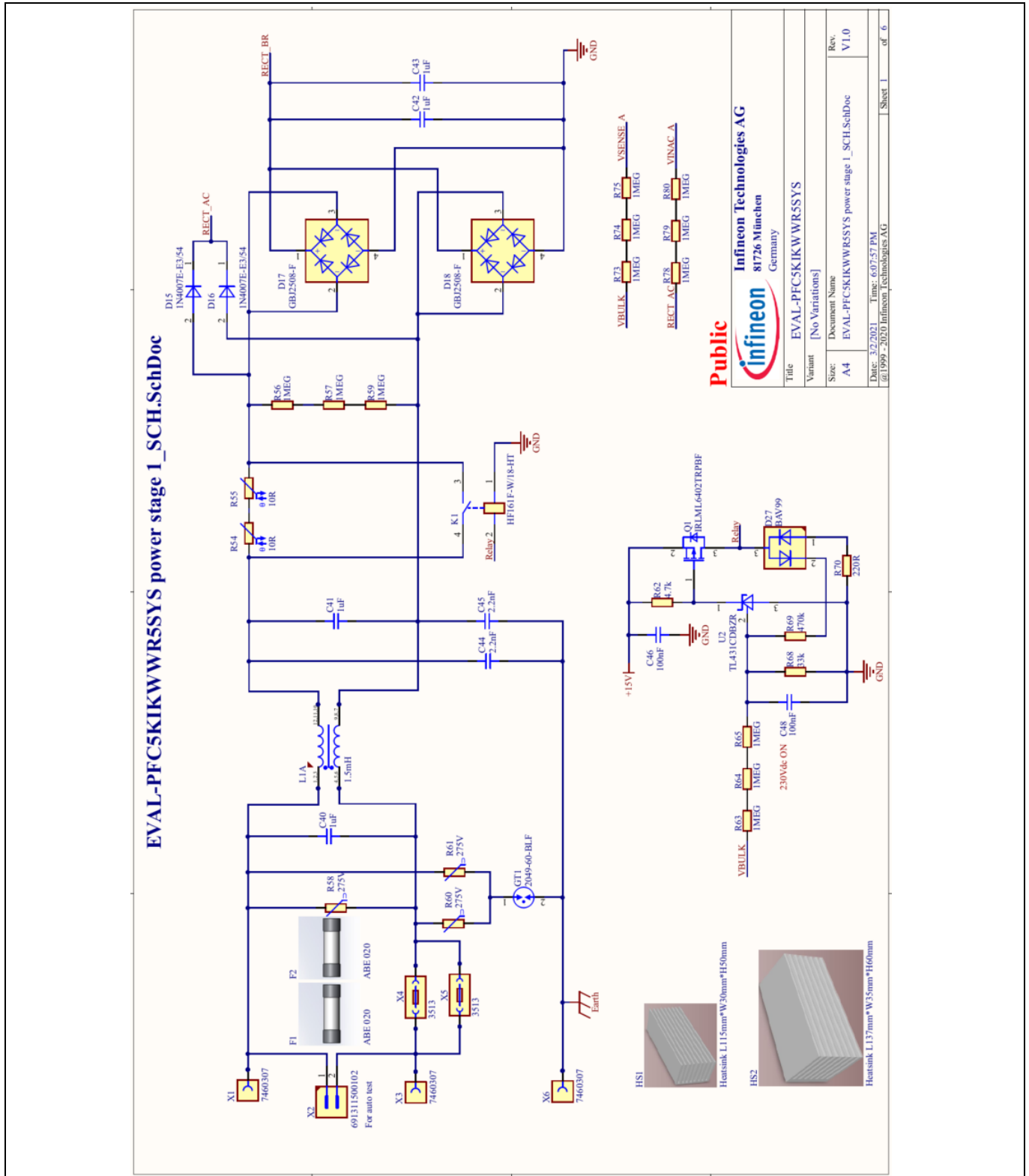

Figure 6 EMI filter, soft start control, and rectifiers of EVAL-PFC5KIKWWR5SYS

In Figure 7, two-channel boost converters connect in parallel with 180° out-of-phase control. Each channel has a WR5 IGBT IKW40N65WR5 as main switch, a rapid1 fast-recovery diode IDW60C65D1 with common cathode as boost diodes for both channels, in paratical applications, customers can also select two seprated silicon fast-recovery diodes or two SiC diodes to replace this common cathode diode, and put them as D21 and D22. A current transformer monitors the IGBT current for normal operation and cycle-by-cycle current limiting. Each gate driver

5 kW two-channel interleaved CCM PFC EVAL board IKW40N65WR5, IDW60C65D1 and 1ED44175 in high frequency PFC application



System design

1ED44175 matches one IGBT. Two boost inductors with NPH-L material comes from POCO have better performance than inductors with traditional powder materials.

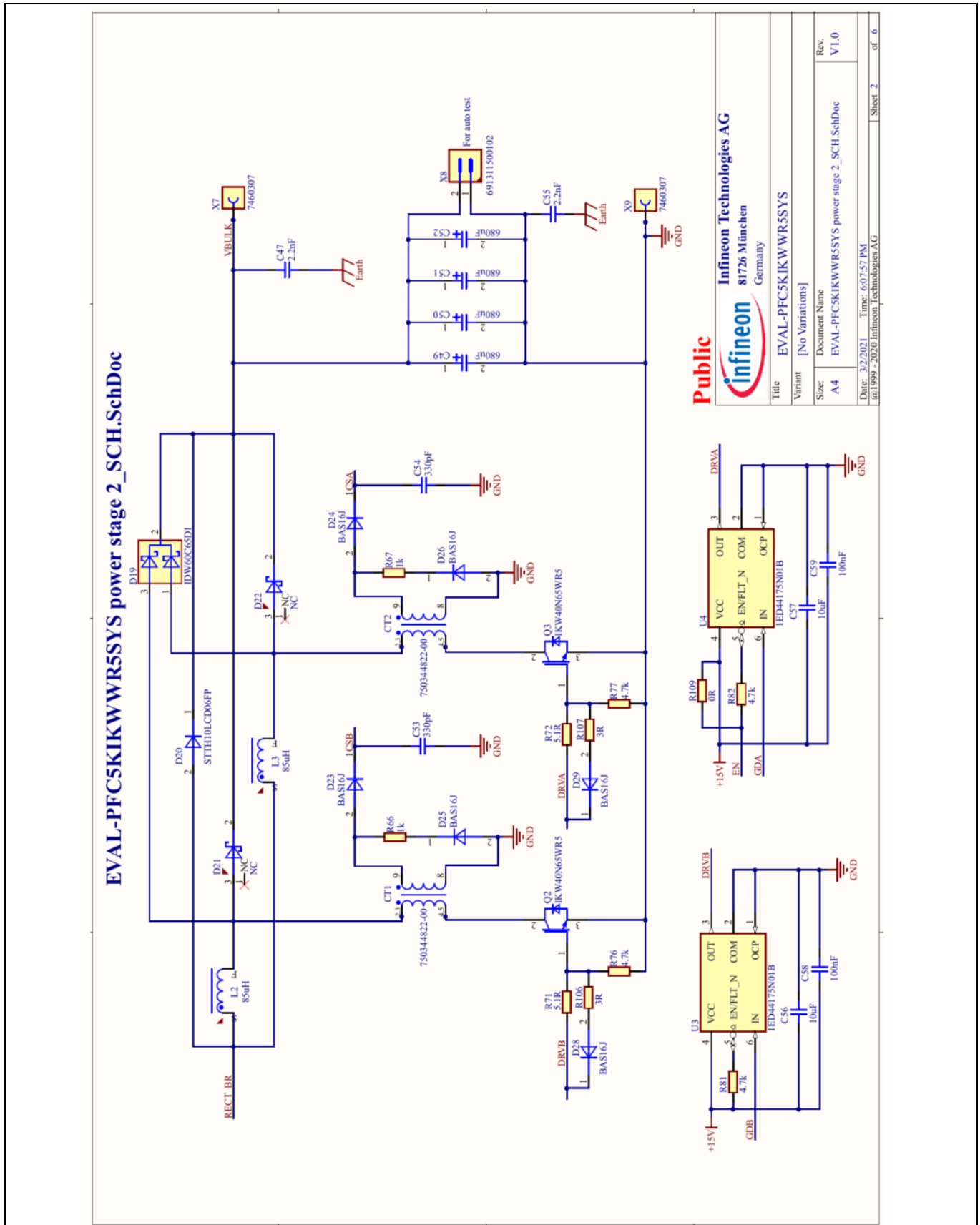

Figure 7 Interleaved PFC power stage of EVAL-PFC5KIKWWR5SYS

5 kW two-channel interleaved CCM PFC EVAL board IKW40N65WR5, IDW60C65D1 and 1ED44175 in high frequency PFC application



System design

Figure 8 depicts the UCC28070 analog control and its parameter settings with external resistors and capacitors. Potentiometer R115 sets converter switching frequency, it is very easy for customer to adjust switching frequency.

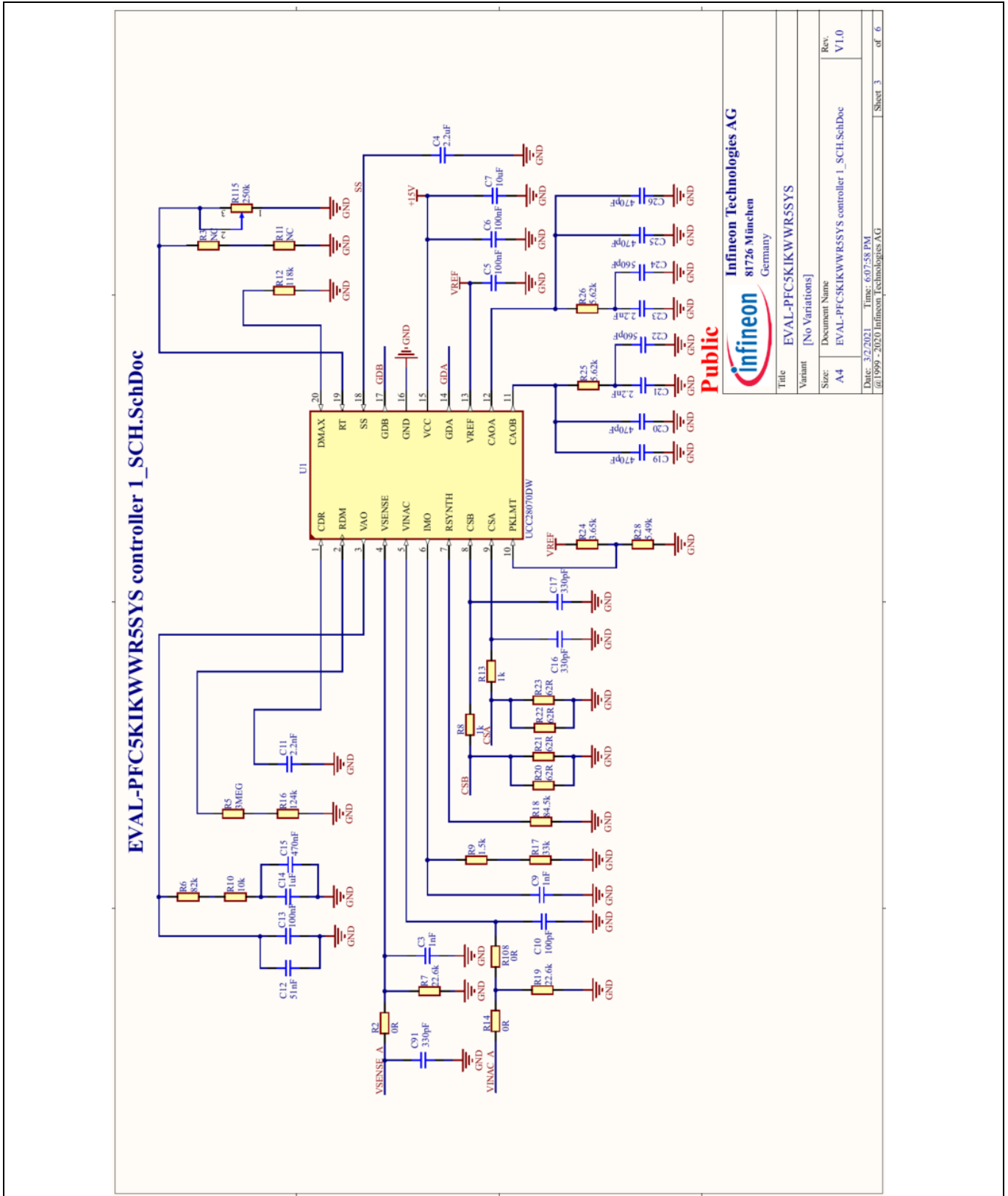

Figure 8 UCC28070 parameter settings of EVAL-PFC5KIKWWR5SYS

5 kW two-channel interleaved CCM PFC EVAL board IKW40N65WR5, IDW60C65D1 and 1ED44175 in high frequency PFC application



System design

Great care was taken to select the proper value for RC filters applied to V_{SENSE} and V_{INAC} , as it may be beneficial in a noisy environment to avoid the destabilizing effects of excess noise on these inputs. If applied, the RC time-constant for these two pins should not exceed 100 μ s. More information about how to control the UCC28070 with external components can be found in [1].

Figure 9 shows the fault protection of this board: thermal shutdown of the power semiconductors is implemented by an external comparator, in case the cooling fans fixed on the mechanical box do not work or fail, the resistance of NTC fixed on heatsink decreases dramatically, and the SS pin of UCC28070 is pulled-down to ground, in which case both gate signals are disabled.

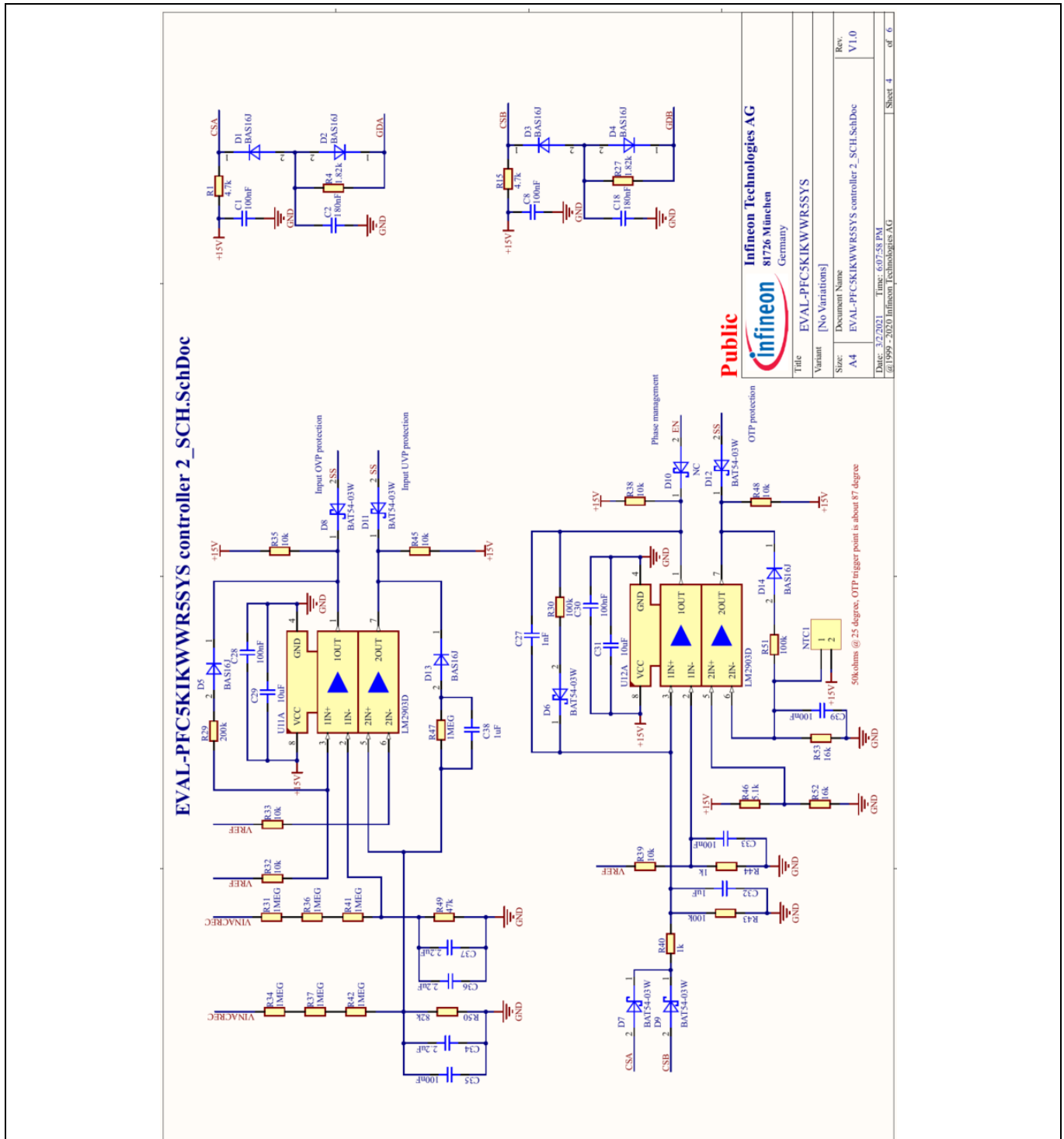

Figure 9 Protections of EVAL-PFC5KIKWWR5SYS

5 kW two-channel interleaved CCM PFC EVAL board IKW40N65WR5, IDW60C65D1 and 1ED44175 in high frequency PFC application



System design

Because UCC28070 already has an integrated output over voltage protection via the continuous monitoring of V_{SENSE} , the input over-voltage protection and under-voltage protection in this converter are implemented by an external comparator, both of which are also connected to the SS pin of UCC28070.

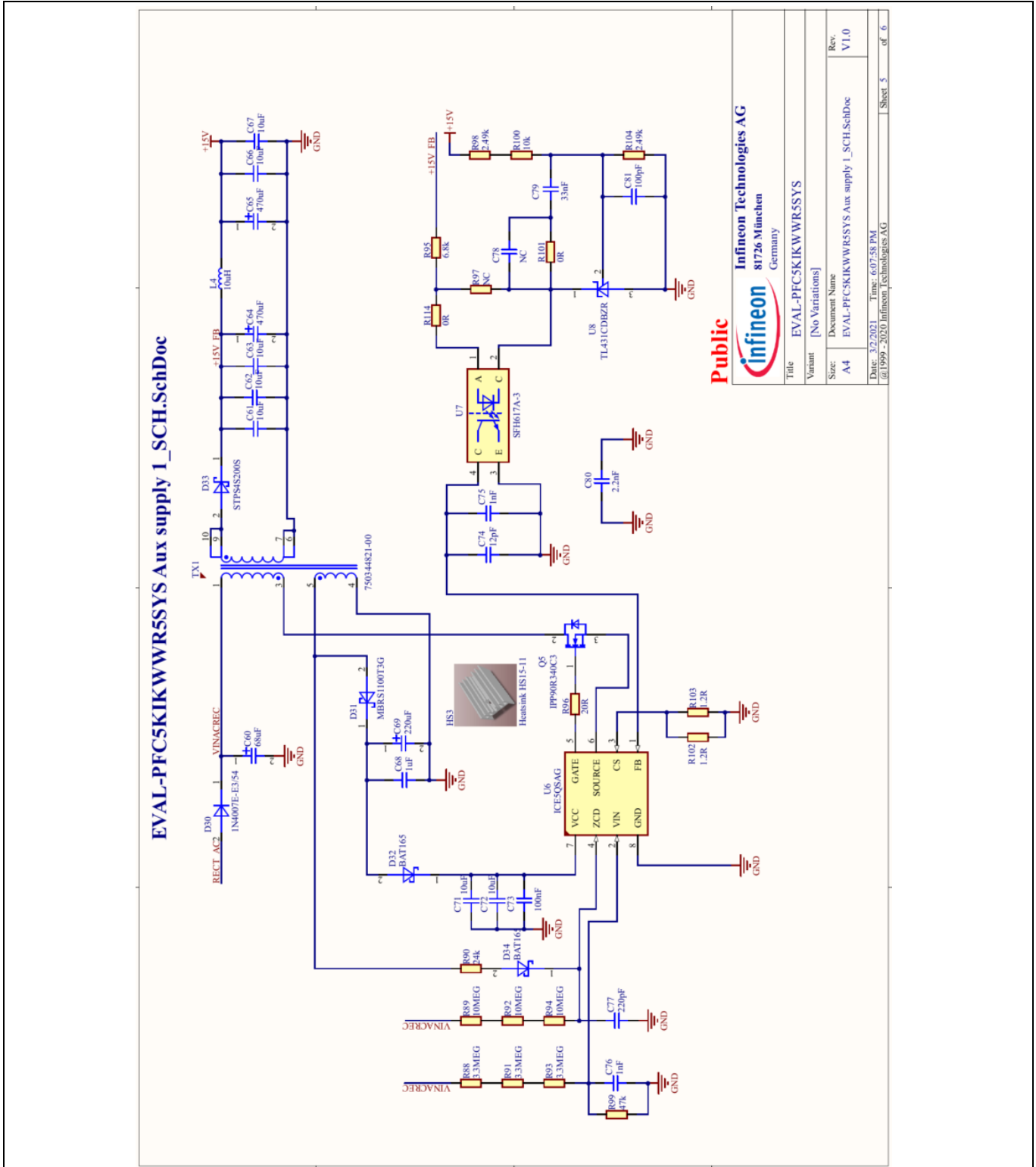

Figure 10 Auxiliary supply of EVAL-PFC5KIKWWR5SYS

Figure 10 depicts the auxiliary supply of the evaluation board, supplying the voltage to the controller circuit, gate drivers and cooling fans. ICE5QSAG [2] is a QR mode controller for soft switching operation of Q5, it helps to

5 kW two-channel interleaved CCM PFC EVAL board

IKW40N65WR5, IDW60C65D1 and 1ED44175 in high frequency PFC application



System design

increase system efficiency. For a simplified design of the flyback transformer (TX1 in Figure 10), there is only one secondary winding with an output voltage of 15 V, which is an optimized voltage for driving IGBTs.

However, the maximum recommended voltage for cooling fans is 13.8V, therefore, as shown in Figure 11, two LDO chips IFX1963 provide about 13.6 V voltage to fans directly, without fan speed regulation.

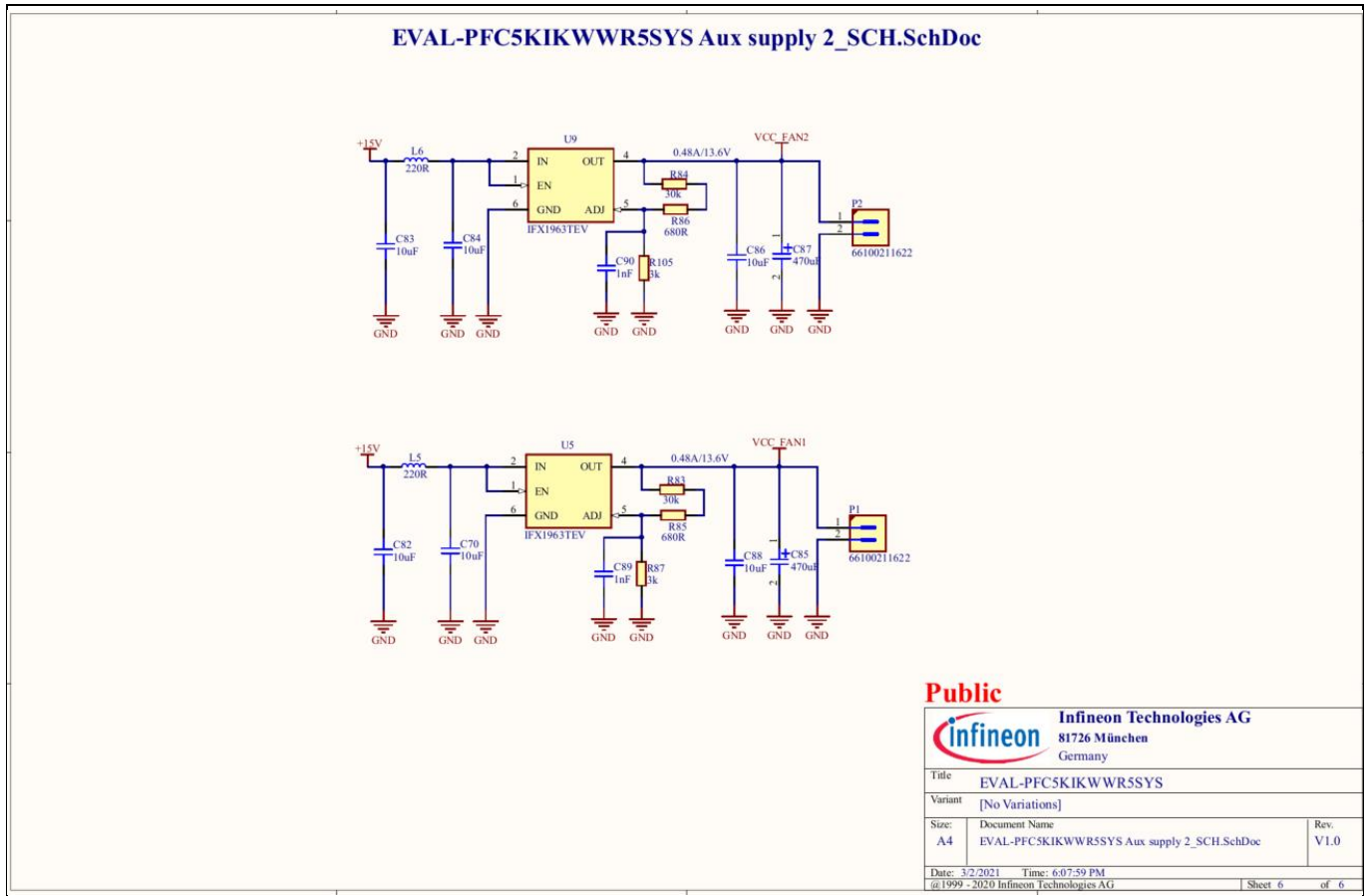

Public	
Infineon Technologies AG 81726 München Germany	
Title EVAL-PFC5KIKWWR5SYS	
Variant [No Variations]	
Size: A4	Document Name EVAL-PFC5KIKWWR5SYS Aux supply 2_SCH.SchDoc
	Rev. V1.0
Date: 3/2/2021 Time: 6:07:59 PM	
©1999 - 2020 Infineon Technologies AG	
Sheet 6	of 6

Figure 11 Low dropout regulator for fans of EVAL-PFC5KIKWWR5SYS

3.2 Layout

The layout of this evaluation board is helpful for customers to understand the placements of components and the routing of wires for whole board. As a default, the PCB has four electrical layers with 70 μm of copper and dimensions of 244 mm × 142 mm. The PCB board thickness is 2 mm. Please check Infineon’s website or contact Infineon’s technical support team to obtain more detailed information and the latest Gerber files.

System design

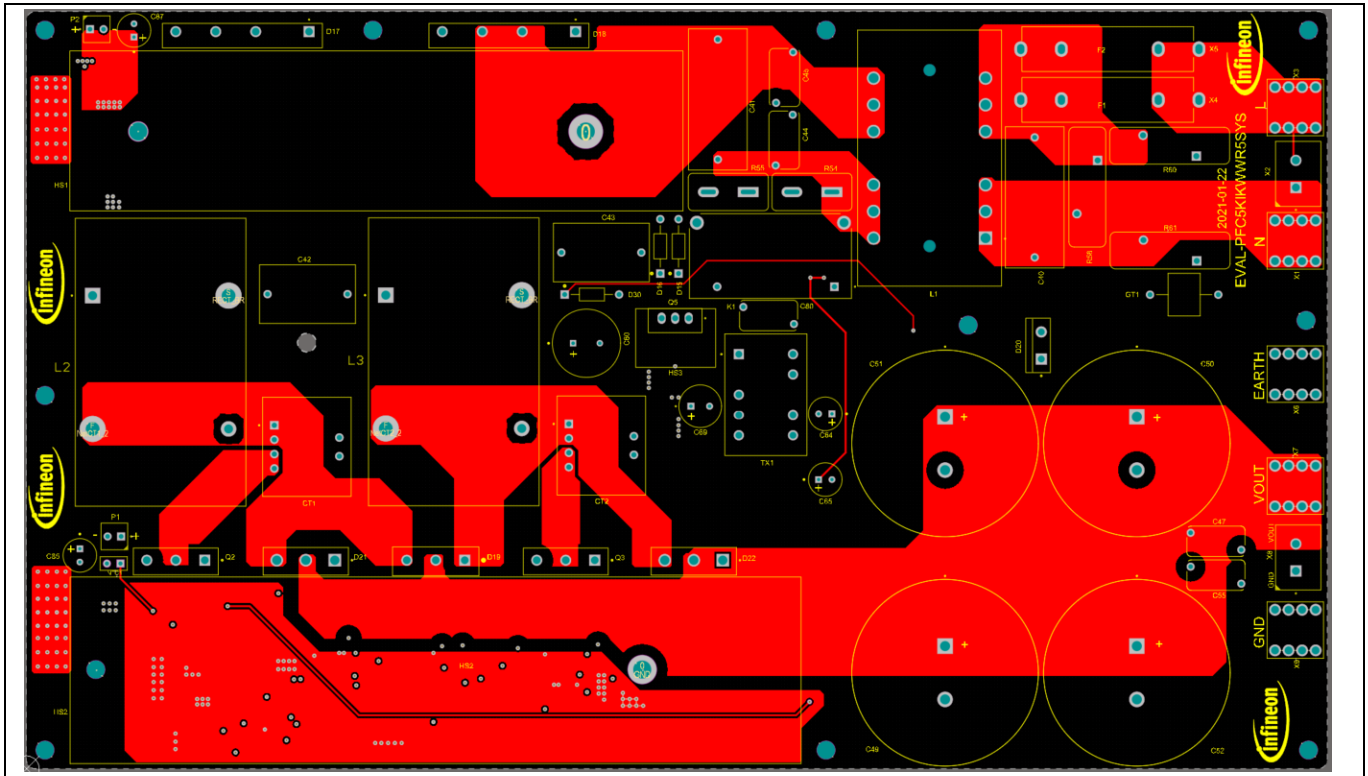

Figure 12 Top-layer routing of EVAL-PFC5KIKWWR5SYS

Figure 12 illustrates the top-layer routing of this evaluation board.

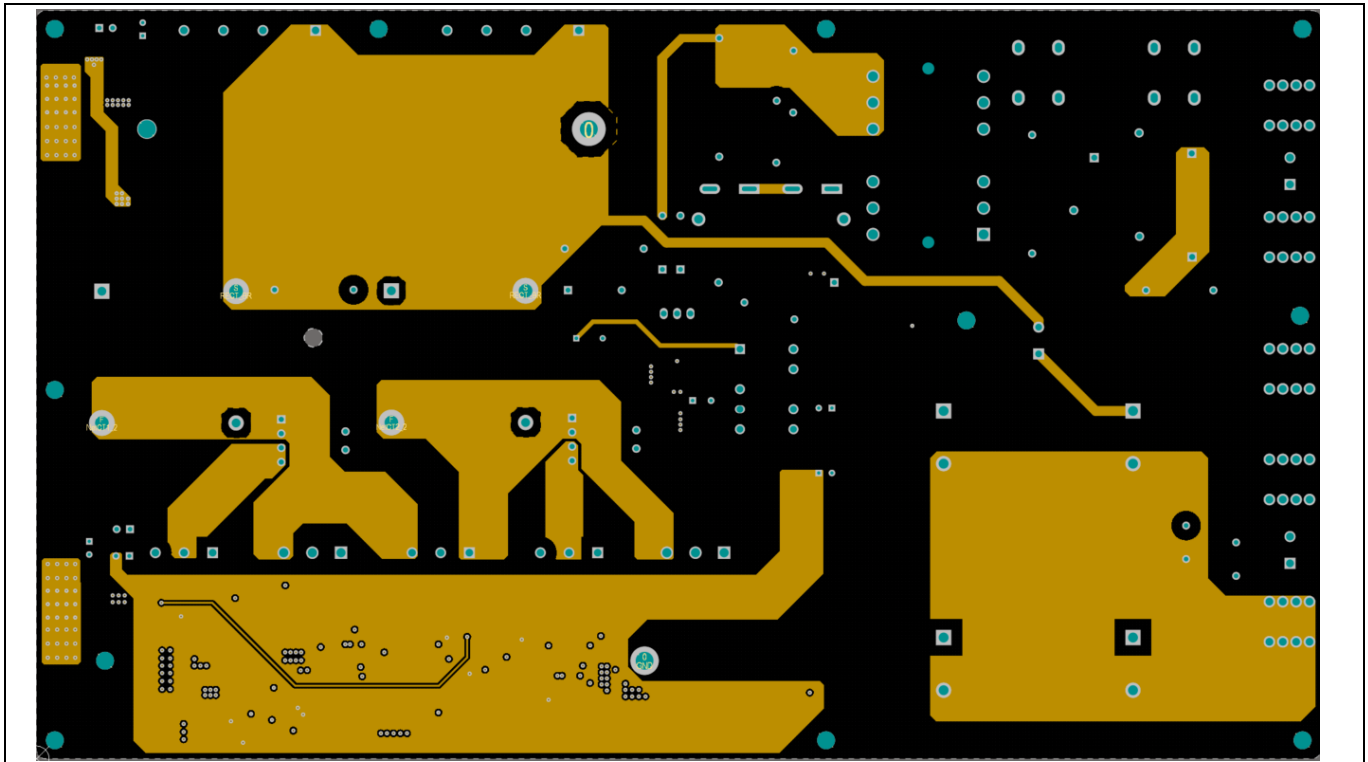

Figure 13 Mid-layer 1 routing of EVAL-PFC5KIKWWR5SYS

Figure 13 depicts the mid-layer 1 routing of this evaluation board.

System design

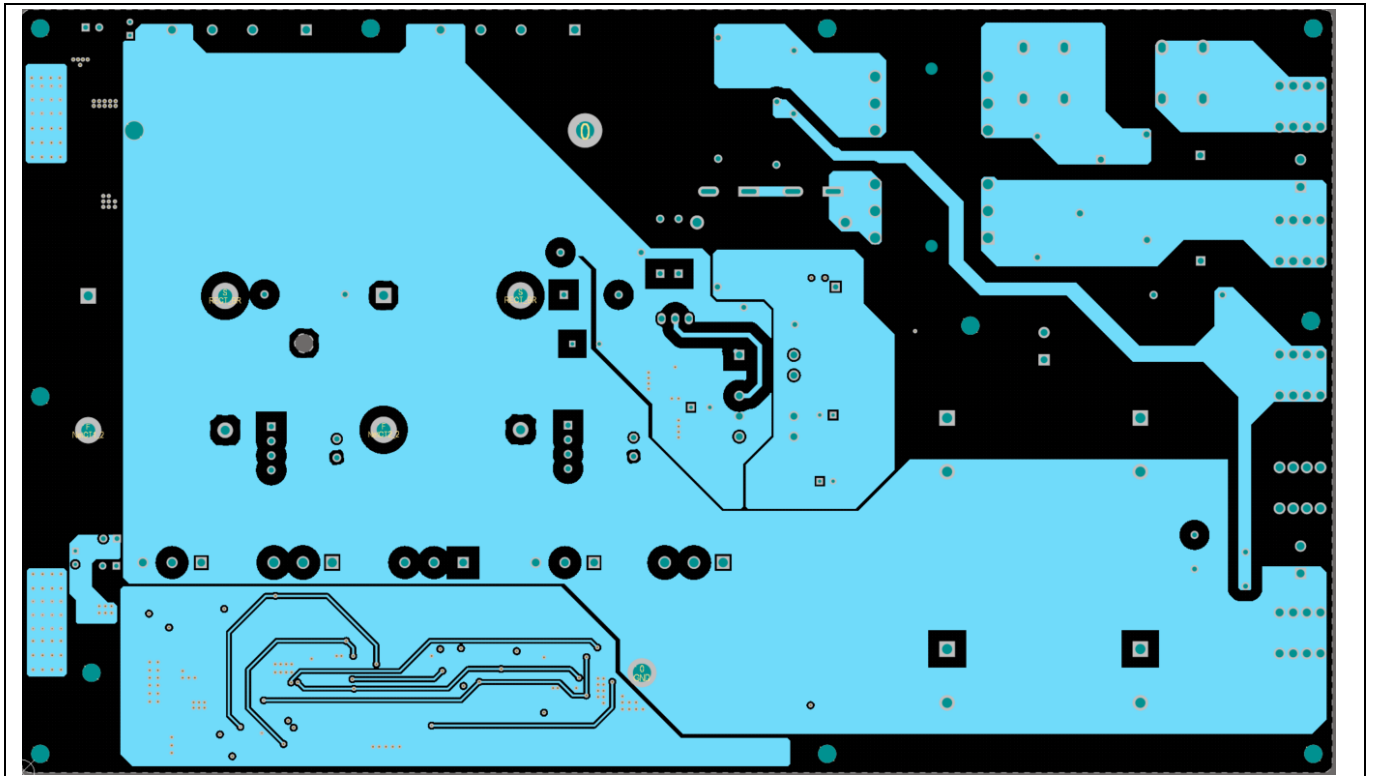

Figure 14 Mid-layer 2 routing of EVAL-PFC5KIKWWR5SYS

Figure 14 shows the mid-layer 2 routing of this evaluation board.

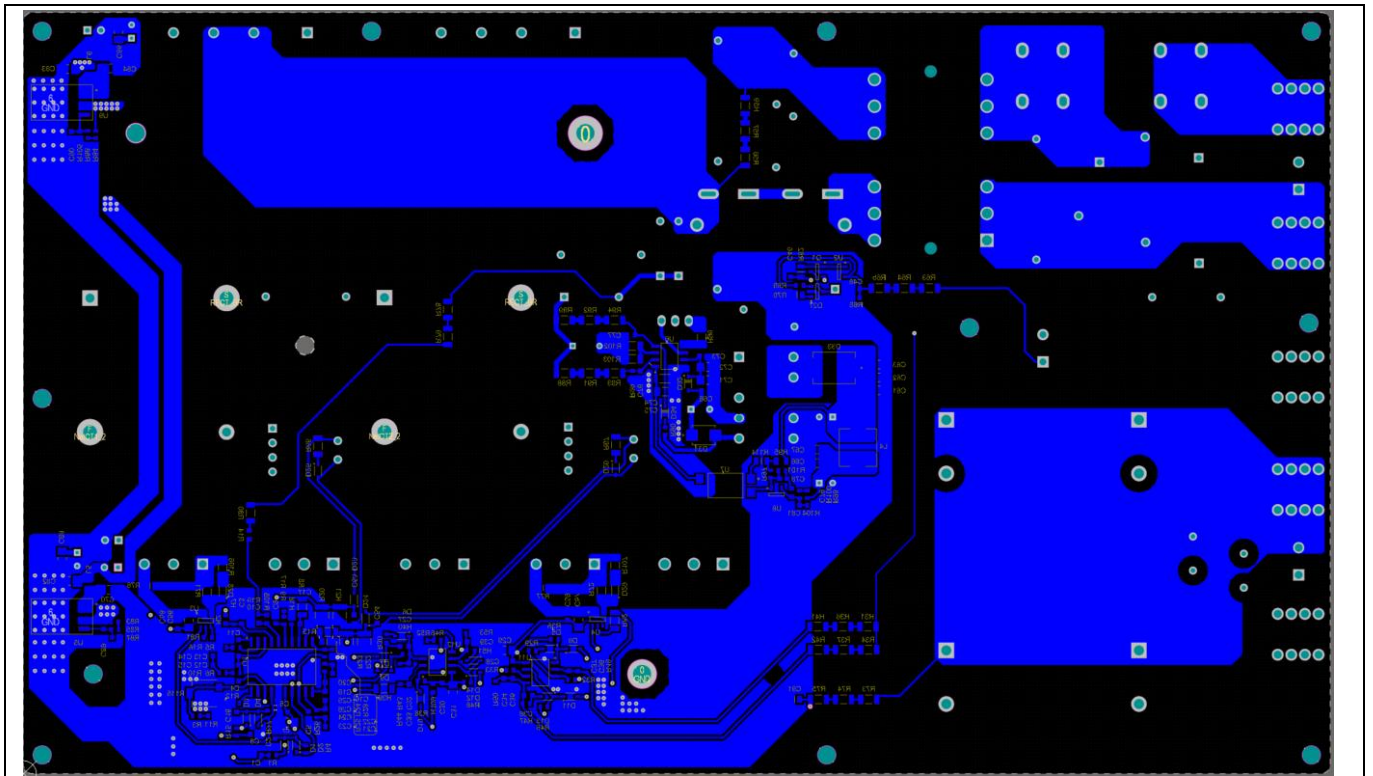

Figure 15 Bottom-layer routing of EVAL-PFC5KIKWWR5SYS

Figure 15 illustrates the bottom-layer routing of this evaluation board.

5 kW two-channel interleaved CCM PFC EVAL board

IKW40N65WR5, IDW60C65D1 and 1ED44175 in high frequency PFC application



System design

3.3 Bill of material

The complete bill of material is available on the download section of the Infineon homepage. A log-in is required to download this material.

Table 3 BOM of evaluation board

Quantity	Ref Designator	Value	Description	Manufacturer	Manufacturer P/N
15	C1, C5, C6, C8, C13, C28, C30, C33, C35, C39, C46, C48, C58, C59, C73	100nF	Chip Monolithic Ceramic Capacitor	MuRata	GRM188R71E104KA01,
2	C2, C18	180nF	Chip Monolithic Ceramic Capacitor	MuRata	GCM188R71E184JA55
6	C3, C9, C27, C76, C89, C90	1nF	Chip Monolithic Ceramic Capacitor	MuRata	GRM188R71E102KA01,
4	C4, C34, C36, C37	2.2uF	Chip Monolithic Ceramic Capacitor	MuRata	GRM188R61E225KA12
18	C7, C29, C31, C56, C57, C61, C62, C63, C66, C67, C70, C71, C72, C82, C83, C84, C86, C88	10uF	Commerical Grade Multilayer Ceramic Chip Capacitor	TDK Corporation	C3216X7R1E106K160AB
2	C10, C81	100pF	Multilayer Ceramic Chip Capacitor, C Series, Commercial Grade, General	TDK Corporation	C1608X7R1H101M
3	C11, C21, C23	2.2nF	Chip Monolithic Ceramic Capacitor	MuRata	GRM188R71E222KA01
1	C12	51nF	Chip Monolithic Ceramic Capacitor	MuRata	GCM188R71E473KA37
4	C14, C32, C38, C68	1uF	Chip Monolithic Ceramic Capacitor	MuRata	GRM188R71E105KA12
1	C15	470nF	Chip Monolithic Ceramic Capacitor	MuRata	GRM188R71C474KA88
2	C16, C91	330pF	Chip Monolithic Ceramic Capacitor	MuRata	GRM216R71H331KA01
3	C17, C53, C54	330pF	Chip Monolithic Ceramic Capacitor	MuRata	GRM188R71H331KA01
4	C19, C20, C25, C26	470pF	Chip Monolithic Ceramic Capacitor	MuRata	GRM188R71H471KA01
2	C22, C24	560pF	Chip Monolithic Ceramic Capacitor	MuRata	GRM1885C1E561JA01
2	C40, C41	1uF	Metallized Polypropylene Film Capacitor	TDK Corporation	B32923C3105M000
1	C42	1uF	Metallized Polyester Film Capacitor	Epcos	B32522N6105K000
1	C43	NC	Metallized Polyester Film Capacitor	Epcos	B32522N6105K000
5	C44, C45, C47, C55, C80	2.2nF	AC Line Rated Ceramic Disc Capacitor Class X1, 760 VAC / Class Y1, 500 VAC	Vishay	440LD22-R
4	C49, C50, C51, C52	680uF	CAP / ELCO / 680uF / 450V / 20% / - / -40°C to 105°C / 10.00mm Pitch X 35.00mm Dia X 62.00 mm H body / - / -	Aishi	ELP2WM681R60KT
1	C60	68uF	Miniature Aluminum Electrolytic Capacitor	Aishi	EHL2WM680W50OT
4	C64, C65, C85, C87	470uF	Aluminum Electrolytic Capacitor / FC Series	Aishi	SPD1CM102G12000RAXX X
1	C69	220uF	Miniature Aluminium Electrolytic Capacitor	Aishi	EML1EM221F09OT
1	C74	12pF	Chip Monolithic Ceramic Capacitor	MuRata	GRM31A5C2H120JW01

5 kW two-channel interleaved CCM PFC EVAL board

IKW40N65WR5, IDW60C65D1 and 1ED44175 in high frequency PFC application



System design

Quantity	Ref Designator	Value	Description	Manufacturer	Manufacturer P/N
1	C75	1nF	Chip Monolithic Ceramic Capacitor	MuRata	GRM319R71H102JA01
1	C77	220pF	Chip Monolithic Ceramic Capacitor	MuRata	GRM188R71H221KA01
1	C78	NC	Multilayer Ceramic Chip Capacitor, C Series, Commercial Grade, General	TDK Corporation	C1608X7R1H101M
1	C79	33nF	Chip Monolithic Ceramic Capacitor	MuRata	GRM188R71E333JA01
2	CT1, CT2	750344822-00	Transformer, 10.50mH, Turn Ratio 400:1	Würth Elektronik	750344822-00
13	D1, D2, D3, D4, D5, D13, D14, D23, D24, D25, D26, D28, D29	BAS16J	Silicon Switching Diode	Nexperia	BAS16J
6	D6, D7, D8, D9, D11, D12	BAT54-03W	Silicon Schottky Diode	Infineon Technologies	BAT54-03W
1	D10	NC	Silicon Schottky Diode	Infineon Technologies	BAT54-03W
3	D15, D16, D30	1N4007E-E3/54	General Purpose Plastic Rectifier	Vishay	1N4007E-E3/54
2	D17, D18	GBJ2508-F	Glass Passivated Bridge Rectifier 600V	Micro Commercial Components	GBJ2508-F
1	D19	IDW60C65D1	650 V rapid 1 Diode, IF 30/60A, TO247-3	Infineon Technologies	IDW60C65D1
1	D20	STTH10LCD06FP	Turbo2 Ultrafast High Voltage Rectifier For Flat Panel Displays	STMicroelectronics	STTH10LCD06FP
2	D21, D22	NC	650 V rapid 1 Diode, 30A, TO247-3	Infineon Technologies	IDW30E65D1
1	D27	BAV99	High-Speed Switching Diode	Nexperia	BAV99
1	D31	MBRS1100T3G	Schottky Power Rectifier	ON Semiconductor	MBRS1100T3G
2	D32, D34	BAT165	Medium Power AF Schottky Diode	Infineon Technologies	BAT165
1	D33	STPS4S200S	Surface Mount Schottky Barrier Rectifier	STMicroelectronics	STPS4S200S
2	F1, F2	12.8mR	Fast-Acting Fuse Cartridge, 20A/250V	Conquer	ABE 020
1	GT1	2049-60-BLF	RES / STD / - / - / 30% / - / -30°C to 85°C / 12.80mm pitch, 6.00 mm L X 8.00 mm W, 8.3 mm H body / - / -	Bourns	2049-60-BLF
1	HS1	Heatsink L115mm*W30mm*H50mm	Heatsink L115mm*W30mm*H50mm	-	Heatsink L115mm*W30mm*H50mm
1	HS2	Heatsink L137mm*W35mm*H60mm	Heatsink L137mm*W35mm*H60mm	-	Heatsink L137mm*W35mm*H60mm
1	HS3	Heatsink HS15-11	Heatsink L15*W11	-	Heatsink HS15-11
1	K1	HF161F-W/18-HT	Solar Relay, Applicable to inverter used for photovoltaic power generation systems	HongFa	HF161F-W/18-HT
1	L1	1.5mH	Common Mode Power Line Choke	Würth Elektronik	7448063801
2	L2, L3	85uH	IND / STD / 85uH / - / 10% / - / 16mR / THT / Inductor, THT, 4 pin, 54.00 mm L X 32.00 mm W X 56.00 mm H body / THT / -	POCO	PI200273V1
1	L4	10uH	IND / STD / 10uH / 4A / 20% / -40°C to 150°C / 33mR / SMD / Inductor, SMD, 6.90mm L X	Würth Elektronik	744314101

5 kW two-channel interleaved CCM PFC EVAL board

IKW40N65WR5, IDW60C65D1 and 1ED44175 in high frequency PFC application



System design

Quantity	Ref Designator	Value	Description	Manufacturer	Manufacturer P/N
			6.90mm W X 5.00mm H body / SMD / -		
2	L5, L6	220R	Chip Ferrite Bead	Würth Elektronik	742792031
1	NTC1	AYN-MF56-503F-3950FB-28#-100	Header, 2-Pin		AYN-MF56-503F-3950FB-28#-100
2	P1, P2	66100211622	CONNECTOR HEADER VERT 2POS 2.54MM	Würth Elektronik	66100211622
1	Q1	IRLML6402TRPBF	HEXFET P-Channel Power MOSFET, 20V, 3.7A	Infineon Technologies	IRLML6402TRPBF
2	Q2, Q3	IKW40N65WR5	High speed fast IGBT in TRENCHSTOPTM 5 technology, VCE 650V, IC 40A	Infineon Technologies	IKW40N65WR5
1	Q5	IPP90R340C3	900V CoolMOS C3 Power Transistor, RDS(on) 340mOhm	Infineon Technologies	IPP90R340C3
3	R1, R15, R81	4.7k	General Purpose Chip Resistor	Yageo	RC0603FR-074K7L
4	R2, R14, R108, R109	0R	0R/75V	Panasonic	ERJ3GEY0R00V
1	R3	NC	Standard Thick Film Chip Resistor	Vishay	CRCW0603115KFK,
1	R11	NC	Standard Thick Film Chip Resistor	Vishay	CRCW060310K0FK
1	R97	NC	Standard Thick Film Chip Resistor	Vishay	CRCW06031K20FK
2	R4, R27	1.82k	Standard Thick Film Chip Resistor	Vishay	CRCW06031K82FK
1	R5	3MEG	Standard Thick Film Chip Resistor	Vishay	CRCW06033M00FK
2	R6, R50	82k	Standard Thick Film Chip Resistor	Vishay	CRCW060382K0FK
2	R7, R19	22.6k	Standard Thick Film Chip Resistor	Vishay	CRCW060322K6FK
3	R8, R66, R67	1k	Standard Thick Film Chip Resistor	Vishay	CRCW12061K00FK
1	R9	1.5k	Standard Thick Film Chip Resistor	Vishay	CRCW06031K50FK
8	R10, R32, R33, R35, R38, R45, R48, R100	10k	Standard Thick Film Chip Resistor	Vishay	CRCW060310K0FK
1	R12	118k	Standard Thick Film Chip Resistor	Vishay	CRCW0603118KFK
1	R13	1k	1k/200V/1%	TT Electronics	ASC1206-1K0FT5
1	R16	124k	Standard Thick Film Chip Resistor	Vishay	CRCW0603124KFK
1	R17	33k	Standard Thick Film Chip Resistor	Vishay	CRCW060333K0FK
1	R18	84.5k	Standard Thick Film Chip Resistor	Vishay	CRCW060384K5FK
4	R20, R21, R22, R23	62R	Standard Thick Film Chip Resistor	Vishay	CRCW121062R0FK
1	R24	3.65k	Standard Thick Film Chip Resistor	Vishay	CRCW06033K65FK
2	R25, R26	5.62k	Standard Thick Film Chip Resistor	Vishay	CRCW06035K62FK
1	R28	5.49k	Standard Thick Film Chip Resistor	Vishay	CRCW06035K49FK
1	R29	200k	Standard Thick Film Chip Resistor	Vishay	CRCW0603200KFK
3	R30, R43, R51	100k	General Purpose Chip Resistor	Yageo	RC0603FR-07100KL
18	R31, R34, R36, R37, R41, R42, R56, R57, R59, R63, R64, R65, R73, R74, R75, R78, R79, R80	1MEG	Standard Thick Film Chip Resistor	Vishay	CRCW12061M00FK

5 kW two-channel interleaved CCM PFC EVAL board

IKW40N65WR5, IDW60C65D1 and 1ED44175 in high frequency PFC application



System design

Quantity	Ref Designator	Value	Description	Manufacturer	Manufacturer P/N
1	R39	10k	General Purpose Chip Resistor	Yageo	RC1206FR-0710KL
2	R40, R44	1k	Standard Thick Film Chip Resistor	Vishay	CRCW06031K00FK
1	R46	5.1k	Standard Thick Film Chip Resistor	Vishay	CRCW06035K10FK
1	R47	1MEG	Standard Thick Film Chip Resistor	Vishay	CRCW06031M00FK
2	R49, R99	47k	Standard Thick Film Chip Resistor	Vishay	CRCW060347K0FK
2	R52, R53	16k	Standard Thick Film Chip Resistor	Vishay	CRCW060316K0FK
2	R54, R55	10R	NTC Thermistor for Inrush Current Limiting	Epcos	B57237S0100M000
3	R58, R60, R61	275V	Multi Pulse Handling SIOV Metal Oxide Varistor	Epcos	B72220S0271K101
3	R62, R76, R77	4.7k	Standard Thick Film Chip Resistor	Vishay	CRCW08054K70FK
1	R68	33k	33k/50V/1%	ROHM Semiconductors	MCR03ERTF3302
1	R69	470k	Standard Thick Film Chip Resistor	Vishay	CRCW0603470KFK
1	R70	220R	Standard Thick Film Chip Resistor	Vishay	CRCW0805220RFK
2	R71, R72	5.1R	Standard Thick Film Chip Resistor	Vishay	CRCW12065R10FK
1	R82	4.7k	Standard Thick Film Chip Resistor	Vishay	CRCW12064K70FK
2	R83, R84	30k	Standard Thick Film Chip Resistor	Vishay	CRCW060330K0FK
2	R85, R86	680R	Standard Thick Film Chip Resistor	Vishay	CRCW0603680RFK
2	R87, R105	3k	3k/50V/1%	ROHM Semiconductors	MCR03EZPF3001
3	R88, R91, R93	3.3MEG	Standard Thick Film Chip Resistor	Vishay	CRCW12063M30FK
3	R89, R92, R94	10MEG	Standard Thick Film Chip Resistor	Vishay	CRCW120610M0FK
1	R90	24k	Standard Thick Film Chip Resistor	Vishay	CRCW060324K0FK
1	R95	6.8k	General Purpose Chip Resistor	Yageo	RC0805FR-076K8L
1	R96	20R	Standard Thick Film Chip Resistor	Vishay	CRCW120620R0FK
2	R98, R104	2.49k	Standard Thick Film Chip Resistor	Vishay	CRCW06032K49FK
1	R101	0R	Standard Thick Film Chip Resistor	Vishay	CRCW06030000Z0
2	R102, R103	1.2R	Standard Thick Film Chip Resistor	Vishay	CRCW12061R20FK
2	R106, R107	3R	3R/0.5W/1%	Panasonic	ERJ8BQF3R0V
1	R114	0R	Standard Thick Film Chip Resistor	Vishay	CRCW08050000Z0
1	R115	250k	RES / VAR / 250k / 250mW / 20% / 100ppm/K / -55°C to 125°C / 3 pin, 5.00mm L X 4.50mm W X 2.85mm H Body / SMD / -	Bourns	3314G-1-254E
1	TX1	750344821-00	Transformer 10-Terminal EXT, THT, Horizontal, EE Style Bobbins, EE20	Würth Elektronik Midcom	750344821-00
1	U1	UCC28070DW	PFC controller	Texas Instruments	UCC28070DW
2	U2, U8	TL431CDBZR	Precision Programmable Reference	Texas Instruments	TL431CDBZR
2	U3, U4	1ED44175N01B	Gate Drivers LOW SIDE DRIVERS	Infineon Technologies	1ED44175N01B
2	U5, U9	IFX1963TEV	1.5A Low Dropout Linear Voltage Regulator	Infineon Technologies	IFX1963TEV

5 kW two-channel interleaved CCM PFC EVAL board
IKW40N65WR5, IDW60C65D1 and 1ED44175 in high frequency PFC application



System design

Quantity	Ref Designator	Value	Description	Manufacturer	Manufacturer P/N
1	U6	ICE5QSAG	Quasi-Resonant PWM Controller	Infineon Technologies	ICE5QSAG
1	U7	SFH617A-3	Optocoupler, Phototransistor Output, High Reliability, 5300 VRMS, 110 ÅC Rated	Vishay	SFH617A-3
2	U11, U12	LM2903D	Dual differential comparators	Texas Instruments	LM2903D
5	X1, X3, X6, X7, X9	7460307	WP-BUTR Redcube Press Fit with Internal Thread and Two Rows Pin-Plate	Würth Elektronik	7460307
2	X2, X8	691311500102	Terminal Block, 2Pins, 5.08mm Pitch, Board to Cable	Würth Elektronik	691311500102
4	X4, X5	3513	Through Hole 3AG Snap In Fuse Clip	Conquer	CQ-205S
2	FAN1, FAN2	AFB0612EH-ABF00	Cooling fans	Delta	AFB0612EH-ABF00

3.4 Connector details

Table 4 Connectors

PIN	Label	Function
X1	Grid Line	AC input of PFC, connect to grid line
X3	Grid Neutral	AC input of PFC, connect to grid neutral
X6	Earth	Protective earth
X7	PFC DC output	Connect to load positive
X9	PFC Ground	Connect to load negative
X2	Auto test	For AC input auto test
X8	Auto test	For PFC output auto test

System performance

4 System performance

4.1 Efficiency and PFC measurements

All test conditions are based on a 25°C ambient temperature

For the efficiency test it is important to monitor the voltage directly on the input connector X2 and output connector X8.

All efficiency and PF are carried out with a “WT33E” Yokogawa power meter.

Figure 16 shows the overall efficiency of EVAL-PFC5KIKWWR5SYS including the aux supply for cooling fans at different input voltages between 180 V_{AC} and 264 V_{AC}. The efficiency curves show that WR5 IGBT can support customers to increase the PFC switching frequency with high efficiency, even frequencies up to 60 kHz.

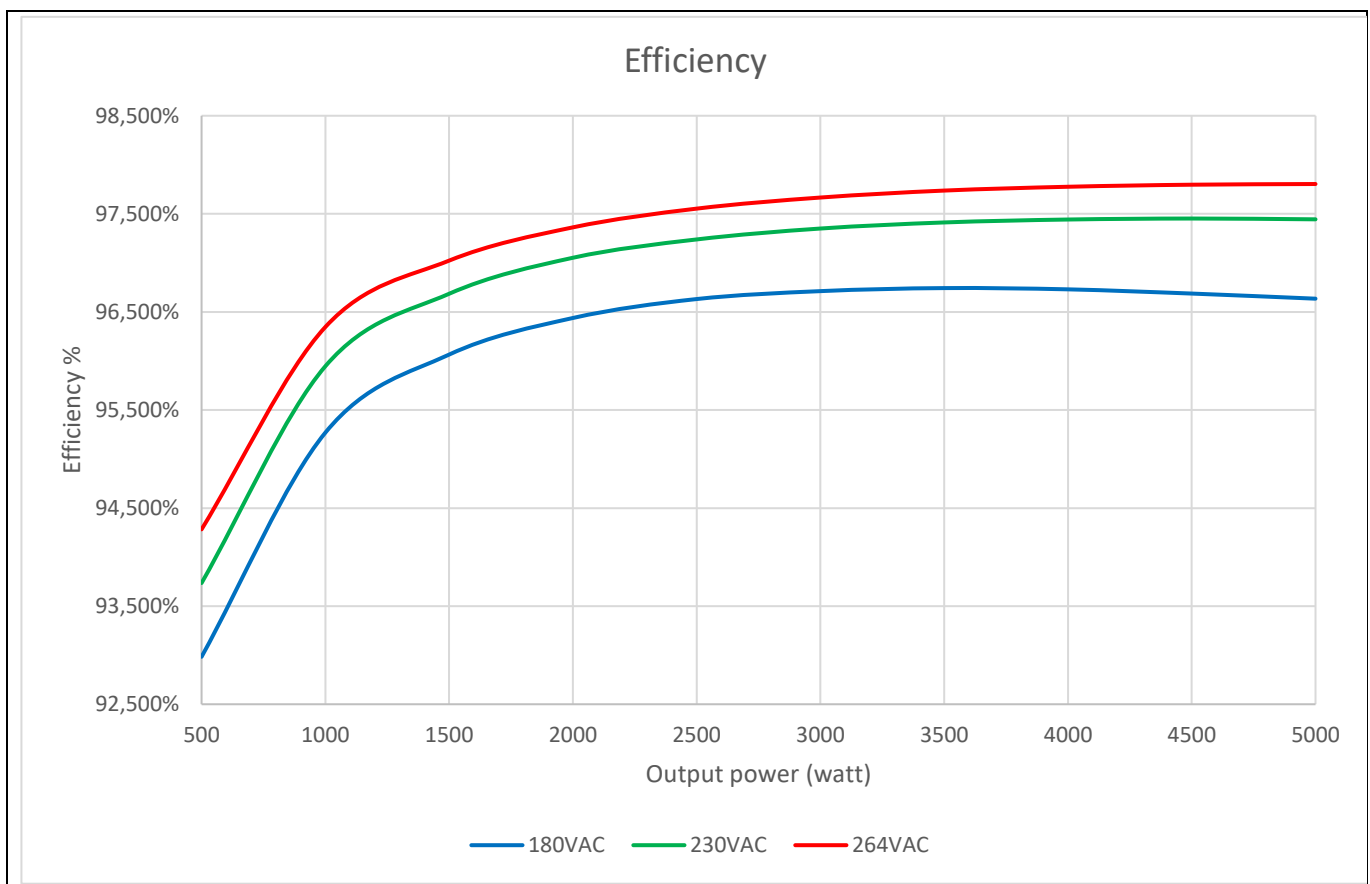

Figure 16 Efficiency of EVAL-PFC5KIKWWR5SYS

Figure 17 shows the power factor curve at different loads and different AC input voltages. As shown, even at light loads, the power factor is higher than 0.96. And an almost unity power factor is achieved, with values higher than 0.99 for loads above 30% of rated power.

System performance

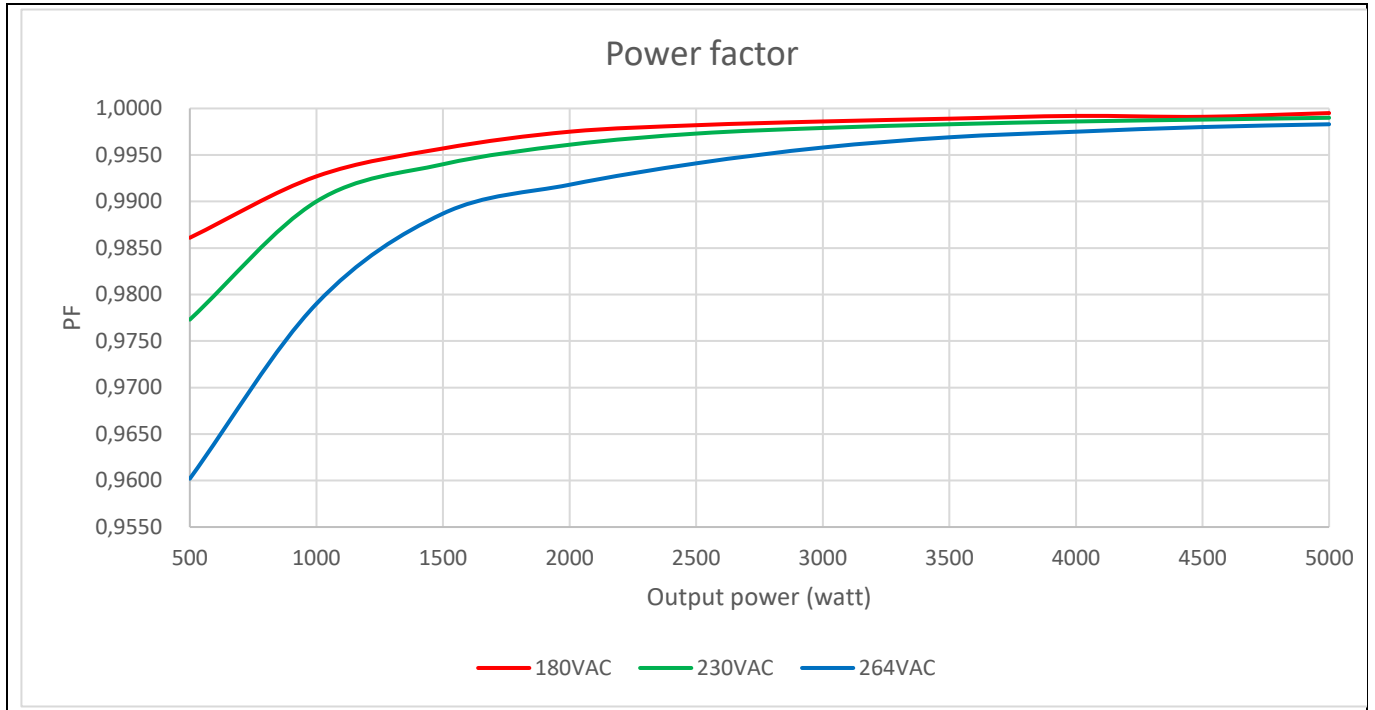

Figure 17 Power factor of EVAL-PFC5KIKWWR5SYS

4.2 Start-up behavior

Following connection to the grid, the auxiliary power supply starts, and the devices are supplied. During the output capacitor pre-charging phase, as seen in Figure 6, both channels are bypassed by the D20- an ultrafast high-voltage rectifier, and the inrush current is limited by two NTC resistors. Once output voltage reaches about $230 V_{DC}$, K1 relay turns on and two NTC are shorted, enabling the converter works with high efficiency.

The board is designed to start in both no load condition and full load condition. Figure 18 and Figure 19 show the converter full-load start-up waveforms at $V_{IN}=180 V_{AC}$ and $V_{IN}=264 V_{AC}$ respectively.

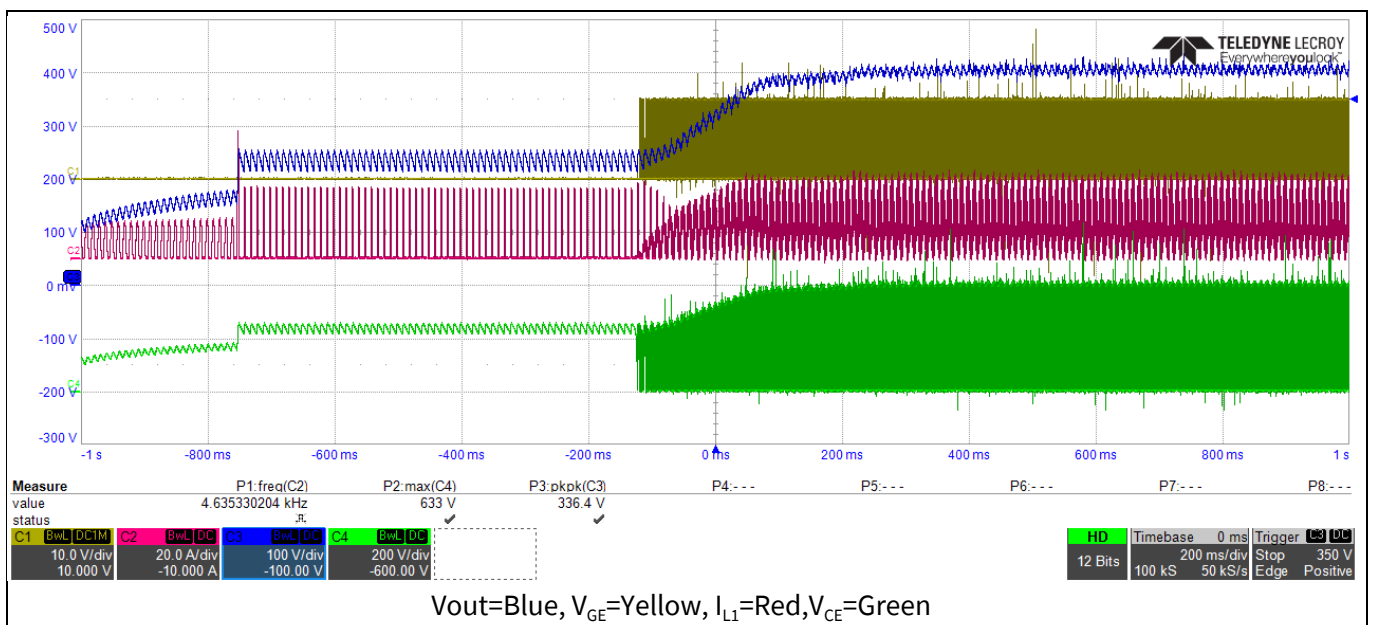

Figure 18 Full load start-up at $V_{IN}=180 V_{AC}$

System performance

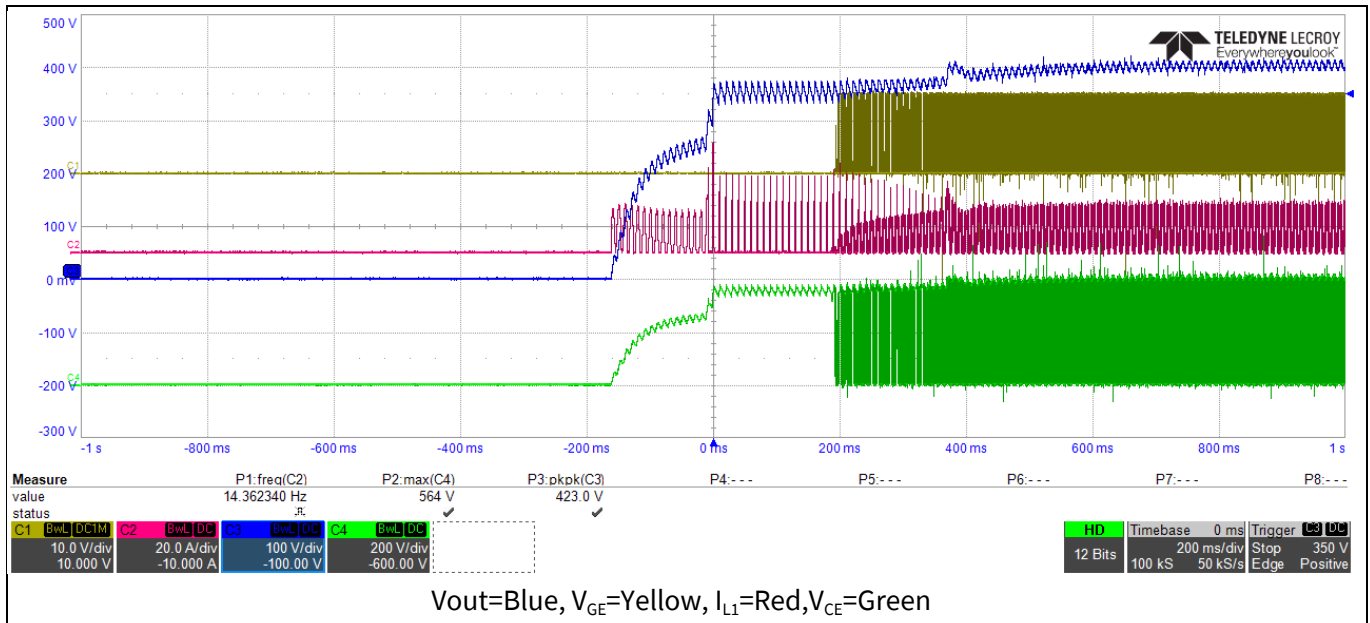

Figure 19 Full load start-up at V_{IN}=264 V_{AC}

4.3 Input current and inductor current cancellation

The next six waveforms show the input AC current and two inductor current waveforms of the converter at full load. The interleaving operation is clear and the two-channel currents are phase-shifted 180°.

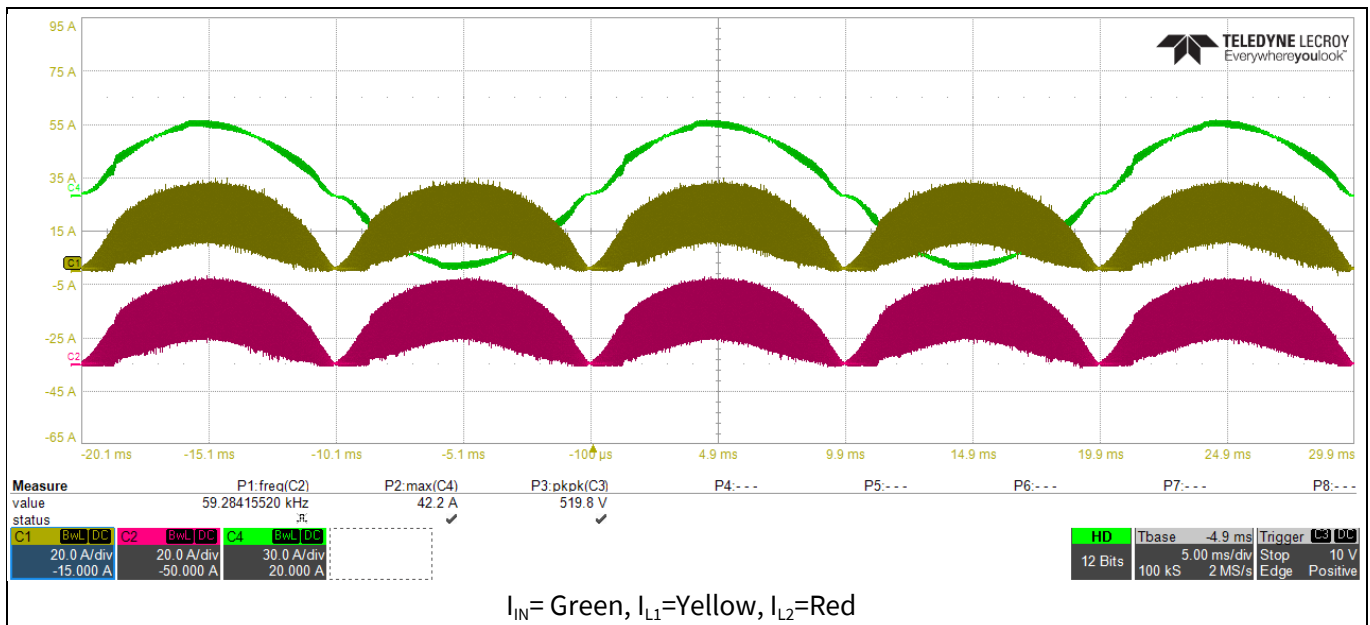

Figure 20 Interleaving operation at full load at V_{IN}=180 V_{AC}

5 kW two-channel interleaved CCM PFC EVAL board IKW40N65WR5, IDW60C65D1 and 1ED44175 in high frequency PFC application



System performance

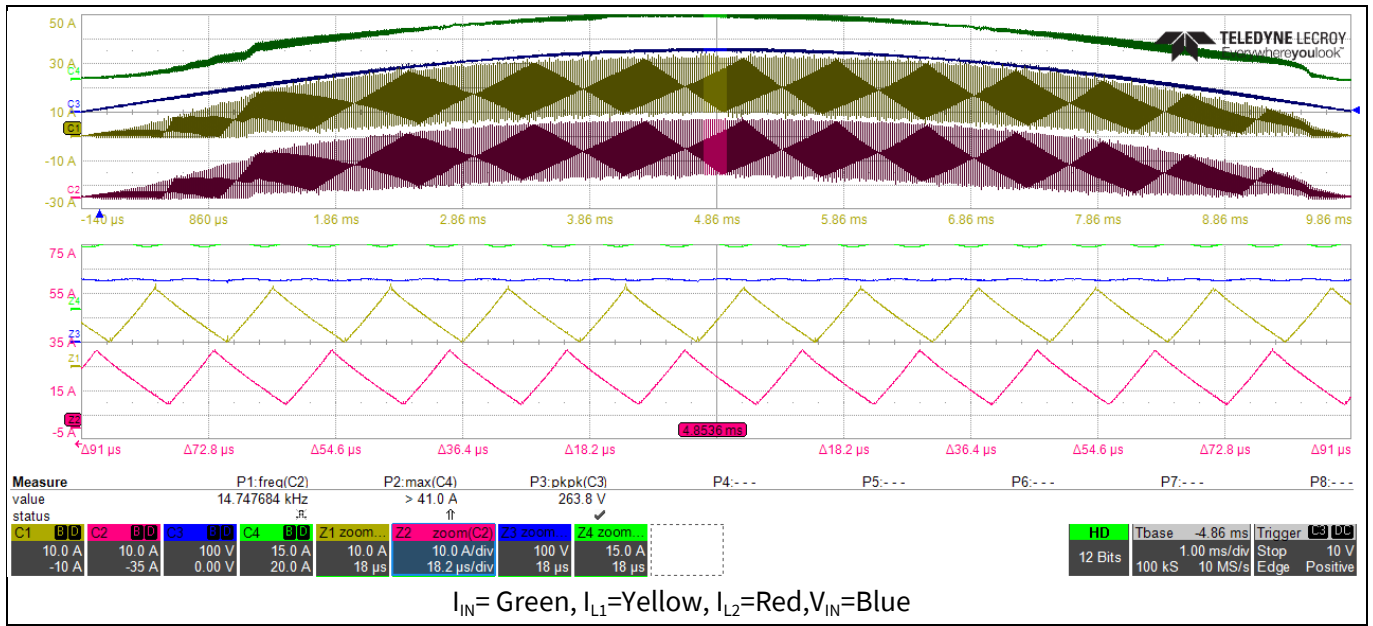

Figure 21 Detail view of interleaving operation at full load at $V_{IN}=180 V_{AC}$

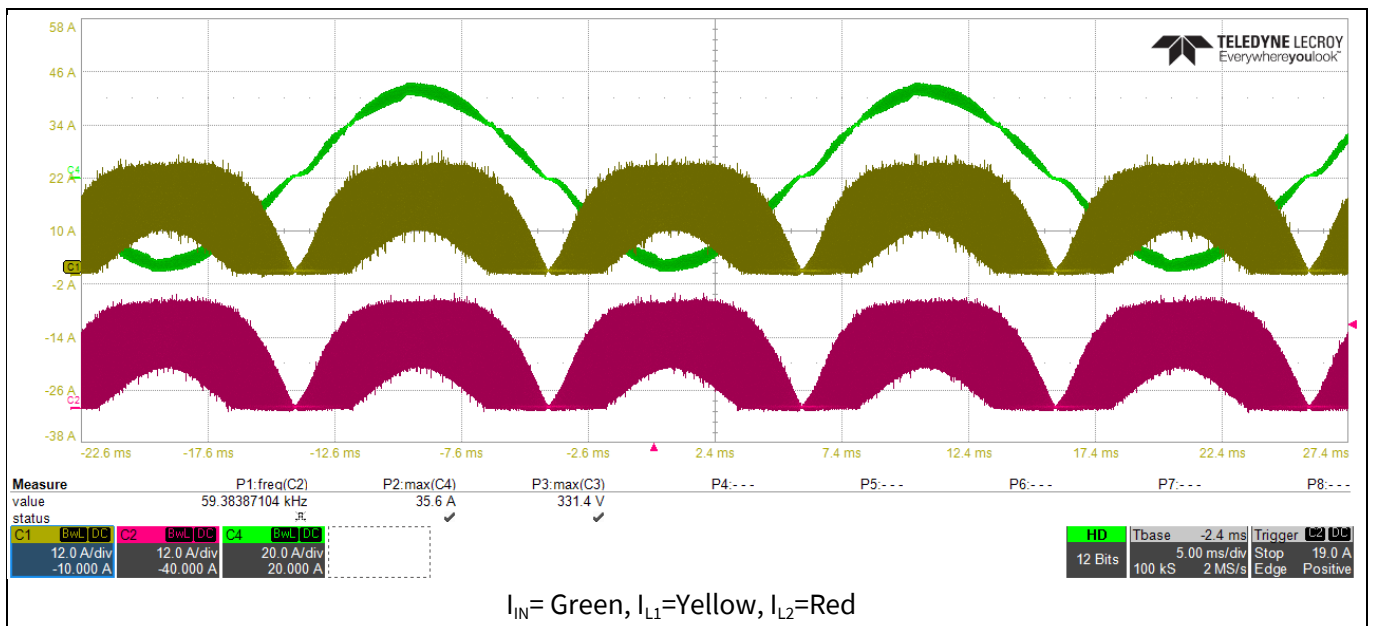

Figure 22 Interleaving operation at full load at $V_{IN}=230 V_{AC}$

5 kW two-channel interleaved CCM PFC EVAL board

IKW40N65WR5, IDW60C65D1 and 1ED44175 in high frequency PFC application



System performance

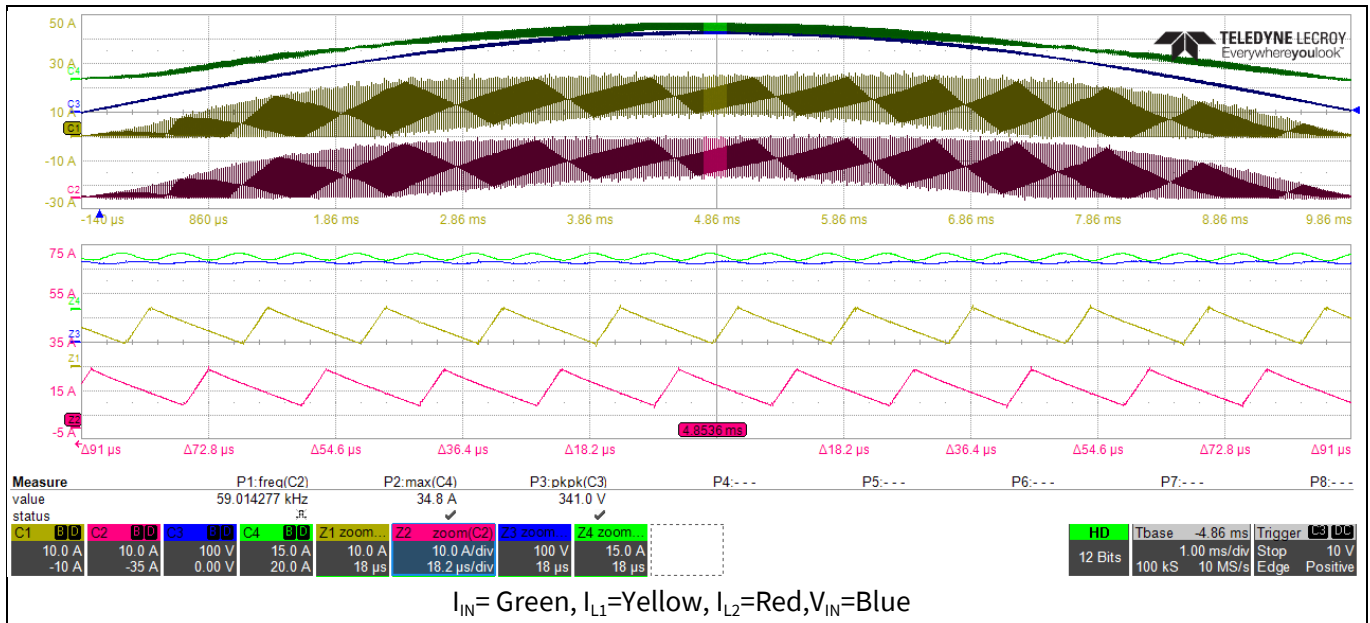

Figure 23 Detail view of interleaving operation at full load at $V_{IN}=230 V_{AC}$

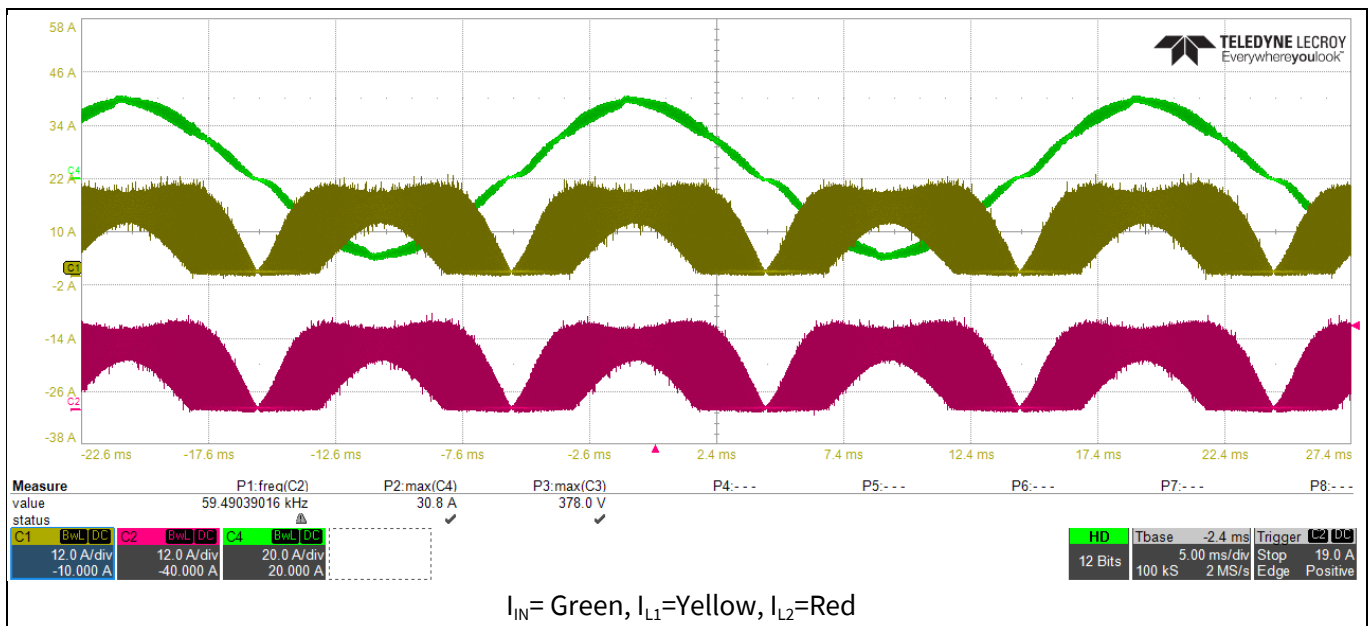

Figure 24 Interleaving operation at full load at $V_{IN}=264 V_{AC}$

5 kW two-channel interleaved CCM PFC EVAL board IKW40N65WR5, 1ED44175 and 1ED44175 in high frequency PFC application

System performance

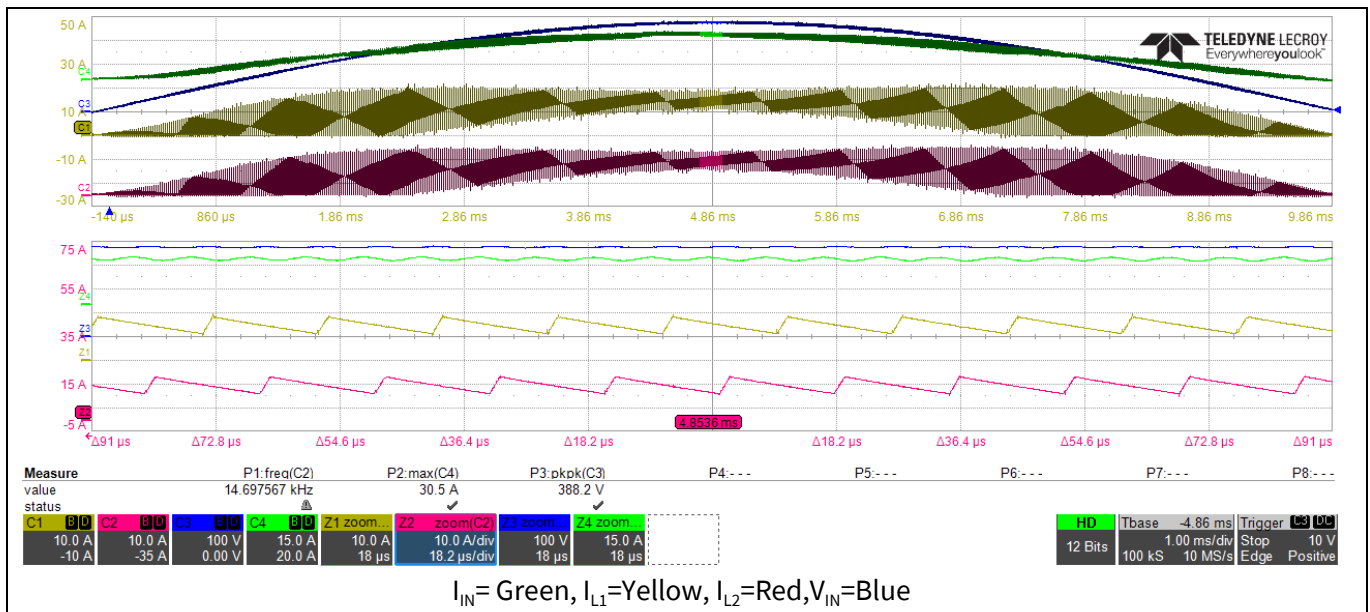

Figure 25 Detail view of interleaving operation at full load at $V_{IN}=264 V_{AC}$

4.4 Switching performance of IGBT at steady state

The design for this board is aimed at achieving high efficiency by using 650V TRENCHSTOP™ 5 WR5 IGBT IKW40N65WR5 as the main switch in a high-frequency interleaved PFC application. Compared to Infineon’s H3 IGBT, the WR5 IGBT has lower conduction and switching losses, enabling the MOSFET to be replaced by a WR5 IGBT in up to 100 kHz applications.

The following three waveforms show switching performances of IKW40N65WR5 with the low side gate driver 1ED44175. For considering the driver’s current capability, in this design, the turn-on gate resistance for each KW40N65WR5 is 5.1 Ω and turn-off resistance is 3 Ω. Smaller gate resistance for turn-on and turn-off helps to decrease turn-on and turn-off losses of the IGBT. However, during the design process, there is always a trade-off between achieving high efficiency and EMI. Customers need to make greater effort to reduce the noise by high dv/dt and high di/dt in high-frequency applications.

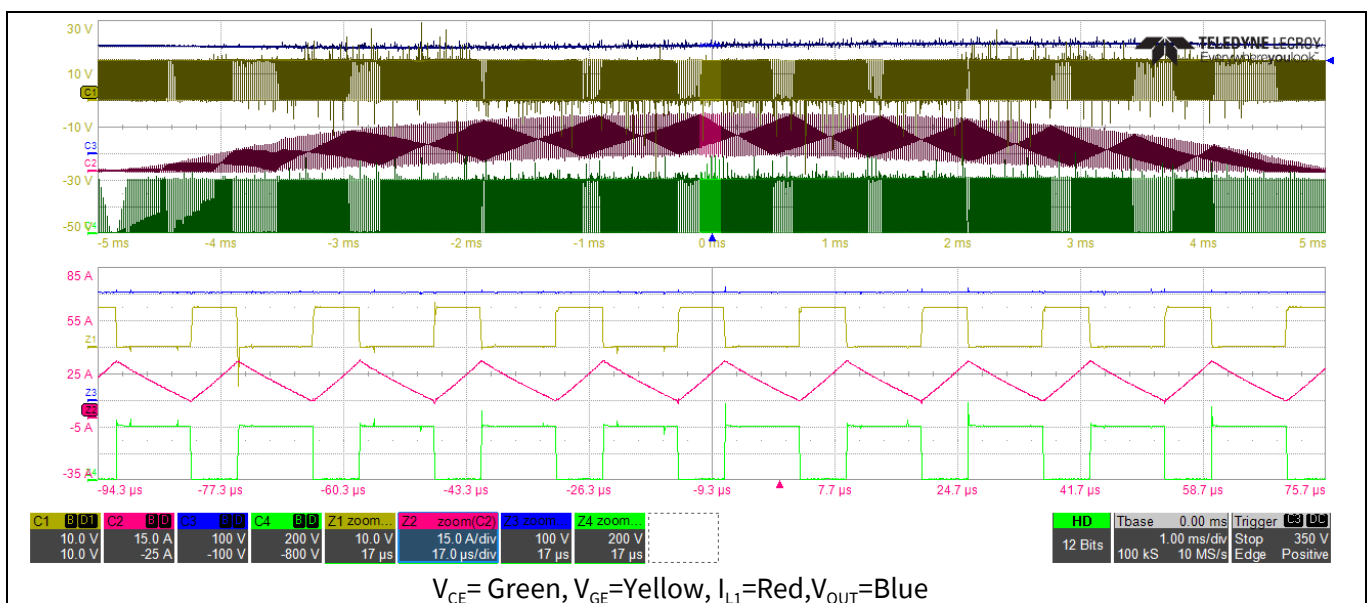

Figure 26 Switching waveforms of IGBT at $V_{IN}=180 V_{AC}$ at full load

System performance

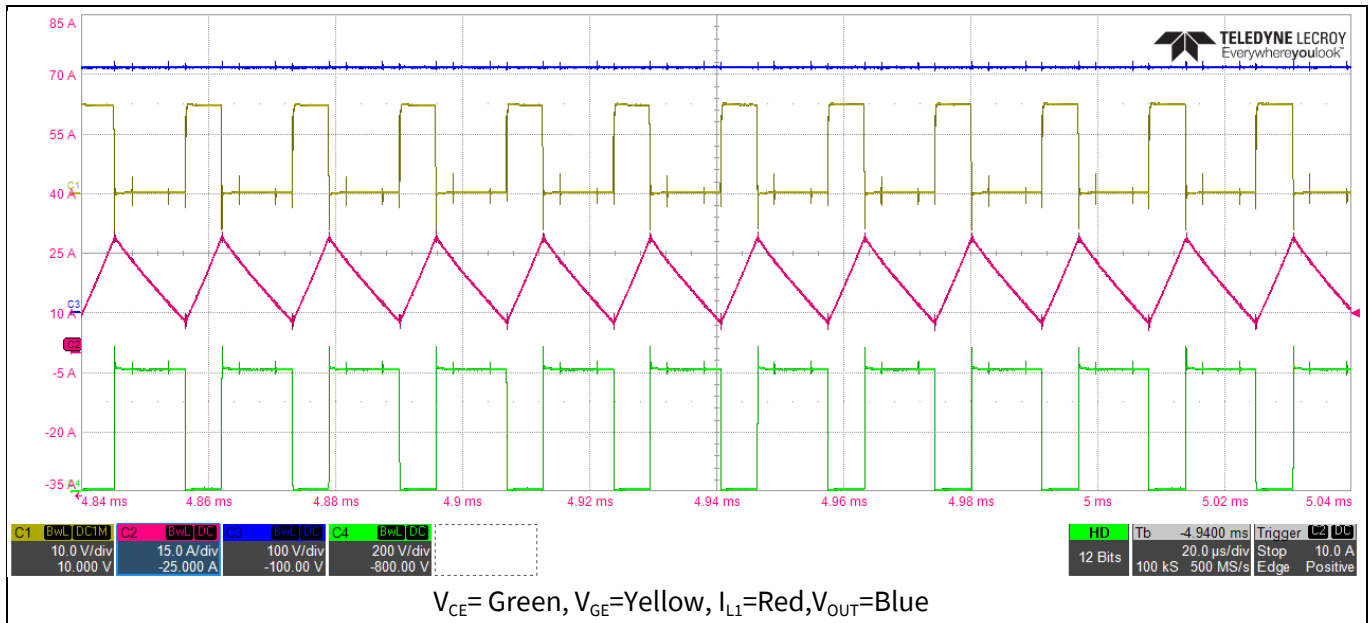

Figure 27 Switching waveforms of IGBT at $V_{IN}=200 V_{AC}$ at full load (continue current at high point of input voltage)

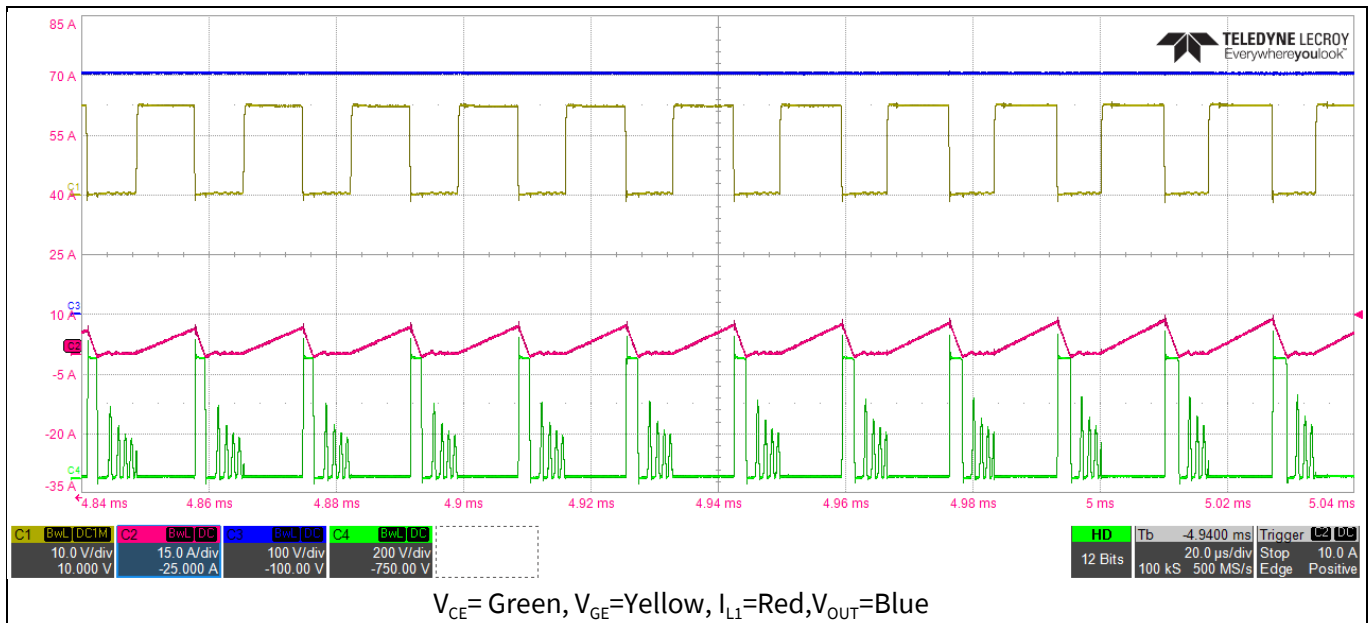

Figure 28 Switching waveforms of IGBT at $V_{IN}=200 V_{AC}$ at full load (discontinue current at low point of input voltage)

4.5 Output ripple voltage

Due to the limitation of the board size and cost considerations, there are only four output filter capacitors with a total of 2720 μF placed at the output stage. For the next three waveforms with full load at different input voltages, the permissible low-frequency ripple of the output voltage is smaller than 20 V, which meets design specifications as well.

5 kW two-channel interleaved CCM PFC EVAL board IKW40N65WR5, IDW60C65D1 and 1ED44175 in high frequency PFC application



System performance

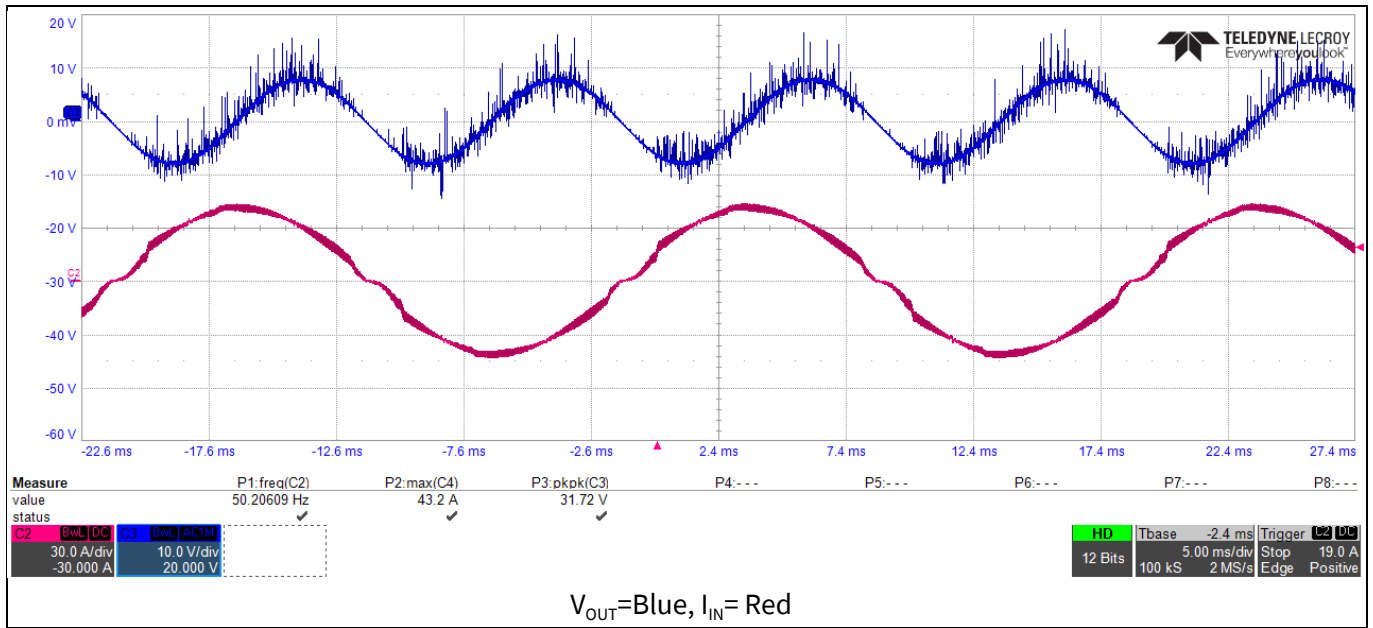

Figure 29 PFC output ripple voltage at $V_{IN}=180 V_{AC}$ at full load

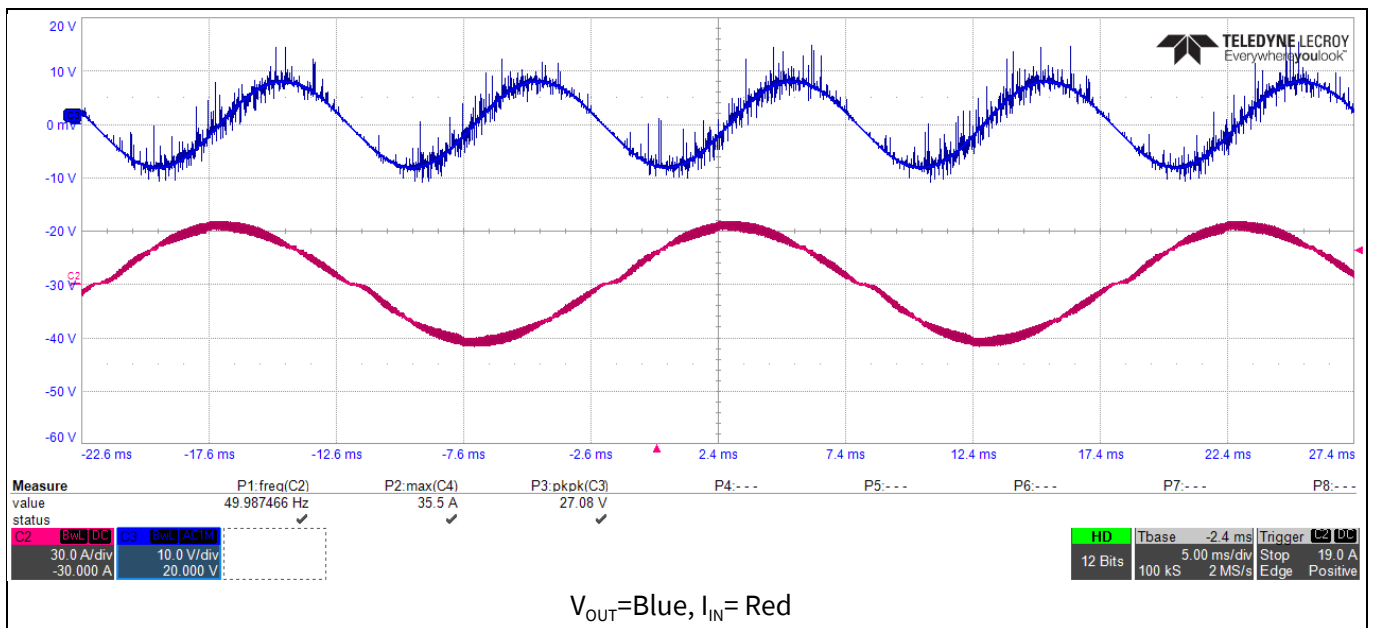

Figure 30 PFC output ripple voltage at $V_{IN}=230 V_{AC}$ at full load

System performance

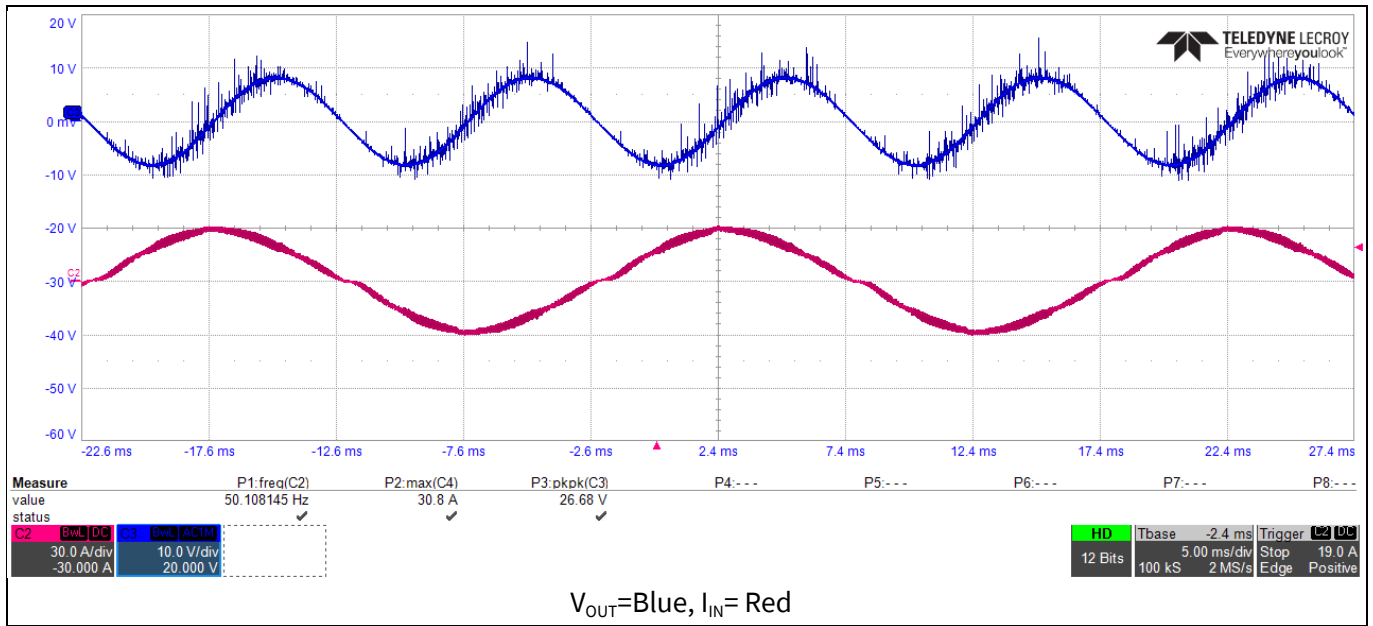

Figure 31 PFC output ripple voltage at V_{IN} =264 V_{AC} at full load

4.6 Input voltage and input current

The line current in the following figures are nearly perfect sinusoidal waves, in phase with the line voltage, while the output voltage is regulated at 400 V at full load.

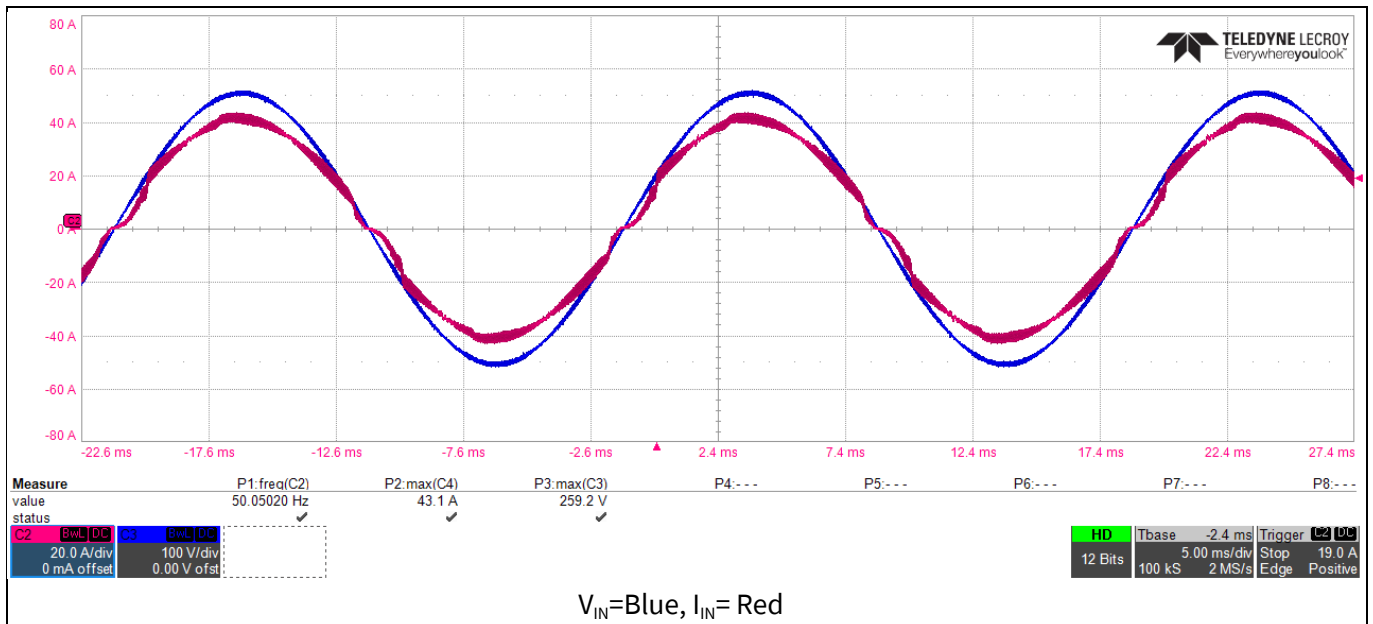

Figure 32 PFC input voltage and input current at V_{IN} =180 V_{AC} at full load

System performance

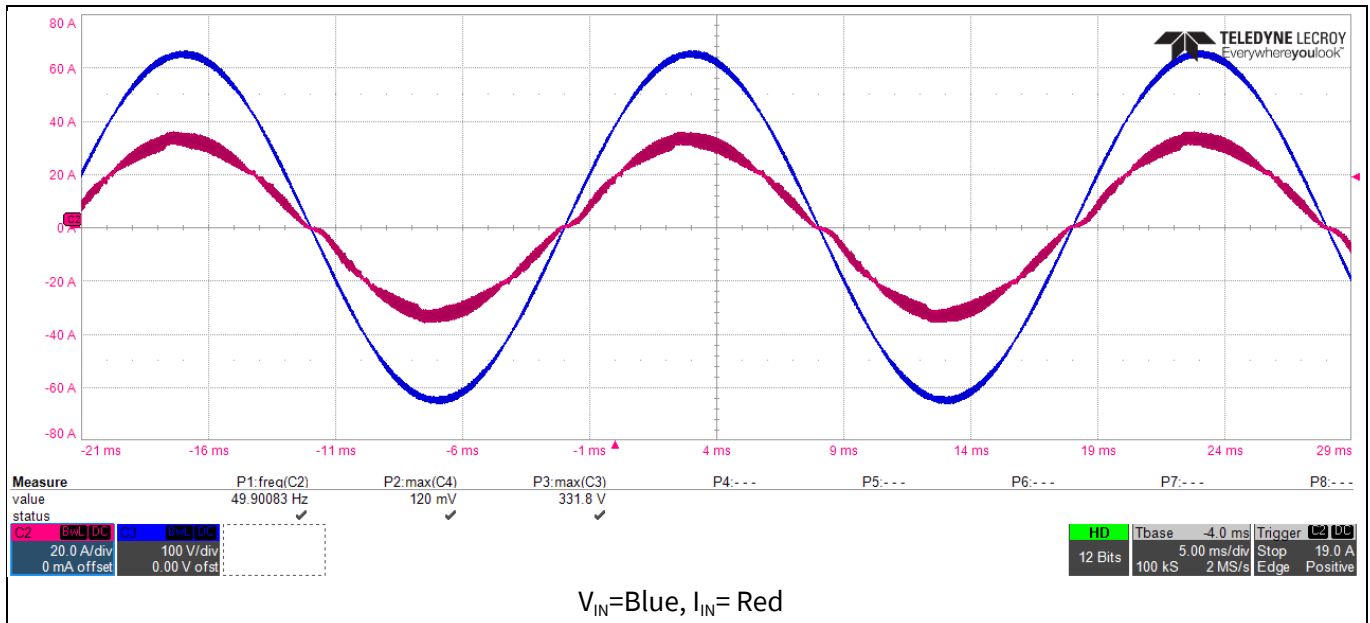

Figure 33 PFC input voltage and input current at $V_{IN}=230 V_{AC}$ at full load

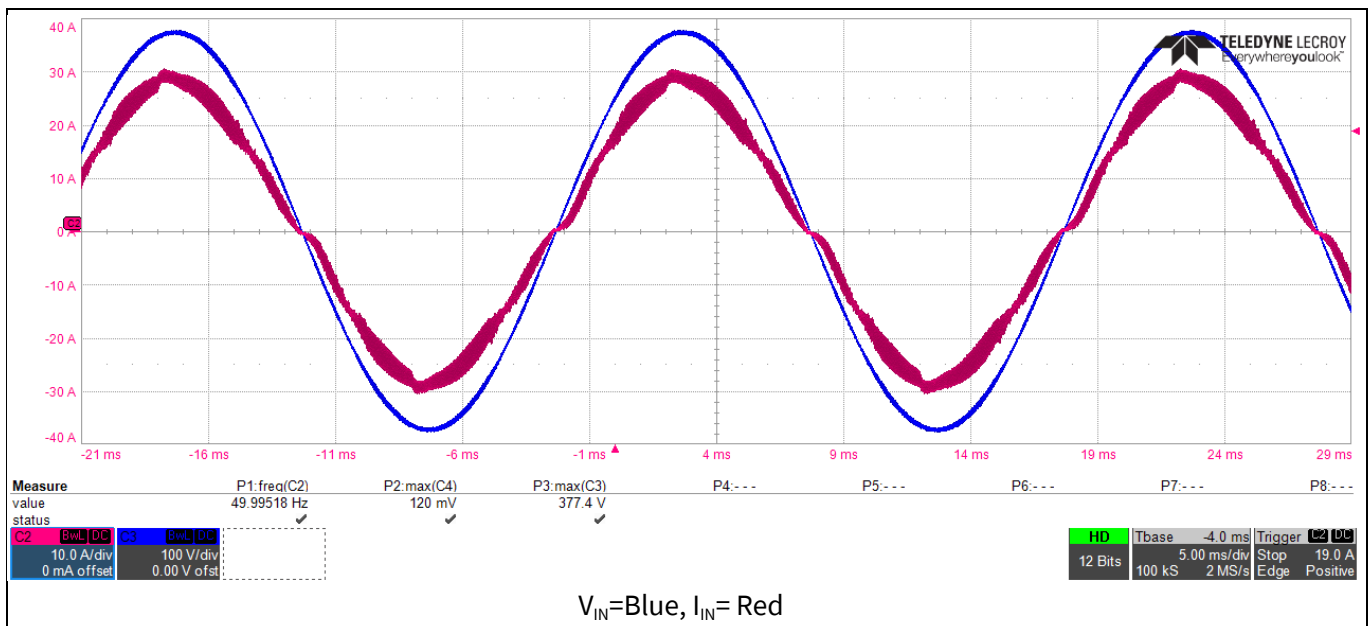

Figure 34 PFC input voltage and input current at $V_{IN}=264 V_{AC}$ at full load

4.7 Load step tests

Figure 35 and Figure 36 illustrate the response of the PFC converter during a load step from no load to full load with a voltage undershoot down to $352 V_{DC}$ and $360 V_{DC}$, respectively. After such an abrupt load demand, the PFC controller returns to regulation in around 60 ms.

5 kW two-channel interleaved CCM PFC EVAL board
 IKW40N65WR5, IDW60C65D1 and 1ED44175 in high frequency PFC application



System performance

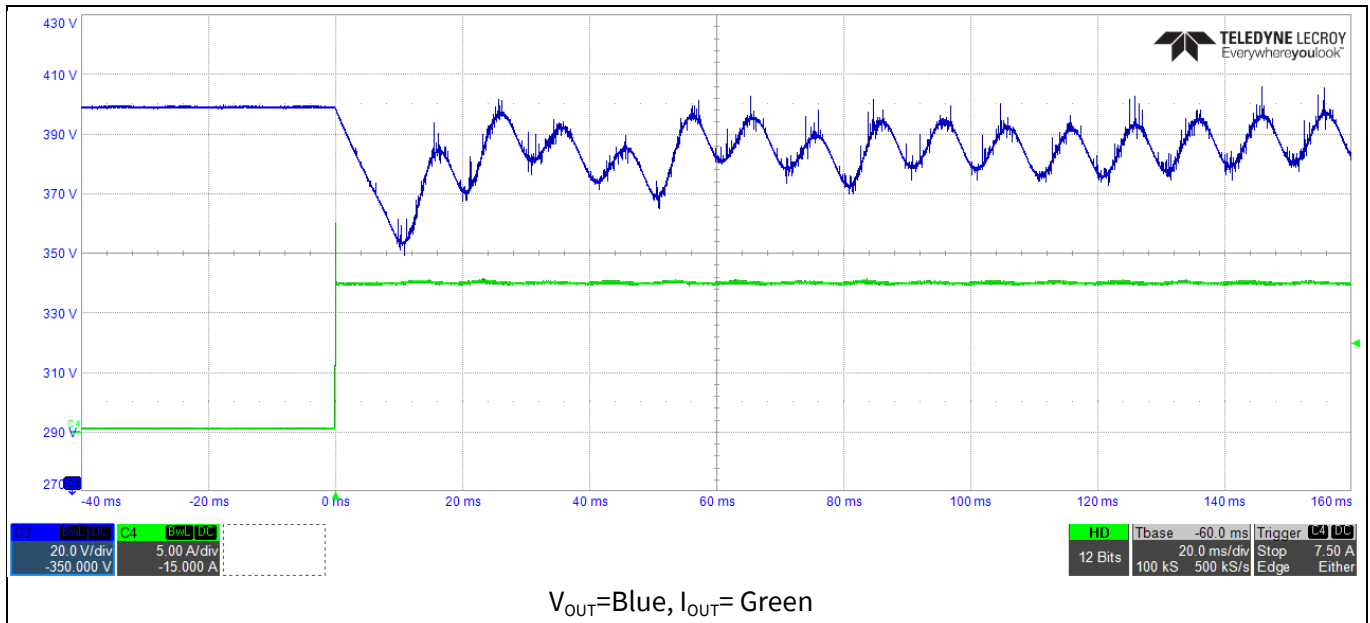

Figure 35 Load step :0%→100% at $V_{IN}=180 V_{AC}$

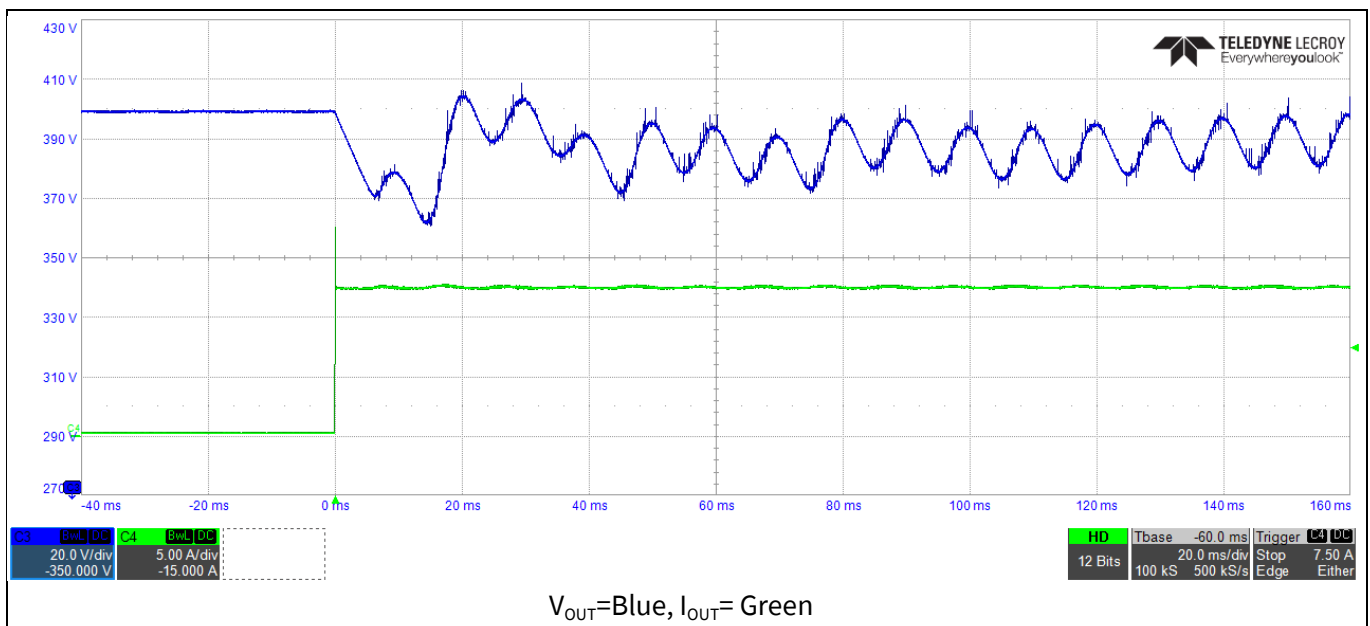

Figure 36 Load step :0%→100% at $V_{IN}=264 V_{AC}$

System performance

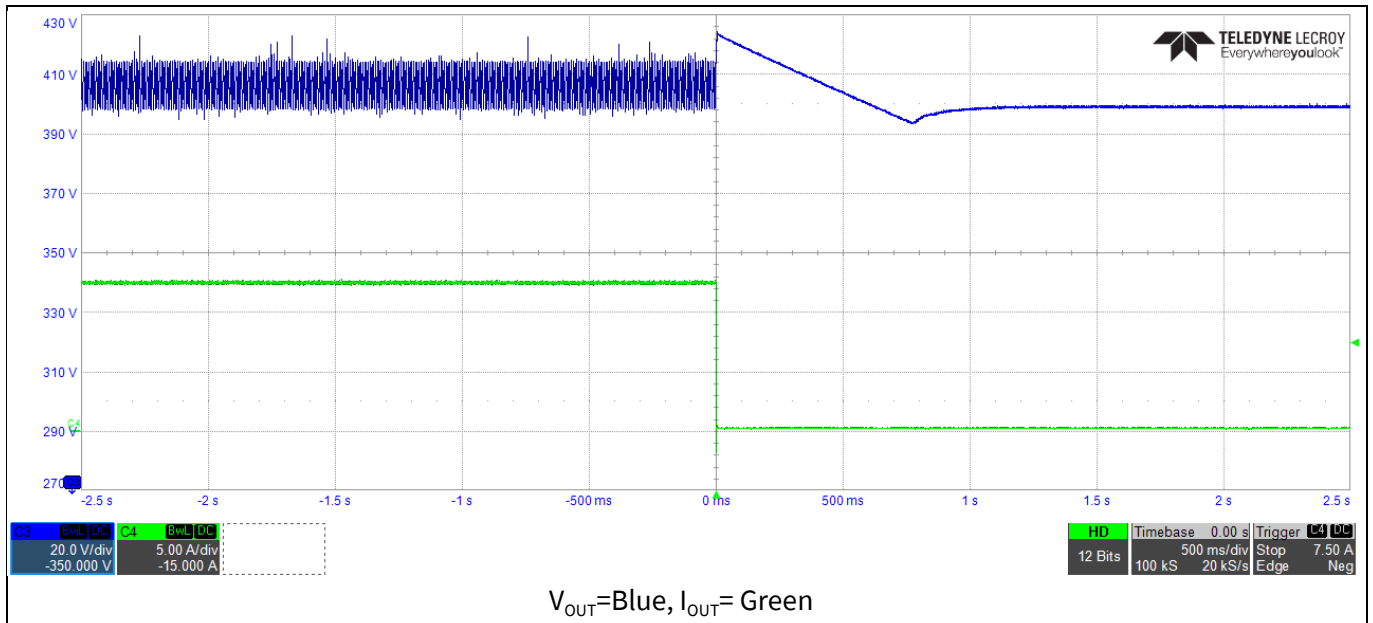

Figure 37 Load step :100%→0% at $V_{IN}=180 V_{AC}$

Figure 37 illustrates the response of the voltage control loop during a load step from 100% to 0% with a voltage overshoot up to 425 V. A similar response can be observed at $V_{IN} = 230 V_{AC}$ and $V_{IN} = 264 V_{AC}$.

4.8 Thermal measurements

The board shown in this document (EVAL-PFC5KIKWWR5SYS) is provided with an enclosure. The implemented thermal concept uses two low-power fans attached to two heatsinks, in which the power semiconductors dissipate their generated losses.

System performance

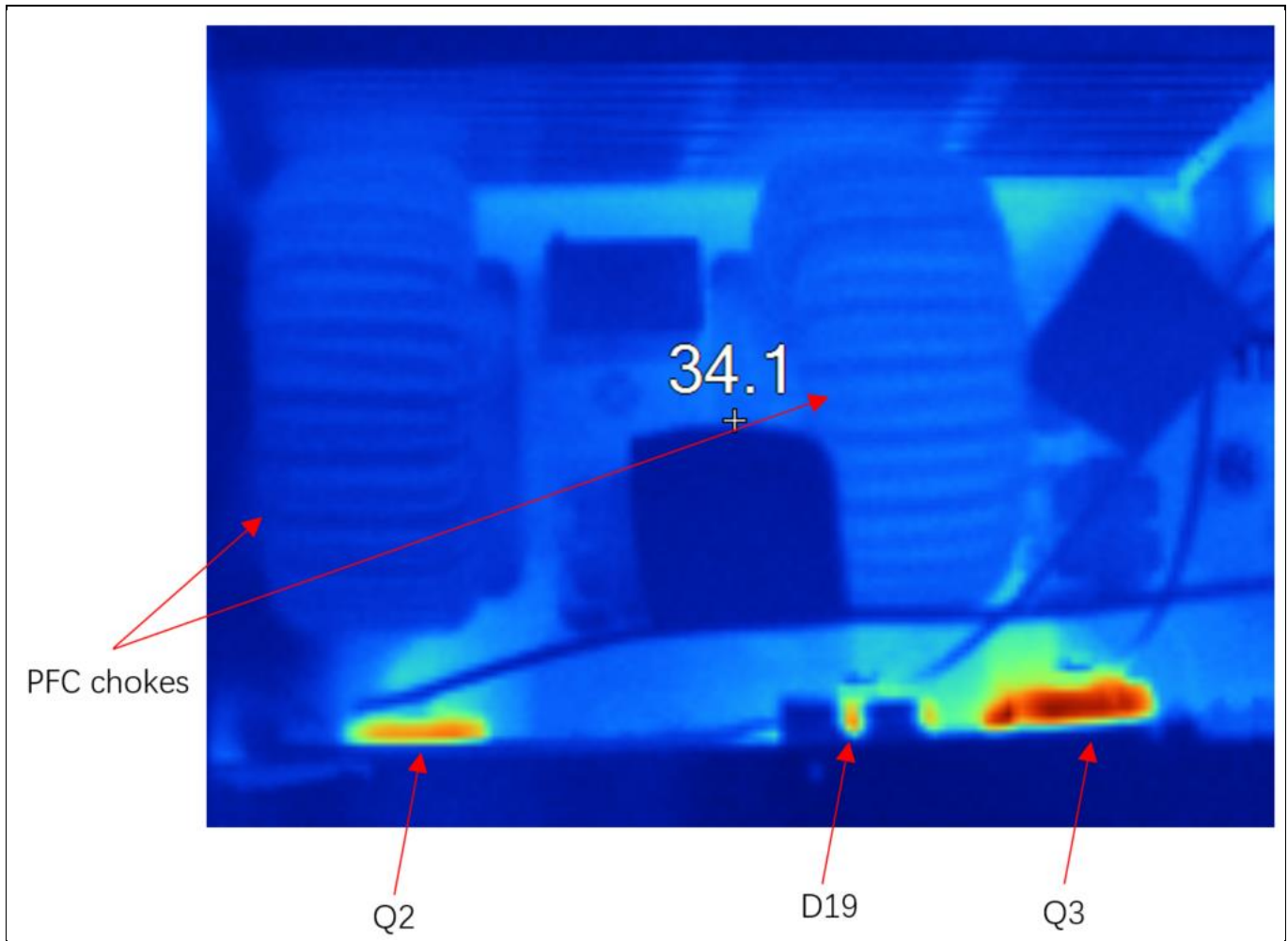

Figure 38 Thermal capture at room temperature at nominal input (180 V) and full load condition for PFC operation

Due to two powerful fans in an enclosed environment, the PFC chokes are not the hotspot of the board, as can be seen in Figure 38. One of WR5 IGBT (Q3) is the hottest power device on this board, which is far away from the cooling fans. According to temperature data collected by Keysight 34970A with thermal couples, as shown in Table 5, the highest temperature of the IGBT is 84.2°C at full load while input voltage is 180 V_{AC}. Fortunately, in floor-standing air-conditioner applications, its output power will be derated at low-input voltage, so, further temperature data at half load is also shown in Table 5, while input voltage is 180 V_{AC}, the highest temperature of IGBT is only 45.9°C.

Table 5 Temperature of power semiconductors

Devices	V _{IN} =230 V _{AC} , full load	V _{IN} =180 V _{AC} , full load	V _{IN} =180 V _{AC} , half load
Q2 (IKW40N65WR5)	51.7°C	67.8°C	39.8°C
D19 (IDW60C65D1)	61.6°C	74.2°C	40.3°C
Q3 (IKW40N65WR5)	62.1°C	84.2°C	45.9°C

Conclusions

5 Conclusions

This user guide describes the implementation of an analog-controlled, single-phase, two-channel interleaved PFC converter that operates in continuous conduction mode. This interleaved PFC converter achieves a peak efficiency of 97.804% by using an Infineon 650 V TRENCHSTOP™ 5 WR5 IGBT IKW40N65WR5 and rapid1 power silicon diode IDW60C65D1.

The EVAL-PFC5KIKWWR5SYS board has been tested using a programmable AC source and electronic load to demonstrate the key performance and behaviors in PFC operation.

Customers can also further increase the switching frequency to decrease the size and cost of the inductors, or extend the converter input voltage from 85 V_{AC} to 264V_{AC}. External parameter settings of resistors and capacitors of UCC28070 are also needed as an optimization to the new requirements.

6 References and appendices

6.1 Abbreviations and definitions

Table 6 Abbreviations

Abbreviation	Meaning
CE	Conformité Européenne
EMI	Electromagnetic interference
UL	Underwriters Laboratories
BOM	Bill of Material
QR	Quasi-resonant
PF	Power factor
POCO	A Chinese powder core manufacturer
NPH-L	A powder core material from POCO

6.2 References

- [1] Texas instruments, “UCC28070 300W Interleaved PFC Pre-regulator Design Review (Rev. B)”, Application Report, SLUA479B, August 2008.
- [2] Infineon Technologies, “Fifth-generation QR design guide for ICE5QSAG and ICE5QRXXXAX”, Application Report, DG_201609_PL83_026, September 2017.

6.3 Additional information

In the following links you can find more detailed information about the used devices from Infineon.

- TRENCHSTOP™ 5 WR5 IGBT [IKW40N65WR5](#)
- Low-side gate driver [1ED44175N01B](#)
- Rapid1 power silicon diode [IDW60C65D1](#)
- QR Flyback controller [ICE5QSBG](#) for auxiliary supply

Revision history

Revision history

Document version	Date of release	Description of changes
V1.0	March 5,2021	User guide-initial release

Trademarks

All referenced product or service names and trademarks are the property of their respective owners.

Edition 2021-03-05

Published by

Infineon Technologies AG

81726 Munich, Germany

© 2021 Infineon Technologies AG.

All Rights Reserved.

Do you have a question about this document?

Email: erratum@infineon.com

Document reference

UG-2021-06

For further information on the product, technology, delivery terms and conditions and prices please contact your nearest Infineon Technologies office (www.infineon.com).

WARNINGS

Due to technical requirements products may contain dangerous substances. For information on the types in question please contact your nearest Infineon Technologies office.

Except as otherwise explicitly approved by Infineon Technologies in a written document signed by authorized representatives of Infineon Technologies, Infineon Technologies' products may not be used in any applications where a failure of the product or any consequences of the use thereof can reasonably be expected to result in personal injury.