

**TOP VIEW**

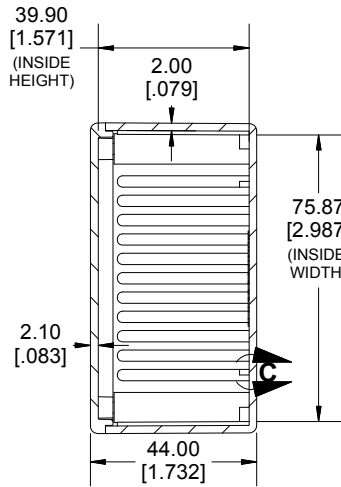

**SECTION A-A**

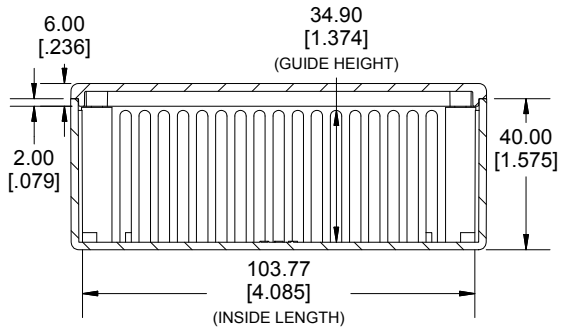
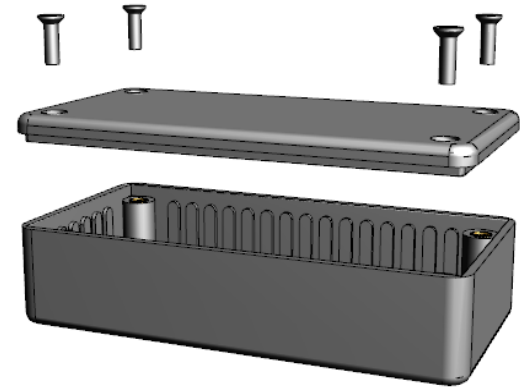

**SECTION B-B  
SIDE VIEW**

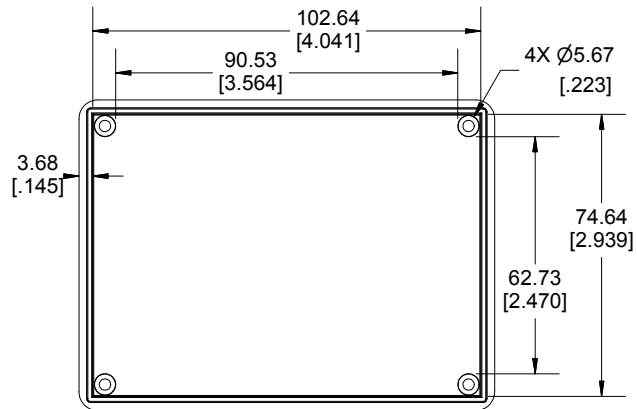
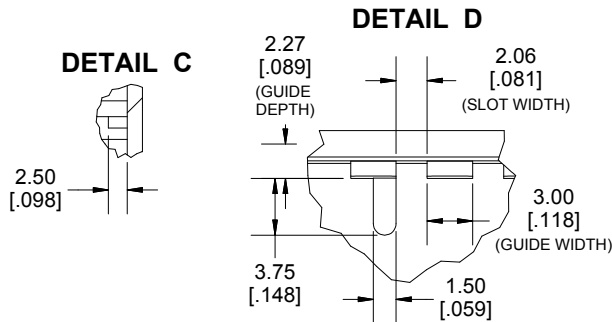

**INSIDE LID**

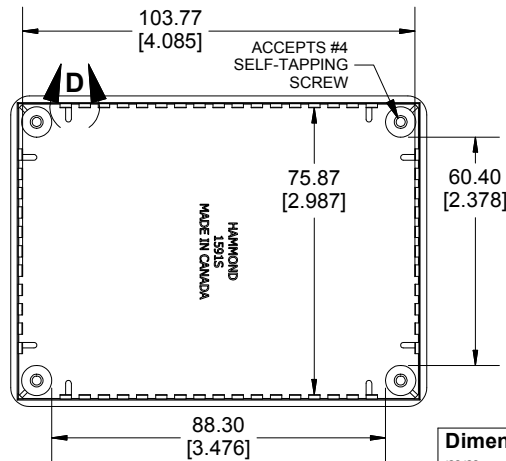

**INSIDE BOX**

Dimensions:  
mm  
[inches]

Enclosures can be Factory Modified ( Milling, Drilling, Printing etc.)  
Contact Factory [mjm@hammondmfg.com](mailto:mjm@hammondmfg.com) for quotes  
Solid models of this enclosure available in STEP or IGES.

<b>NOTE</b>	
Purchased assembly includes box, lid and 4 cover screws Enclosure made from GPABS.	
<b>Recommended Torque: 42-57 ozf.in (30-40 cN.m)</b>	
<b>PART NUMBERS</b>	
1591S Enclosure	
General Purpose ABS Black	1591SSBK
General Purpose ABS Grey	1591SSGY
Accessories	
Plated Cover screw	1591TS100 (Silver)
#4 X 1/2" (100Pkg) Self-Tapping	1591TS100BK (Black)
PC Board Card Adapters	1591Z6 (6Pkg)
	1591Z50 (50 Pkg)
	1591Z100 (100Pkg)
Nylon Belt / Pocket clip	1599CLIP (Black)
	1599CLIPGY (Grey)
Clear Lids - Flame Retardant Polycarbonate - Lid ONLY	1591SC

**HAMMOND  
MANUFACTURING®**

**1591SS**

[www.hammondmfg.com](http://www.hammondmfg.com)