



> Matrix 210™



Datalogic Automation S.r.l.
Via Lavino, 265
40050 - Monte S. Pietro
Bologna - Italy

Matrix 210™ Reference Manual

Ed.: 10/2014

© 2011 - 2014 Datalogic Automation S.r.l. ♦ ALL RIGHTS RESERVED. ♦ Protected to the fullest extent under U.S. and international laws. Copying, or altering of this document is prohibited without express written consent from Datalogic Automation S.r.l.

Datalogic and the Datalogic logo are registered trademarks of Datalogic S.p.A. in many countries, including the U.S.A. and the E.U.

Matrix 210, ID-NET, VisiSet and X-PRESS are trademarks of Datalogic Automation S.r.l. All other brand and product names mentioned herein are for identification purposes only and may be trademarks or registered trademarks of their respective owners.

Datalogic shall not be liable for technical or editorial errors or omissions contained herein, nor for incidental or consequential damages resulting from the use of this material.

CONTENTS

- REFERENCES vi**
 - Conventions vi
 - Reference Documentation vi
 - Support Through The Website..... vi
 - Patents..... vi

- COMPLIANCE..... vii**
 - EMC Compliance.....vii
 - Power Supply.....vii
 - CE Compliance.....vii
 - FCC Compliancevii
 - LED Safety.....vii

- HANDLING viii**

- GENERAL VIEW x**

- 1 RAPID CONFIGURATION 1**
 - Step 1 – Connect the System 1
 - Step 2 – Mount and Position the Reader 5
 - Step 3 – Aim the Reader 6
 - Step 4 – X-PRESS™ Configuration..... 7
 - Reset Reader to Factory Default (Optional) 8
 - Step 5 – Installing VisiSet™ Configuration Program 9
 - Step 6 – Configuration Using Setup Wizard 11
 - Step 7 – Test Mode 14
 - Advanced Reader Configuration..... 15

- 2 INTRODUCTION 16**
 - 2.1 Product Description 16
 - 2.2 Indicators and Keypad Button..... 19
 - 2.3 ID-NET™ 20
 - 2.3.1 How To Setup/Configure the Reader Network 21
 - 2.3.2 ID-NET™ Slave Management Through Master..... 23
 - 2.4 External Memory Backup and Restore Through VisiSet™ 24
 - 2.5 X-PRESS™ Human Machine Interface 29
 - 2.5.1 X-PRESS™ Functions..... 29
 - 2.5.2 Diagnostic Indication..... 31
 - 2.6 Model Description 32
 - 2.7 Accessories 33
 - 2.8 Application Examples 34
 - 2.8.1 Document Handling 34
 - 2.8.2 Deformed or Overprinted Code Reading 34
 - 2.8.3 Direct Part Marking 35
 - 2.8.4 Ink-Jet Printing Technology 35
 - 2.8.5 Laser Marking/Etching Technology 36
 - 2.9 External Lighting Systems 36

- 3 INSTALLATION 37**
 - 3.1 Package Contents 37
 - 3.2 Mechanical Dimensions..... 38

3.3	Mounting and Positioning Matrix 210™	40
4	CBX ELECTRICAL CONNECTIONS.....	42
4.1	Power Supply.....	43
4.2	Main Serial Interface.....	43
4.2.1	RS232 Interface.....	44
4.2.2	RS485 Full-Duplex Interface.....	45
4.2.3	RS485 Half-Duplex Interface	46
4.3	ID-NET™ Interface	48
4.3.1	ID-NET™ Cables	48
4.3.2	ID-NET™ Response Time	49
4.3.3	ID-NET™ Network Termination.....	53
4.4	Auxiliary RS232 Interface	53
4.5	Inputs.....	54
4.6	Outputs	57
4.7	External Lighting Systems	59
4.8	On-Board Ethernet Interface.....	60
4.9	User Interface - Host.....	60
5	TYPICAL LAYOUTS	61
5.1	Point-to-Point	61
5.1.1	Serial Host	61
5.1.2	Embedded (On-Board) Ethernet.....	62
5.1.3	TCP/IP Ethernet (BM2x0)	63
5.1.4	Fieldbus	64
5.2	Ethernet Networks	65
5.2.1	External Trigger Ethernet Host	65
5.3	ID-NET™ Synchronized Network	66
5.3.1	M/S Synchronized Serial Host.....	66
5.3.2	M/S Synchronized TCP/IP Host.....	68
5.3.3	M/S Synchronized Fieldbus Host.....	69
5.4	ID-NET™ Multidata Network	70
5.4.1	M/S Multidata Serial Host	70
5.4.2	M/S Multidata TCP/IP Host.....	71
5.4.3	M/S Multidata Fieldbus Host.....	72
5.5	Pass-Through	73
5.6	USB Connection	74
5.7	Other Layouts	75
6	READING FEATURES.....	76
6.1	Maximum Line Speed Calculation	77
7	SOFTWARE CONFIGURATION.....	79
7.1	VisiSet™ System Requirements.....	79
7.2	Installing VisiSet™	79
7.3	Startup	80
7.3.1	VisiSet™ Options.....	81
7.4	Configuration	83
7.4.1	Edit Reader Parameters	84
7.4.2	Send Configuration Options.....	86
7.4.3	Calibration.....	90
7.4.4	Multi Image Acquisition Settings.....	94
7.4.5	Run Time Self Tuning (RTST)	94
7.4.6	Region Of Interest Windowing.....	95
7.4.7	Direct Part Marking Applications.....	96

7.5	Image Capture and Decoding.....	101
7.6	Statistics	101
8	MAINTENANCE	102
8.1	Cleaning.....	102
9	TROUBLESHOOTING	103
9.1	General Guidelines	103
10	TECHNICAL FEATURES.....	106
A	ALTERNATIVE CONNECTIONS	108
	Power Com and I/O Connector.....	108
	On-Board Ethernet Connector	109
	ID-NET™ Network Termination.....	109
	Inputs.....	109
	Outputs	110
	User Interface – Serial Host.....	112
	GLOSSARY.....	113
	INDEX.....	116

REFERENCES

CONVENTIONS

This manual uses the following conventions:

"User" refers to anyone using a Matrix 210™ reader.

"Reader" refers to the Matrix 210™ reader.

"You" refers to the System Administrator or Technical Support person using this manual to install, configure, operate, maintain or troubleshoot a Matrix 210™ reader.

REFERENCE DOCUMENTATION

For further details refer to: the VisiSet™ Help On Line, Matrix Reading Methods, Matrix Host Mode Programming, Matrix SW Parameter Guide, Matrix Code Quality Verifier Solution provided as supplementary documentation on the VisiSet™ mini-DVD (downloaded ISO file or mini-DVD accessory).

SUPPORT THROUGH THE WEBSITE

Datalogic provides several services as well as technical support through its website. Log on to www.datalogic.com and click on the **Industrial Automation** [links](#) for further information:

- **PRODUCTS – FIXED INDUSTRIAL BARCODE READERS**

Select your product from the links on the **Fixed Industrial Barcode Readers** page. The product page describes specific Info, Features, Applications, Models, Accessories, and Downloads including documentation, software drivers, and the VisiSet™ utility program, which allows device configuration using a PC through Serial and Ethernet interfaces.

- **SUPPORT & SERVICES - INDUSTRIAL AUTOMATION**

Several links from the **Industrial Automation** list take you to additional services such as: Service Program which contains Maintenance Agreements and Warranty Extensions; Repair Centers; On-Line RMA Return Material Authorizations; Technical Support through email or phone, Downloads for additional downloads.

PATENTS

See www.patents.datalogic.com for patent list.

This product may be covered by one or more of the following patents:

Utility patents: EP0996284B1, EP0999514B1, EP1014292B1, EP1128315B1, EP1396811B1, EP1413971B1, EP1804089B1, EP2315156B1, JP4435343B2, JP4571258B2, JP5192390B2, US6512218, US6616039, US6808114, US6997385, US7053954, US7387246, US8058600, US8113430, US8368000, ZL200680050007.8

COMPLIANCE

For installation, use and maintenance it is not necessary to open the reader.

Only connect Ethernet and dataport connections to a network which has routing only within the plant or building and no routing outside the plant or building.

EMC COMPLIANCE

In order to meet the EMC requirements:

- connect reader chassis to the plant earth ground by means of a flat copper braid shorter than 100 mm
- connect pin "Earth" of the CBX connection box to a good Earth Ground

POWER SUPPLY

ATTENTION: READ THIS INFORMATION BEFORE INSTALLING THE PRODUCT

This product is intended to be installed by Qualified Personnel only.

This product is intended to be connected to a UL Listed Computer (LPS or "Class 2") which supplies power directly to the reader or a UL Listed Direct Plug-in Power Unit (rated 10 to 30 V, minimum 500 mA) marked LPS or "Class 2".

CE COMPLIANCE

Warning: This is a Class A product. In a domestic environment this product may cause radio interference in which case the user may be required to take adequate measures.

FCC COMPLIANCE

Modifications or changes to this equipment without the expressed written approval of Datalogic could void the authority to use the equipment.

This device complies with PART 15 of the FCC Rules. Operation is subject to the following two conditions: (1) This device may not cause harmful interference, and (2) this device must accept any interference received, including interference which may cause undesired operation.

This equipment has been tested and found to comply with the limits for a Class A digital device, pursuant to part 15 of the FCC Rules. These limits are designed to provide reasonable protection against harmful interference when the equipment is operated in a commercial environment. This equipment generates, uses, and can radiate radio frequency energy and, if not installed and used in accordance with the instruction manual, may cause harmful interference to radio communications. Operation of this equipment in a residential area is likely to cause harmful interference in which case the user will be required to correct the interference at his own expense.

LED SAFETY

LED emission according to EN 62471

HANDLING

The Matrix 210™ is designed to be used in an industrial environment and is built to withstand vibration and shock when correctly installed, however it is also a precision product and therefore before and during installation it must be handled correctly to avoid damage.

- avoid that the readers are dropped (exceeding shock limits).



- do not fine tune the positioning by striking the reader or bracket.

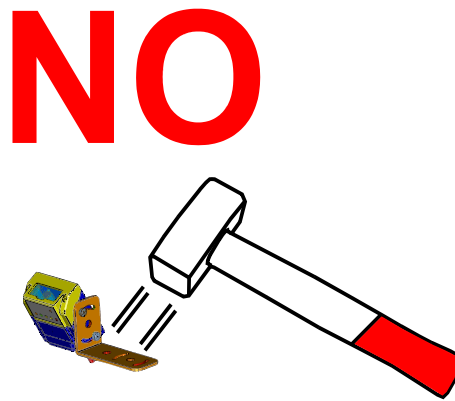

- do not weld the reader into position which can cause electrostatic, heat or reading window damage.

NO

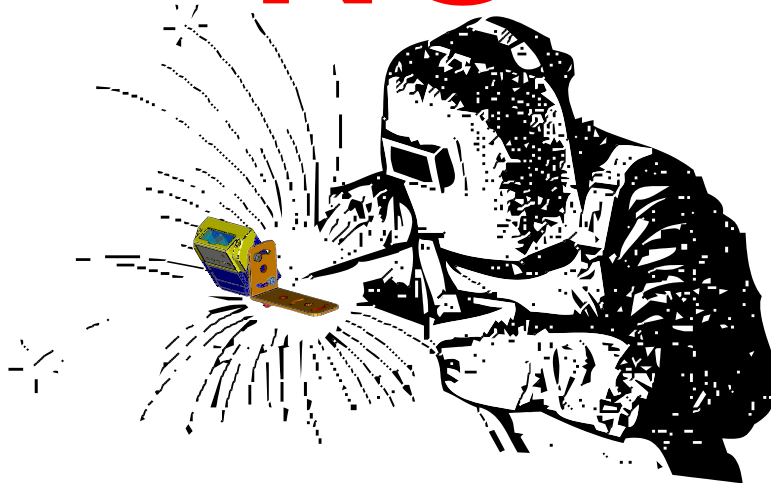

- do not spray paint near the reader which can cause reading window damage.

NO



GENERAL VIEW

Matrix 210™

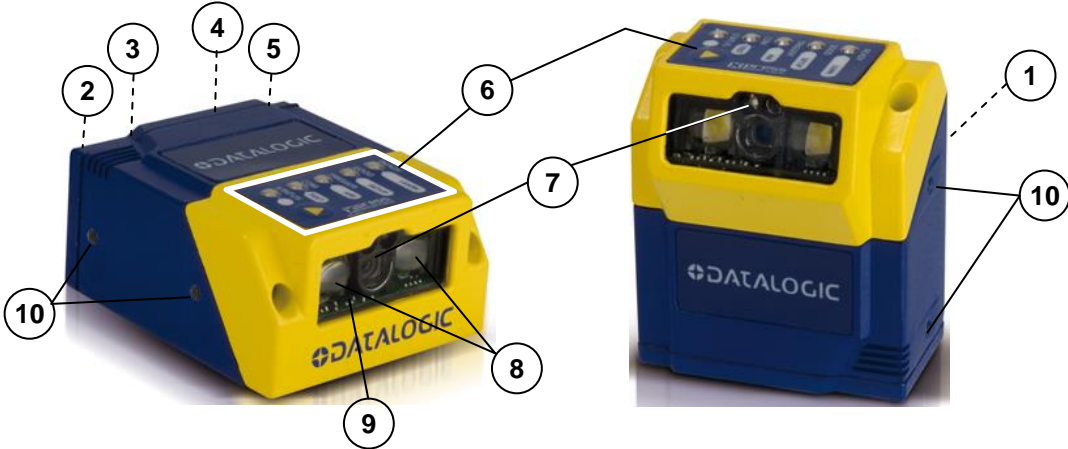

Figure A

- 1 Device Class Labels
- 2 Power On LED
- 3 Power - Serial - I/O Cable Connector
- 4 Ethernet Connector
- 5 Ethernet Connection LED (for Ethernet Models)
- 6 HMI X-PRESS™ Interface
- 7 Reading Window
- 8 Internal Illuminator
- 9 Good Read LED Spot (green)
- 10 Mounting Holes (4)

1 RAPID CONFIGURATION

STEP 1 – CONNECT THE SYSTEM

25-Pin Models

To connect the system in a Stand Alone configuration, you need the hardware indicated in Figure 1. In this layout the data is transmitted to the Host on the main serial interface. Data can also be transmitted on the RS232 auxiliary interface independently from the main interface selection.

When One Shot or Phase Mode Operating mode is used, the reader is activated by an External Trigger (photoelectric sensor) when the object enters its reading zone.

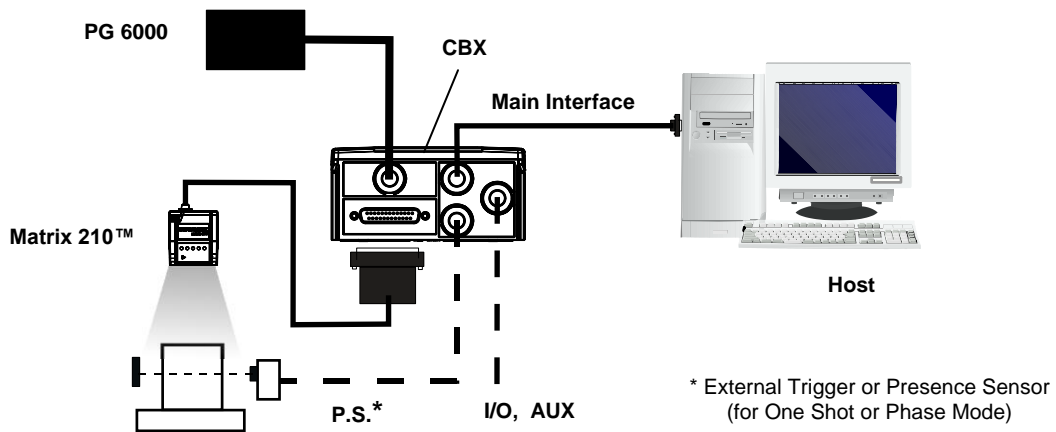

Figure 1 – Matrix 210™ in Stand Alone Layout

CBX100/CBX500 Pinout for Matrix 210™ 25-Pin Models

The table below gives the pinout of the CBX100/CBX500 terminal block connectors. Use this pinout when the Matrix 210™ reader is connected by means of the CBX100/CBX500:

CBX100/500 Terminal Block Connectors			
Input Power		Outputs	
Vdc	Power Supply Input Voltage +	+V	Power Source - Outputs
GND	Power Supply Input Voltage -	-V	Power Reference - Outputs
Earth	Protection Earth Ground	O1+	Output 1 +
		O1-	Output 1 -
		O2+	Output 2 +
		O2-	Output 2 -
Inputs		Auxiliary Interface	
+V	Power Source – External Trigger	TX	Auxiliary Interface TX
I1A	External Trigger A (polarity insensitive)	RX	Auxiliary Interface RX
I1B	External Trigger B (polarity insensitive)	SGND	Auxiliary Interface Reference
-V	Power Reference – External Trigger	ID-NET™	
+V	Power Source – Inputs	REF	Network Reference
I2A	Input 2 A (polarity insensitive)	ID+	ID-NET™ network +
I2B	Input 2 B (polarity insensitive)	ID-	ID-NET™ network -
-V	Power Reference – Inputs		
Shield			
Shield	Network Cable Shield		
Main Interface			
	RS232	RS485 Full-Duplex	RS485 Half-Duplex
	TX	TX+	RTX+
	RTS	TX-	RTX-
	RX	*RX+	
	CTS	*RX-	
	SGND	SGND	SGND

* Do not leave floating, see par. 4.2.2 for connection details.



CAUTION: Do not connect GND, SGND and REF to different (external) ground references. GND, SGND and REF are internally connected through filtering circuitry which can be permanently damaged if subjected to voltage drops over 0.8 Vdc.

USB Models



NOTE: Before connecting the reader to the USB Port, Install the USB Virtual COM Port Driver from the VisiSet™ mini-DVD (downloaded ISO file or mini-DVD accessory) in the Support Files\Software Utilities\USB Virtual COM Port Drivers directory.

The USB Virtual COM Port Driver allows sending serial data using the Matrix 210™ USB port. A different virtual COM Port will be assigned to each connected reader.

Installing the USB Virtual COM port drivers:

1. Double-click on the following file to launch the USB Virtual COM Port Driver Installer.

Windows XP/Vista/7 (x32) = "DPInst.exe" Windows Vista/7 (x64) = "DPInstx64.exe"

For other operating systems see the readme.txt in the Support Files\Software Utilities\USB Virtual COM Port Drivers directory. For updated drivers or more details go to ftdichip.com/Drivers/VCP.htm.

Configuring the USB Virtual COM port:

Connect the Matrix 210™ USB reader to your PC; a new virtual COM port is associated with the reader. Follow these steps to configure the associated COM Port:

2. Right-click on "My Computer" in the Windows "Start" menu and select "Properties".
3. Select the "Hardware" tab in the System Properties dialog and click the "Device Manager" button.
4. Expand the "Ports (COM & LPT)" item on the "Device Manager" menu. Right-click on "USB Serial Port" and select "Properties".
5. Select the "Port Settings" tab in the "Properties" dialog and click the "Advanced" button.

6. From the "Advanced Settings for COMx" dialog:

- Expand the "COM Port Number" menu and select a new COM Port number if desired (optional).
- Set the "BM Options" -> "Latency Timer" (msec) parameter to 1.

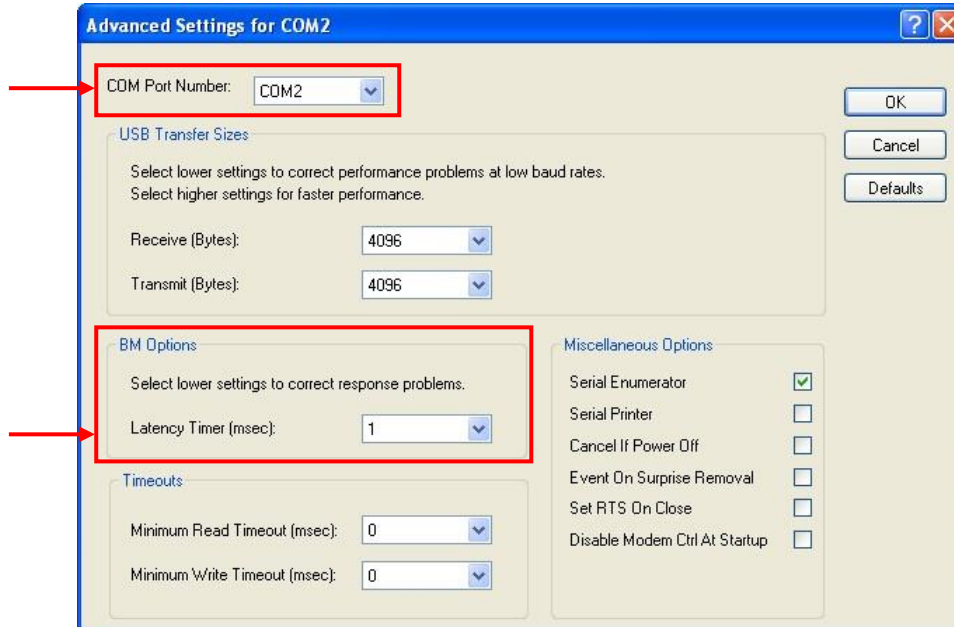

You are now ready to use the new COM Port.

Matrix 210™ USB models can be connected in a Point-to-Point layout to a local host through their USB cable. No external power supply is necessary.

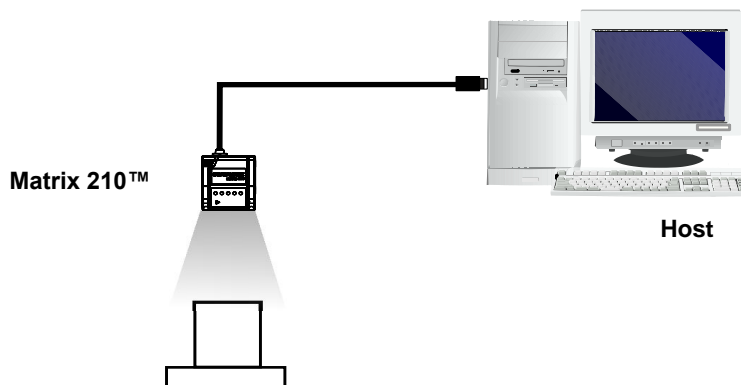

Figure 2 – Matrix 210™ USB Model in a Point-to-Point Layout

STEP 2 – MOUNT AND POSITION THE READER

1. To mount the Matrix 210™, use the mounting brackets to obtain the most suitable position for the reader. Two of the most common mounting configurations are shown in the figures below. Other mounting solutions are provided in par. 3.3.

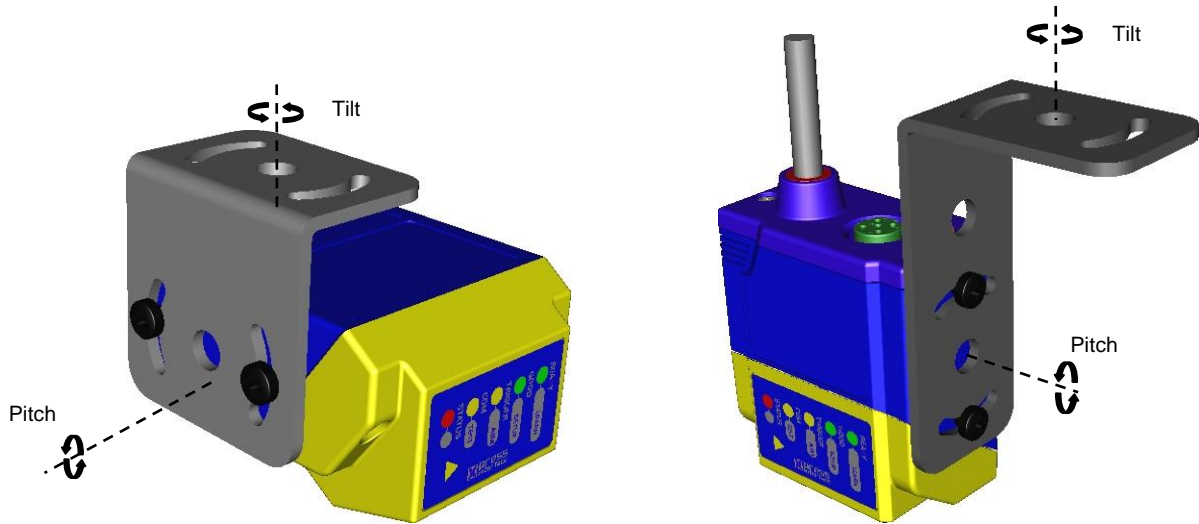

Figure 3 –Positioning 90° and Straight Model with Mounting Bracket



NOTE: For applications where strong vibration or continuous bumps are present, it is recommended to use a double mounting bracket solution.

2. When mounting the Matrix 210™ take into consideration these three ideal label position angles: **Pitch or Skew 10° to 20° and Tilt 0°**, although the reader can read a code at any tilt angle.

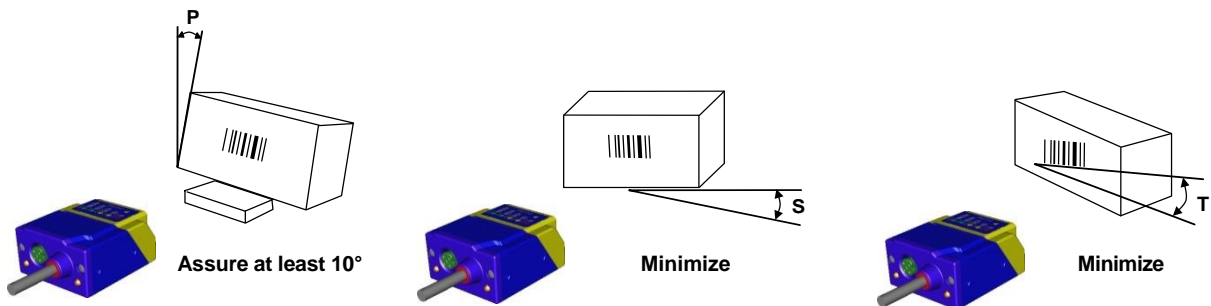

Figure 4 – Pitch, Skew and Tilt Angles

3. Refer to the Reading Features table in chp. 6 to determine the distance your reader should be positioned at.



NOTE: Rapid Configuration of the Matrix 210™ reader can be made **either** through the X-PRESS™ interface (steps 3-4) which requires no PC connection, **or** by using the VisiSet™ Setup Wizard (steps 5-6). Select the procedure according to your needs.

STEP 3 – AIM THE READER

Matrix 210™ provides a built-in aiming system to aid reader positioning. The aiming system is accessed through the X-PRESS™ Interface.

1. Power the reader on. During the reader startup (reset or restart phase), all the LEDs blink for one second. On the connector side of the reader near the cable, the “POWER ON” LED (blue) indicates the reader is correctly powered.
2. Enter the Aim/Locate function by pressing and holding the X-PRESS™ push button until the Aim LED is on.
3. Release the button to enter the Aim function. The aiming system turns on see Figure 5.
4. Place the **application specific code** in front of the reader at the reading distance indicated for your model in the Reading Features Fixed Focus table in par.**Error! Reference source not found.**, centering it in the aiming system indicator.

default value for:
NEAR, MEDIUM,
FAR models



default value for:
UHD models

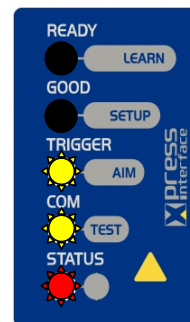
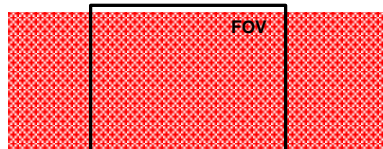

Figure 5 – Aiming Function Using The Blue Ring or Internal Lighting System *

Figure 6 – X-PRESS™ Interface: Aim Function

* the default value of the Aiming System Status parameter can be changed in VisiSet™.

5. Exit the Aim function by pressing the X-PRESS™ push button once. The aiming system turns off.

STEP 4 – X-PRESS™ CONFIGURATION

Once Matrix 210™ is positioned with respect to the code (step 3), you must configure it for optimal code reading relative to your application. This configuration can be performed either through the X-PRESS™ Interface or the VisiSet™ configuration program.

Setup

1. Enter the Setup function by pressing and holding the X-PRESS™ push button until the Setup LED is on.
2. Release the button to enter the Setup function. The Setup LED will blink until the procedure is completed.

The Setup procedure ends when the Image Acquisition parameters are successfully saved in the reader memory, the Setup LED will stop blinking and Matrix 210™ emits 3 high pitched beeps.

If the calibration cannot be reached after a timeout of about 5 (five) seconds Matrix 210™ will exit without saving the parameters to memory, the Setup LED will stop blinking and in this case Matrix 210™ emits a long low pitched beep.

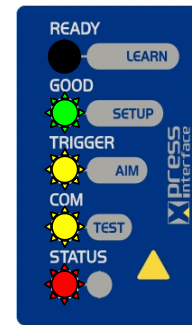

Figure 7 – X-PRESS™ Interface: Setup Function

Learn

3. Enter the Learn function by pressing and holding the X-PRESS™ push button until the Learn LED is on.
4. Release the button to enter the Learn function. The Learn LED will blink until the procedure is completed.

The Learn procedure ends when the Image Processing and Decoding parameters are successfully saved in the reader memory, the Green Spot is activated, the Learn LED will stop blinking and Matrix 210™ emits 3 high pitched beeps¹.

If the autolearning cannot be reached after a timeout of about 3 (three) minutes Matrix 210™ will exit without saving the parameters to memory, the Learn LED will stop blinking and in this case Matrix 210™ emits a long low pitched beep.

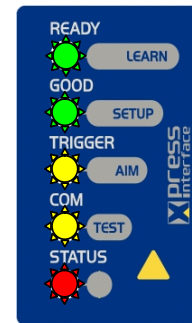

Figure 8 – X-PRESS™ Interface: Learn Function



NOTE: You can exit the Learn function at any time by pressing the X-PRESS™ push button once. After a short delay the Learn procedure is cancelled.

¹ The Learn procedure will not recognize Pharmacode symbolologies.



NOTE: If you have used this procedure to configure Matrix 210™ go to step 7.

RESET READER TO FACTORY DEFAULT (OPTIONAL)

If it ever becomes necessary to reset the reader to the factory default values, you can perform this procedure by holding the X-PRESS™ push button pressed while powering up the reader. **You must keep the X-PRESS™ push button pressed until the power up sequence is completed** (several seconds) and all LEDs blink simultaneously 3 times.

All LEDs remain on for about 1 second, then off for one second, the Configuration and Environmental parameters are reset, and the status LED remains on. If connected through a CBX500 with display module, the message "Default Set" is shown on the display.

STEP 5 – INSTALLING VISISET™ CONFIGURATION PROGRAM

VisiSet™ is a Datalogic reader configuration tool providing several important advantages:

- Setup Wizard for rapid configuration and new users;
- Defined configuration directly stored in the reader;
- Communication protocol independent from the physical interface allowing to consider the reader as a remote object to be configured and monitored.

To install VisiSet™, turn on the PC that will be used for the configuration, running Windows 98, 2000/NT, XP, Vista, 7 or 8. Then run the VisiSet™ installation program (Setup.exe) from the VisiSet™ Mini-DVD (downloaded ISO file or mini-DVD accessory), and follow the installation procedure.

This configuration procedure assumes a laptop computer, running VisiSet™, is connected to the reader's auxiliary port.

After installing and running the VisiSet™ software program the following window:

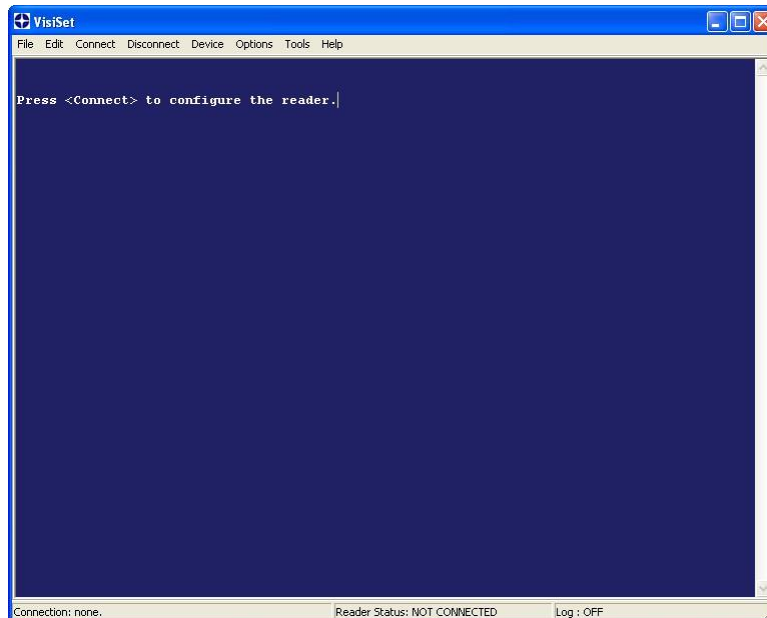

Figure 9 - VisiSet™ Opening Window

Set the communication parameters from the "Options" menu. Then select "Connect", the following window appears:

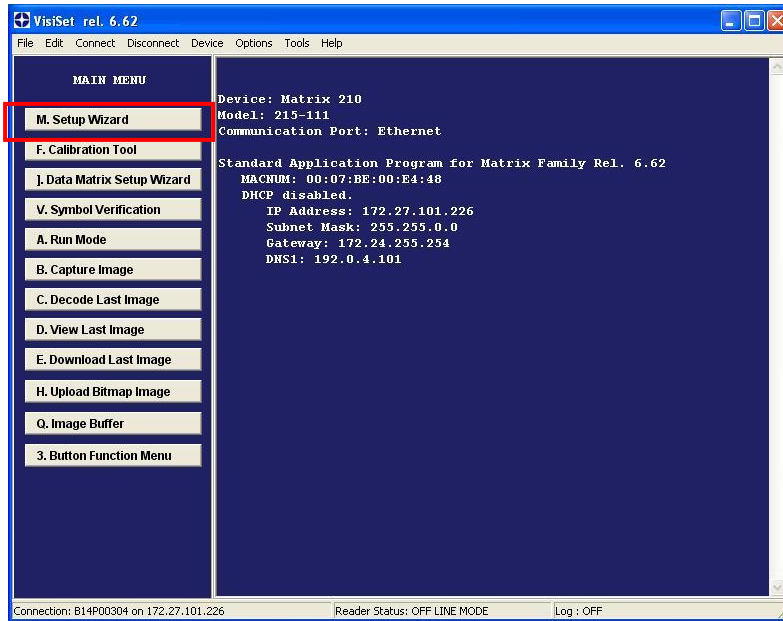
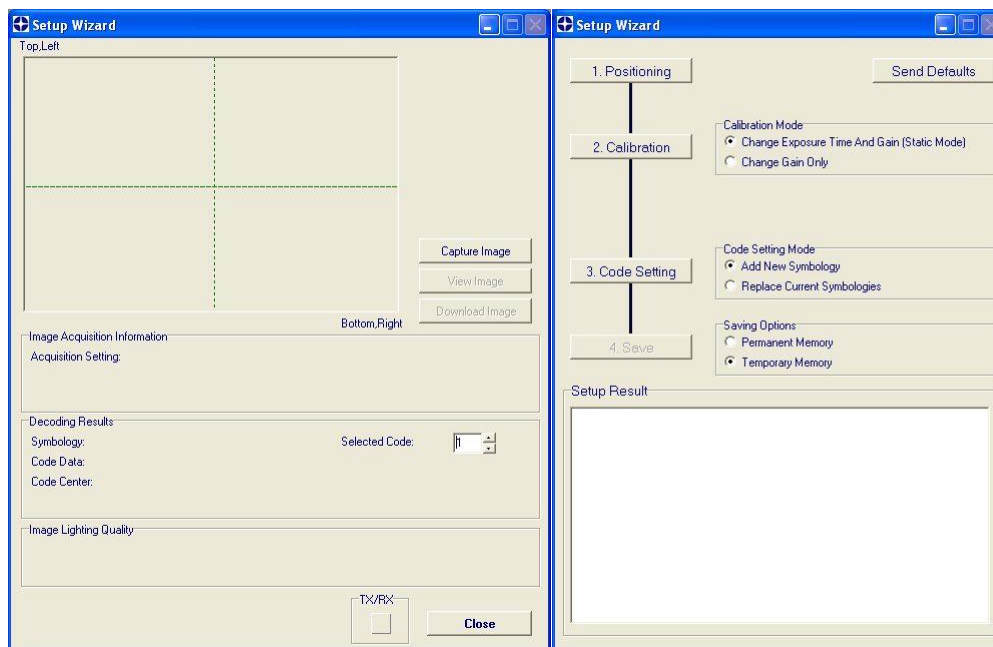

Figure 10 - VisiSet™ Main Window After Connection

STEP 6 – CONFIGURATION USING SETUP WIZARD

The Setup Wizard option is advised for rapid configuration or for new users. It allows reader configuration in a few easy steps.

1. Select the Setup Wizard button from the Main menu.



Place the application specific code in front of the reader at the correct reading distance (see step 2 and the Reading Features table in the chp. 6).

2. Press the "Positioning" button. The reader continuously acquires images and gives visual feedback in the view image window. The Setup Wizard now shows four delimiters (red points) in the acquired images which indicate the region in which the calibration algorithm is active. Move the reader (or code) to center it. Press the Positioning button again to stop positioning.

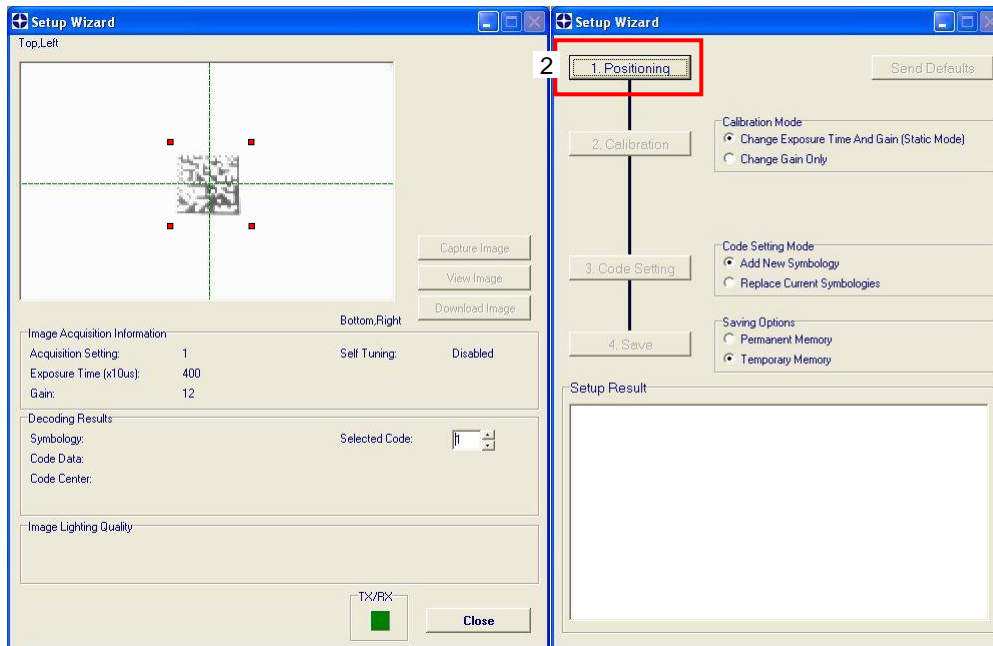

3. Select a Calibration Mode choice and press the "Calibrate" button. The reader flashes once acquiring the image and auto determines the best exposure and gain settings. If the code symbology is enabled by default, the code will also be decoded.

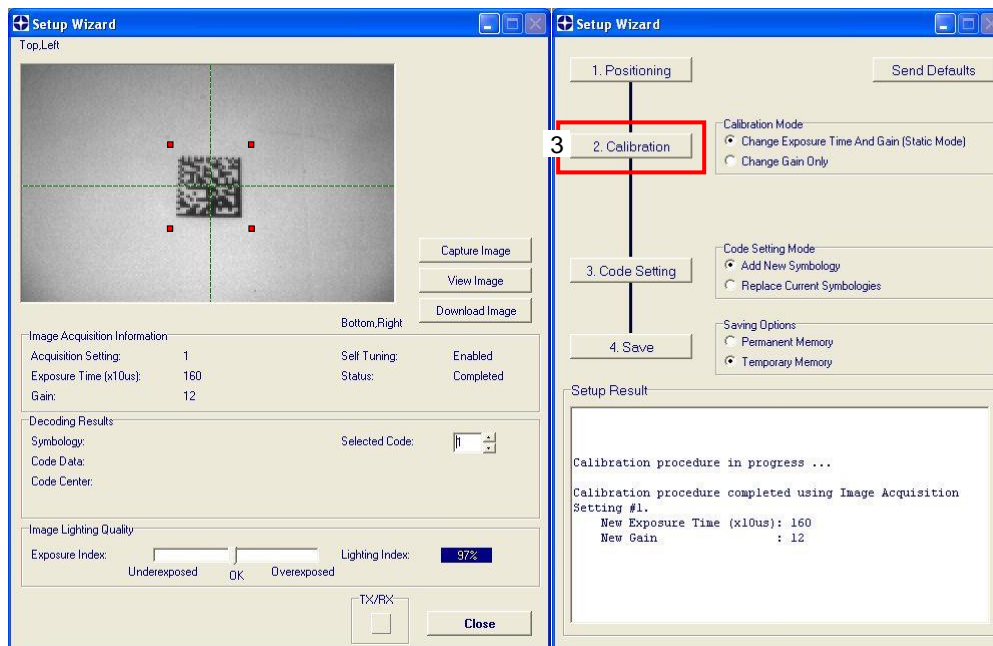

4. Select a Code Setting Mode choice and press the "Code Setting" button.

The Setup Result section of the Setup Wizard window shows the code type results and the parameter settings.

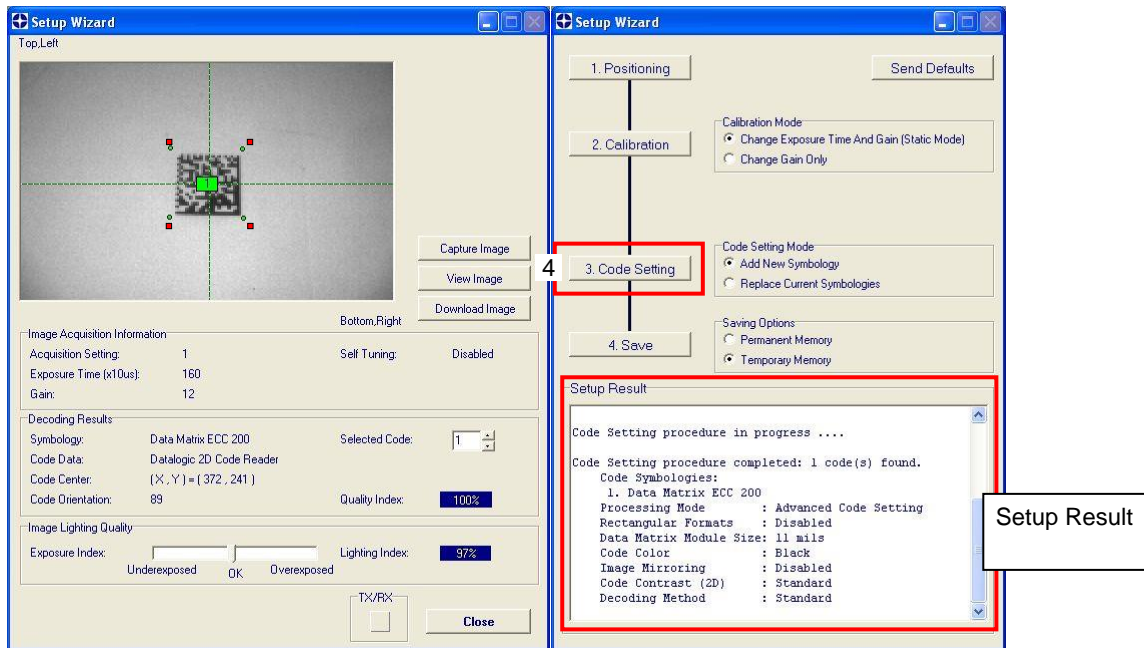

5. Select a Saving Options choice and press the "Save" button.

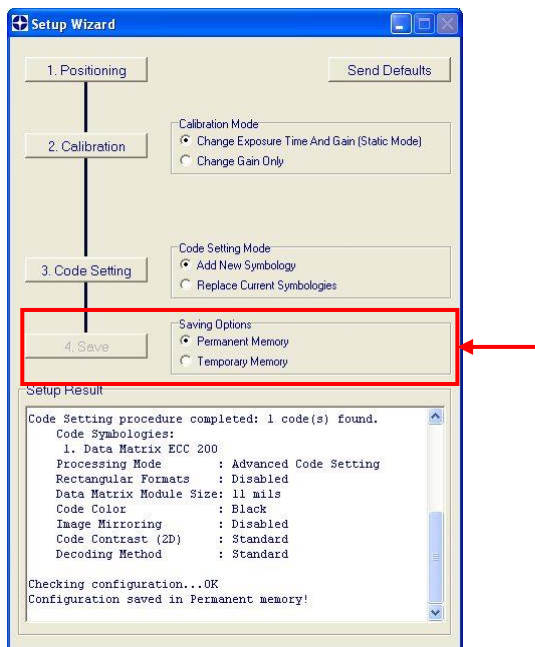

6. Close the Setup Wizard.



NOTE: If your application has been configured using the VisiSet™ Setup Wizard, your reader is ready. If necessary you can use VisiSet™ for advanced reader configuration.

STEP 7 – TEST MODE

Use a code suitable to your application to test the reading performance of the system. Alternatively, you can use the Datalogic 1D/2D Test Chart (Code 39, Data Matrix ECC 200).

1. Enter the *Test* function by pressing and holding the X-PRESS™ push button until the Test LED is on.
2. Release the button to enter the *Test* function.

Once entered, the Bar Graph on the five LEDs is activated and if the reader starts reading codes the Bar-Graph shows the Good Read Rate. In case of no read condition, only the STATUS LED is on and blinks.

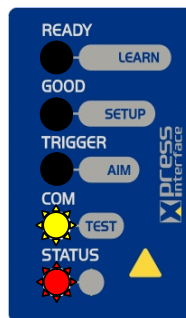

Figure 11 – X-PRESS™ Interface: Test Function

3. To exit the Test, press the X-PRESS™ push button once.



NOTE: By default, the Test exits automatically after three minutes.

The Bar Graph has the following meaning:

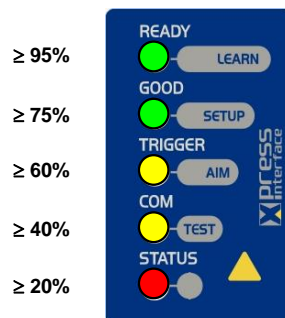

Figure 12 – Test Bar Graph

ADVANCED READER CONFIGURATION

For further details on advanced product configuration, refer to the VisiSet™ Help On-Line. The following are alternative or advanced reader configuration methods:

Advanced Configuration Using VisiSet™

Advanced configuration can be performed through the VisiSet™ program by selecting *Device> Get Configuration From Temporary Memory* to open the Parameter Setup window in off-line mode. Advanced configuration is addressed to expert users being able to complete a detailed reader configuration. The desired parameters can be defined in the various folders of the Parameter Setup window and then sent to the reader memory (either Temporary or Permanent):

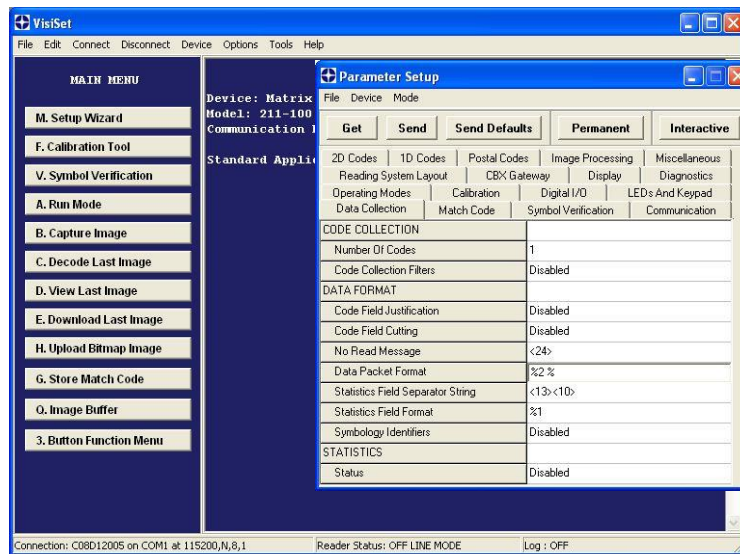

Figure 13 - VisiSet™ Parameter Setup Window

Host Mode Programming

The reader can also be configured from a host computer using the Host Mode programming procedure, by commands via the serial interface. See the Host Mode Programming file from the Start menu (Start>All Programs>Datalogic>VisiSet>Support Files>Host Mode Programming).

Alternative Layouts

If you need to install an Ethernet network, ID-NET™ network, Fieldbus network, Pass-Through network, refer to chapter 5.

The reader can also be setup for alternative layouts by reading programming barcodes. See the "Setup Procedure Using Programming Barcodes" printable from the VisiSet™ Mini-DVD (downloaded ISO file or mini-DVD accessory).

Code Quality Verification

Matrix 210™ can be used as a Code Quality Verifier according to the ISO/IEC 15415, ISO/IEC 15416, AS9132, and AIM DPM Standards.

2 INTRODUCTION

2.1 PRODUCT DESCRIPTION

Matrix 210™ is the new Datalogic 2D reader offering excellent reading performance, ultra compact size and extreme ease of use. Thanks to innovative optical features, advanced software functions and complete connectivity options, Matrix 210™ is the cost effective solution for applications where the space is very limited.

Ultra Compact Size

Compact dimensions, straight and 90° reading window models availability allow flexible mounting and positioning in narrow spaces.

Excellent Reading Performance

WVGA image sensor, up to 60 frames/s acquisition rate and dynamic reading capability, together with powerful decoding libraries provide excellent performance on a wide range of code symbologies as well as damaged and low quality codes. Matrix 210™ allows reading 10 mils codes in moving applications at speeds up to 2 m/sec.

Innovative Optical Features

The innovative optical and lighting systems ensure wide field of view at short reading distances, combined with excellent illumination pattern. Matrix 210™ has a maximum reading distance of 200 mm, and it can read at near distance ultra high density 2D codes up to 0.076 mm (3 mils).

Ease Of Use

The intuitive X-PRESS™ Human Machine Interface makes installation and maintenance easier than ever thanks to a five LED bar graph and the multi-function key providing immediate access to relevant functions such as Aiming, Setup (for automatic imager calibration), Learn (for automatic code setting), Test Mode (for bar graph activation). A Green Spot provides immediate Good Read feedback.

Enhanced Connectivity

An embedded high speed ID-NET™ communication interface allows efficient data collection and simplifies network wiring. USB interface models allow direct connection to a PC.

Industrial Features

Matrix 210™, with its rugged construction, IP65 protection class, 50°C max operating temperature and 10 to 30 VDC power supply is the ideal product for industrial applications.

Matrix 210™ has been developed for use in numerous industries like:

Electronics:

- PCB Board Tracking
- Electronics Product Tracking

Pharmaceutical & Chemical:

- Medical Devices Traceability
- Pharmaceutical and Medicine Manufacturing

OEM:

- Chemical & Biomedical Analysis Machines
- Access Control Systems
- Self Service Systems (ATM, Kiosks)
- Print & Apply systems
- Document Handling

This technology intrinsically provides omni-directional reading.

Standard Application Program

A Standard Application Program is factory-loaded onto Matrix 210™. This program controls code reading, data formatting, Ethernet interfacing, serial port and USB interfacing, and many other operating and control parameters. It is completely user configurable from a Laptop or PC using the dedicated configuration software program VisiSet™, provided on the VisiSet™ Mini-DVD (downloaded ISO file or mini-DVD accessory).

There are different programmable operating modes to suit various code reading system requirements.

Quick, automatic positioning, calibration and code setting of the imager can be accomplished using the X-PRESS™ button and LEDs on top of the reader without the necessity of a PC.

The previous functions can also be performed through VisiSet™ through the Setup Wizard. This tool includes visual feedback from the reader.

VisiSet™ provides a Calibration Tool to verify the exact positioning of the reader and to maximize its reading performance.

Statistics on the reading performance can also be visualized through a dedicated window in VisiSet™.

Symbol Verification can be performed through VisiSet™ when the reader has been installed and setup as a Verifier station.

Programmability

If your requirements are not met by the Standard Application Program, Custom Application Programs can be requested at your local Datalogic distributor.

Some of the main features of this reader are given below:

- Ultra Compact Dimensions
- Direct and 90° window models for smart mounting
- Outstanding decoding capability on 1D, 2D, Stacked and Postal symbologies
- High performance on dynamic reading applications
- X-PRESS™ for easy and intuitive setup
- Optical Aiming System
- 10 to 30 VDC Power Supply
- High Speed Ethernet Connectivity
- USB Connectivity
- ID-NET™ embedded high speed connectivity
- Region Of Interest Windowing for higher frame rate
- Run Time Self Tuning for higher flexibility

2.2 INDICATORS AND KEYPAD BUTTON

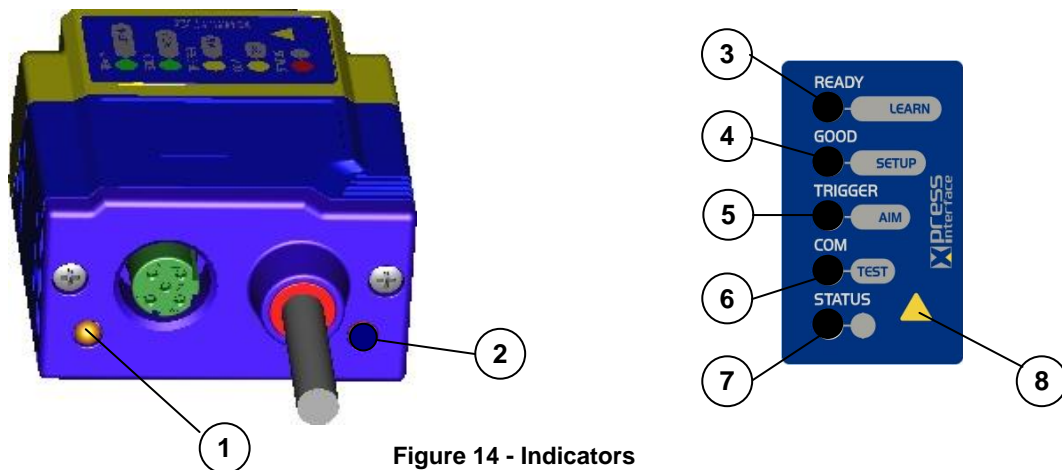

Figure 14 - Indicators

The following LED indicators are located on the reader:

NET	For Ethernet models, on the connector side of the reader near the Ethernet connector, the orange ETHERNET NETWORK PRESENCE LED indicates the on-board Ethernet network connection. (Figure 14, 1)
PWR	On the connector side of the reader near the cable, the blue POWER ON LED indicates the reader is correctly powered. (Figure 14, 2)

In normal operating mode the colors and meaning of the five LEDs are illustrated in the following table:

READY	green LED indicates that the reader is ready to operate (Figure 14, 3)
GOOD	green LED confirms successful reading (Figure 14, 4)
TRIGGER	yellow LED indicates the status of the reading phase (Figure 14, 5)
COM	yellow LED indicates active communication on the main serial port * (Figure 14, 6)
STATUS	red LED indicates a NO READ result (Figure 14, 7)

* When connected to a Fieldbus network through the CBX500, the COM LED is always active, even in the absence of data transmission, because of polling activity on the Fieldbus network.

During the reader startup (reset or restart phase), these five LEDs blink for one second.

In X-PRESS™ Configuration mode the colors and meaning of these five LEDs are described in par. 2.4.

The keypad button (Figure 14, 8, is software programmable. By default it starts the X-PRESS™ interface for quick installation without using a PC (see chp. 1).

2.3 ID-NET™

The ID-NET™ network is a built-in high-speed interface dedicated for high-speed reader interconnection. ID-NET™ is in addition to the Main and Auxiliary serial interfaces.



The following network configurations are available:

- **ID-NET™ M/S Synchronized:** Single station – multiple readers

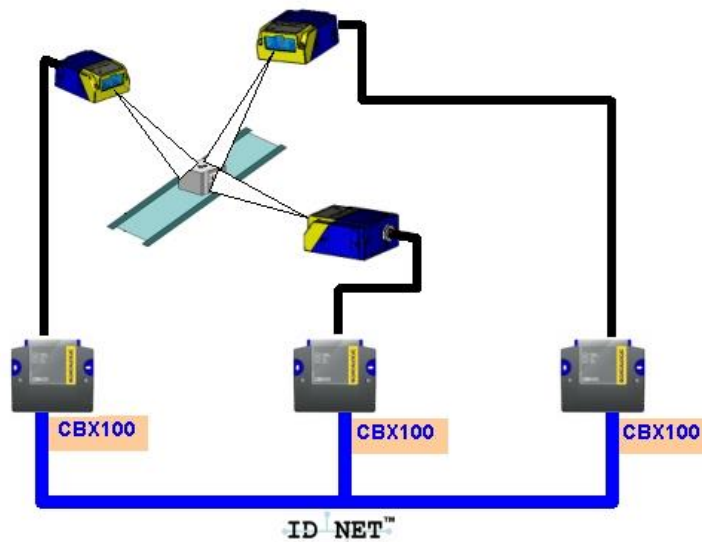

ID-NET™ interface allows local connection of multiple readers reading different sides of the same target. All readers share a single presence sensor and activate/deactivate simultaneously.

At the end of each reading phase a single data message is transmitted to the host.

Thanks to ID-NET™, data communication among readers is highly efficient so that an immediate result will be available.

- **ID-NET™ M/S Multidata:** Multiple stations – single reader

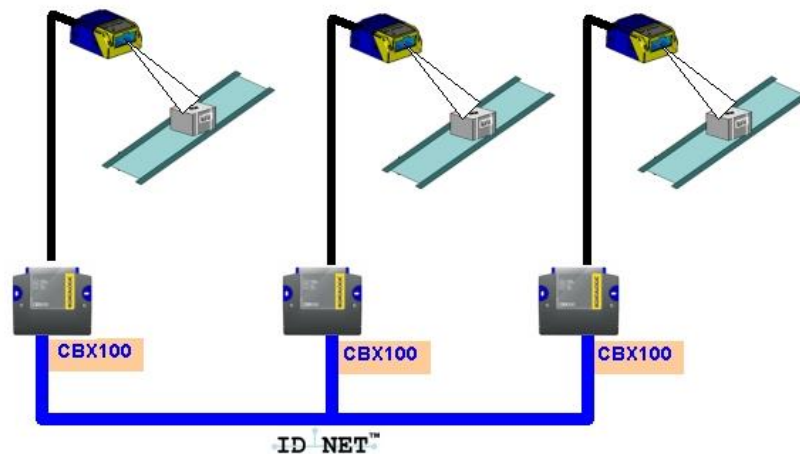

ID-NET™ interface allows connection of readers reading objects placed on independent conveyors. All readers are typically located far away from each other and they use a dedicated presence sensor.

At the end of each reading phase, each reader transmits its own data message to the host. Thanks to ID-NET™, data collection among readers is accomplished at a high speed without the need of an external multiplexing device. This leads to an overall cost reduction and to a simple system wiring.

2.3.1 How To Setup/Configure the Reader Network

A complete ID-NET™ reader network can be easily setup through VisiSet™ as follows:

Mounting & Connection

1. Mechanically mount/install all the readers (refer to par. 3.2 and 3.3).
2. Wire ID-NET™ (refer to par. 4.3 or **Error! Reference source not found.**).
3. Power up the entire system.

Configuration of Slaves

1. Connect a PC equipped with VisiSet™ to the Main, Auxiliary or Ethernet interface of the planned Slave reader.
2. Launch VisiSet™ and connect to the Slave reader.
3. From the VisiSet™ Device Menu select "Parameter Setup".
4. Set the Role of the Slave reader (Synchronized or Multidata) from the Reading System Layout > Device Network Setting > Topology Role parameter.
5. Set the Slave Address according to the desired value **1-31** from the Reading System Layout > Device Network Setting > Slave Address parameter. Each reader must have a different Address on the ID-NET™ Network.
6. If necessary, set the ID-NET™ baudrate from the Reading System Layout > Device Network Setting > Network Baud Rate parameter, (500 kbs default).

7. Configure the other device parameters via VisiSet™ [Operating Mode, Calibration, Data Collection parameters, etc.].
8. The Slave device is now Configured. Physically connect it to the Master/Slave network. If using the CBX connection box equipped with a BM100 Backup module, you can perform Device Backup at the Slave (see par. 2.4 for details).

Repeat these steps for each Slave reader in the ID-NET™ network.

Configuration of Master

1. Connect a PC equipped with VisiSet™ to the Main, Auxiliary or Ethernet interface of the planned Master reader.
2. Launch VisiSet™ and connect to the Master reader.
3. From the VisiSet™ Device Menu select "Parameter Setup".
4. Set the Role of the Master reader (Synchronized or Multidata) from the Reading System Layout > Device Network Setting > Topology Role parameter.
5. Enable the planned Slave device N from the Reading System Layout > Expected Slave Device #N > Status parameter and, if desired, set the related identification string from the Expected Slave Device #N > Device Description parameter. Repeat this step for all planned Slave devices.
6. If necessary, set the ID-NET™ baudrate from the Reading System Layout > Device Network Setting > Network Baud Rate parameter, (500 kbs default).
7. Configure the other device parameters via VisiSet™ [Operating Mode, Calibration, Data Collection parameters, etc.].
8. The Master device is now Configured. Physically connect it to the Master/Slave network. If using the CBX connection box equipped with a BM100 Backup module, perform a Network Backup at the Master (see par. 2.4 for details).
9. From the VisiSet™ Device Menu select "ID-NET™ Status Window" and click on the "Look For Devices On Network" button to check the status of the expected Slave devices within the ID-NET™ network.

Slave Address	Requested Status	Current Status	Device Description	Serial Number	Parameter
1	Enabled	Present	Matrix 210	C10P01554	Get
2	Enabled	Present	Matrix 210	C10P01548	Get
3	Enabled	Present	Matrix 210	C10P01552	Get
4	Enabled	Present	Matrix 210	C10P01550	Get
5	Enabled	Present	Matrix 210	C10P01551	Get
6	Enabled	Present	Matrix 210	C10P01553	Get
7	Enabled	Present	Matrix 210	C10P01549	Get

The reader network is ready.

2.3.2 ID-NET™ Slave Management Through Master

When an ID-NET™ layout has already been configured, it is possible to modify the configuration of any Slave from VisiSet through the Master.

1. Connect a PC equipped with VisiSet™ to the Main, or Auxiliary interface of the Master reader.
2. Launch VisiSet™ and connect to the Master reader.
3. From the VisiSet™ Device Menu select "ID-NET™ Status Window" and click on the "Look For Devices On Network" button to check the status of the expected Slave devices within the ID-NET™ network.
4. Click anywhere in the row of the specific slave in the ID-NET Status Window when its Current Status is "Present". The Parameter Setup window will be displayed after a time based on the network speed, with the configuration of the selected slave.
5. From the specific Slave Parameter Setup Window, change any parameter (not in interactive mode), save the configuration to a file, or load a configuration from a file.
6. Send the modified configuration to the slave.

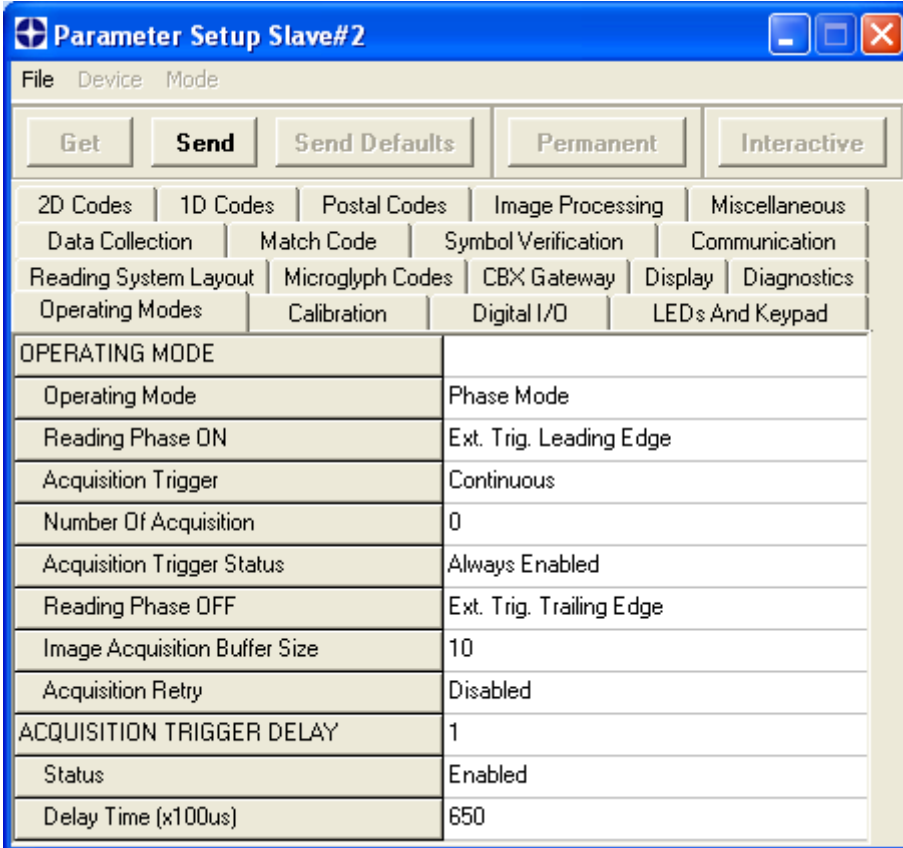

The screenshot shows a software window titled "Parameter Setup Slave#2" with a menu bar (File, Device, Mode) and several buttons: Get, Send, Send Defaults, Permanent, and Interactive. Below the buttons is a grid of tabs for different configuration categories: 2D Codes, 1D Codes, Postal Codes, Image Processing, Miscellaneous, Data Collection, Match Code, Symbol Verification, Communication, Reading System Layout, Microglyph Codes, CBX Gateway, Display, Diagnostics, Operating Modes, Calibration, Digital I/O, and LEDs And Keypad. The "OPERATING MODE" section is expanded, showing a list of parameters and their current values:

OPERATING MODE	
Operating Mode	Phase Mode
Reading Phase ON	Ext. Trig. Leading Edge
Acquisition Trigger	Continuous
Number Of Acquisition	0
Acquisition Trigger Status	Always Enabled
Reading Phase OFF	Ext. Trig. Trailing Edge
Image Acquisition Buffer Size	10
Acquisition Retry	Disabled
ACQUISITION TRIGGER DELAY	1
Status	Enabled
Delay Time (x100us)	650



CAUTION: If a wrong configuration is set or if the Slave Reading System Layout parameters are changed, the slave could lose the network connection.

2.4 EXTERNAL MEMORY BACKUP AND RESTORE THROUGH VISISET™

The "External Memory Backup" or "External Memory Restore" functions allow performing Complete Configuration and Environmental parameter storage for network and reading devices. Backup & Restore can be applied to any reader connected through a device having External Backup Memory, regardless of the reader's network configuration. Backup & Restore automatically checks whether a previous backup or configuration is already available for each device, speeding the procedure up and making it more secure.

These functions are supported by VisiSet™ for all reading devices having sw 6.10 and later when connected to:

- CBX + BM100 and/or BM2x0 (sw release 2.02.01 and later)
- QL500 (Ethernet TCP/IP) (sw release 2.02.01 and later)
- QLM-Series Gateways (reading device sw release 6.50 and later)



NOTE:

- Before executing a Backup on a BM100 backup module make sure the Write Protection switch is set to Unlocked.
- If BM100 and BM2x0 are both installed B&R is automatically performed only on the BM100 module.
- BM2x0 can execute B&R only with Network up and running (network cable connected).

QL500 can backup up to 10 nodes (Master + 9 slaves).

Backup

To perform a **Backup**:

1. Select "External Memory Backup" from the VisiSet™ Device menu
2. You will be warned that the previous backup will be overwritten. Confirm by clicking Yes.

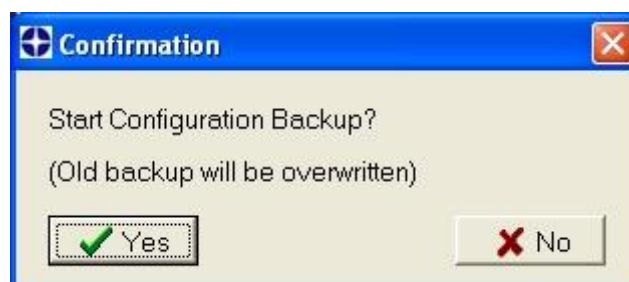

The VisiSet™ Main window shows information as the backup procedure is performed and a message indicating successful completion.

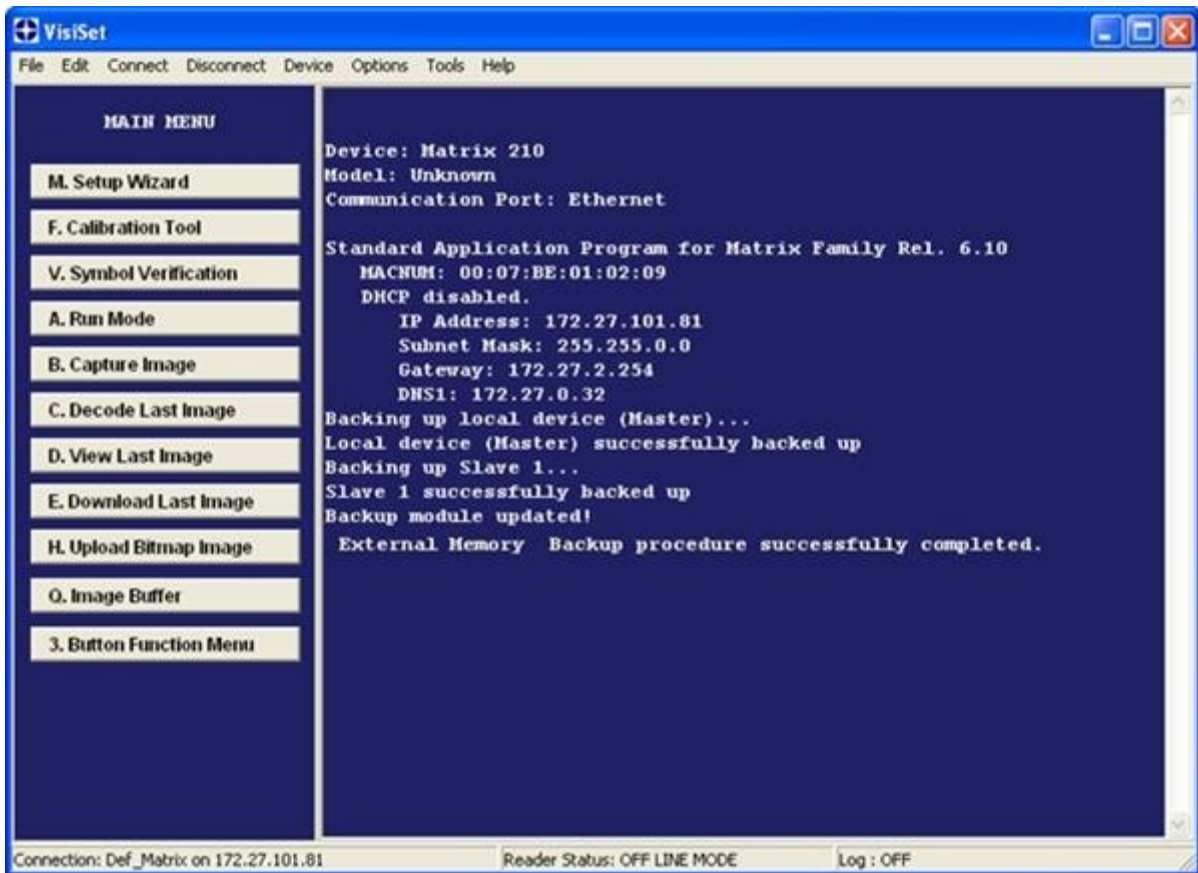

Restore

To perform a **Restore**:

1. Select "External Memory Restore" from the VisiSet™ Device menu
2. You will be warned that the current device configuration(s) will be overwritten. Confirm by clicking Yes.

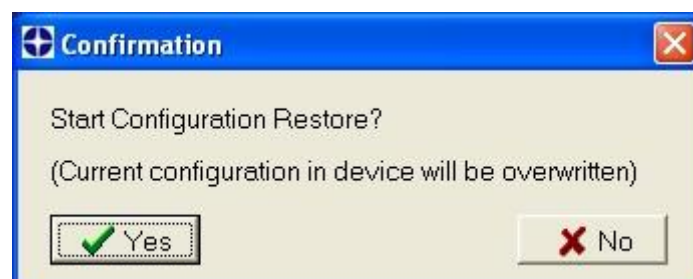

The VisiSet™ Main window shows information as the restore procedure is performed and a message indicating successful completion.

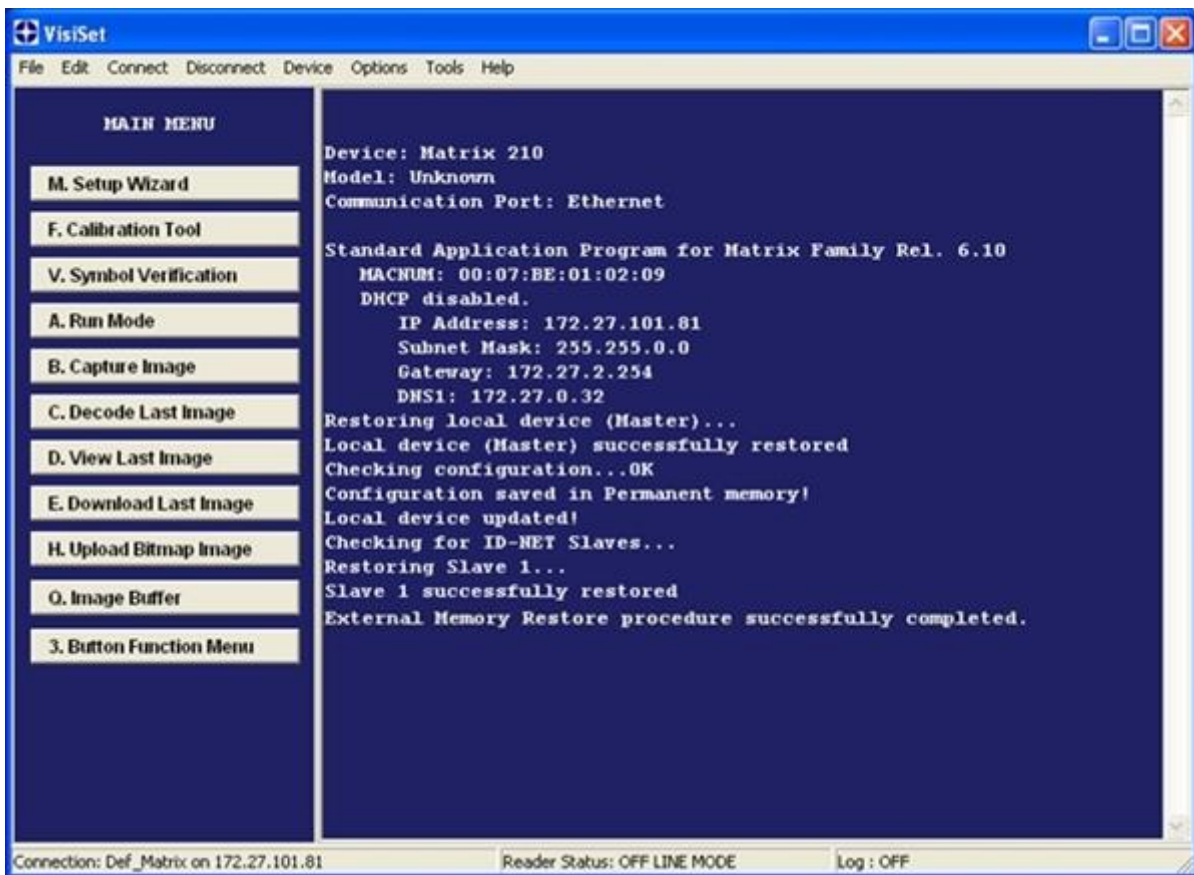

Replacement

The **External Memory Restore** function also provides easy and secure Single Device Replacement:

1. Remove the device to be replaced
2. Connect the new device (make sure the new device has been previously set to default)
3. Run the Restore procedure by selecting the "External Memory Restore" item (see: Restore procedure)

Erase

To **Erase** any previous Backup:

1. Select "External Memory Erase" from the VisiSet™ Device menu
2. You will be warned that all device configurations in the current backup will be erased. Confirm by clicking Yes.

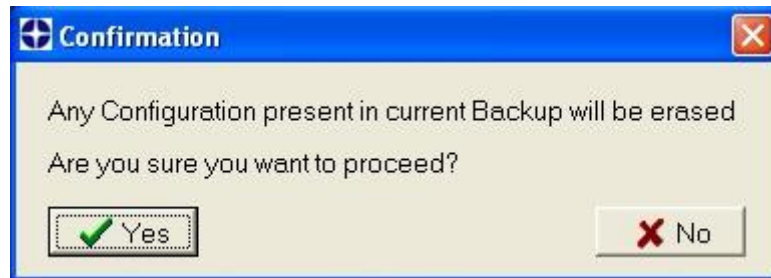

The VisiSet™ Main window shows a message indicating successful completion.

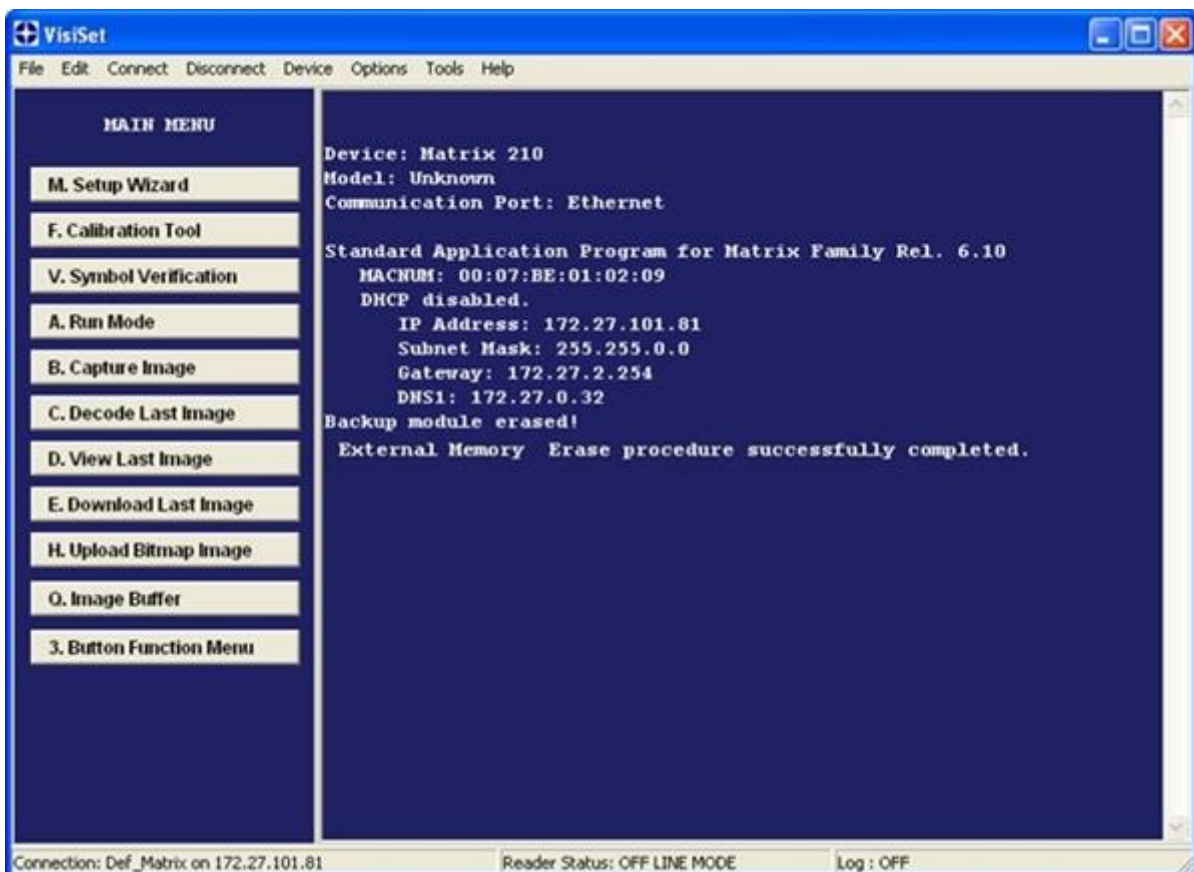

List

To see a **List** of the current Backup:

1. Select "External Memory Read Backup" from the VisiSet™ Device menu.

The VisiSet™ Main window shows a list of devices in the current Backup.



The following is a list of possible error messages displayed on the VisiSet™ main window in case of an External Memory function failure:

- **Module not present:** backup module not mounted (BM100) or not ready (QL500, BM2x0)
- **Unable to Read Backup State:** VisiSet™ is unable to connect to the backup memory
- **Backup function not allowed:** when device is in X-PRESS™ Menu mode (BM100, QLM) or is out of memory (QL500)
- **Failed! (Device not found):** Master is unable to reach the addressed device
- **Failed! (Module is write protected):** BM100 Write Protection switch is set to Locked

2.5 X-PRESS™ HUMAN MACHINE INTERFACE

X-PRESS™ is the intuitive Human Machine Interface designed to improve ease of installation and maintenance.

Status information is clearly presented by means of the five colored LEDs, whereas the single push button gives immediate access to the following relevant functions:

- Learn to self-detect and auto-configure for reading unknown codes.
- Setup to perform Exposure Time and Gain calibration.
- Aim/Locate to turn on the blue ring to aid positioning.
- Test with bar graph visualization to check static reading performance.

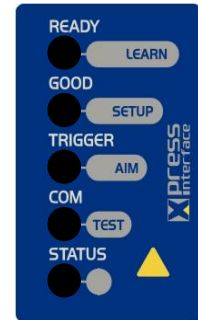

2.5.1 X-PRESS™ Functions

Quick access to the following functions is provided by an easy procedure using the push button:

- 1 – **Press** the button (the Status LED will give a visual feedback).
- 2 – **Hold** the button until the specific function LED is on (Test, Focus, Setup or Learn).
- 3 – **Release** the button to enter the specific function.



Once button is pressed, the cycle of LEDs activation is as follows:

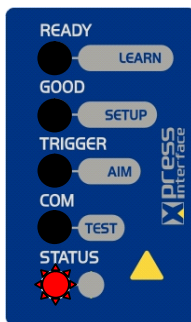

Release button
to Exit

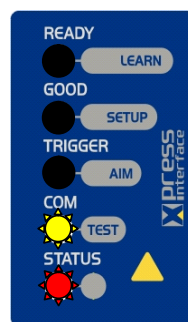

Release button
to enter Test Mode

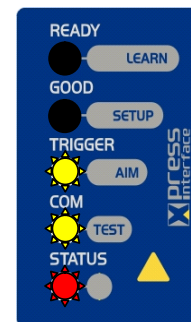

Release button
to enter Aim/Locate Mode



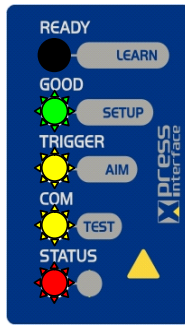

Release button
to enter Setup Mode

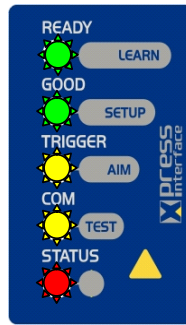

Release button
to enter Learn Mode

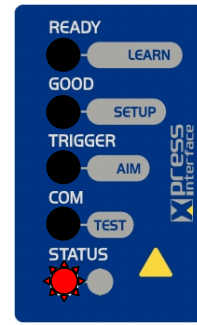

Release button
to Exit

→ (cycle)

Test Mode (Function 1)

Once entered, the Bar Graph on the five LEDs is activated and if the imager starts reading codes the Bar-Graph shows the Good Read Rate. In case of a NO READ condition, only the Status LED is on and blinks.

The Bar Graph has the following meaning:

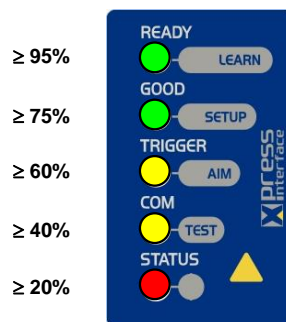

To exit the Test Mode, press the X-PRESS™ push button once.



NOTE: By default, the Test exits automatically after three minutes.

Aim/Locate (Function 2)

This function causes the blue ring to turn on. Since the blue ring is centered on the FOV it can be used to position the imager on the code. The Aim LED blinks to indicate this state.

To exit the Aim/Locate Mode, press the X-PRESS™ push button once. The blue ring turns off.

Setup (Function 3)

Once entered, the imager automatically performs Image Acquisition parameter calibration for the specific code presented to it.

The Setup LED will blink until the procedure is completed.

The Setup procedure ends when the Image Acquisition parameters are successfully saved in the reader memory, the Setup LED will remain on continuously and Matrix 210™ emits 3 high pitched beeps.

If the calibration cannot be reached after a timeout of about 5 (five) seconds Matrix 210™ will exit without saving the parameters to memory, the Setup LED will not remain on continuously but it will just stop blinking. In this case Matrix 210™ emits a long low pitched beep.

Learn (Function 4)

Once entered, the imager starts a procedure to automatically detect and recognize codes which are presented to it.

The Learn LED will blink until the procedure is completed.

The Learn procedure ends when the Image Processing and Decoding parameters are successfully saved in the reader memory, the Learn LED will remain on continuously and Matrix 210™ emits 3 high pitched beeps.

If the calibration cannot be reached after a timeout of about 3 (three) minutes, Matrix 210™ will exit without saving the parameters to memory, the Learn LED will not remain on continuously but it will just stop blinking. In this case Matrix 210™ emits a long low pitched beep.

2.5.2 Diagnostic Indication

The "STATUS" and "READY" LEDs blink simultaneously while the "GOOD" LED is on to signal the presence of an error. Diagnostic message transmission on interfaces can be enabled to provide details about specific error conditions. See the Diagnostic Error Conditions chart in the Help On Line.

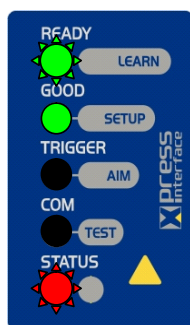

LED	STATUS
READY	BLINK
GOOD	ON to indicate an error
TRIGGER	
COM	
STATUS	BLINK

2.6 MODEL DESCRIPTION

Matrix 210™ readers are described by their model number which indicates the characteristics listed in the diagram below. Not all combinations are available. For a complete list of combinations see the Models tab on the Product page of the website.

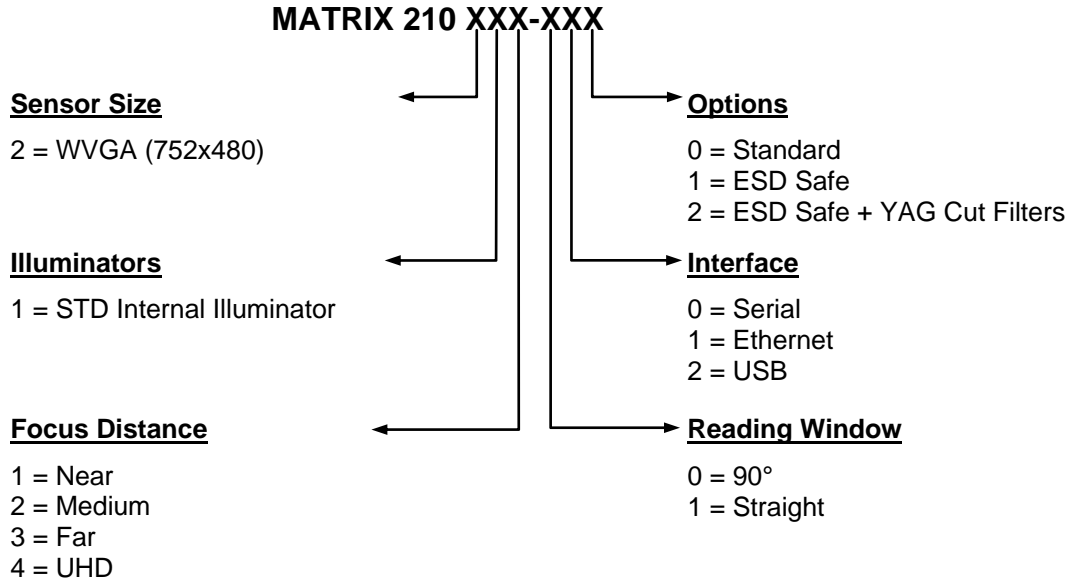

2.7 ACCESSORIES

The following accessories can be used with the Matrix 210 2xx-x0x and Matrix 210 2xx-x1x model readers.

Accessory	Description	Order No.
External Illuminator		
LT-700	Linear Array Lighting System	93A401028
BK-21-000	LT-700 Fixing Bracket	93ACC0052
Cables		
CAB-ETH-M01	M12-IP67 Ethernet Cable (1M)	93A051346
CAB-ETH-M03	M12-IP67 Ethernet Cable (3M)	93A051347
CAB-ETH-M05	M12-IP67 Ethernet Cable (5M)	93A051348
Connectivity		
CBX100	Compact Connection Box	93A301067
CBX500	Modular Connection Box	93A301068
BM100	Backup Module for CBX100/500	93ACC1808
BM150	Display Module for CBX500	93ACC1809
BM200/BM210	Ethernet TCP/IP Module STD/IP65 for CBX500	93ACC1851, 93ACC1852
BM300/BM310	Profibus Module STD/IP65 for CBX500	93ACC1810, 93ACC1811
BM400	DeviceNet Module IP65 for CBX500	93ACC1814
BM500/BM510/BM520	EtherNet/IP Module STD/IP65/IP54 for CBX500	93ACC1812, 93ACC1813, 93ACC1840
BM600	CAN Open Module for CBX500	93ACC1815
BM700	Profinet IO Module for CBX500	93ACC1816
BM1100	CC-Link Module for CBX500	93ACC1845
BM1200/BM1210	Modbus TCP Module STD/IP65 for CBX500	93ACC1848, 93ACC1849
BA100	DIN Rail Adapters	93ACC1821
BA200	Bosch Adapters	93ACC1822
QL150	Quick Link Slave ID-NET + Service T-Connector	93ACC1868
QL300	Quick Link Master ID-NET - Serial Host Connector	93ACC1862
QL500	Quick Link Master ID-NET - Ethernet Host Connector	93ACC1864
QLM500	Quick Link Metal Master ID-NET - EtherNet/IP Gateway	93ACC0037
QLM600	Quick Link Metal Master ID-NET - Profibus Gateway	93ACC0033
QLM700	Quick Link Metal Master ID-NET - Profinet IO Gateway	93ACC0038
Power Supplies		
PG6002	AC/DC Power Supply Unit (US)	93ACC1718
PG6001	AC/DC Power Supply Unit (UK)	93ACC1719
PG6000	AC/DC Power Supply Unit (EU)	93ACC1720
Sensors		
MEP-593	Photocell Kit PNP (PH-1)	93ACC1791
MEP-543	Photocell Kit-NPN	93ACC1728



NOTE: Matrix 210™ 2xx-x2x models, (USB), are used for point-to-point connections to PCs or USB Hubs and have no accessories.

2.8 APPLICATION EXAMPLES

2.8.1 Document Handling

Matrix 210™ is profitably used in the omnidirectional reading of 2D, stacked, linear and postal codes for example in automated document handling and mail processing systems (see Figure 15).



Figure 15 - Address Coded in Data Matrix Symbology for Automated Mail Processing

2.8.2 Deformed or Overprinted Code Reading

Matrix 210™ assures the reading of deformed and / or overprinted codes, even though damaged or printed on high reflective surfaces (see Figures 18, 19, 20).



Figure 16 - Unidose Flow-Pack with PDF417 Code



Figure 17 - Overprinted Barcode Readable by Matrix 210™ also Through the Envelope Window Film



Figure 18 - Barcode Printed on Curved Surface Readable by Matrix 210™ in spite of Image Optical Distortion

2.8.3 Direct Part Marking

Matrix 210™ is also very powerful in reading low-contrast direct part marked codes (see Figures 21, 22, 23, 24 and 25).



Figure 19 - Dot Matrix Code Directly Marked on Metal Surface by Using Dot Peening Technology

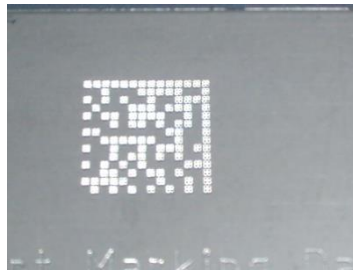

Figure 20 - Dot Peening Marking on Metal Surface with Multi-dot per Code Element

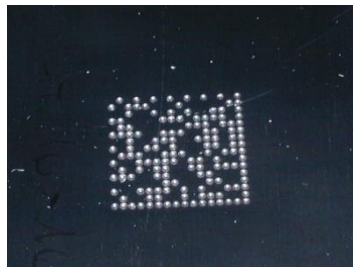

Figure 21 - Directly Marked Dot Matrix Code Characterized by Outstanding Separation Distance between Adjacent Code Elements

2.8.4 Ink-Jet Printing Technology

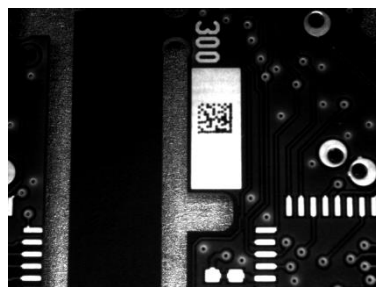

Figure 22 - Dot Matrix Code Directly Marked on PCB Copper Pad by Using Ink-Jet Technology

2.8.5 Laser Marking/Etching Technology

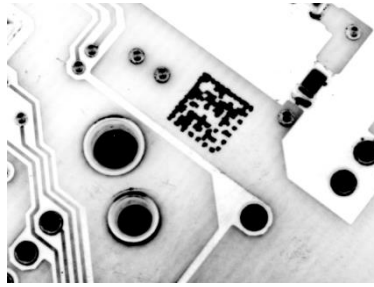

Figure 23 - Data Matrix Code Directly Marked on PCB Surface by Using Laser Etching Technology



CAUTION: If application codes must be read which are produced by Laser Marking in real time, use Matrix 210™ models incorporating YAG Filters in order to avoid burning the CMOS sensor.

2.9 EXTERNAL LIGHTING SYSTEMS

In some direct part marking applications best reading results are obtained by using an external lighting system.

The LT-700 Linear Array Lighting System provides a high intensity light source designed for the following applications:

- with uneven, noisy and scratched surfaces
- where dot peening or laser etching codes are directly marked onto metal surfaces or PCBs and need to be highlighted. Here the use of more than one LT-700 at different positions can remove any shadowing effect.
- in the presence of highly reflective surfaces (metal, glass, etc.) causing direct reflections. Low light path to surface angles strongly reduce direct reflections.



Figure 24 - LT-700 Linear Array Lighting System

3 INSTALLATION

3.1 PACKAGE CONTENTS

Verify that the Matrix 210™ reader and all the parts supplied with the equipment are present and intact when opening the packaging; the list of parts includes:

- ❑ Matrix 210™ reader
- ❑ Quick Reference Guide
- ❑ Test Chart
- ❑ Mounting Kit
 - Mounting Screws (2)
 - Washers (2)
 - Mounting Bracket

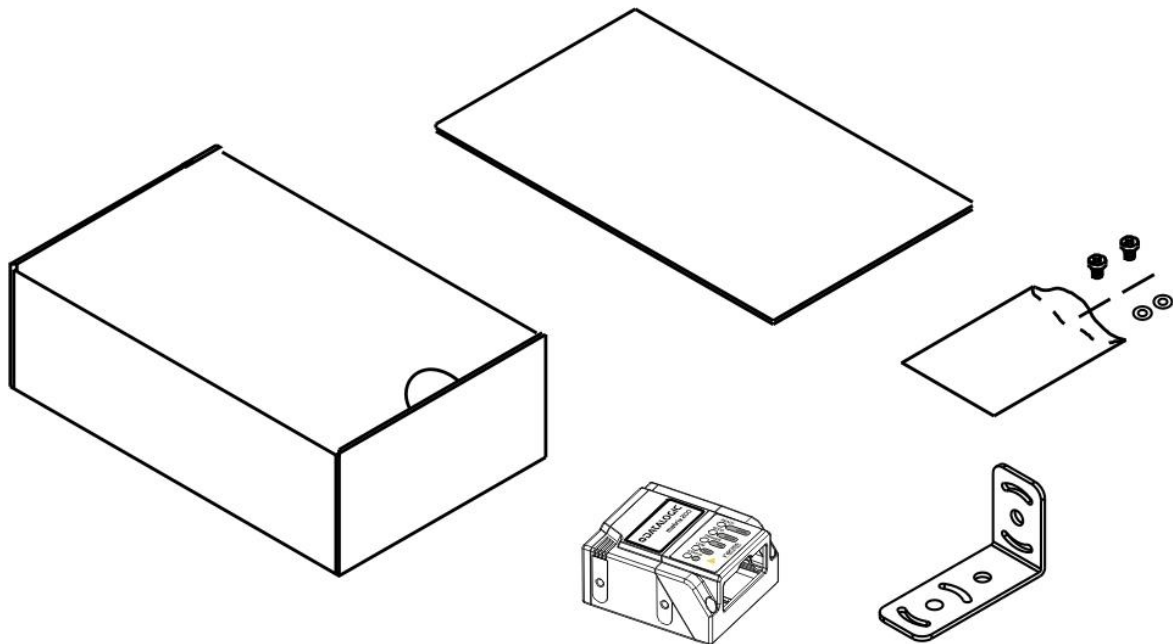

Figure 25 - Package Contents

3.2 MECHANICAL DIMENSIONS

Matrix 210™ can be installed to operate in different positions. The four screw holes (M3 x 4) on the body of the reader are for mechanical fixture (Figure 26).

The diagram below gives the overall dimensions of the reader and may be used for its installation.

Refer to par. 3.3 for various mounting solutions and correct positioning and chp. 6 for Reading Distance considerations.

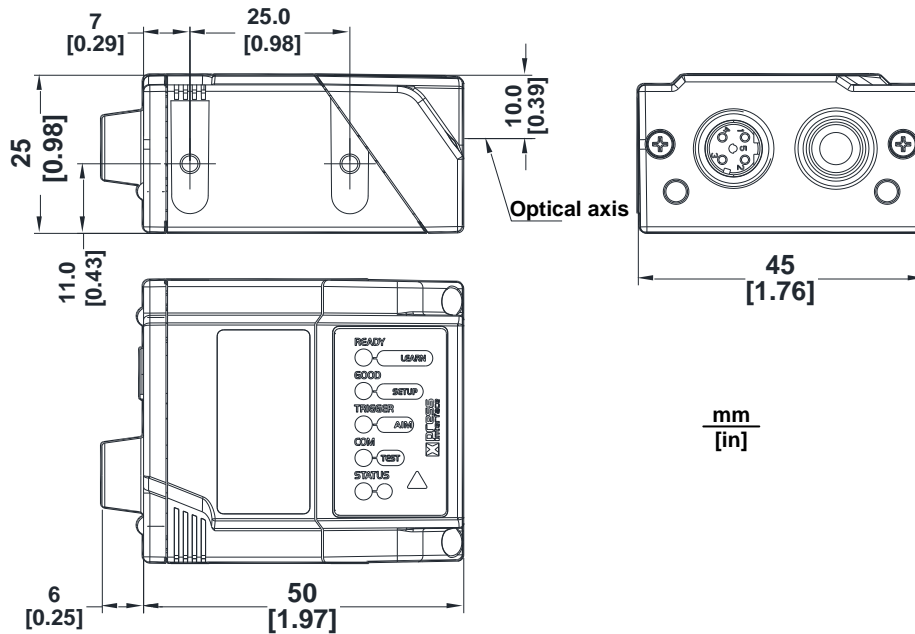

Figure 26 – Straight Model Overall Dimensions

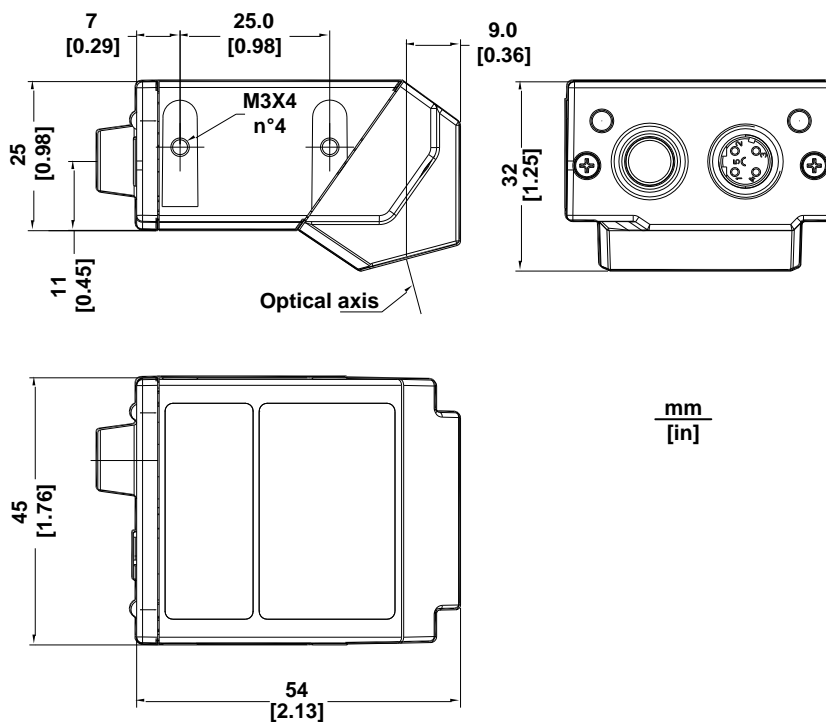

Figure 27 – 90° Model Overall Dimensions

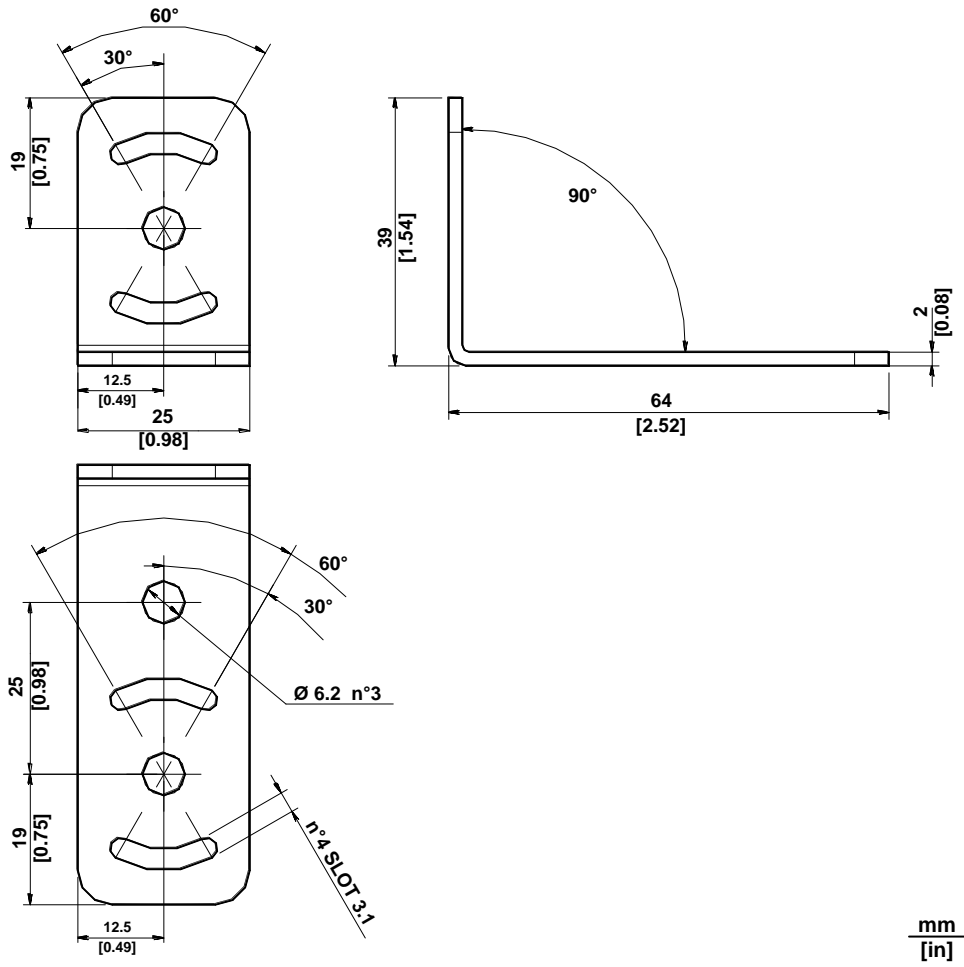

Figure 28 - ST-336 Mounting Bracket Overall Dimensions

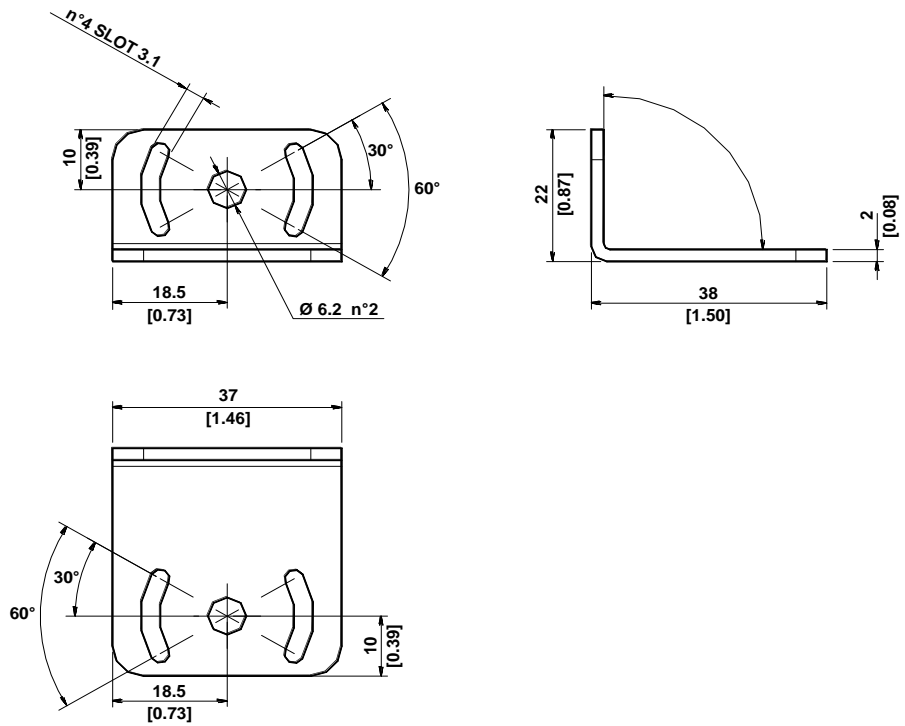

Figure 29 - ST-337 Mounting Bracket Overall Dimensions

3.3 MOUNTING AND POSITIONING MATRIX 210™

Using the Matrix 210™ mounting brackets you can obtain rotation on the various axes of the reader as shown in the diagrams below:

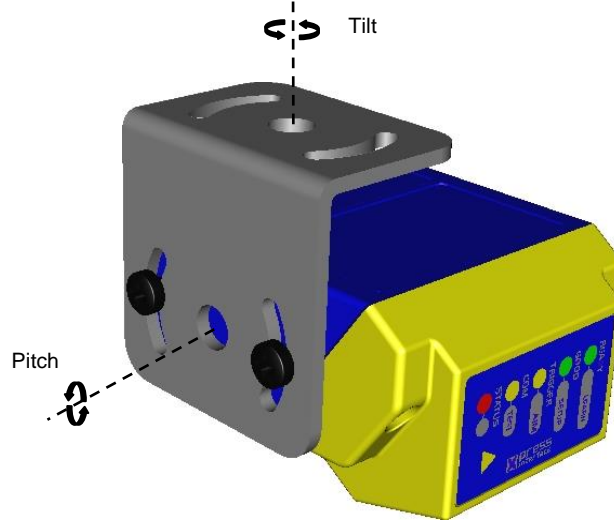

Figure 30 –90° Model with ST-337 Mounting Bracket - Internal Positioning

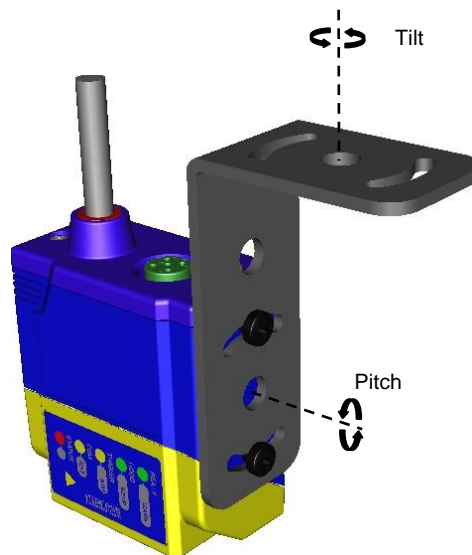

Figure 31 –Straight Model with ST-336 Mounting Bracket - Internal Positioning

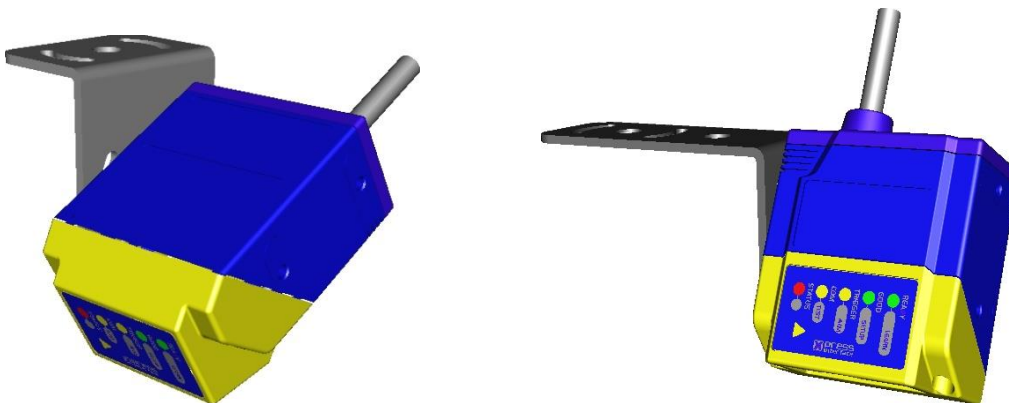

Figure 32 –Mounting Bracket External Positioning

Matrix 210™ is able to decode code labels at a variety of angles, however significant angular distortion may degrade reading performance.

When mounting Matrix 210™, take into consideration these **ideal** label position angles: **Pitch or Skew 10° to 20° and Tilt 0°.**

Note: Since Matrix 210™ is omni-directional on the code plane, the Pitch and Skew angles have the same significance with respect to the code plane. However in some advanced code reading applications performance can be improved by modifying the Pitch angle.

Follow the suggestions below for the best orientation:

The **Pitch and Skew** angles are represented by the values **P** and **S** in Figure 33 and in Figure 34. Position the reader in order to avoid the direct reflection of the light emitted by the Matrix 210™ reader; it is advised to **assure at least 10°** for one of these angles. In some cases, such as low contrast or low illumination, it can be useful to use a **Pitch or Skew** angle = 0°.

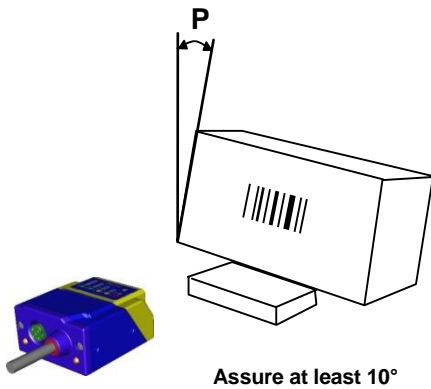

Figure 33 - Pitch angle

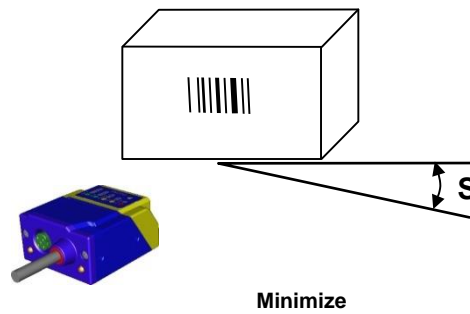

Figure 34 - Skew angle

The **Tilt** angle is represented by the value **T** in Figure 35. Matrix 210™ can read labels with any tilt angle.

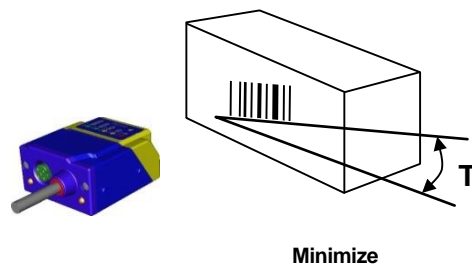

Figure 35 - Tilt angle

See chp. 6 for FOV and Reading Distance considerations.

4 CBX ELECTRICAL CONNECTIONS

All Matrix 210™ 25-pin models can be directly connected to a CBX connection box.

We recommend making system connections through one of the CBX connection boxes since they offer the advantages of easy connection, easy device replacement and filtered reference signals.



NOTE: If you require direct wiring to the reader the details of the connector pins and relative connections are indicated in Appendix A.

The table below gives the pinout of the CBX100/500 terminal block connectors. Use this pinout when the Matrix 210™ reader is connected by means of the CBX100/500:

CBX100/500 Terminal Block Connectors			
Input Power			
Vdc	Power Supply Input Voltage +		
GND	Power Supply Input Voltage -		
Earth	Protection Earth Ground		
Inputs			
+V	Power Source – External Trigger		
I1A	External Trigger A (polarity insensitive)		
I1B	External Trigger B (polarity insensitive)		
-V	Power Reference – External Trigger		
+V	Power Source – Inputs		
I2A	Input 2 A (polarity insensitive)		
I2B	Input 2 B (polarity insensitive)		
-V	Power Reference – Inputs		
Outputs			
+V	Power Source - Outputs		
-V	Power Reference - Outputs		
O1+	Output 1 +		
O1-	Output 1 -		
O2+	Output 2 +		
O2-	Output 2 -		
Auxiliary Interface			
TX	Auxiliary Interface TX		
RX	Auxiliary Interface RX		
SGND	Auxiliary Interface Reference		
ID-NET™			
REF	Network Reference		
ID+	ID-NET™ network +		
ID-	ID-NET™ network -		
Shield	Network Cable Shield		
Main Interface			
	RS232	RS485 Full-Duplex	RS485 Half-Duplex
	TX	TX+	RTX+
	RX	*RX+	
	RTS	TX-	RTX-
	CTS	*RX-	
	SGND	SGND	SGND

* Do not leave floating, see par. 4.2.2 for connection details.



NOTE: To avoid electromagnetic interference when the reader is connected to a CBX connection box, verify the jumper positions in the CBX as indicated in its Installation Manual.

4.1 POWER SUPPLY

Power can be supplied to the reader through the CBX100/500 spring clamp terminal pins as shown in Figure 36:

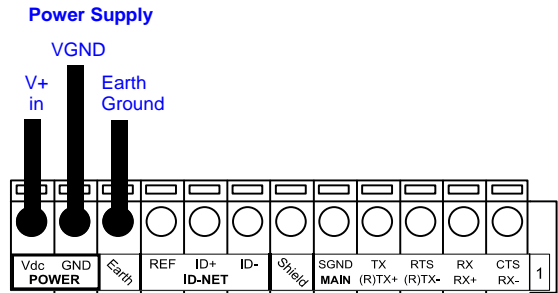

Figure 36 - Power Supply Connections

The power must be between 10 and 30 Vdc only.

It is recommended to connect the device CHASSIS to earth ground (Earth) by setting the appropriate jumper in the CBX connection box. See the CBX Installation Manual for details.

4.2 MAIN SERIAL INTERFACE



CAUTION: Do not connect to the Main Interface spring clamp terminals if using Host Interface Modules (Fieldbus) with the CBX500.

The signals relative to the following serial interface types are available on the CBX spring clamp terminal blocks.

The main serial interface type and its parameters (baud rate, data bits, etc.) can be defined by the user via VisiSet™ software. The RS485 half duplex is automatically set whenever MUX32 communication protocol is enabled. For more details refer to the "Communication" folder in the VisiSet™ Help On Line.

Details regarding the connections and use of the interfaces are given in the next paragraphs.

4.2.1 RS232 Interface

The RS232 interface can be used for Point-to-Point, Pass Through or Master/Slave connections. When it is connected to the host computer it allows both transmission of code data and reader configuration by VisiSet™.

The following pins are used for RS232 interface connection:

CBX100/500	Function
TX	Transmit Data
RX	Receive Data
RTS	Request To Send
CTS	Clear To Send
SGND	Signal Ground

It is always advisable to use shielded cables. The overall maximum cable length must be less than 15 m (49.2 ft).

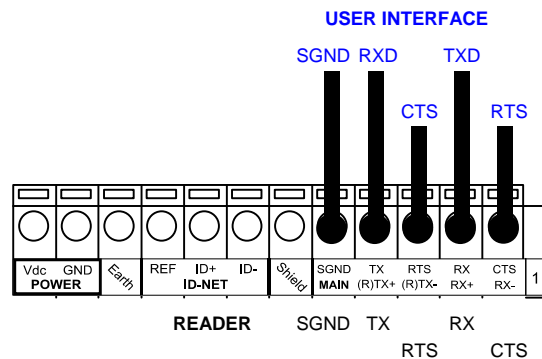

Figure 37 – RS232 Main Interface Connections Using Hardware Handshaking

The RTS and CTS signals control data transmission and synchronize the connected devices.

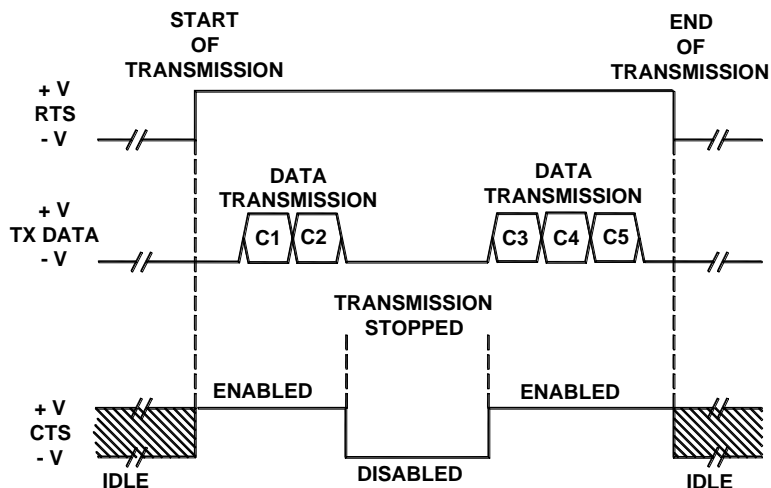

Figure 38 - RS232 Control Signals

If the RTS/CTS handshaking protocol is enabled, the Matrix 210™ activates the RTS output to indicate a message is to be transmitted. The receiving unit activates the CTS input to enable the transmission.

4.2.2 RS485 Full-Duplex Interface

The RS485 full-duplex (5 wires + shield) interface is used for non-pollled communication protocols in point-to-point connections over longer distances (max 1200 m / 3940 ft) than those acceptable for RS232 communications or in electrically noisy environments.

The CBX pinout follows:

CBX100/500	Function
TX+	RS485 Transmit Data +
RX+	RS485 Receive Data +
TX-	RS485 Transmit Data -
RX-	RS485 Receive Data -
SGND	Signal Ground

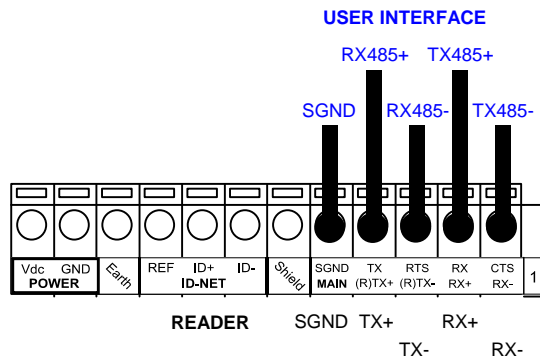

Figure 39 - RS485 Full-duplex Connections



NOTE: For applications that do not use RX485 signals, do not leave these lines floating but connect them to SGND as shown below.

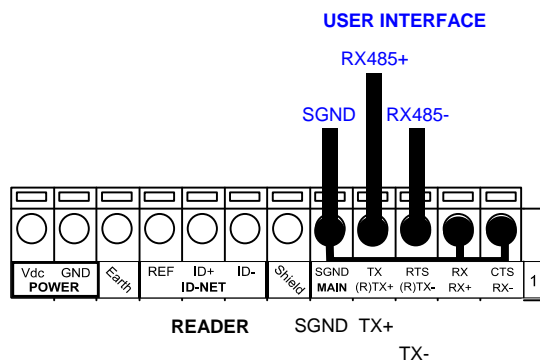

Figure 40 - RS485 Full-duplex Connections using Only TX Signals

4.2.3 RS485 Half-Duplex Interface



NOTE: This interface is provided for backward compatibility. We recommend using the more efficient ID-NET™ network for Master/Slave or Multiplexer layouts.

The RS485 half-duplex (3 wires + shield) interface is used for polled communication protocols.

It can be used for Multidrop connections with a Datalogic Multiplexer, (see par. **Error! Reference source not found.**) exploiting a proprietary protocol based on polled mode called MUX32 protocol, where a master device polls slave devices to collect data.

CBX100/500	Function
RTX+	RS485 Receive/Transmit Data +
RTX-	RS485 Receive/Transmit Data -
SGND	Signal Ground

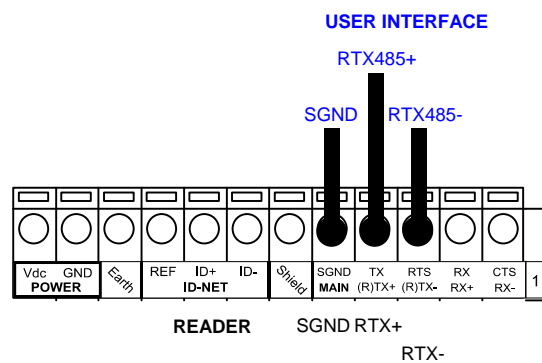

Figure 41 - RS485 Half-duplex Connections

This interface is forced by software when the protocol selected is MUX32 protocol.

In a Multiplexer layout, the Multidrop address must also be set via serial channel by the VisiSet™ utility or by the Host Programming Mode.

Figure 42 shows a multidrop configuration with Matrix 210™ readers connected to a Multiplexer.



CAUTION: This is an example of multidrop wiring. Consult the multiplexer manual for complete wiring instructions.

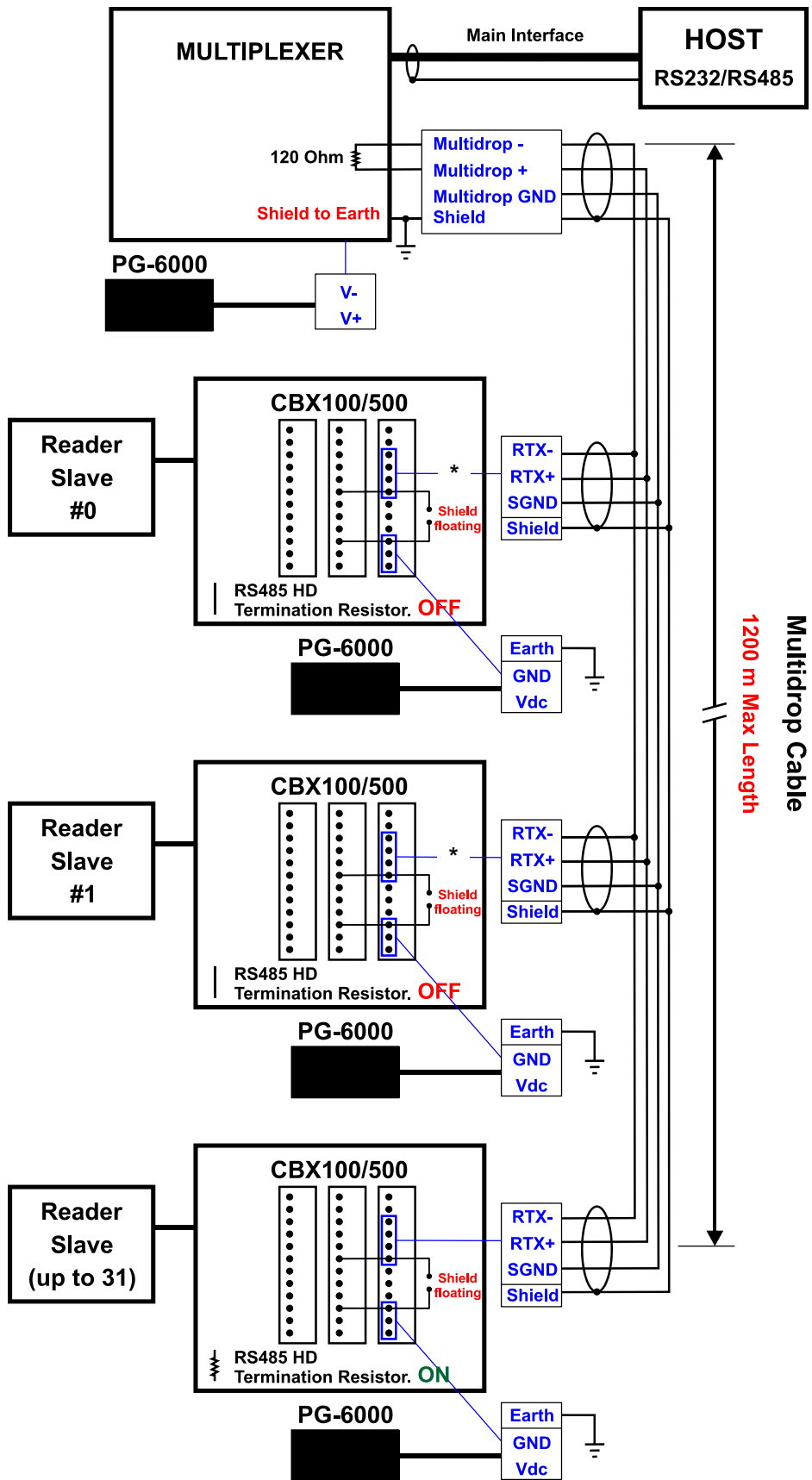

Figure 42 - Matrix 210™ Multidrop Connection to a Multiplexer

* When using CBX500, the **Main** interface multidrop network signals: **Shield**, **SGND**, **RTX+** and **RTX-** are repeated on terminal connector row 4 to facilitate system cabling.

4.3 ID-NET™ INTERFACE

CBX100/500	Function
Shield	Network Cable Shield
ID+	ID-NET™ network +
ID-	ID-NET™ network -
REF	Network Reference

4.3.1 ID-NET™ Cables

The following instructions are referred to Figure 44, Figure 45 and Figure 46.

- The general cable type specifications are: CAT5 twisted pair + additional CAT5 twisted pair, shielded cable AWG 24 (or AWG 22) stranded flexible.

We recommend using DeviceNet cables (drop or trunk type) to the following reference standards:

AN50325 – IEC 62026

UL STYLE 2502 80°C 30V

- Cable Shield MUST be connected to earth ground ONLY at the Master.
- NEVER use ID-NET™ cable shield as common reference.
- The ID-NET™ max cable length depends on the baudrate used, (see the Baudrate Table below).
- For Common Power Connections use only 2 wires (ID+ and ID-).
 - DC Voltage Power cable (Vdc – GND) should be handled as a signal cable (i.e. do not put it together with AC cable):
 - Wire dimensioning must be checked in order to avoid voltage drops greater than 0.8 Volts.
 - Cable should lie down as near as possible to the ID-NET™ cable (avoiding wide loops between them).
- Reader's chassis may be connected to earth.
- Network inside the same building.

Baudrate Table				
Baud Rate	125 kbps	250 kbps	500 kbps	1Mbps
Cable Length	1200 m	900 m	700 m	*

* Application dependent, contact your Datalogic Automation representative for details.



NOTE: The default ID-NET™ baudrate is 500 kbps. Lower ID-NET™ baudrates allow longer cable lengths. The baudrate is software configurable by authorized Datalogic Automation personnel only.

4.3.2 ID-NET™ Response Time

The following figure shows the response time of the ID-NET™ network. This time is defined as the period between the Trigger activation and the beginning of data transmission to the Host.

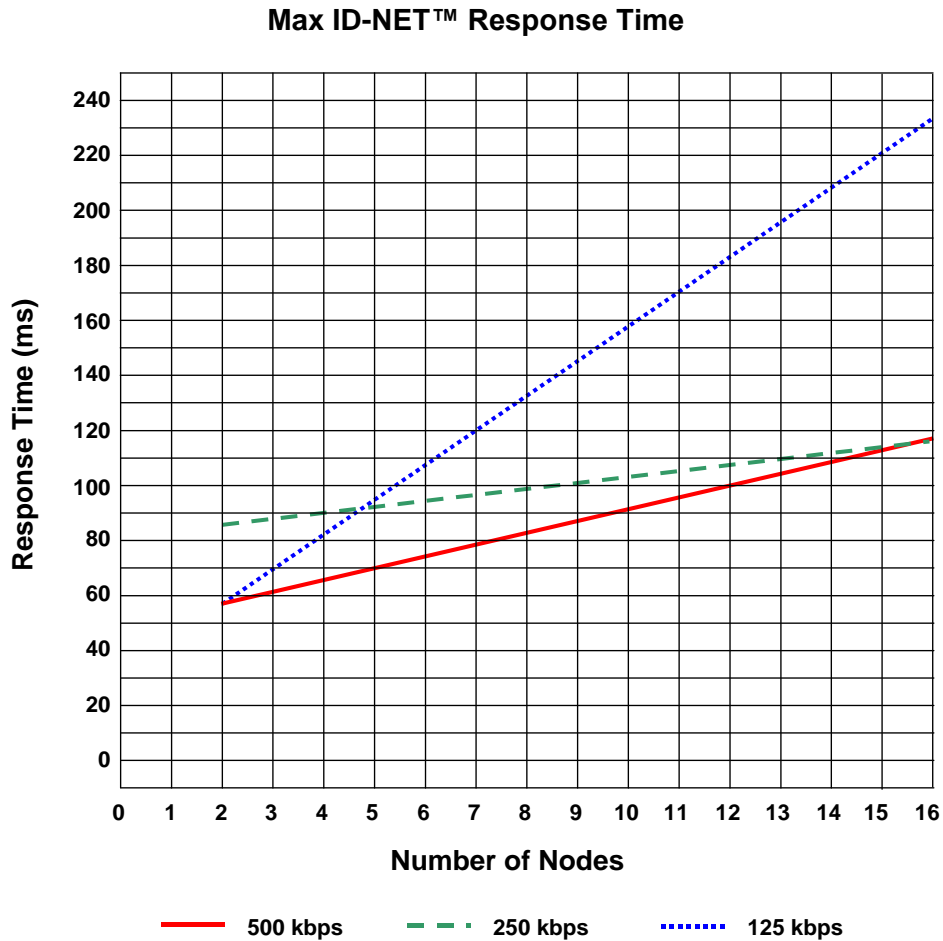

Figure 43 – ID-NET™ Response Time

CONDITIONS:

- ID-NET™ M/S Synchronized layout
- message length = 50 bytes per node

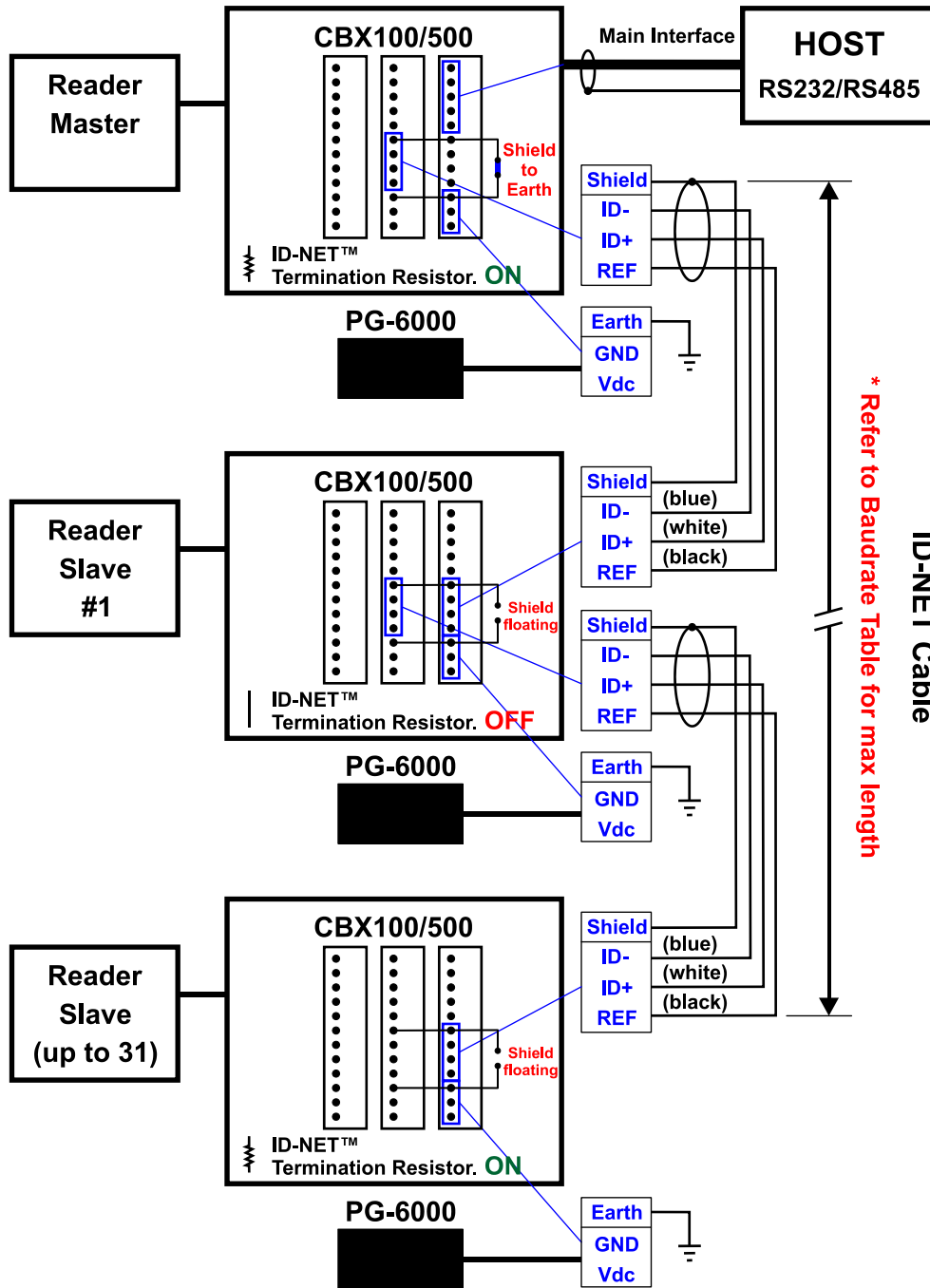

Figure 44 – ID-NET™ Network Connections with isolated power blocks

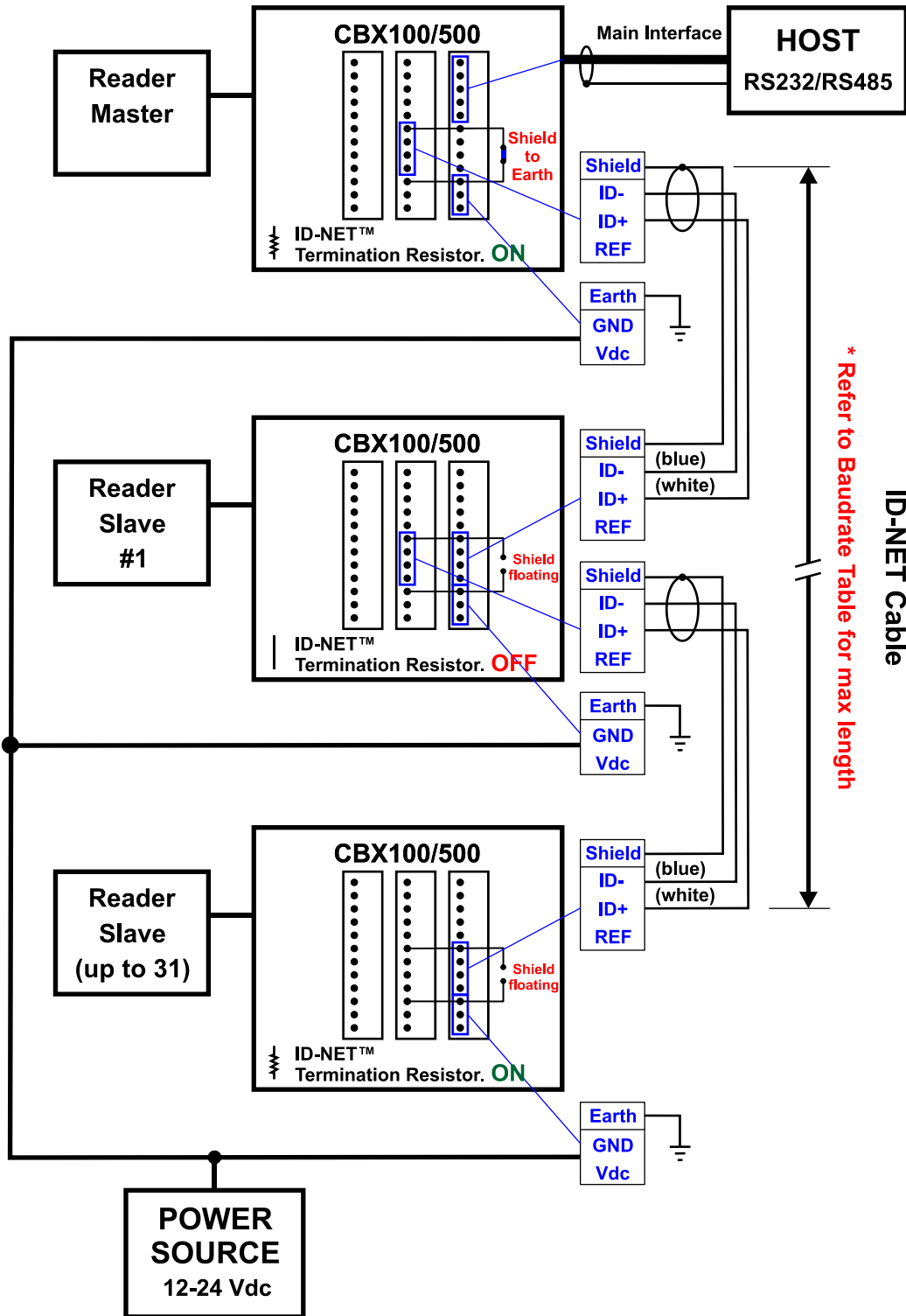

Figure 45 - ID-NET™ Network Connections with Common Power Branch Network

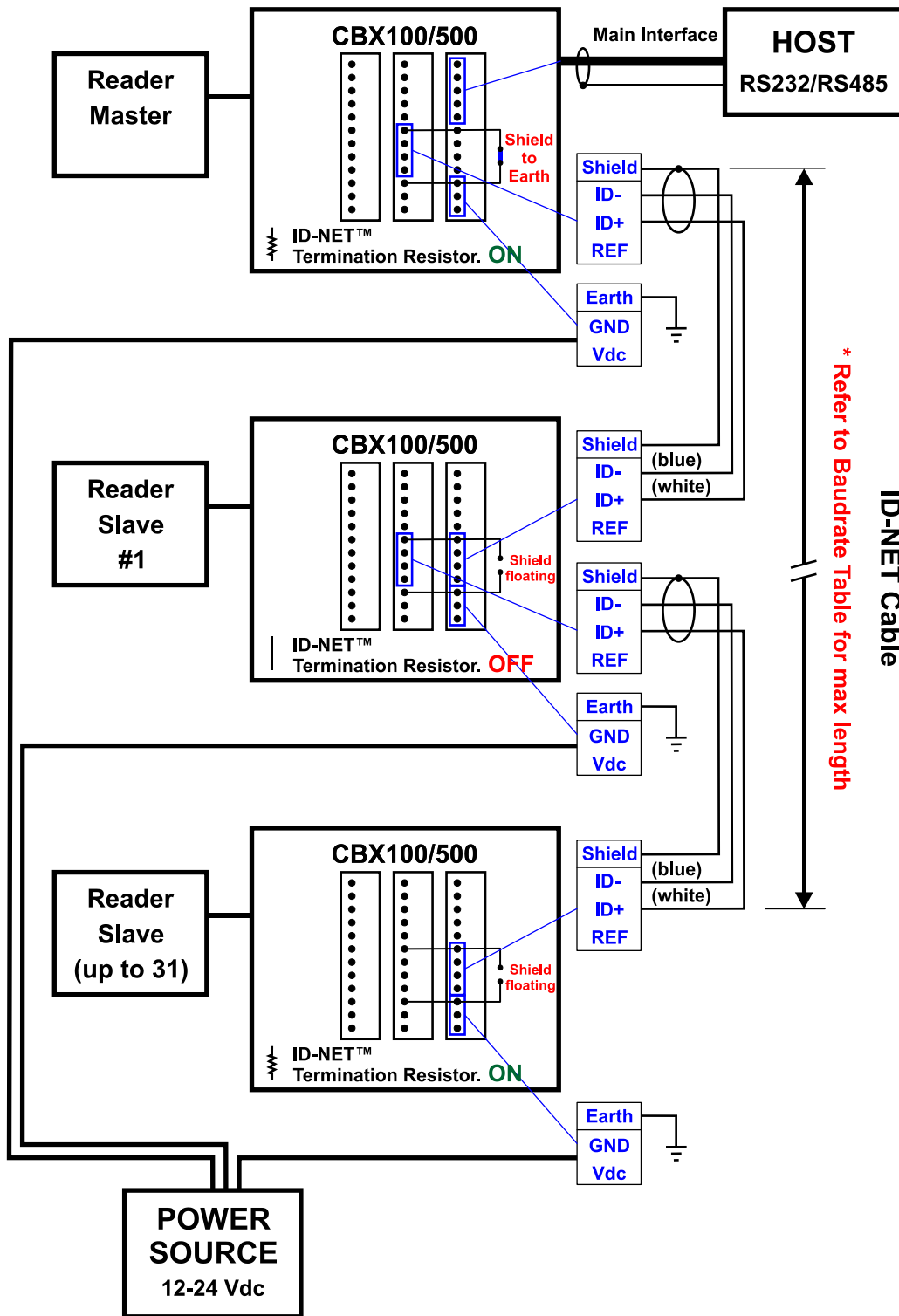

Figure 46 – ID-NET™ Network Connections with Common Power Star Network

4.3.3 ID-NET™ Network Termination

The network must be properly terminated in the first and last reader of the network. This is done by setting the ID-NET™ Termination Resistance Switch in the CBX100/500 to ON.

4.4 AUXILIARY RS232 INTERFACE

The RS232 auxiliary interface is available for Point-to-Point, Pass Through or Master/Slave connections. When it is connected to the host computer it allows both transmission of code data and reader configuration by VisiSet™.

The parameters relative to the aux interface (baud rate, data bits, etc.) as well as particular communication modes such as LOCAL ECHO can be defined through the Communication folder of the VisiSet™ utility program.

The 9-pin female Auxiliary Interface connector inside the CBX is the preferred connector for device configuration or communication monitoring.

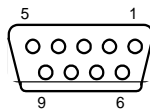

Figure 47 - 9-pin female connector

If permanent system wiring is required, the following pins are used to connect the RS232 auxiliary interface:

CBX100/500	Function
RX	Auxiliary Interface Receive Data
TX	Auxiliary Interface Transmit Data
SGND	Auxiliary Interface Reference

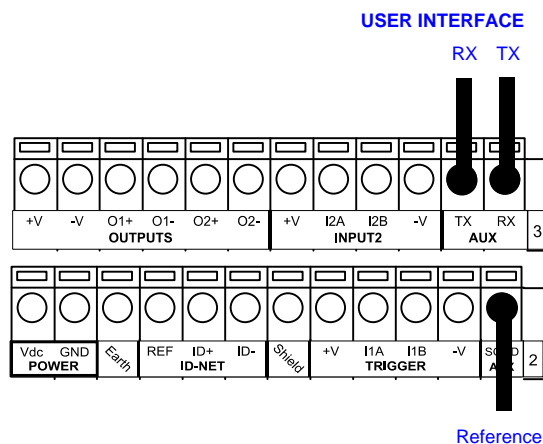

Figure 48 - RS232 Auxiliary Interface Connections



NOTE: Do not connect the Aux Interface to the CBX spring clamp connectors and the 9-pin connector simultaneously.

4.5 INPUTS

There are two optocoupled polarity insensitive inputs available on the reader: Input 1 (External Trigger) and Input 2, a generic input:

The External Trigger can be used in One Shot Mode or in Phase Mode. Its main functions are:

- acquisition trigger in One Shot Mode
- reading phase-ON/reading phase-OFF command in Phase Mode

The main functions of the general purpose Input 2 are:

- second external trigger in Phase Mode
- match code storage command when the Match Code option is enabled

The electrical features of both inputs are:

$$V_{AB} = 30 \text{ Vdc max.}$$

$$I_{IN} = 12 \text{ mA (reader) + 12 mA (CBX) max.}$$

The active state of these inputs are selected in software. Refer to the VisiSet™ Help On Line.

An anti-disturbance filter is implemented in software on both inputs so that the minimum pulse duration is $\cong 0.5$ milliseconds. This value can be increased through the software parameter Debounce Filter, see the Digital I/O folder in the VisiSet™ Help On Line for further details.

These inputs are optocoupled and can be driven by both NPN and PNP type commands.



NOTE: Polarity insensitive inputs assure full functionality even if pins A and B are exchanged.

The connections are indicated in the following diagrams:

CBX100/500	Function
+V	Power Source - External Trigger
I1A	External Trigger A (polarity insensitive)
I1B	External Trigger B (polarity insensitive)
-V	Power Reference - External Trigger

The yellow Trigger LED (Figure 14, 5) is on when the active state of the External Trigger corresponds to ON.

EXTERNAL TRIGGER INPUT CONNECTIONS USING MATRIX 210™ POWER



CAUTION: Power is available directly to the Input Device, independently from the Power Supply Switch inside the CBX.

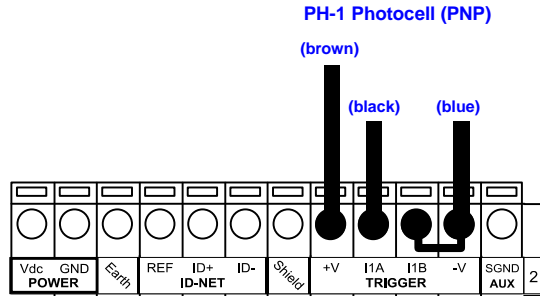

Figure 49 – PH-1 External Trigger Using Matrix 210™ Power

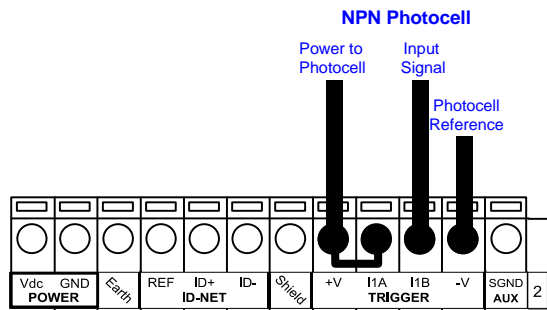

Figure 50 - NPN External Trigger Using Matrix 210™ Power

EXTERNAL TRIGGER INPUT CONNECTIONS USING EXTERNAL POWER

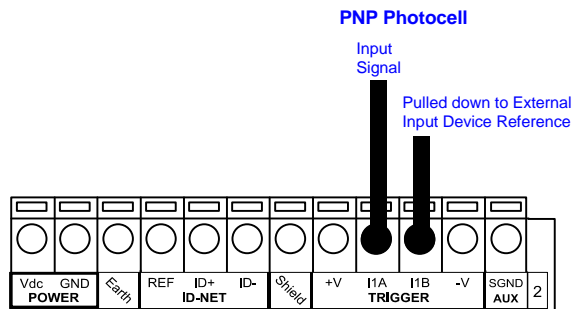

Figure 51 - PNP External Trigger Using External Power

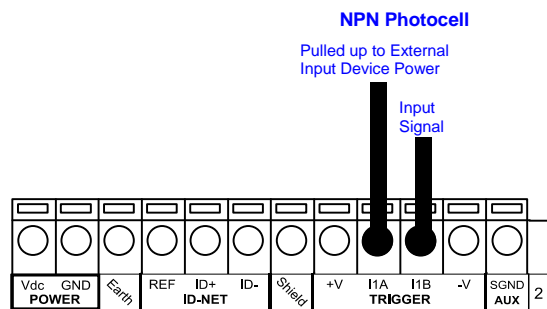

Figure 52 - NPN External Trigger Using External Power

CBX100/500	Function
+V	Power Source - Inputs
I2A	Input 2 A (polarity insensitive)
I2B	Input 2 B (polarity insensitive)
-V	Power Reference - Inputs

INPUT 2 CONNECTIONS USING MATRIX 210™ POWER



CAUTION: Power is available directly to the Input Device, independently from the Power Supply Switch inside the CBX.

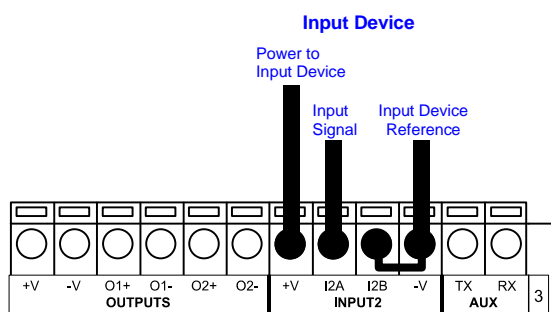

PNP Input 2 Using Matrix 210™ Power

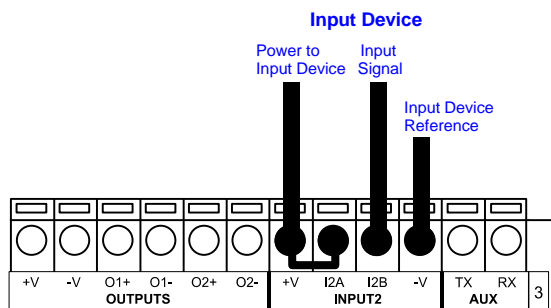

NPN Input 2 Using Matrix 210™ Power

INPUT 2 CONNECTIONS USING EXTERNAL POWER

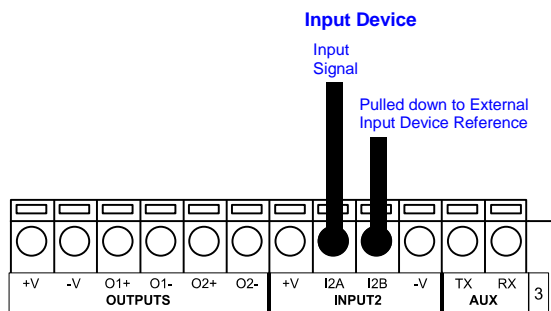

Figure 53 - PNP Input 2 Using External Power

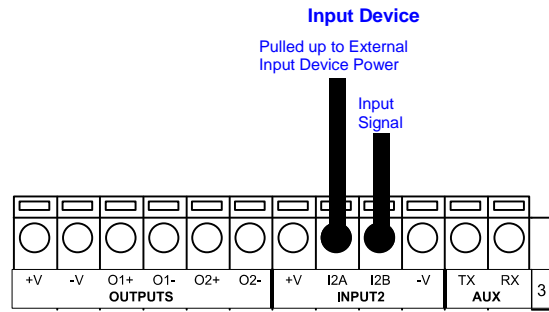

Figure 54 - NPN Input 2 Using External Power

4.6 OUTPUTS

Two optocoupled general purpose outputs are available. The meaning of the two outputs Output 1 and Output 2 can be defined by the user. They are typically used either to signal the data collection result or to control an external lighting system.

CBX100/500	Function
+V	Power Source - Outputs
O1+	Output 1 +
O1-	Output 1 -
O2+	Output 2 +
O2-	Output 2 -
-V	Power Reference Outputs

The electrical features of the two outputs are the following:

$$V_{CE} = 30 \text{ Vdc max.}$$

$$I_{CE} = 40 \text{ mA continuous max.; 130 mA pulsed max.}$$

By default, Output 1 is associated with the Partial Read and No Read events, which activates when the code(s) signaled by the external trigger are not decoded, and Output 2 is associated with the Complete Read event, which activates when all the selected codes are correctly decoded.

The output signals are fully programmable being determined by the configured Activation/Deactivation events, Deactivation Timeout or a combination of the two. Refer to the Digital I/O folder in the VisiSet™ Help On Line for further details.

OUTPUT CONNECTIONS USING MATRIX 210™ POWER



CAUTION: Power is available directly to the Output Device, independently from the Power Supply Switch inside the CBX.

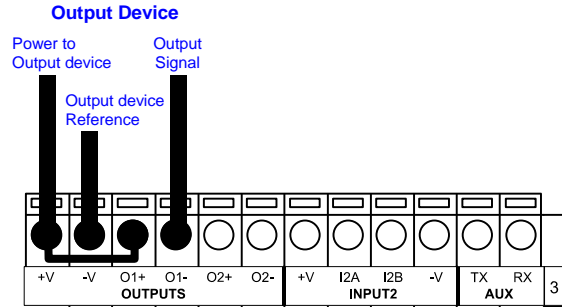

Figure 55 - Open Emitter Output Using Matrix 210™ Power

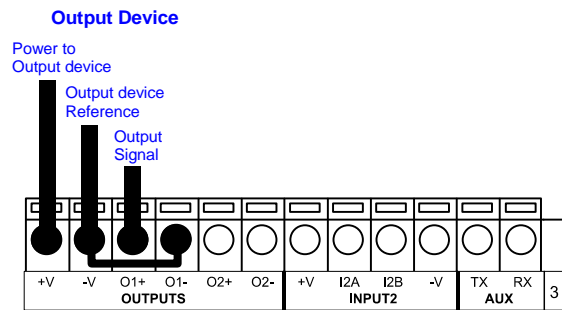

Figure 56 - Open Collector Output Using Matrix 210™ Power

OUTPUT CONNECTIONS USING EXTERNAL POWER

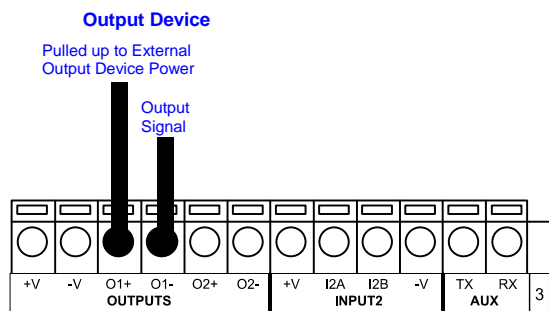

Figure 57 - Output Open Emitter Using External Power

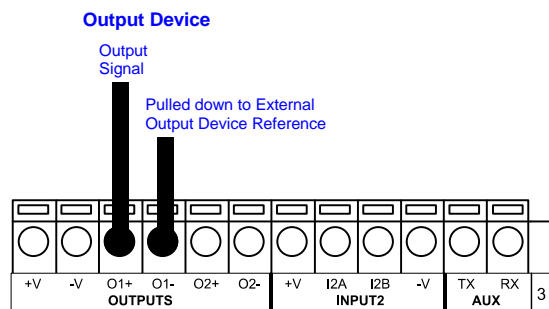

Figure 58 - Output Open Collector Using External Power

4.7 EXTERNAL LIGHTING SYSTEMS

If an External Illuminator is used, it can be powered from the CBX connection box. It must be connected to the **Vdc** and **GND** terminal clamps.



CAUTION: Power is available directly to the Illuminator, independently from the Power Supply Switch inside the CBX.

In the case of the LT-700 illuminator, one of the available digital outputs must be connected as the control signal. In VisiSet™, configure the Output Line Function parameter to "External Lighting System" and the Matrix Output x External Lighting System Mode parameter to "Triggered".

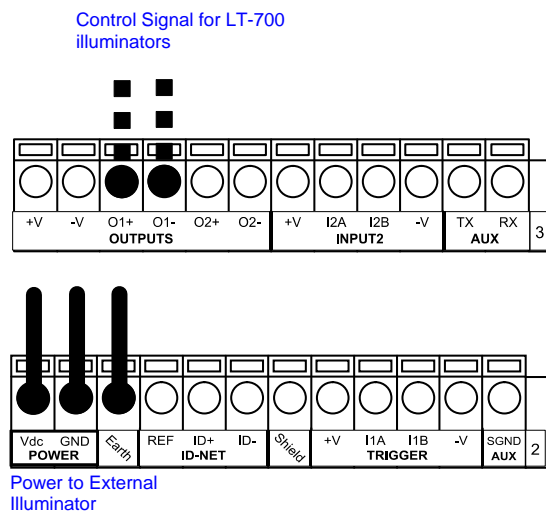

Figure 59 – External Lighting System Connections

Below is a table summarizing the External Illuminator wiring and power requirements:

Illuminator	Wire Color	CBX/Matrix Signal	Meaning
LT-700	Red	Vdc	10 to 30 Vdc
	Black	GND	Ground
	White	Earth	Shield/Earth Ground
	Green	O1- or O2-	Control Signal -
	Yellow	O1+ or O2+	Control Signal +

4.8 ON-BOARD ETHERNET INTERFACE (Matrix 210 2xx-x1x models only)

The on-board Ethernet Interface can be used for TCP/IP communication with a remote or local host computer by connecting the reader to either a LAN or directly to a host PC. There is no need to use a crossover adapter since Matrix 210™ incorporates an auto-cross function.

A **CAB-ETH-M0x** cable can be used to connect to a LAN.

On the Matrix 210™ Ethernet interface the following communication channels are available:

- Data Socket
- Image Socket
- WebSentinel Socket
- Image FTP Client
- HTTP Server
- EtherNet/IP
- Profinet IO
- Modbus TCP

For further details refer to the Ethernet Folder in the VisiSet™ Help On Line and to the "Matrix Ethernet Service Guide.pdf" document provided as supplementary documentation.

4.9 USER INTERFACE - HOST

The following table contains the pinout for standard RS232 PC Host interface. For other user interface types please refer to their own manual.

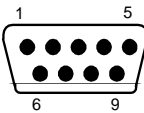
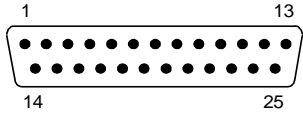
RS232 PC-side connections			
 <p>9-pin male connector</p>		 <p>25-pin male connector</p>	
Pin	Name	Pin	Name
2	RX	3	RX
3	TX	2	TX
5	GND	7	GND
7	RTS	4	RTS
8	CTS	5	CTS

5 TYPICAL LAYOUTS

The following typical layouts refer to system hardware configurations. However, they also require the correct setup of the software configuration parameters. Dotted lines in the figures refer to optional hardware configurations within the particular layout.

5.1 POINT-TO-POINT

5.1.1 Serial Host (2xx-x0x and 2xx-x1x models)

In this layout the data is transmitted to the Host on the main serial interface. The RS232 auxiliary interface can be used for reader configuration by connecting a laptop computer running VisiSet™. Host Mode programming can be accomplished either through the main interface or the Auxiliary interface.

In Local Echo communication mode, data is transmitted on the RS232 auxiliary interface independently from the main interface selection.

When One Shot or Phase Mode operating mode is used, the reader can be activated by an External Trigger (for example a pulse from a photoelectric sensor) when the object enters its reading zone.

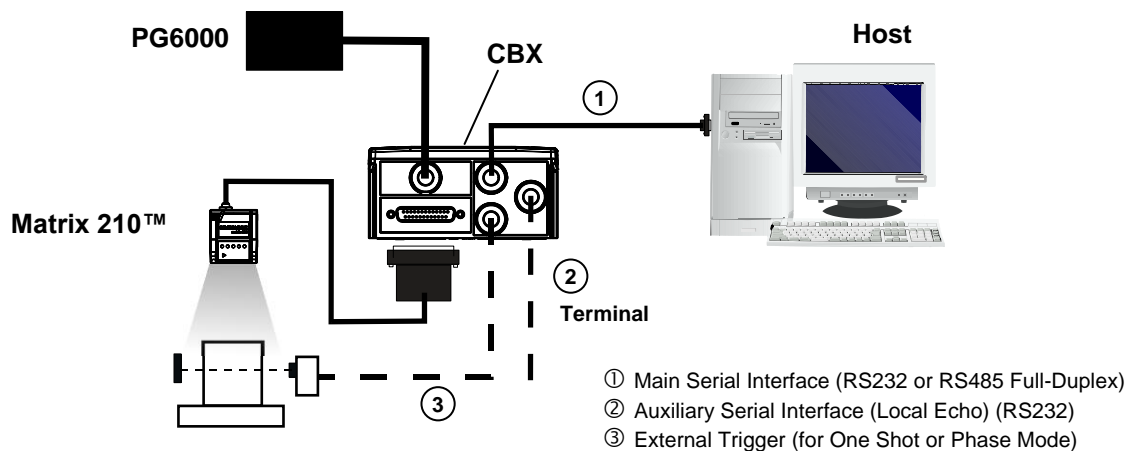

Figure 60 – Serial Interface Point-to-Point Layout

5.1.2 Embedded (On-Board) Ethernet (2xx-x1x models only)

"In a Point-to-Point layout the reader is connected to a local host by using a **CAB-ETH-M0x** cable. There is no need to use a crossover adapter since Matrix 210™ incorporates an auto-cross function.

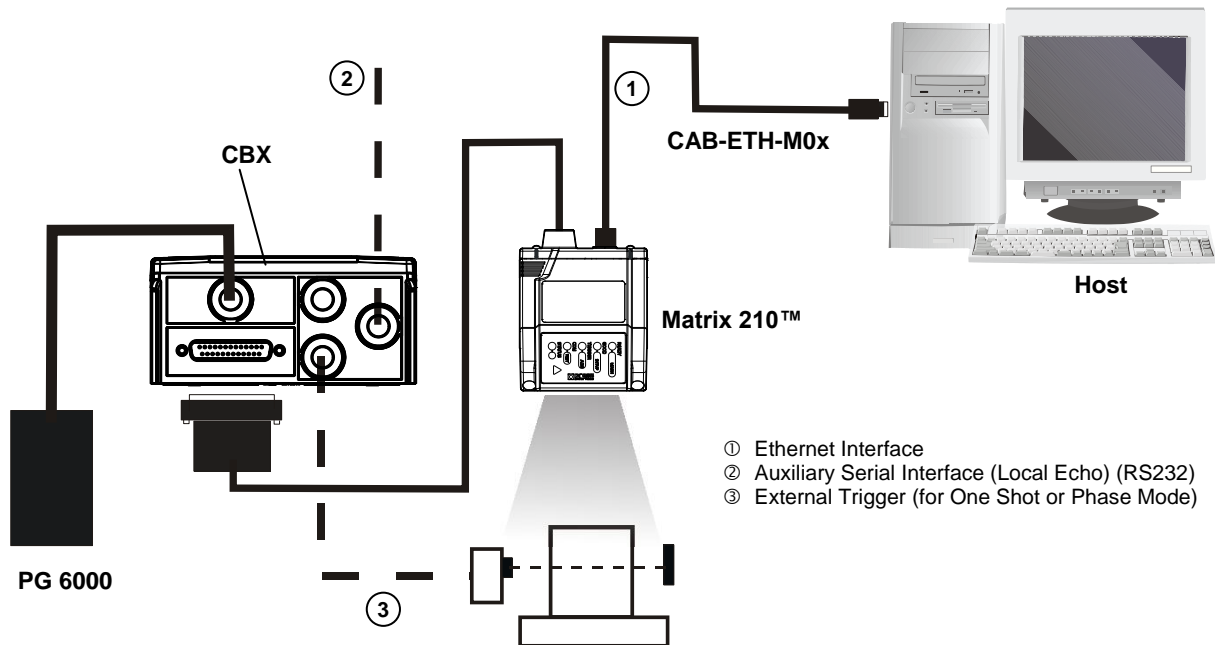

Figure 61 - Ethernet Point-to-Point Layout

In this layout, before proceeding with the connection, it is necessary to configure the reader Ethernet parameters via VisiSet™. For further details, see "Configuration Through Ethernet" and the Ethernet Folder in the VisiSet™ Help On Line.

5.1.3 TCP/IP Ethernet (BM2x0)

In this layout the data is transmitted to the Host on the TCP/IP Ethernet interface (CBX500 with BM200/210 Host Interface Module installed). The RS232 auxiliary interface can be used for reader configuration by connecting a laptop computer running VisiSet™. Host Mode programming can be accomplished either through the TCP/IP Ethernet interface or the Auxiliary interface.

In Local Echo communication mode, data is transmitted on the RS232 auxiliary interface independently from the TCP/IP Ethernet selection.

When One Shot or Phase Mode operating mode is used, the reader can be activated by an External Trigger (for example a pulse from a photoelectric sensor) when the object enters its reading zone.

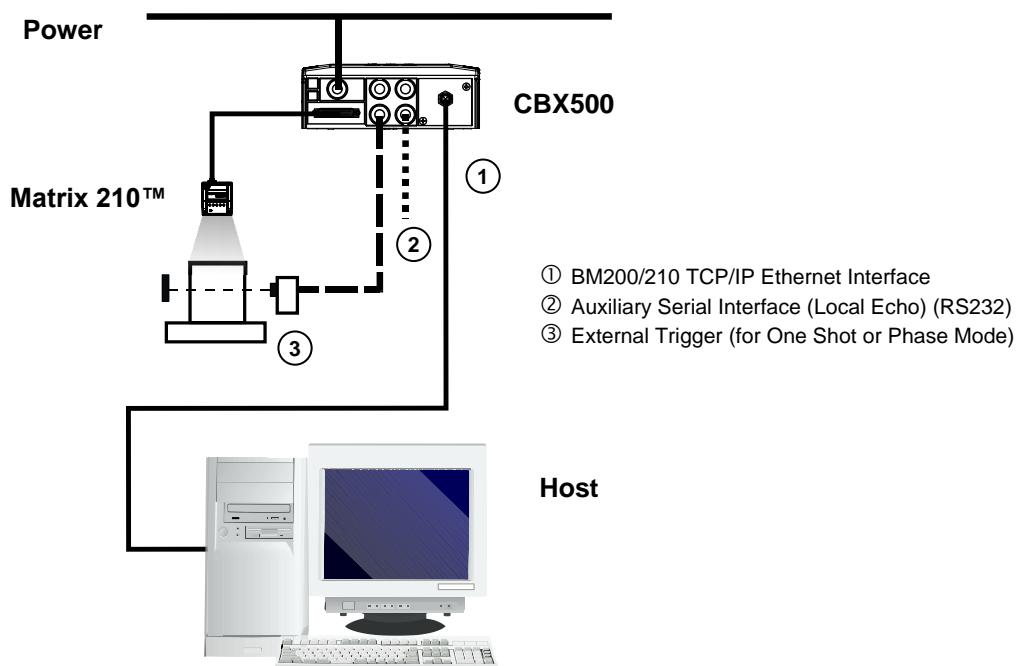

Figure 62 – BM200/210 TCP/IP Ethernet Interface Point-to-Point Layout

5.1.4 Fieldbus

In this layout a single scanner functions as a Slave node on a Fieldbus network. The data is transmitted to the Host through an accessory Fieldbus interface board installed inside the CBX500 connection box.

Reader configuration can be accomplished through the Auxiliary interface using the VisiSet™ configuration program or Host Mode programming.

In Local Echo communication mode, data is transmitted on the RS232 auxiliary interface independently from the Fieldbus interface selection.

When One Shot or Phase Mode operating mode is used, the reader can be activated by an External Trigger (photoelectric sensor) when the object enters its reading zone.

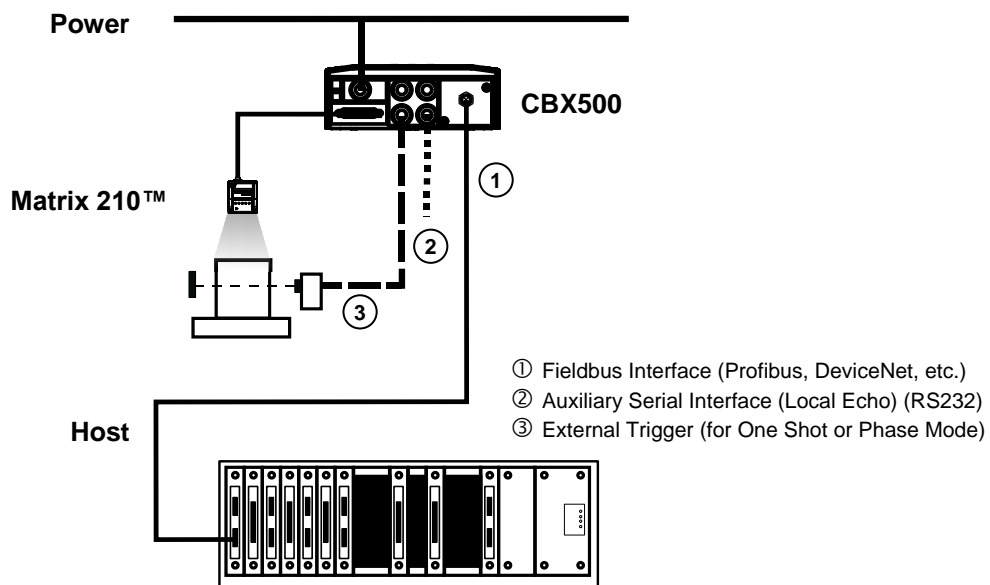

Figure 63 – Fieldbus Interface Point-to-Point Layout

5.2 ETHERNET NETWORKS

5.2.1 External Trigger Ethernet Host (2xx-x1x models only)

In this layout, before proceeding with the connection, it is necessary to configure the reader Ethernet parameters via VisiSet™. For further details, see “Configuration Through Ethernet” and the Ethernet Folder in the VisiSet™ Help On Line.

When using a Local Area Network (LAN), one or more Matrix 210 2xx-x1x can be connected to the network by using **CAB-ETH-M0x** cables. In the example below an External Trigger is used which is connected through a CBX connection box.

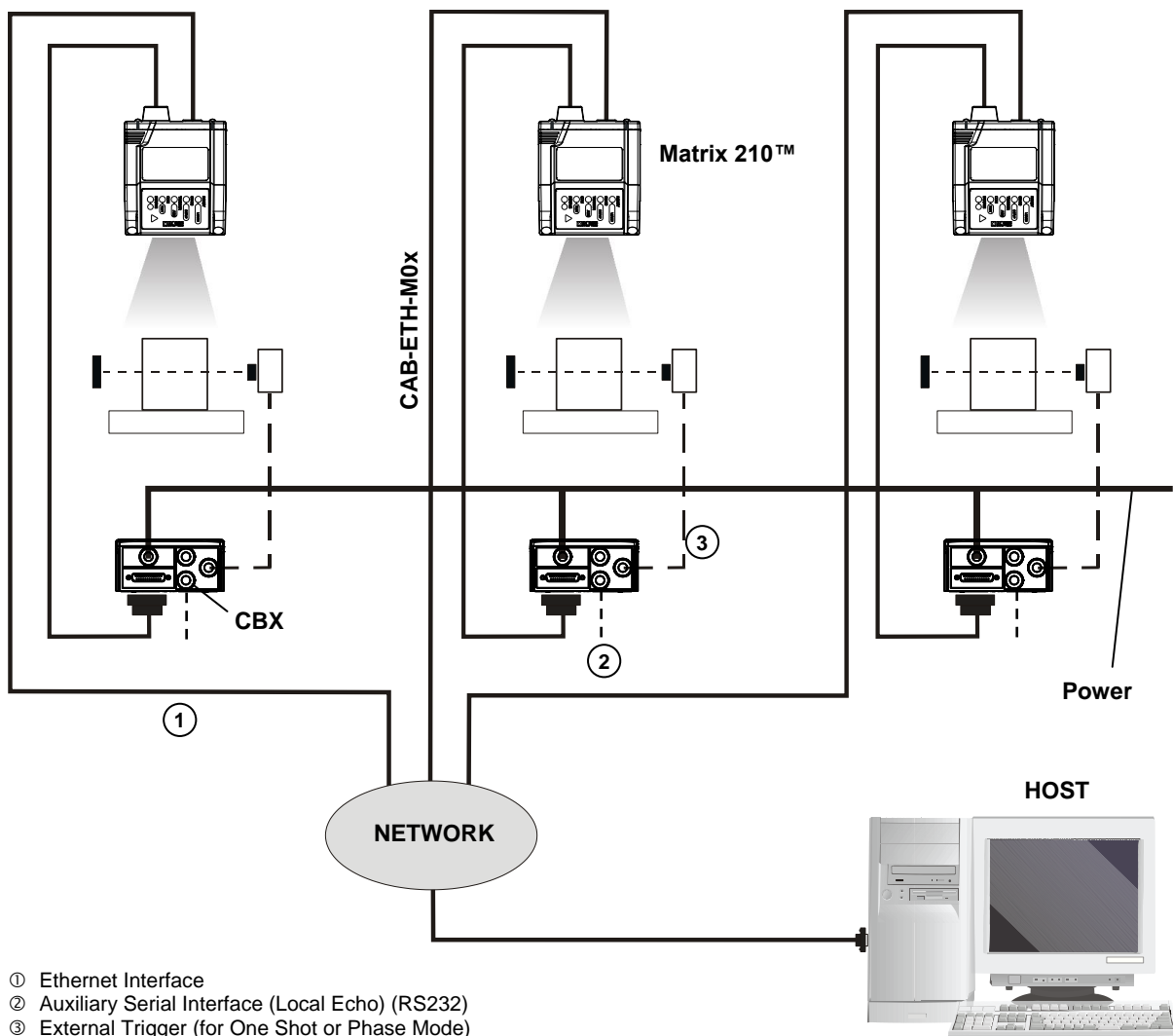

Figure 64 - Ethernet Network Layout

5.3 ID-NET™ SYNCHRONIZED NETWORK (2xx-x0x and 2xx-x1x models)

5.3.1 M/S Synchronized Serial Host

The ID-NET™ connection is used to collect data from several readers to build a multi-point or a multi-sided reading system; there can be one master and up to 31 slaves connected together.

The slave readers are connected together using the ID-NET™ interface. Every slave reader must have an ID-NET™ address in the range 1-31.

The master reader is also connected to the Host on the RS232/RS485 main serial interface.

For a Master/Slave Synchronized layout the External Trigger signal is unique to the system; there is a single reading phase and a single message from the master reader to the Host computer. **It is not necessary to bring the External Trigger signal to all the readers.**

In the Master/Slave Synchronized layout the Master operating mode can only be set to Phase Mode.

The main, auxiliary, and ID-NET™ interfaces are connected as shown in the figure below.

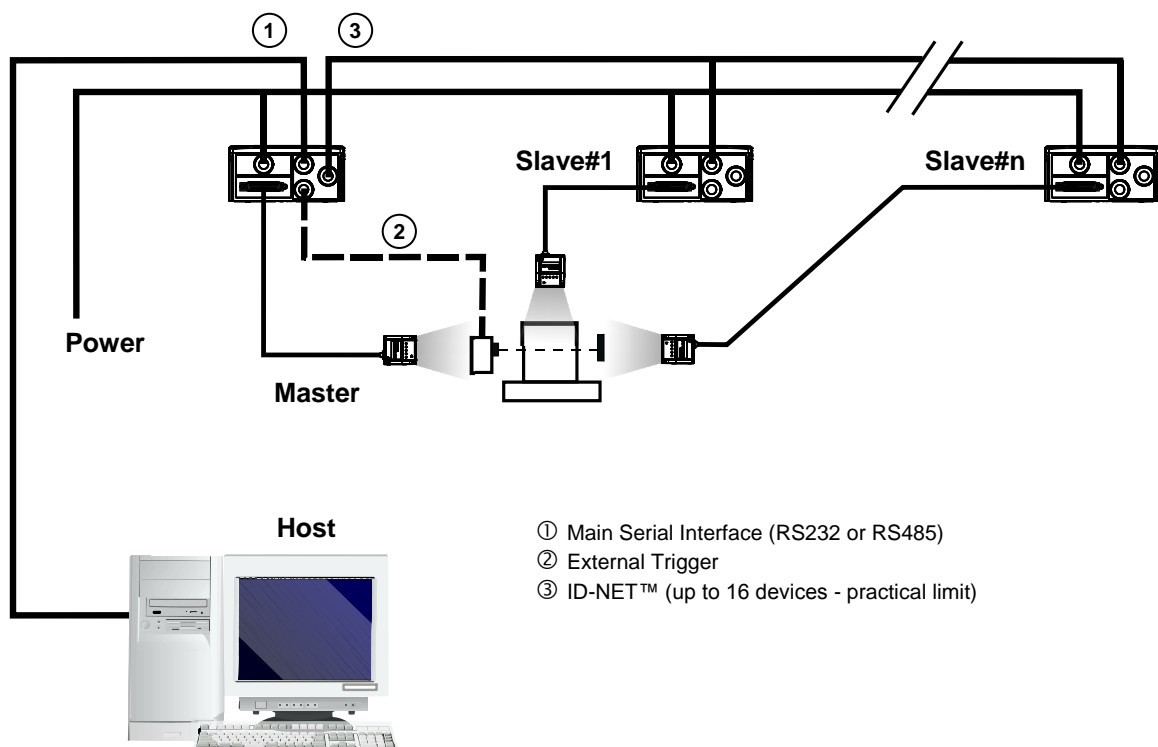

Figure 65 – ID-NET™ Synchronized Layout

The Master reader can be connected to the CBX series connection box (CBX + BM100 module) or to a QL500 having sw version 2.02.01 and later, with the advantage of the Backup and Restore configuration function.

If the Backup and Restore function is not required, then a QL300 or QL500 can be used to connect the master reader.

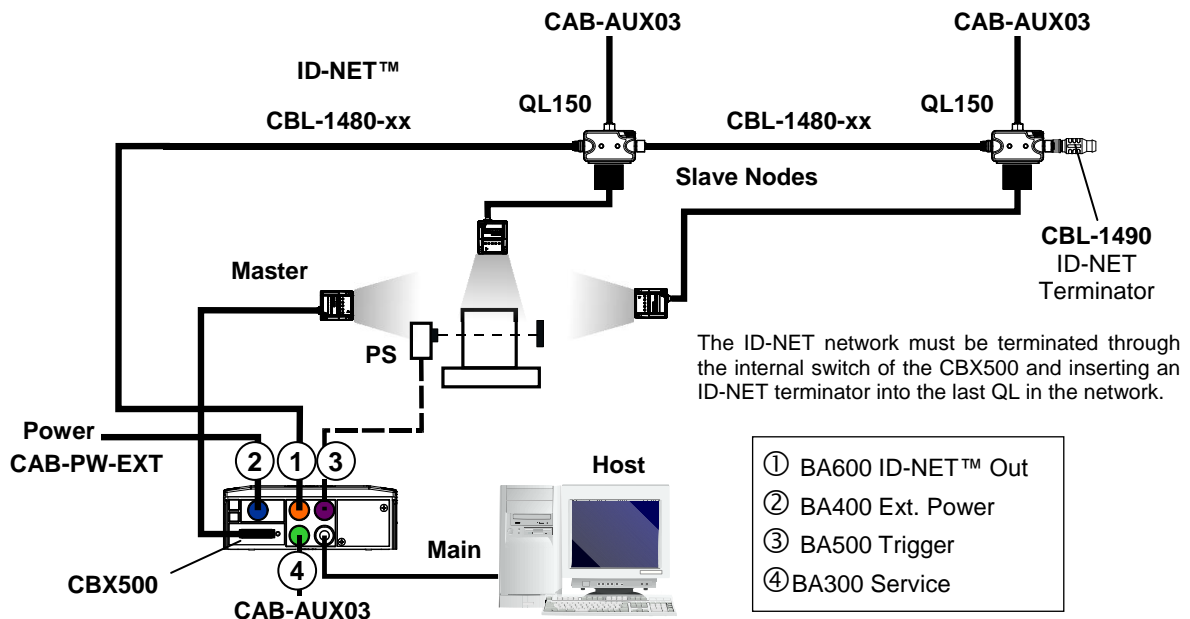

Figure 66 - ID-NET™ Synchronized Layout
Matrix 210™ Master with CBX500 + Matrix 210™ Slaves with QL150

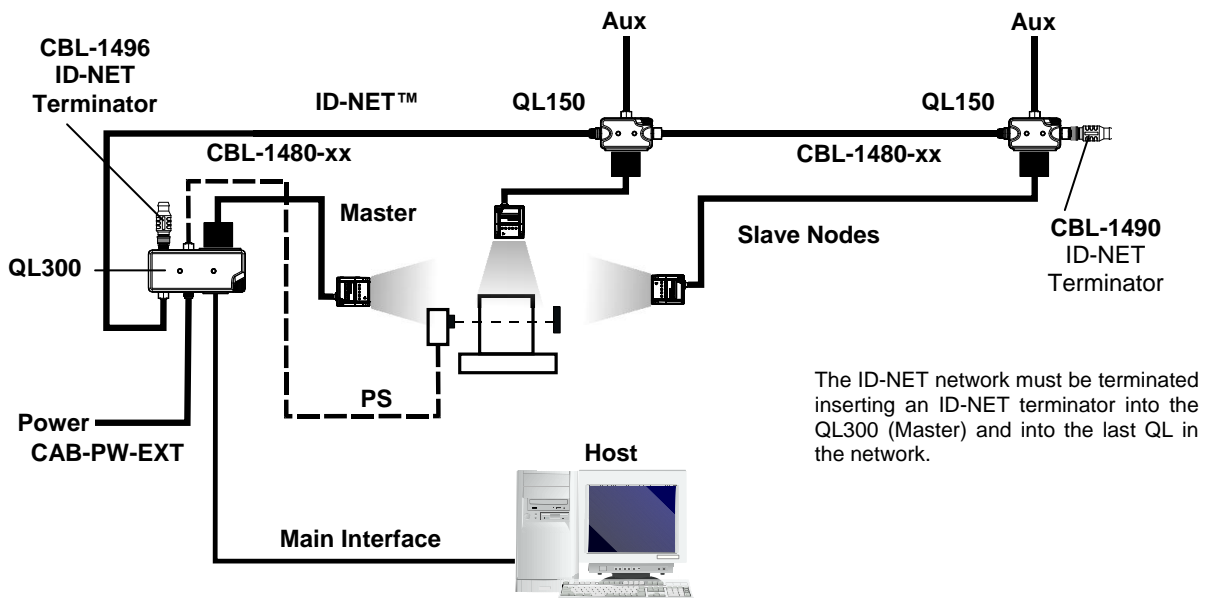

Figure 67 - ID-NET™ Synchronized Layout with QL300 Serial Interface to Host

5.3.2 M/S Synchronized TCP/IP Host

The same configuration can be made to a Host using a TCP/IP Ethernet interface. In this case the Master is connected to a CBX500 with BM200/210 Host Interface Module installed.

The TCP/IP Ethernet, auxiliary, and ID-NET™ interfaces are connected as shown in the figure below.

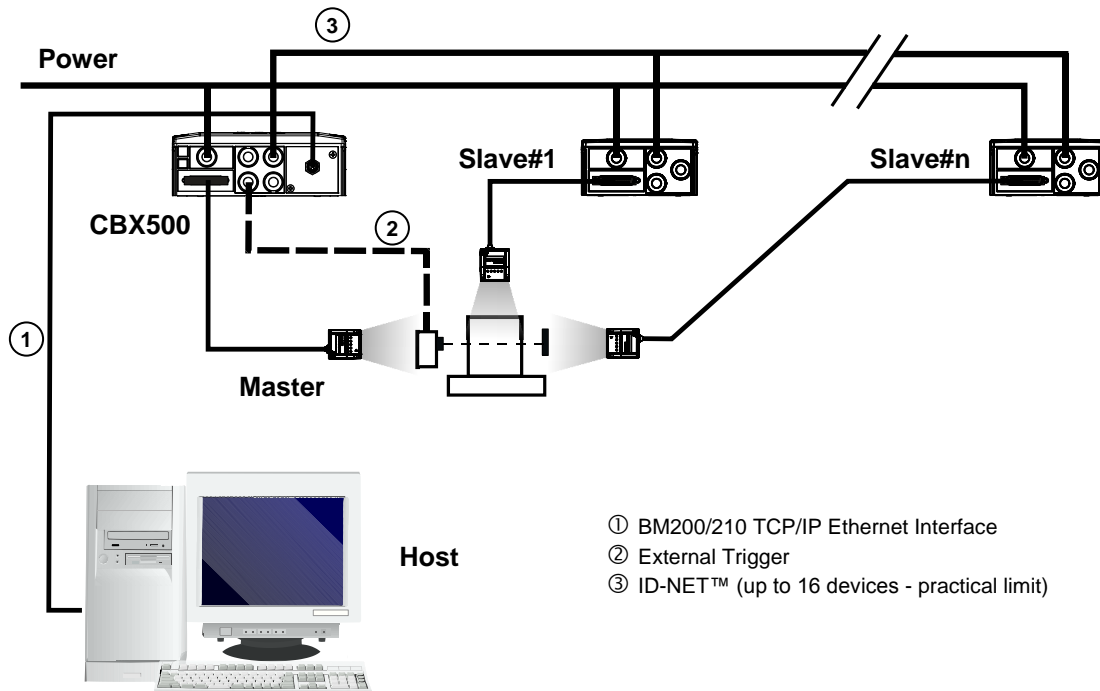

Figure 68 – ID-NET™ Synchronized Layout with BM200/210 TCP/IP Ethernet Interface to Host

5.3.3 M/S Synchronized Fieldbus Host

Alternatively, the Master scanner can communicate to the Host as a Slave node on a Fieldbus network. This requires using an accessory Fieldbus interface board installed inside the CBX500 connection box.

System configuration can be accomplished through the Auxiliary interface of the Master reader (internal CBX500 9-pin connector) using the VisiSet™ configuration program or Host Mode programming.

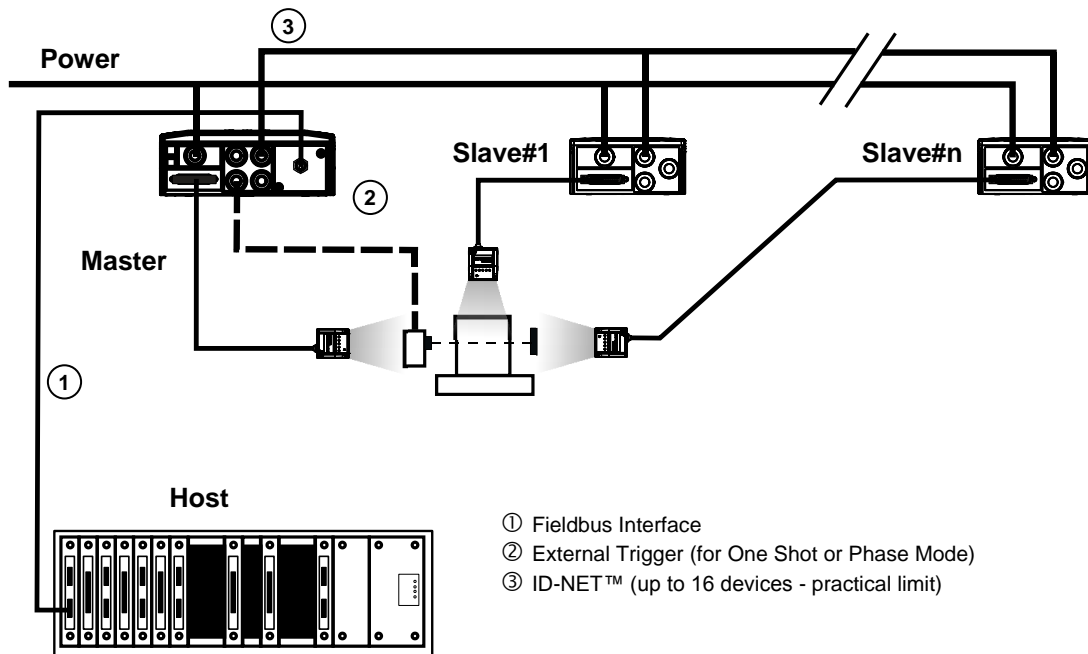

Figure 69 – ID-NET™ Synchronized Layout with Fieldbus Host

5.4 ID-NET™ MULTIDATA NETWORK (2xx-x0x and 2xx-x1x models)

5.4.1 M/S Multidata Serial Host

For a Master/Slave Multidata layout each reader has its own reading phase independent from the others; each single message is sent from the master reader to the Host computer.

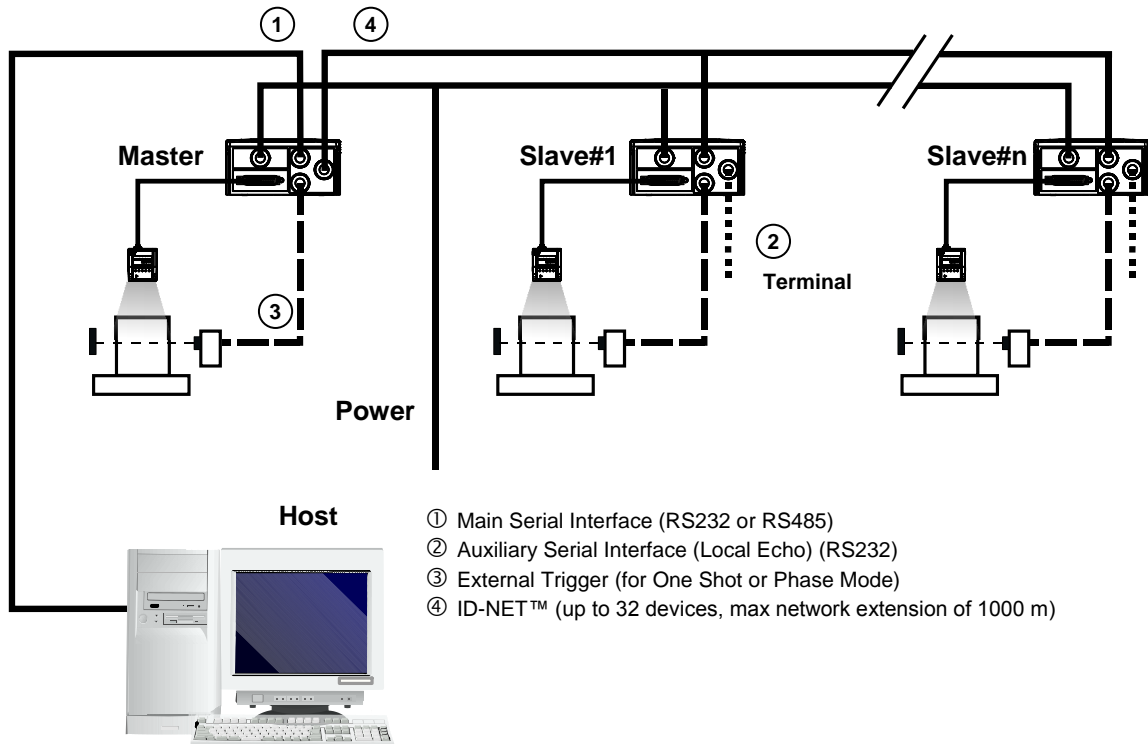

Figure 70 – ID-NET™ Multidata Layout



NOTE: The auxiliary serial interface of the slave readers can be used in Local Echo communication mode to control any single reader (visualize collected data) or to configure it using the VisiSet™ utility.

The ID-NET™ termination resistor switches must be set to ON only in the first and last CBX connection box.

5.4.2 M/S Multidata TCP/IP Host

The same configuration can be made to a Host using a TCP/IP Ethernet interface. In this case the Master is connected to a CBX500 with BM200/210 Host Interface Module installed.

The TCP/IP Ethernet, auxiliary, and ID-NET™ interfaces are connected as shown in the figure below.

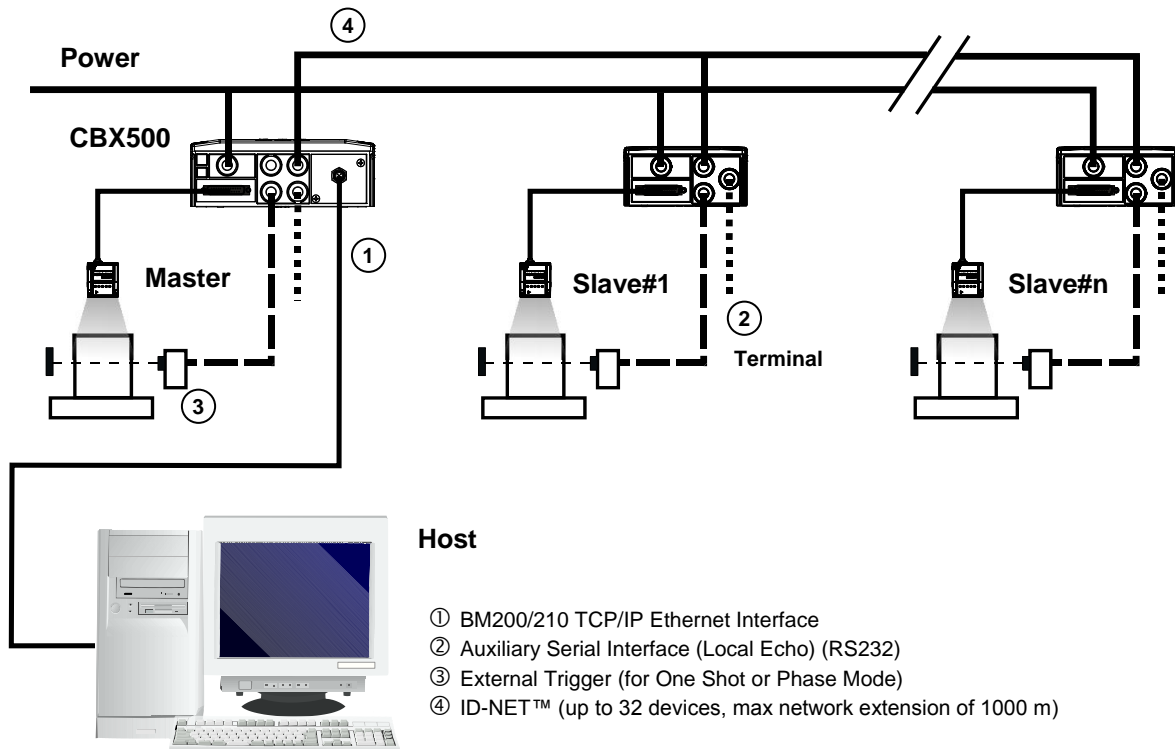

Figure 71 – ID-NET™ Multidata Layout with BM200/210 TCP/IP Ethernet Interface to Host



NOTE: The auxiliary serial interface of the slave readers can be used in Local Echo communication mode to control any single reader (visualize collected data) or to configure it using the VisiSet™ utility.

The ID-NET™ termination resistor switches must be set to ON only in the first and last CBX connection box.

5.4.3 M/S Multidata Fieldbus Host

Alternatively, the Master scanner can communicate to the Host as a Slave node on a Fieldbus network. This requires using an accessory Fieldbus interface board installed inside the CBX500 connection box.

System configuration can be accomplished through the Auxiliary interface of the Master reader (internal CBX500 9-pin connector) using the VisiSet™ configuration program or Host Mode programming.

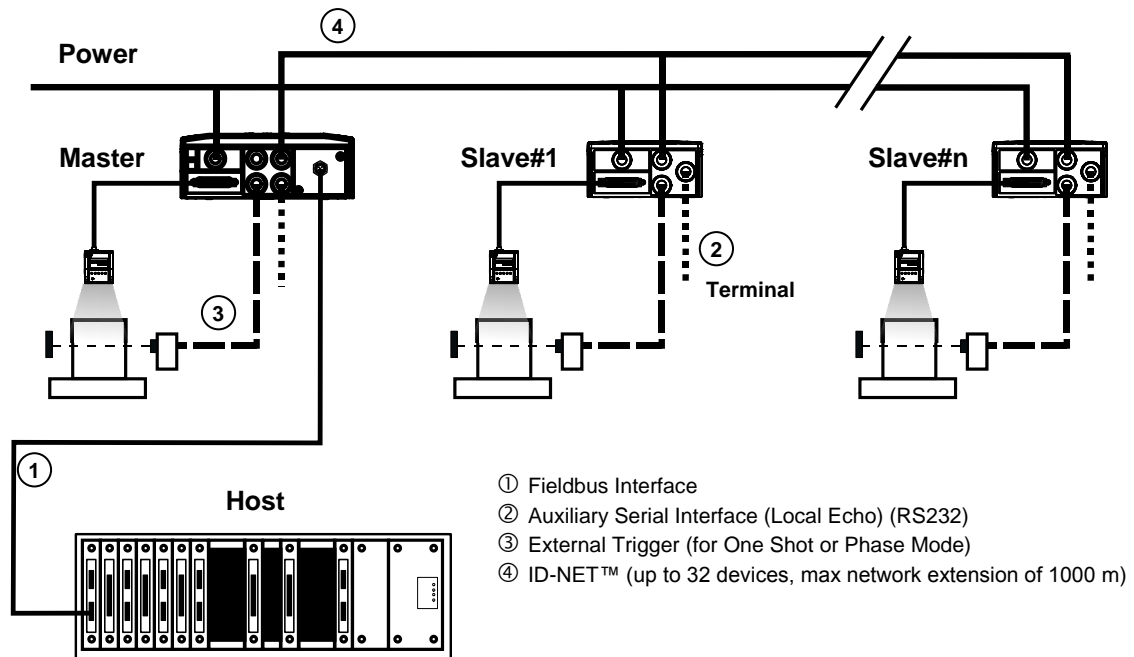

Figure 72 – ID-NET Multidata Layout™ with Fieldbus Host

5.5 PASS-THROUGH

(2xx-x0x and 2xx-x1x models)

An alternative Pass-Through layout allows the more efficient ID-NET™ network to be used. This layout is really an ID-NET Master/Slave Multidata layout which also allows **each** reader (Master and Slaves) to accept input on the Auxiliary interface, for example to connect a device such as a hand-held reader for manual code reading capability.

Each Matrix 210™ transmits its own messages plus any messages received by its Auxiliary interface onto the ID-NET™ interface. The Master passes all messages to the Host.

When One Shot or Phase Mode operating mode is used, the reader can be activated by an External Trigger (photoelectric sensor) when the object enters its reading zone.

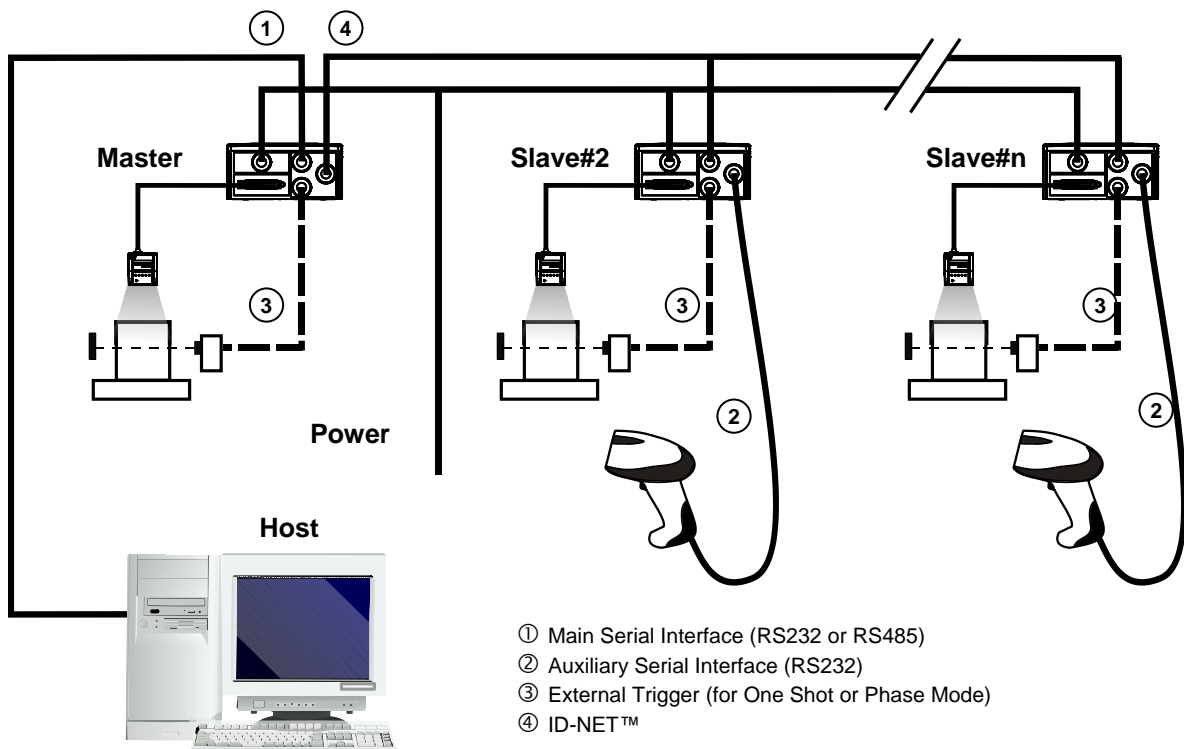

Figure 73 – Pass-Through On ID-NET™ Layout



NOTE: The reading device connected to the Host can be connected to a Fieldbus network using a Host Interface module through a CBX500 connection box.

5.6 USB CONNECTION

(2xx-x2x models only)

For Matrix 210 2xx-020 models, the USB connection is possible in two different layouts. The default baud rate is 115200. To maximize data transfer you can set it up to 921600 by configuring the reader through the Communication parameters via VisiSet™. For further details, see the Communication Folder in the VisiSet™ Help On Line.

In a Point-to-Point layout the reader is connected to a local host through its USB cable. No external power supply is necessary.

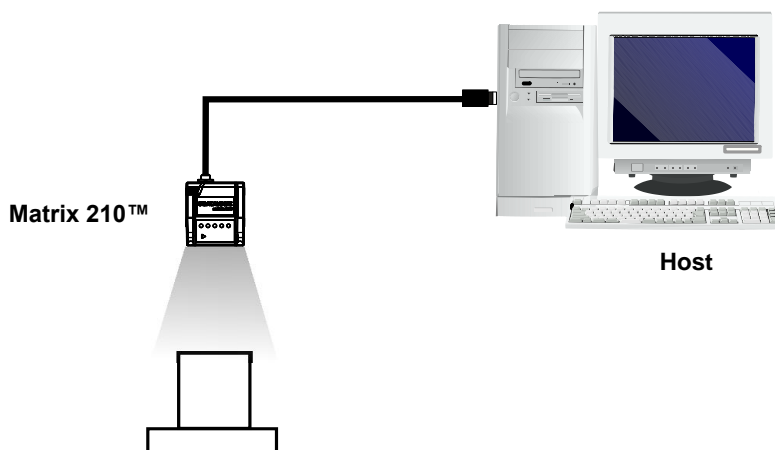

Figure 74 - USB Point-to-Point Layout

One or more Matrix 210™ USB models can be connected to USB Hub. The HUB must be able to supply 500 mA to each port.

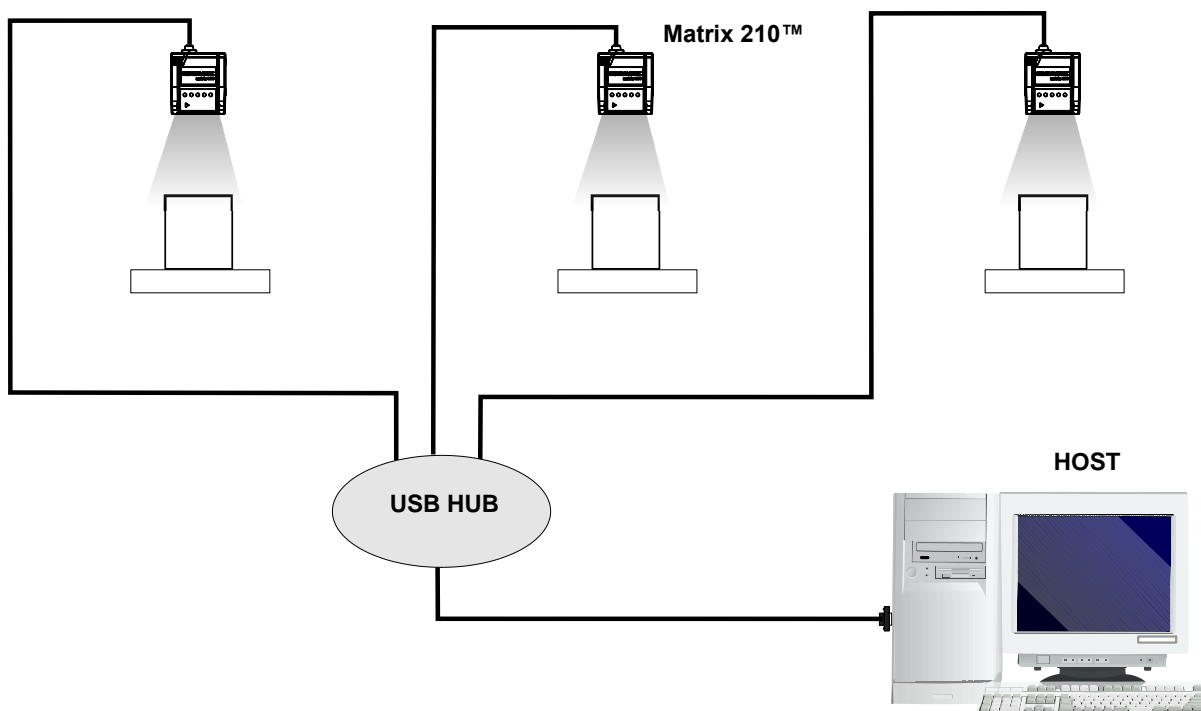

Figure 75 – Multi USB Hub Layout

5.7 OTHER LAYOUTS (2xx-x0x and 2xx-x1x models)



NOTE: Other backward-compatible layouts are available such as: RS232 Master/Slave, RS232 Pass Through and Multiplexer. We recommend using the more efficient ID-NET™ network for Master/Slave or Multiplexer layouts.

6 READING FEATURES

MODELS	Focus Distance mm (in)	Field of View ⁽¹⁾ mm (in)	PPI ⁽²⁾	Typ. Linear and Stacked Code Resolution mm (mils)	2D Code Resolution mm (mils)		Reading Distance ⁽³⁾ mm (in)	
							min.	max.
214-xxx UHD	30 (1.18)	16.5 × 10.5 (0.65 × 0.41)	1150	0.063 (2.5)	Max.	0.076 (3)	28 (1.10)	32 (1.26)
					Typ.	0.13 (5)	23 (0.91)	38 (1.50)
211-xxx NEAR	45 (1.77)	35 × 22 (1.38 × 0.87)	545	0.10 (4)	Max.	0.13 (5)	42 (1.65)	53 (2.08)
					Typ.	0.19 (7.5)	36 (1.42)	61 (2.40)
212-xxx MEDIUM	65 (2.56)	50 × 32 (1.97 × 1.26)	380	0.15 (6)	Max.	0.19 (7.5)	54 (2.13)	90 (3.54)
					Typ.	0.25 (10)	47 (1.85)	101 (3.97)
213-xxx FAR	105 (4.13)	80 × 50 (3.15 × 1.97)	238	0.20 (8)	Max.	0.25 (10)	85 (3.35)	135 (5.31)
					Typ.	0.38 (15)	70 (2.76)	192 (7.55)

⁽¹⁾ @ Focus Distance

⁽²⁾ Pixels per inch @ Focus Distance

⁽³⁾ Measurement Conditions:

- Test Chart: provided with the reader
- Still code at the center of the FOV
- Code Symbology: Data Matrix ECC 200
- Tilt Angle: 45°
- Skew Angle: 15°
- Image Processing Mode = *Advanced Code Setting*
- Module Size (mils) equal to the resolution of the code to read
- Image Processing Self Tuning = *Enabled*
- Image Processing Self Tuning Mode = *Code Contrast Levels Only* *
- Image Acquisition Self Tuning = *Enabled* (for 213-xxx models only)

* This parameter setting can increase the image processing time.

All distances are measured from the reading window to the code surface.

Depending on the code resolution, symbology and number of characters in the code, the Reading Area can be different from the FOV.

6.1 MAXIMUM LINE SPEED CALCULATION

The **Exposure Time** (or **Shutter**) parameter defines the time during which the image will be exposed to the reader sensor to be acquired. This parameter depends heavily on the environmental conditions (external lighting, image contrast etc.).

In general, a longer time corresponds to a lighter image but is susceptible to blurring due to the code movement; a shorter exposure time corresponds to a darker image.



NOTE: The following considerations must be applied only when the internal lighting system and **2D codes** are used. The Maximum line speed allowed for linear codes or postal code reading applications heavily depends on the direction of symbol movement. When the direction of movement is parallel to the elements of the code, the maximum speed is greater.

Assuming:

- **X:** Code Resolution (mm)
- **Texp:** Exposure Time (s)
- **LS:** Line Speed (mm/s)

The essential condition to avoid blurring effects between two adjacent elements in a dynamic reading application is:

$$LS \times Texp \leq X$$

The maximum (theoretical) line speed (LS) can be calculated as follows:

$$X / Texp (\min) = LS (\max)$$

Texp (min) is the minimum **Exposure Time** value obtainable for the specific application. It can be evaluated in static reading conditions and may depend on code printing quality, reader position, etc.

Using the formulas previously explained it is possible to calculate the theoretical maximum line (target) speed expected for the application, based on the maximum code resolution and the minimum suitable **Exposure Time** value.

The minimum **Exposure Time** value depends on the Matrix reader model selected for the application (reading distance) and on external lighting.

The **Internal Lighting Mode** parameter allows to set the operating mode of the internal lighting system. The possible values are:

- *Disabled*: the built-in lighting system is turned off all the time. This option can be useful only if external lighting is sufficient;
- *Always ON*: the built-in lighting system is turned on all the time at the lowest power level. This option is useful if the lighting system blinking (Strobed operating mode) disturbs the operator.
- *Very High/High/Medium-Power Strobed*: the built-in lighting system is on only during the image exposure time. Three different lighting levels can be set.



NOTE: To avoid LED array overheating, for Power Strobed settings, the program automatically limits the range of allowed values for the **Exposure Time** parameter. Therefore, after changes to Internal Lighting Mode, recheck **Exposure Time**.

CAUTION:

The maximum target speed in the application is affected by these conditions:

- **Code/Background Contrast**: maximum speed decreases when decreasing image contrast (poor quality codes, reflective transparent coverings, different supports and printing techniques).
- **Code Resolution**: maximum speed increases when decreasing code resolution (there is a decrement of overlapping effects between two adjacent elements).
- **Tilt Angle**: maximum speed decreases when increasing Tilt angle (from 0 to 45 degrees).

7 SOFTWARE CONFIGURATION

Software configuration of your Matrix 210™ for static reading or simple code reading applications can be accomplished by the Rapid Configuration procedure using the X-PRESS™ HMI (which requires no external configuration program) or by using the VisiSet™ Setup Wizard for easy setup. These procedures are described in chapter 1.

For other applications use VisiSet™ through the reader serial ports.



NOTE: For Ethernet applications, connections to VisiSet™ can be made directly through the Ethernet port of the reader (Ethernet models only), or QL500 or BM2x0 Host Interface module. See the "Configuration Through Ethernet" page in the VisiSet™ Help On-Line, or the "Matrix Family Setup Procedure Using Programming Barcodes" document on the VisiSet™ Mini-DVD (downloaded ISO file or mini-DVD accessory).

7.1 VISISET™ SYSTEM REQUIREMENTS

To install and run VisiSet™ you should have a Laptop or PC that meets or exceeds the following:

- Pentium processor
- Windows 98/2000, NT 4.0, XP, Vista, 7 or 8
- 32 MB Ram
- 5 MB free HD space
- one free RS232 serial port with 115 Kbaud (or USB-Serial Adapter)
- one Ethernet TCP/IP port
- Video Adapter (1024 x 768) or better using more than 256 colors

7.2 INSTALLING VISISET™

To install VisiSet™, proceed as follows:

1. Turn on the Laptop or PC that will be used for configuration (connected to the Matrix 210™ communication ports).
2. After Windows finishes booting, launch the VisiSet™ installation from the downloaded software package or accessory mini-DVD.
3. Follow the instructions in the installation procedure.

7.3 STARTUP

After completing the mechanical and electrical connections to Matrix 210™, you can begin software configuration as follows:

1. Power on the Matrix 210™ reader. Wait for the reader startup. The system bootstrap requires a few seconds to be completed. The reader automatically enters Run Mode.
2. Run the VisiSet™ program.
3. Press **Connect** on the VisiSet™ menu bar. The PC will automatically connect to the Matrix 210™ reader.

Upon connection, Matrix 210™ exits Run Mode and displays the Main Menu on VisiSet™ with all the commands necessary to monitor your reader's performance. You can select these commands using the mouse or by pressing the key corresponding to the letter shown on the button. See Figure 76.



Figure 76 - Main Window

7.3.1 VisiSet™ Options

The **Options** item from the VisiSet™ menu (see Figure 76) presents a window allowing you to configure:

- the logging function (**Log**)
- VisiSet™ window properties (**Environment**)
- VisiSet™ communication channel (**Communication**)

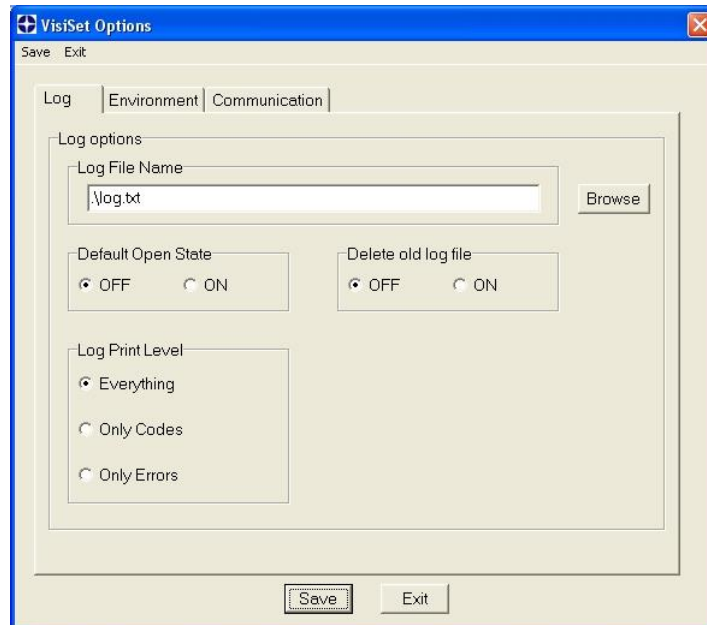

Figure 77 - Options - Log

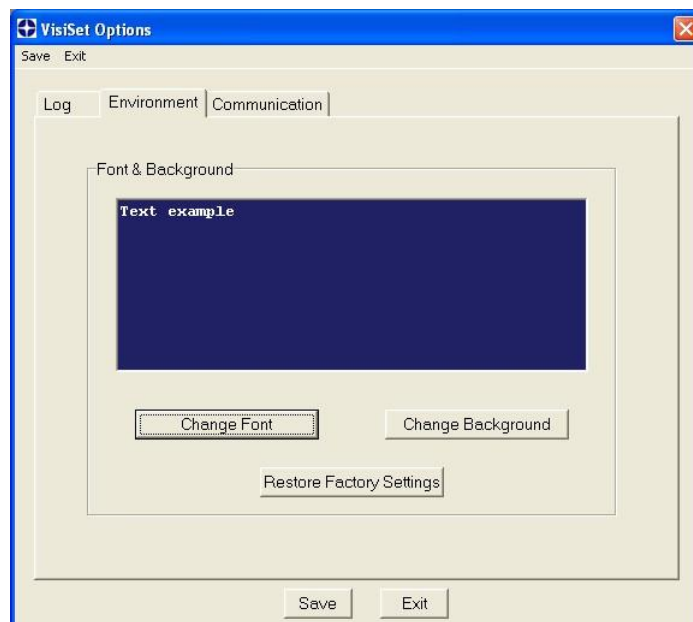

Figure 78 - Options - Environment

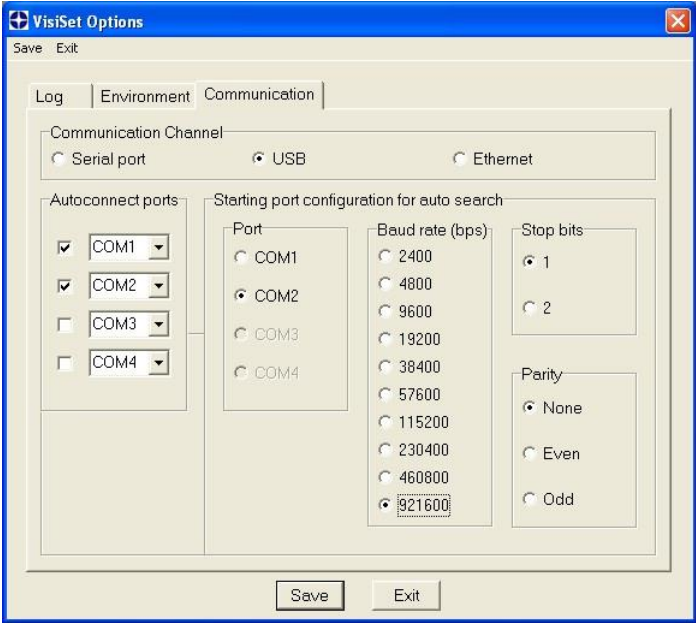

Figure 79 - Options – Communication

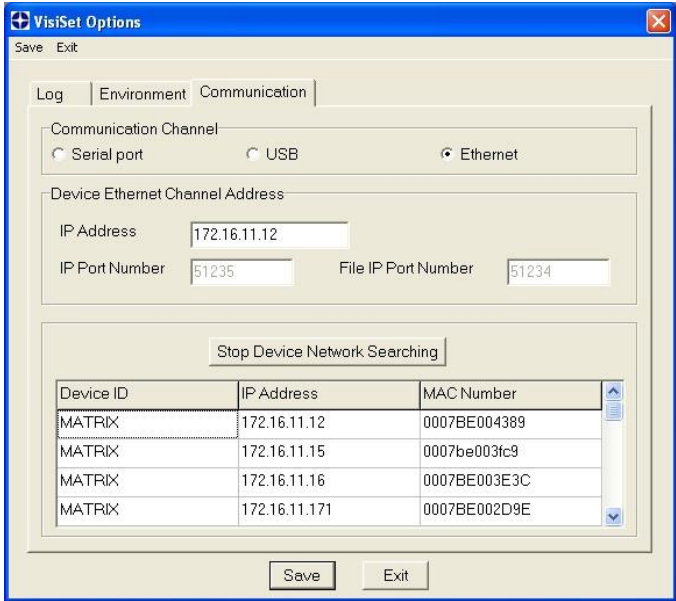

Figure 80 - Options – Communication: Ethernet

7.4 CONFIGURATION

Once connected to Matrix 210™ as described in par. 7.3, you can modify the configuration parameters as follows:

1. Press the Calibration Tool button from the Main Menu. Matrix 210™ will download its permanent memory configuration parameters with the default values (if it is the first time) to VisiSet™. The Calibration Tool window will be displayed together with the Parameter Setup window working in Interactive Mode (see par. 7.4.1 and par. 7.4.3).
2. Edit the Matrix 210™ configuration parameters according to your application requirements.
3. Use the **Calibration Tool** to fine tune the reading performance. See par. 7.4.3.
4. Close the Calibration Tool window and disable the Interactive Mode by pressing the interactive button.
5. Save the new configuration to the reader permanent memory by pressing the Send button.



NOTE: Especially for lengthy configurations in Interactive Mode, it is always good practice to periodically send the configuration to **Permanent Memory** to avoid losing the configuration in Temporary Memory.

6. Close the Parameter Setup window and press **Disconnect** on the VisiSet™ menu bar (see Figure 76) or launch **Run Mode** from the VisiSet™ Main menu.

Disconnect exits closing communication between Matrix 210™ and VisiSet™, and causes Matrix 210™ to enter Run Mode. The disconnected reader serial port is now available.

Run command does not close communication between Matrix 210™ and VisiSet™, and causes Matrix 210™ to enter Run Mode. In this case the reader output messages are displayed on the VisiSet™ terminal and the statistics are displayed in the Statistics window (Statistics enabled).

7.4.1 Edit Reader Parameters

The Parameter Setup window displays the configuration parameters grouped in a series of folders. Each parameter can be modified by selecting a different item from the prescribed list in the box, or by typing new values directly into the parameter box.

By right clicking the mouse when positioned over the name of a specific Parameter or Group, a pop-up menu appears allowing you to directly manage that particular parameter or group.

You can **View the Selected Value** for each parameter.

You can **Restore the Default Value** of each parameter or of all the parameters of a group.

Get Properties gives information about the parameter in the form of a pop-up hint that describes the default value and the range/list of valid values.

The **Short Help** gives information about the parameter in the form of a pop-up hint.

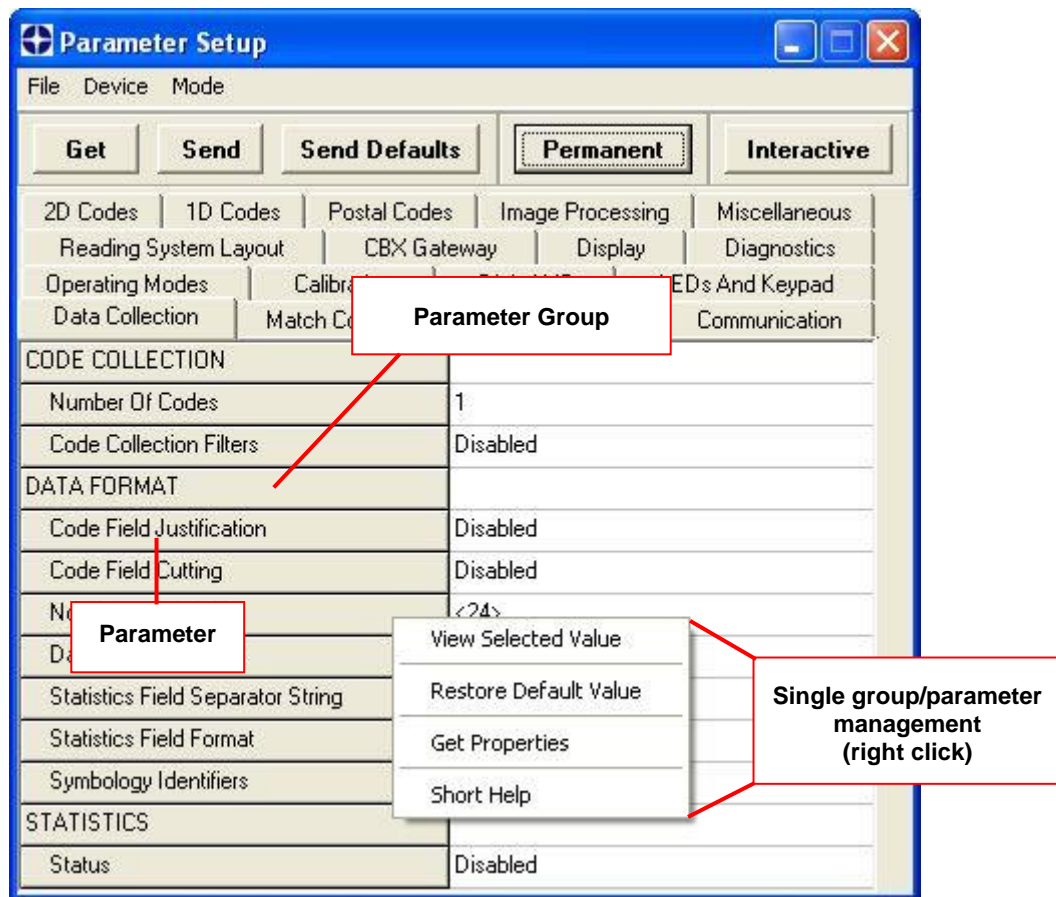

Figure 81 - Editing Parameters

Parameters to verify/modify:

<input type="checkbox"/> Operating Mode	<p>Sets the parameters which customize the reader operating mode starting from three main modes:</p> <p>One Shot: acquires a single image based on the selected value for the Acquisition Trigger and Acquisition Trigger Delay.</p> <p>Continuous: continuously acquires images with a rate up to the maximum allowable frame rate per second for the given sensor depending on the decoding time and the Region of Interest settings.</p> <p>Phase Mode: acquires images during the reading phase depending on the selected value for the Acquisition Trigger and Acquisition Trigger Delay. The Reading Phase-ON and Reading Phase-OFF events mark respectively the beginning and end of the reading phase.</p>
<input type="checkbox"/> Calibration	Calibrates the acquisition parameters to maximize the reading performance (see par. 7.4.3).
<input type="checkbox"/> Communication	<p>Configures the parameters relative to each serial port regarding the transmission, message formatting and string receiving.</p> <p>Any change to the VisiSet™ communication port parameters (baud rate, data bits, etc.) is effective as soon as the reader is disconnected from VisiSet™.</p>
<input type="checkbox"/> Reading System Layout	Allows configuring the device according to the desired layout: Standalone, ID-NET™ or Master/Slave RS232
<input type="checkbox"/> WebSentinel	Enables the Ethernet WebSentinel Agent for communication with the Datalogic WebSentinel™ plant array monitor.
<input type="checkbox"/> Ethernet	For (2xx-x1x models) Sets the parameters related to the on-board Ethernet interface and to its communication channels. Supports application protocols: TCP/IP, EtherNet/IP, Profinet IO and Modbus TCP.
<input type="checkbox"/> CBX Gateway	Sets the parameters related to the External Host Interface Module through the CBX500 and to its communication channels.
<input type="checkbox"/> Image Processing	Sets the image processing parameters shared by all available symbologies.
<input type="checkbox"/> 1D & 2D, Postal Codes	Sets the characteristics of the code symbologies to be read.
<input type="checkbox"/> Data Collection	Defines the code-collection parameters and the output message format.
<input type="checkbox"/> Digital I/O	Configures the reader input/output parameters.
<input type="checkbox"/> Match Code	Allows setting a user-defined code and relative parameters to which the read code will be compared (matched).
<input type="checkbox"/> Miscellaneous	Sets the reader name and the saved image format.
<input type="checkbox"/> Symbol Verification	Sets the parameters relative to the various specifications in the Standards which regulate code validation.
<input type="checkbox"/> LEDs And Keypad	Sets the X-PRESS™ LED and Keypad parameters related to their selected Functions: Beeper, Green Spot, Positioning, etc.
<input type="checkbox"/> Display	Sets the Display language and Layout of the BM150 Display when using the CBX500 connection box.
<input type="checkbox"/> Diagnostics	Enables various diagnostic messages, formatting and actions.

When all the configuration parameters are set correctly, save them to the Matrix 210™ reader by pressing the Send button. See Figure 81.

For successive configuration of other readers or for backup/archive copies, it is possible to save the configuration onto your PC by selecting the **Save Configuration File** option from the **File** menu.

From the **File** menu, you can also **Save Configuration As Text File** for a human readable version.

Load Configuration File (available in the **File** menu) allows you to configure a reader from a previously saved configuration file (.ini).

7.4.2 Send Configuration Options

The device parameters are divided into two main classes, Configuration and Environmental which are effected differently by the Send Configuration and Send Default Configuration commands.

Configuration Parameters regard parameters that are specific to the device. These parameters are influenced by the Send Configuration and Send Default Configuration commands, that is they are overwritten by these commands. The same parameters are modified by the following "Send Configuration with Options" and "Send Default Configuration with Options" dialogs from the Device Menu:

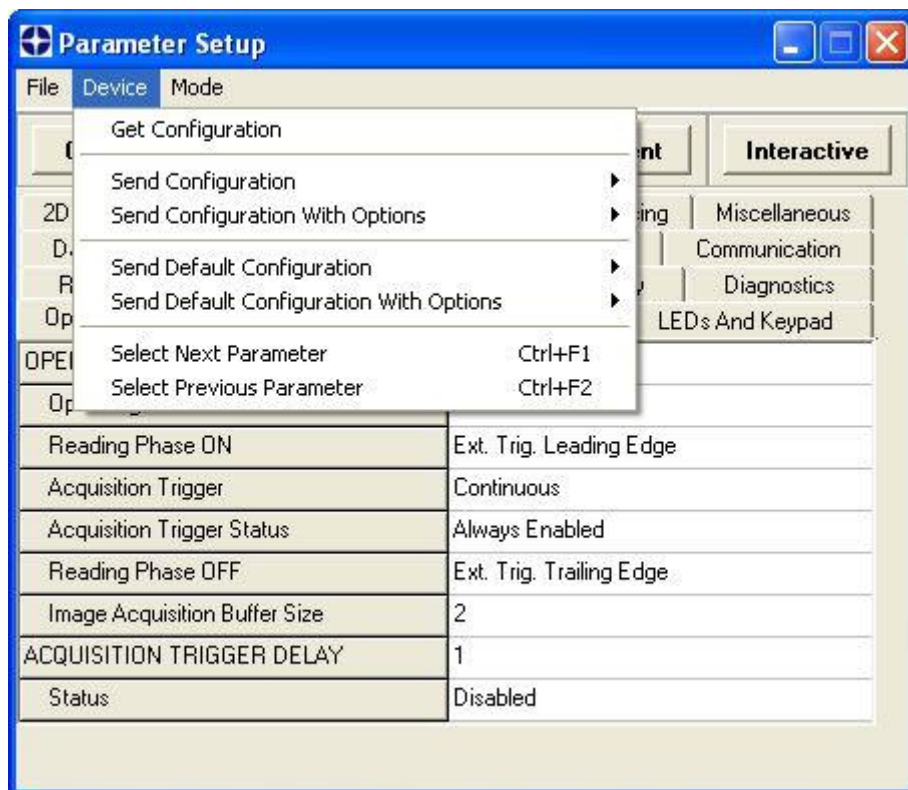

Environmental Parameters regard the device Identity and Position in a Network (ID-NET™, Master/Slave RS232, MUX 32, Ethernet) and are not influenced by the "Send Default Configuration" and "Send Configuration" commands. This allows individual devices to be configured differently without affecting their recognized position in the network.

The following is a list of the Environmental Parameters:

READING SYSTEM LAYOUT

- Device Network Setting
- Number of Slaves

DEVICE NETWORK SETTINGS

- Topology Role
- ID-NET Slave Address
- Network Baud Rate
- Acquisition Trigger String (available only in Multidata configuration)
- Reading Phase ON String (available only in Multidata configuration)
- Reading Phase OFF String (available only in Multidata configuration)
- Header String (available only in Slave Multidata configuration)
- Terminator String (available only in Slave Multidata configuration)
- Link Failure String (available only in Master Synchronized configuration)
- Link Failure Timeout (ms) (available only in Master Synchronized configuration)

EXPECTED SLAVE DEVICES

- Status
- Device Description
- Device Network Name

MAIN PORT

- Communication Protocol
- Multidrop Address

ETHERNET SYSTEM (on-board)

- Status
- DHCP Client
- IP Address
- Subnet Mask
- Gateway Address
- DNS1 Address

HOST INTERFACE

- Host Interface Type

CBX ETHERNET SYSTEM (CBX with Host Interface Modules)

- Status
- DHCP Client
- IP Address
- Subnet Mask
- Gateway Address

PROFIBUS

- Node Address

DEVICENET

- Node Address

ETHERNET-IP

- IP Addressing Mode
- IP Address
- Subnet Mask
- Gateway Address

PROFINET IO

- IP Addressing Mode
- IP Address
- Subnet Mask
- Gateway Address

CANOPEN

- Node Address

CC-LINK

- Node Address

MODBUS TCP

- IP Addressing Mode
- IP Address
- Subnet Mask
- Gateway Address

MISCELLANEOUS

- Reader Name
- User Name
- Line Name

For device replacement it is necessary to send the previously saved configuration (both Configuration and Environmental parameters) to the new device. To do this select "Send Configuration with Options" from the Device Menu and check the Environmental Parameters checkbox:

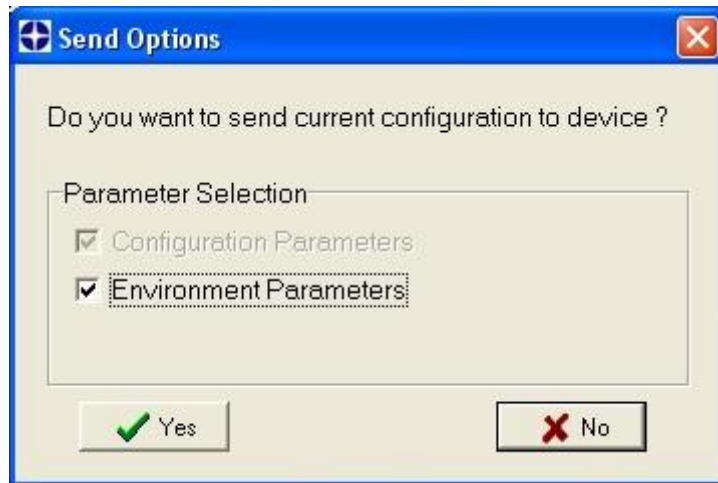

In order to return a device to its absolute default parameters including Environmental parameters, the following "Send Default Configuration with Options" dialog must be used:

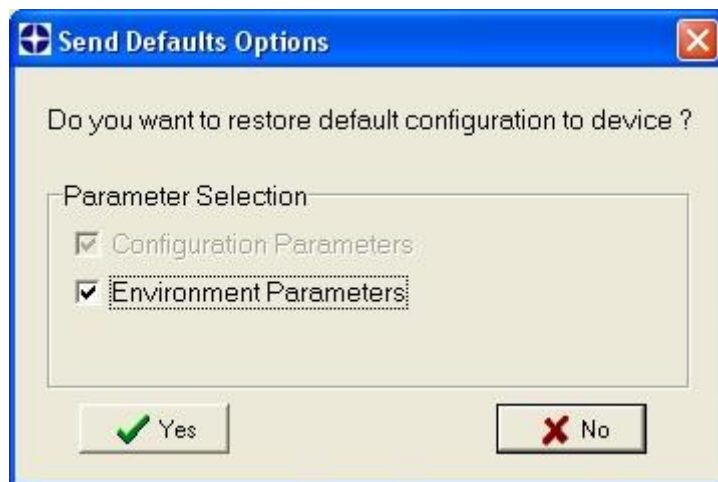

7.4.3 Calibration

VisiSet™ provides a Calibration Tool to maximize the reading performance by tuning the acquisition parameters and the time of the delayed triggers.

By selecting the Calibration Tool from the VisiSet™ Main Menu (F), the following window appears together with the Parameter Setup window:

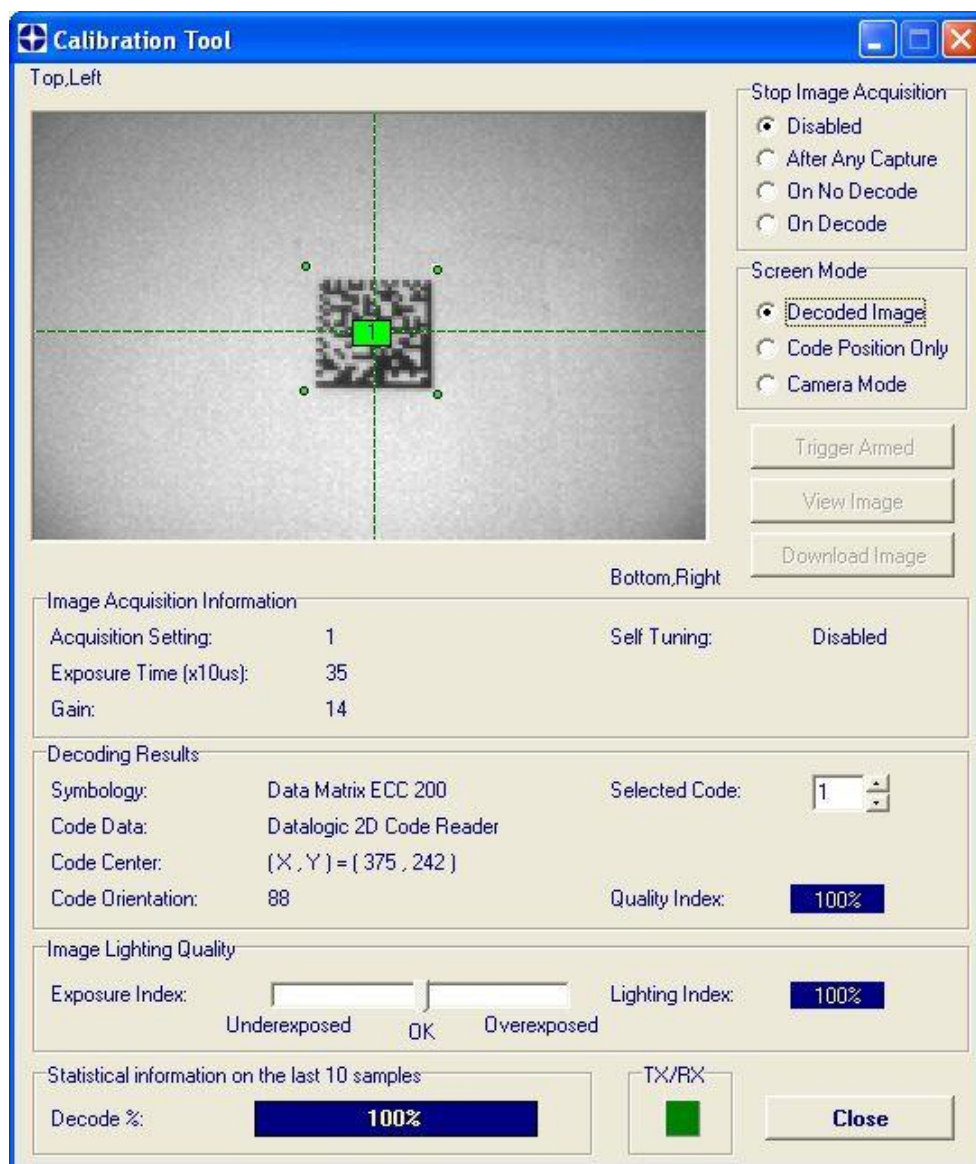

Figure 82 - Calibration OK

This tool provides a "real-time" image display while Matrix 210™ is reading. It also gives immediate results on the performance of the installed Matrix 210™ reader.

If Self Tuning is enabled, the Calibration Tool window indicates the region where the calibration algorithm is performed: it is within the central box delimited by four red dots.



NOTE: If using Region Of Interest windowing, some or all of the four red dots delimiting the calibration algorithm area may be located outside the VisiSet™ display area (not visible).

The Parameter Setup window works in Interactive Mode in order to cause each parameter setting to be immediately effective.



NOTE: If you want to save the temporary configuration to permanent memory, you must first close the Calibration Tool window. Then, you must disable the Interactive Mode and select the **Permanent Memory** option from the **Send Configuration** item in the Device menu.

The following examples show some of the typical conditions occurring during the installation:

Under-exposure:

To correct this result it is recommended to change the following parameters in their order of appearance:

1. increase the **Exposure Time**
2. increase the **Gain**



NOTE: In general, a longer exposure time corresponds to a lighter image but is susceptible to blurring due to code movement. Exposure time is also limited by the Internal Lighting mode parameter. **Longer exposure times can be set if the power strobe level is lowered.**

High gain settings may produce a grainy image that may affect the decoding process.

The screenshot displays two windows from a software interface. The left window, titled 'Calibration Tool', shows a dark image of a QR code with a green crosshair. Below the image, there are controls for 'Image Acquisition Information' (Acquisition Setting: 1, Exposure Time (x100us): 100, Gain: 10), 'Decoding Results' (Symbology: Data Matrix ECC 200, Code Data: Datalogic 2D Code Reader, Code Center: (X, Y) = (396 , 238), Code Orientation: 89, Quality Index: 100%), and 'Image Lighting Quality' (Exposure Index: Underexposed, Lighting Index: 76%). The right window, titled 'Parameter Setup', shows the 'Interactive' mode selected. It contains a table of settings:

IMAGE ACQUISITION SETTING	
Status	Enabled
Self Tuning	Disabled
Internal Lighting Mode	High-Power Strobed
Exposure Time (x100us)	10
Gain	10
Gain Increasing	x1
Image Polarity Inversion	Disabled
Region Of Interest: Top	0
Region Of Interest: Bottom	479
Region Of Interest: Left	0
Region Of Interest: Right	751
Image Filter	Disabled

Figure 83 - Example Under Exposure: Too Dark

Over-exposure:

To correct this result it is recommended to change the following parameters in their order of appearance:

1. decrease the **Gain**
2. decrease the **Exposure Time**

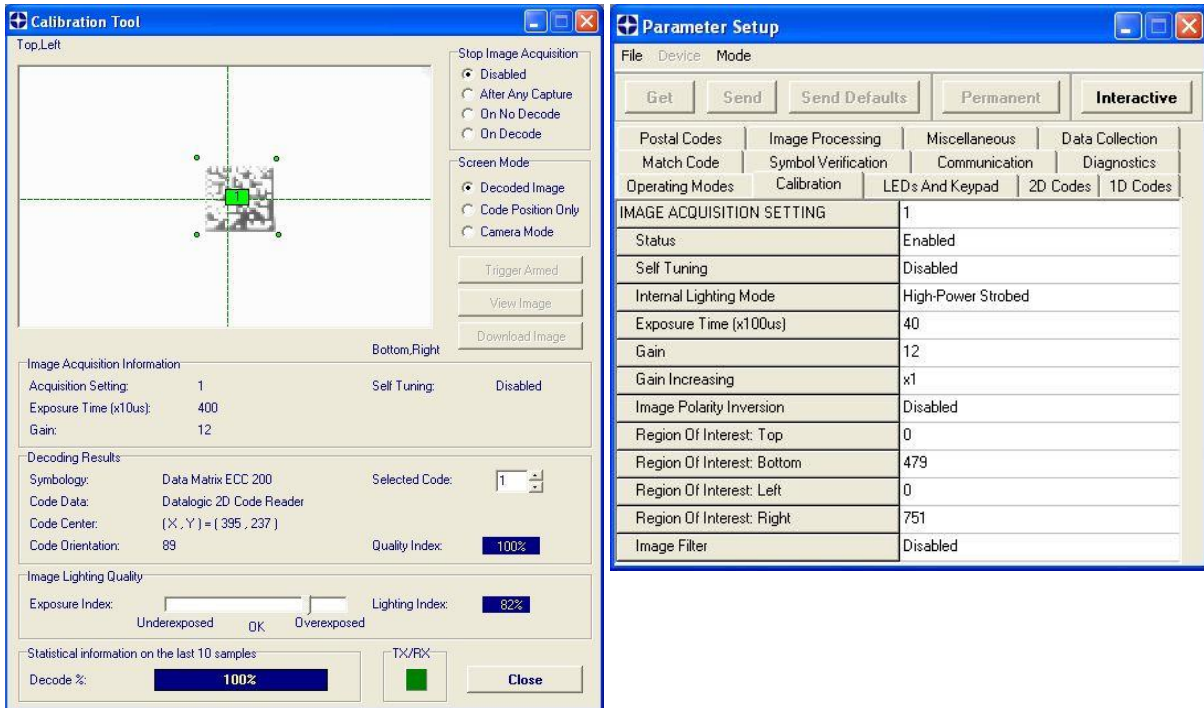

Figure 84 - Example Over Exposure: Too Light

Moving code out of the Field of View:

To correct this result and have the code completely visible in F.O.V., it is possible to follow one or both the procedures listed below:

- reposition the reader
- use the **Acquisition Trigger Delay** by tuning the **Delay Time (x100µs)**

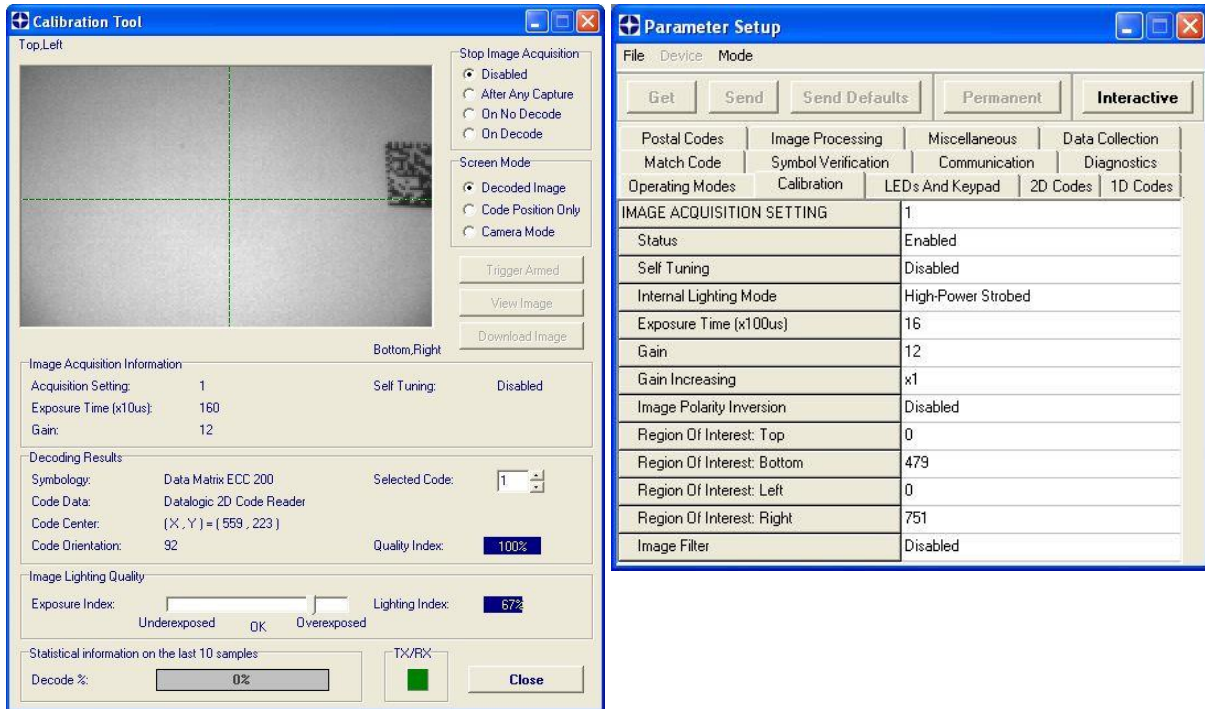

Figure 85 - Example out of FOV

7.4.4 Multi Image Acquisition Settings

When controlled variable conditions occur in the application, Multiple **Image Acquisition Settings** (up to 10), can be defined to create a database of parameter groups that handle each specific application condition. This database of pre-defined settings functions cyclically and therefore automatically improves system flexibility and readiness.

For example, an application may have two stable but different lighting conditions which require different lighting options. One Image Acquisition Setting could enable and use the internal illuminator and a second setting could disable Internal Lighting to use external lighting. These two groups will be used cyclically on each acquisition in order to automatically capture the correctly lighted image.

Image Acquisition Settings are found in the VisiSet™ **Calibration** parameter setup menu. By selecting a different number and enabling its **Status** you can define the parameters for a new group.

7.4.5 Run Time Self Tuning (RTST)

Run Time Self-Tuning (RTST) increases Matrix's flexibility in the presence of uncontrolled variable conditions (lighting, code contrast, etc.) by automatically adjusting its acquisition parameters.

Self Tuning Calibration

In the **Calibration** parameter setup menu, the **Self Tuning** parameters manage the Image Acquisition Setting parameters dynamically. Self Tuning provides automatic adjustment in run time of different acquisition parameters (*Exposure Time* and/or *Gain*) for each captured image based on calculations performed on previous acquisitions. These dynamic settings will be used instead of the static settings saved in memory.

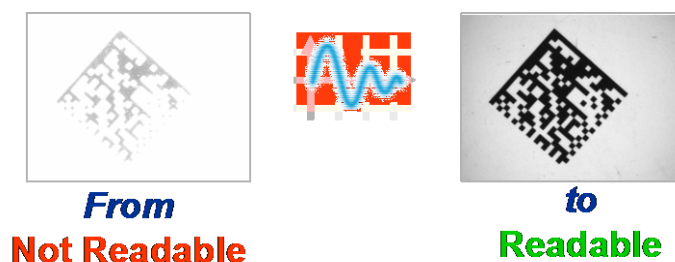

For more details see the Matrix 210™ Help On-Line.

Self Tuning Image Processing

In the **Image Processing** parameter setup menu, the **Self Tuning** parameters manage the Image Processing and Symbology related parameters. They perform different processing attempts on the same captured image according to the selected Self Tuning Mode parameter value: (*Symbologies Only*, *Processing Modes Only*, *Decoding Methods Only*, *Code Contrast Levels Only*, *Image Mirroring Only*, or *General Purpose*).

For more details see the Matrix 210™ Help On-Line.

7.4.6 Region Of Interest Windowing

In order to satisfy very high throughput applications, higher frame rates can be achieved using the powerful **Region Of Interest Windowing** parameters in the Calibration parameter setup menu.

Region Of Interest Windowing allows defining a region or window within the reader FOV. The Top, Bottom, Left and Right parameters allow to precisely define the image window to be processed, visualized and saved.

In Matrix 210™ the frame rate is dependent on the number of rows and columns in the defined window.

The smaller the window, the lower the frame period and consequently the higher the frame rate. In general the Image Processing time can be reduced by reducing the window dimensions.

The image shows two software windows. The left window is titled 'Calibration Tool' and displays a barcode with a red rectangular region of interest (ROI) overlaid. Four red arrows point to the corners of this ROI. Below the image, there are various settings and a 'Decode %' indicator showing 100%. The right window is titled 'Parameter Setup' and shows a table of settings. The 'Region Of Interest' parameters are highlighted with a red box:

Operating Modes	Calibration	LEDs And Keypad	2D Codes	1D Codes
IMAGE ACQUISITION SETTING				
Status	Enabled			
Self Tuning	Disabled			
Internal Lighting Mode	High-Power Strobed			
Exposure Time (x100us)	14			
Gain	20			
Gain Increasing	x1			
Image Polarity Inversion	Disabled			
Region Of Interest: Top	100			
Region Of Interest: Bottom	400			
Region Of Interest: Left	150			
Region Of Interest: Right	600			
Image Filter	Disabled			



NOTE: If using Region Of Interest windowing, some or all of the four red dots delimiting the calibration algorithm area may be located outside the VisiSet™ display area (not visible).

7.4.7 Direct Part Marking Applications

Decoding Method: Direct Marking

For **Data Matrix** and **QR** code the **Decoding Method** parameter selects the decoding algorithm according to the printing/marking technique used to create the symbol and on the overall printing/marking quality. The **Direct Marking** selection improves the decode rate for low quality Direct Part Mark codes and in general for Direct Part Mark codes with dot peening type module shapes.

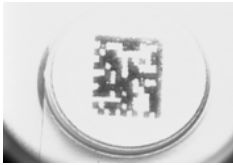

Washed out and Axial Distortion



Dot Peening On Scratched Surface

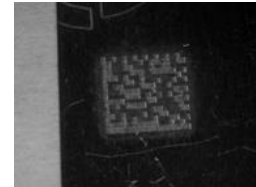

Low Contrast Problem

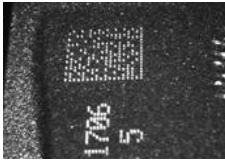

Background Problems



Marked On Curved Shiny Surface

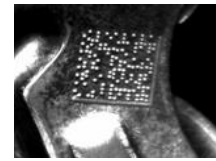

Axial distortion



Half moon effects

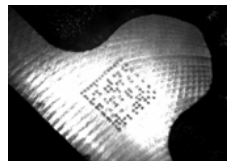

Shiny surface, noisy background



Low contrast, noisy background

All the previous examples are successfully read selecting the **Direct Marking Decoding Method**.

Image Filter

Sets the filter to be applied to the image before being processed. This parameter can be used to successfully decode particular ink-spread printed codes (i.e. direct part mark codes).

A different filter can be applied to each *Image Acquisition Setting*.

The **Erode** Filter enlarges the image dark zones to increase readability.

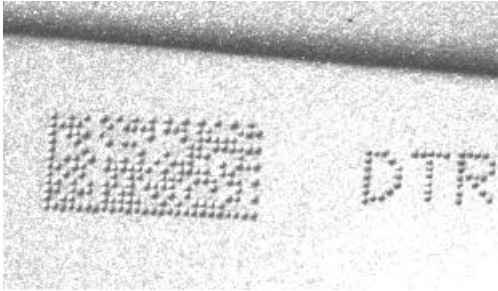

Before - No Read



After - Readable

Erode

The **Dilate** Filter enlarges the image white zones to increase readability.

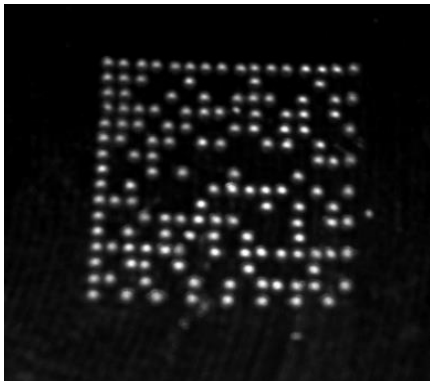

Before - No Read

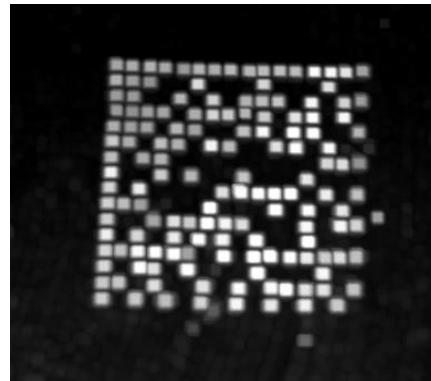

After - Readable

Dilate

The **Close** filter eliminates dark areas (defects) in the white zones of the image.



Before - No Read

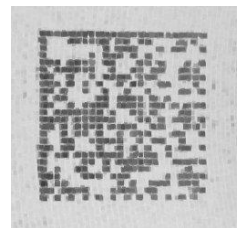

After - Readable

Close

The **Open** filter eliminates white areas (defects) in the dark zones of the image.

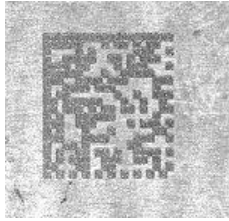

Before - No Read

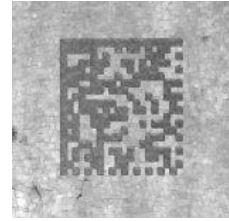

After - Readable

Open

The **Contrast Stretching** filter maximizes image contrast.

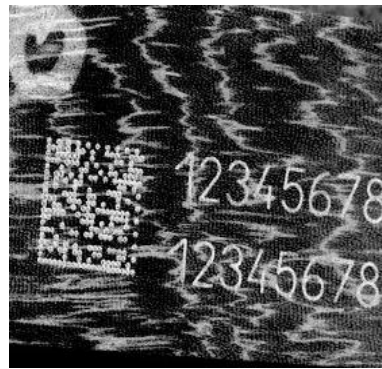
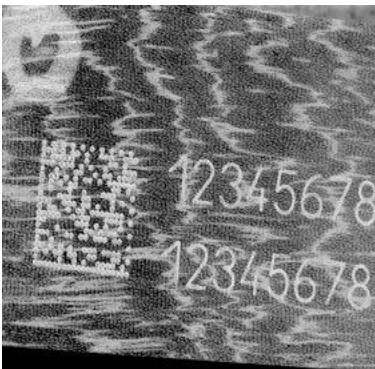

Before - No Read

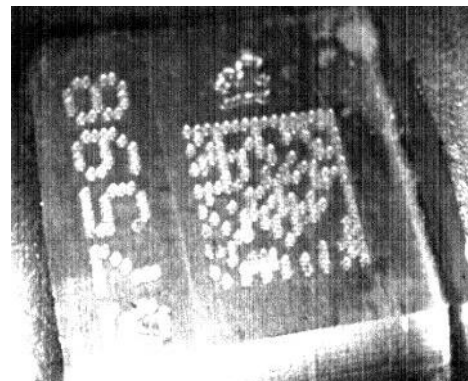

After - Readable

Contrast Stretching

The ***Histogram Equalization*** filter makes the gray level distribution uniform.



Before - No Read



After - Readable

Histogram Equalization

The ***Smoothing*** filter deletes small (insignificant) details in the center of the image.



Before - No Read



After - Readable

Smoothing

The ***Sharpening*** filter improves out of focus images.

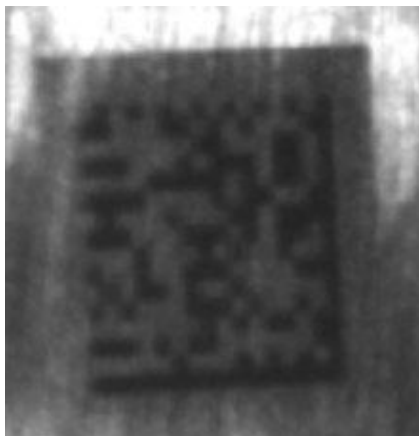

Before - No Read

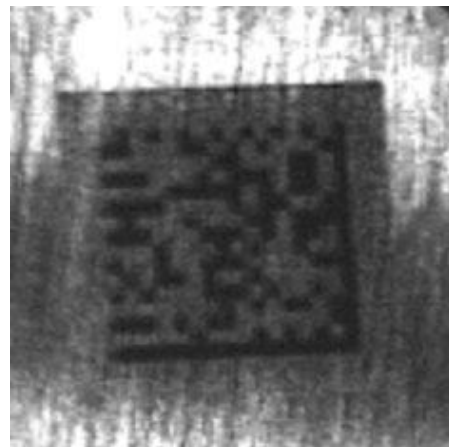

After - Readable

Sharpening

The **Deblurring** filter improves blurred images.

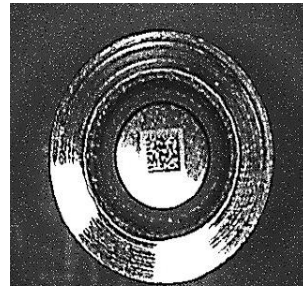
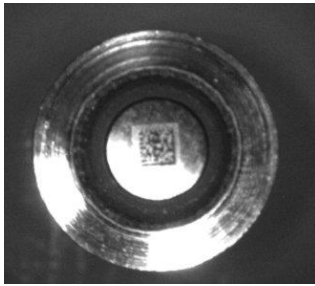

Before - No Read

After - Readable

Deblurring

The **Black Enhancement** filter produces a nonlinear increase in the black level for light images.

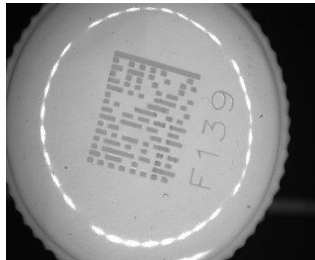

Before - No Read

After - Readable

Black Enhancement

The **White Enhancement** filter produces a nonlinear increase in the white level for dark images.

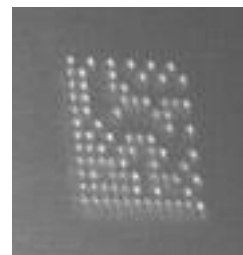

Before - No Read

After - Readable

White Enhancement

7.5 IMAGE CAPTURE AND DECODING

By using the **Capture Image** and **Decode Last Image** functions from the VisiSet™ Main menu, you can get information about the image decodable codes in terms of Symbology, encoded Data, Position and Orientation, Decode Time and Code Quality Assessment Metrics.

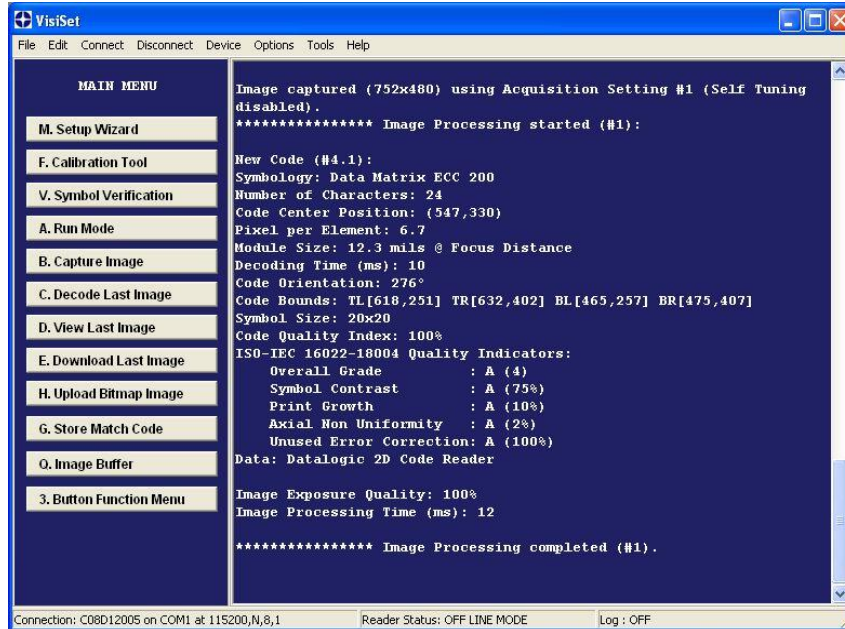

Figure 86 - Capture and Decoding Functions

7.6 STATISTICS

Statistics on the reading performance can be viewed by enabling the Statistics parameter and selecting the **View Statistics** item in the **File** menu. One of three different windows appears depending on the operating mode.

Refer to the VisiSet™ Help On Line for more details.

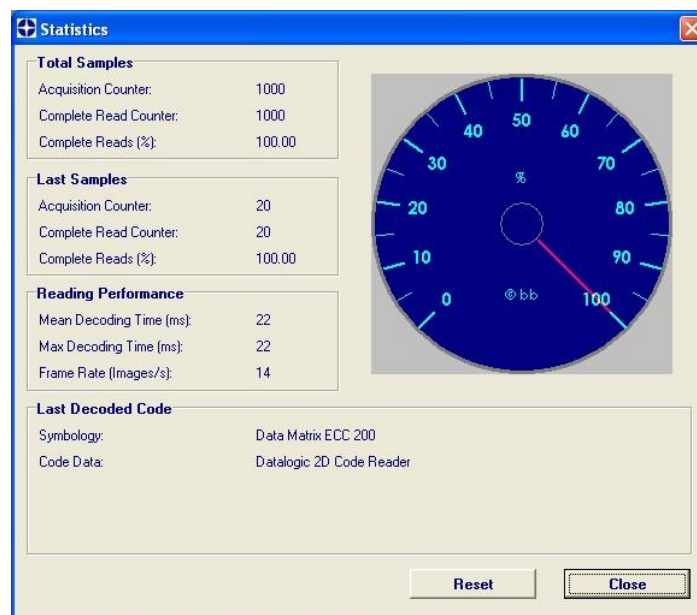

Figure 87 - Code Statistics

8 MAINTENANCE

8.1 CLEANING

Clean the reading window (see Figure A, 1) periodically for continued correct operation of the reader.

Dust, dirt, etc. on the window may alter the reading performance.

Repeat the operation frequently in particularly dirty environments.

Use soft material and alcohol to clean the window and avoid any abrasive substances.

9 TROUBLESHOOTING

9.1 GENERAL GUIDELINES

- When wiring the device, pay careful attention to the signal name (acronym) on the CBX100/500 spring clamp connectors (chp. 4). If you are connecting directly to the Matrix 210™ 25-pin male D-sub connector pay attention to the pin number of the signals (chp. **Error! Reference source not found.**).
- If you need information about a certain reader parameter you can refer to the VisiSet™ program help files. Either connect the device and select the parameter you're interested in by pressing the F1 key, or select **Help>Parameters Help** from the command menu.
- If you're unable to fix the problem and you're going to contact your local Datalogic office or Datalogic Partner or ARC, we suggest providing (if possible): Application Program version, Parameter Configuration file, Serial Number and Order Number of your reader. You can get this information while VisiSet™ is connected to the reader: the Application Program version is shown in the Terminal Window; the Parameter Configuration can be saved to an .ini file applying the **File>Save Configuration File** command in the Parameter Setup window; Serial Number and Order Number can be obtained by applying the respective command in the **Tools** menu.

TROUBLESHOOTING GUIDE	
Problem	Suggestion
Power ON: the "POWER" LED is not lit.	<ul style="list-style-type: none"> • Is power connected? • If using a power adapter (like PG6000), is it connected to wall outlet? • If using rail power, does rail have power? • If using CBX, does it have power (check switch and LED)? • Check if you are referring to the 25-pin connector or to the CBX spring clamp connectors. • Measure Voltage either at pin 13 and pin 25 (for 25-pin connector) or at spring clamp Vdc and GND (for CBX).
One Shot or Phase Mode using the Input 1 (External Trigger) or Input 2: the "TRIGGER" LED is not blinking while the External Trigger is switching.	<ul style="list-style-type: none"> • Check if you are referring to the 25-pin connector or to the CBX spring clamp connectors. • Is the sensor connected to the Input 1 or Input 2? • Is power supplied to the photo sensor? • For NPN configuration, is power supplied to one of the two I1 or I2 signals (A or B)? • For PNP configuration, is one of the two I1 or I2 signals grounded (A or B)? • Are the photo sensor LEDS (if any) working correctly? • Is the sensor/reflector system aligned (if present)? • In the Digital I/O folder check the EXTERNAL TRIGGER or INPUT 2\Debounce Filter parameter setting. • In the Operating Mode folder check the settings for Reading Phase-ON, Acquisition Trigger and Reading Phase-OFF parameters.

TROUBLESHOOTING GUIDE	
Problem	Suggestion
One Shot or Phase Mode using serial trigger source: the "TRIGGER" LED is not blinking.	<ul style="list-style-type: none"> • In the Operating Mode folder check the settings for Reading Phase-ON, Acquisition Trigger and Reading Phase-OFF parameters. • Are the COM port parameters (Baud Rate, Parity, Data Bits, Stop Bits, Handshake) correctly assigned? • In the communication folder, check the settings of Reading Phase-ON String, Acquisition Trigger String and Reading Phase-OFF String parameters. • Is the serial trigger source correctly connected?
Phase Mode: the "TRIGGER" LED is correctly blinking but no image is displayed in VisiSet™ Calibration Tool window.	<ul style="list-style-type: none"> • Is the Phase frequency lower than the maximum frame rate?
Continuous Mode: the "TRIGGER" LED is not blinking.	<ul style="list-style-type: none"> • Verify the correct software configuration settings.
Any Operating Mode: the "TRIGGER" LED is correctly blinking but no result is transmitted by the reader at the end of the reading phase collection.	<ul style="list-style-type: none"> • In the Data Collection folder check the settings for the CODE COLLECTION, DATA FORMAT and STATISTICS parameter groups.
Image not clear:	<ul style="list-style-type: none"> • Verify the Focus procedure
Image focused but not decoded:	<ul style="list-style-type: none"> • Verify the Calibrate Image Density procedure.
Reading: the reader always transmits the No Read Message	<ul style="list-style-type: none"> • Run the Rapid Configuration procedure in chapter 1. • Position the reader as described in par. 3.3 and through the VisiSet™ Calibration Tool: <ul style="list-style-type: none"> – Tune the ACQUISITION TRIGGER DELAY, if the moving code is out of the reader field of view; – Set the Continuous Operating Mode if no external trigger source is available; – Tune the IMAGE ACQUISITION SETTING to improve the code image quality; – Check the parameter setting in Decoding, 2D Codes, 1D Codes, and Postal Codes folders; – View the full resolution code image to check the printing or marking quality.
Communication: reader is not transmitting anything to the host.	<ul style="list-style-type: none"> • Is the serial cable wiring correct? • If using CBX, be sure the RS485 termination switch is OFF. • Are the host serial port settings the same as the reader serial port settings? • In VisiSet™ Digital I/O folder, "COM" LED can be configured to indicate MAIN COM port TX or MAIN COM port RX.

TROUBLESHOOTING GUIDE	
Problem	Suggestion
<p>Communication: data transferred to the host are incorrect, corrupted or incomplete.</p>	<ul style="list-style-type: none"> • Are the host serial port settings the same as the reader serial port settings? • In VisiSet™ Communication folder check the settings of Header and Terminator String parameters. • In VisiSet™ Data Collection folder, check the settings of DATA FORMAT parameter group.
<p>How do I obtain my reader Serial Number?</p>	<ul style="list-style-type: none"> • The reader Serial Number consists of 9 characters: one letter, 2 numbers, another letter followed by 5 numbers. • The reader Serial Number is printed on a label that is affixed on the bottom case near the reading window. • The Serial Number can also be obtained by selecting Tools/Get Reader Serial Number from the command menu in VisiSet™. A dedicated window will appear.
<p>How do I obtain my reader Order Number?</p>	<ul style="list-style-type: none"> • The reader Order Number consists of 9 numbers. • The reader Order Number can be obtained by selecting the Tools/Get Reader Order Number from the command menu in VisiSet™. A dedicated window will appear.

10 TECHNICAL FEATURES

ELECTRICAL FEATURES	Matrix 210 2xx-x0x	Matrix 210 2xx-x1x	Matrix 210 2xx-x2x
Power Supply Voltage Consumption	10 to 30 Vdc 0.35 to 0.13 A, 3.9 W max. 0.16 A @ 24 V.	10 to 30 Vdc 0.4 to 0.15 A, 4.5 W max 0.18 A @ 24 V	5 Vdc 0.5 A, 2.5 W max
Communication Interfaces Main - RS232 - RS485 full-duplex - RS485 half-duplex Auxiliary - RS232 ID-NET™ Ethernet ²	2400 to 115200 bit/s 2400 to 115200 bit/s 2400 to 115200 bit/s 2400 to 115200 bit/s Up to 1MBaud	2400 to 115200 bit/s 2400 to 115200 bit/s 2400 to 115200 bit/s 2400 to 115200 bit/s Up to 1MBaud 10/100 Mbit/s	USB 2.0 up to 921600 bit/s
Inputs Input 1 (External Trigger) and Input 2	Opto-coupled and polarity insensitive	Opto-coupled and polarity insensitive	
Max. Voltage	30 Vdc	30 Vdc	
Max. Input Current	10 mA	10 mA	
Outputs Output 1 and Output 2	Opto-coupled	Opto-coupled	
V_{Out} ($I_{Load} = 0$ mA) Max.	30 Vdc	30 Vdc	
V_{Out} ($I_{Load} = 10$ mA) Max.	1.8 Vdc	1.8 Vdc	
$P_D = V_{Out} \times I_{Load}$ Max.	170 mW	170 mW	
OPTICAL FEATURES			
Image Sensor	CMOS sensor with Global Shutter		
Image Format	WVGA (752x480)		
Frame Rate	up to 60 frames/sec. @ full window size		
Pitch	± 35°		
Tilt	0° - 360°		
Lighting System	Internal LED Illuminator to EN 62471		
ENVIRONMENTAL FEATURES			
Operating Temperature ³	0 to 50 °C (32 to 122 °F)		
Storage Temperature	-20 to 70 °C (-4 to 158 °F)		
Max. Humidity	90% non condensing		
Vibration Resistance EN 60068-2-6	14 mm @ 2 to 10 Hz; 1.5 mm @ 13 to 55 Hz; 2 g @ 70 to 200 Hz; 2 hours on each axis		
Bump Resistance EN 60068-2-29	30g; 6 ms; 5000 shocks on each axis		
Shock Resistance EN 60068-2-27	30g; 11 ms; 3 shocks on each axis		
Protection Class EN 60529	IP65		

² for Ethernet models only; supports application protocols: TCP/IP, EtherNet/IP, Profinet-IO, Modbus TCP

³ high ambient temperature applications should use metal mounting bracket for heat dissipation

PHYSICAL FEATURES	Matrix 210 2xx-1xx	Matrix 210 2xx-0xx
Dimensions	50 x 25 x 45 mm (1.97 x 0.98 x 1.77 in)	54 x 32 x 45 mm (2.13 x 1.26 x 1.77 in)
Weight	204 g. (7.2 oz.) with cable	190 g. (6.7 oz.) with cable
Material	ZAMA	Aluminium alloy
SOFTWARE FEATURES		
Readable Code Symbologies		
1-D and stacked	2-D	POSTAL
<ul style="list-style-type: none"> • PDF417 Standard and Micro PDF417 • Code 128 (GS1-128) • Code 39 (Standard and Full ASCII) • Code 32 • MSI • Standard 2 of 5 • Matrix 2 of 5 • Interleaved 2 of 5 • Codabar • Code 93 • Pharmacode • EAN-8/13 - UPC-A/E (including Addon 2 and Addon 5) • GS1 DataBar Family • Composite Symbologies 	<ul style="list-style-type: none"> • Data Matrix ECC 200 (Standard, GS1 and Direct Marking) • QR Code (Standard and Direct Marking) • Micro QR Code • MAXICODE • Aztec Code 	<ul style="list-style-type: none"> • Australia Post • Royal Mail 4 State Customer • Kix Code • Japan Post • PLANET • POSTNET • POSTNET (+BB) • Intelligent Mail • Swedish Post
Operating Mode	ONE SHOT, CONTINUOUS, PHASE MODE	
Configuration Methods	X-PRESS™ Human Machine Interface Windows-based SW (VisiSet™) via serial, Ethernet or USB link Serial Host Mode Programming sequences	
Parameter Storage	Permanent memory (Flash)	
CODE QUALITY METRICS		
Standard	Supported Symbologies	
ISO/IEC 16022	Data Matrix ECC 200	
ISO/IEC 18004	QR Code	
ISO/IEC 15415	Data Matrix ECC 200, QR Code	
ISO/IEC 15416	Code 128, Code 39, Interleaved 2 of 5, Codabar, Code 93, EAN-8/13, UPC-A/E	
AS9132A	Data Matrix ECC 200	
AIM DPM	Data Matrix ECC 200, QR Code	
USER INTERFACE		
LED Indicators	Power, Ready, Good, Trigger, Com, Status, (Ethernet Network), (Green Spot)	
Other	Keypad Button (configurable via VisiSet™); Beeper	

A ALTERNATIVE CONNECTIONS

POWER COM AND I/O CONNECTOR

The Matrix 210™ reader is equipped with a 25-pin male D-sub connector for connection to the power supply, serial interfaces and input/output signals. The details of the connector pins are indicated in the following table:

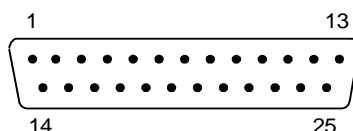

Figure 88 - 25-pin Male D-sub Connector

Power, COM and I/O Connector Pinout				
Pin	Name	Function		
13, 9	Vdc	Power supply input voltage +		
25, 7	GND	Power supply input voltage -		
1	CHASSIS	Cable shield connected to chassis		
18	I1A	External Trigger A (polarity insensitive)		
19	I1B	External Trigger B (polarity insensitive)		
6	I2A	Input 2 A (polarity insensitive)		
10	I2B	Input 2 B (polarity insensitive)		
8	O1+	Output 1 +		
22	O1-	Output 1 -		
11	O2+	Output 2 +		
12	O2-	Output 2 -		
20	RX	Auxiliary RS232 RX		
21	TX	Auxiliary RS232 TX		
23	ID+	ID-NET™ network +		
24	ID-	ID-NET™ network -		
14, 15, 16, 17	NC	Not Connected		
Pin	Name	RS232	RS485 Full-Duplex	RS485 Half-Duplex
2	MAIN INTERFACE (SW SELECTABLE)	TX	TX+	RTX+
3		RX	*RX+	RTX-
4		RTS	TX-	
5		CTS	*RX-	

* Do not leave floating, see par. 4.2.2 for connection details.

In order to meet EMC requirements:

- connect the reader chassis to the plant earth ground by means of a flat copper braid shorter than 100 mm;
- for direct connections, connect the main interface cable shield to pin 1 of the 25-pin connector.

ON-BOARD ETHERNET CONNECTOR

In Matrix 210 2xx-x1x models, an M12 D-Coded connector is provided for the on-board Ethernet connection. This interface is IEEE 802.3 10 BaseT and IEEE 802.3u 100 BaseTx compliant.



Figure 89 - M12 D-Coded Female Ethernet Network Connector

On-Board Ethernet Network Connector Pinout		
Pin	Name	Function
1	TX +	Transmitted data (+)
2	RX +	Received data (+)
3	TX -	Transmitted data (-)
4	RX -	Received data (-)

ID-NET™ NETWORK TERMINATION

The network must be properly terminated by a 120 Ohm resistor at the first and last reader of the network.

INPUTS

There are two opto-coupled polarity insensitive inputs available on the 25-pin connector of the reader: Input 1 (External Trigger) and Input 2, a generic input. See par. 4.5 for more details.

The electrical features of both inputs are:

$$V_{AB} = 30 \text{ Vdc max.}$$

$$I_{IN} = 10 \text{ mA max.}$$

The relative pins on the 25-pin connector are:

Pin	Name	Function
9	Vdc	Power Supply input voltage +
18	I1A	External Trigger A (polarity insensitive)
19	I1B	External Trigger B (polarity insensitive)
6	I2A	Input 2 A (polarity insensitive)
10	I2B	Input 2 B (polarity insensitive)
7	GND	Power Supply input voltage -

OUTPUTS

Two opto-coupled general purpose outputs are available on the 25-pin connector. See par. 4.6 for more details.

The pinout is the following:

Pin	Name	Function
9	Vdc	Power Supply input voltage +
8	O1+	Configurable digital output 1 - positive pin
22	O1-	Configurable digital output 1 - negative pin
11	O2+	Configurable digital output 2 - positive pin
12	O2-	Configurable digital output 2 - negative pin
7	GND	Power Supply input voltage -

The electrical features of the two outputs are the following:

$$V_{\text{Out}} (I_{\text{Load}} = 0 \text{ mA}) \text{ max} = 30 \text{ Vdc.}$$

$$V_{\text{Out}} (I_{\text{Load}} = 10 \text{ mA}) \text{ max} = 1.8 \text{ Vdc}$$

$$I_{\text{Load}} \text{ max} = 40 \text{ mA continuous; } 130 \text{ mA pulsed}$$

$$P_{\text{D}} = V_{\text{Out}} \times I_{\text{Load}} \text{ max} = 170 \text{ mW}$$

The output signals are fully programmable being determined by the configured Activation/Deactivation events, Deactivation Timeout or a combination of the two. Refer to the Digital I/O folder in the VisiSet™ Help On Line for further details.

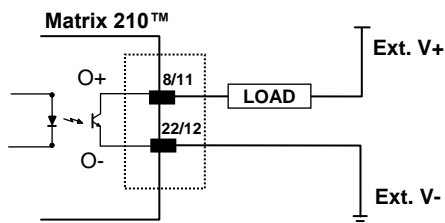

Figure 90 – Isolated Current Sinking Output Connection

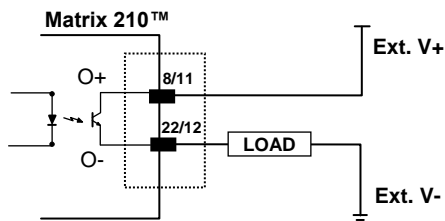

Figure 91 – Isolated Current Sourcing Output Connection

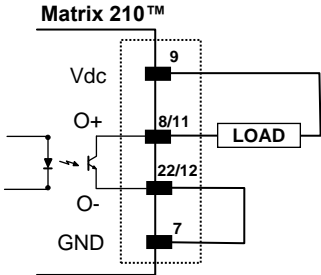

Figure 92 – Non-Isolated Current Sinking Output Connection

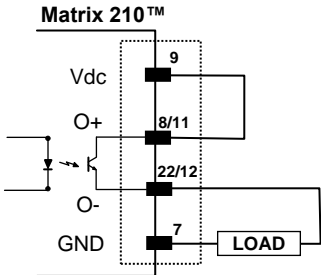

Figure 93 – Non-Isolated Current Sourcing Output Connection

USER INTERFACE – SERIAL HOST

RS232 PC-side connections			
<p>9-pin male connector</p>		<p>25-pin male connector</p>	
Pin	Name	Pin	Name
2	RX	3	RX
3	TX	2	TX
5	GND	7	GND
7	RTS	4	RTS
8	CTS	5	CTS

How To Build A Simple Interface Test Cable:

The following wiring diagram shows a simple test cable including power, external (push-button) trigger and PC RS232 COM port connections.

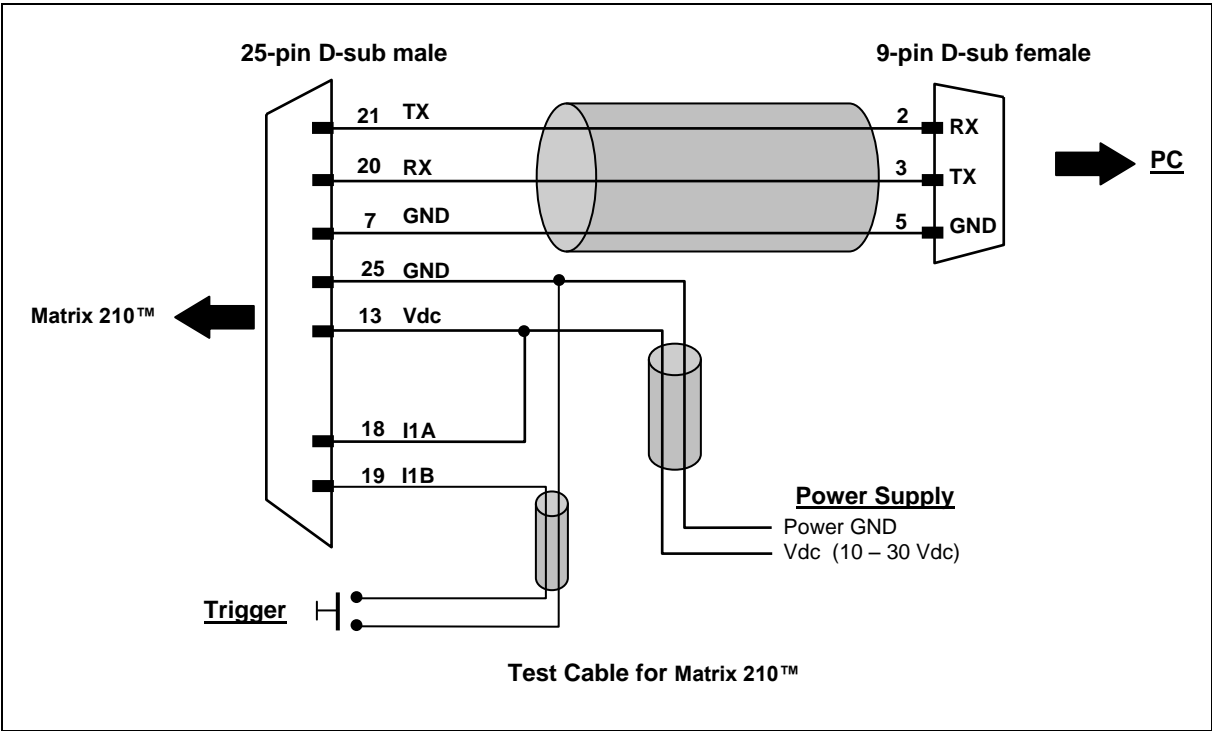

Figure 94- Test Cable for Matrix 210™

GLOSSARY

AIM

(Association for Automatic Identification and Mobility): AIM Global is the international trade association representing automatic identification and mobility technology solution providers.

AIM DPM Quality Guideline

Standard applicable to the symbol quality assessment of direct part marking (DPM) performed in using two-dimensional bar code symbols. It defines modifications to the measurement and grading of several symbol quality parameters.

AS9132

Standard defining uniform quality and technical requirements for direct part marking (DPM) using Data Matrix symbologies.

Barcodes (1D Codes)

A pattern of variable-width bars and spaces which represents numeric or alphanumeric data in machine-readable form. The general format of a barcode symbol consists of a leading margin, start character, data or message character, check character (if any), stop character, and trailing margin. Within this framework, each recognizable symbology uses its own unique format.

BIOS

Basic Input Output System. A collection of ROM-based code with a standard API used to interface with standard PC hardware.

Bit

Binary digit. One bit is the basic unit of binary information. Generally, eight consecutive bits compose one byte of data. The pattern of 0 and 1 values within the byte determines its meaning.

Bits per Second (bps)

Number of bits transmitted or received per second.

Byte

On an addressable boundary, eight adjacent binary digits (0 and 1) combined in a pattern to represent a specific character or numeric value. Bits are numbered from the right, 0 through 7, with bit 0 the low-order bit. One byte in memory can be used to store one ASCII character.

Composite Symbologies

Consist of a linear component, which encodes the item's primary data, and an adjacent 2D composite component, which encodes supplementary data to the linear component.

Dark Field Illumination

Lighting of surfaces at low angles used to avoid direct reflection of the light in the reader's lens.

Decode

To recognize a barcode symbology (e.g., Codabar, Code 128, Code 3 of 9, UPC/EAN, etc.) and analyze the content of the barcode scanned.

Depth of Field

The difference between the minimum and the maximum distance of the object in the field of view that appears to be in focus.

Diffused Illumination

Distributed soft lighting from a wide variety of angles used to eliminate shadows and direct reflection effects from highly reflective surfaces.

Direct Part Mark (DPM)

A symbol marked on an object using specific techniques like dot peening, laser etching, chemical etching, etc.

EEPROM

Electrically Erasable Programmable Read-Only Memory. An on-board non-volatile memory chip.

Element

The basic unit of data encoding in a 1D or 2D symbol. A single bar, space, cell, dot.

Exposure Time

For digital cameras based on image sensors equipped with an electronic shutter, it defines the time during which the image will be exposed to the sensor to be acquired.

Flash

Non-volatile memory for storing application and configuration files.

Host

A computer that serves other terminals in a network, providing services such as network control, database access, special programs, supervisory programs, or programming languages.

Image Processing

Any form of information processing for which the input is an image and the output is for instance a set of features of the image.

Image Resolution

The number of rows and columns of pixels in an image. The total number of pixels of an image sensor.

Image Sensor

Device converting a visual image to an electric signal. It is usually an array of CCD (Charge Coupled Devices) or CMOS (Complementary Metal Oxide Semiconductor) pixel sensors.

IEC

(International Electrotechnical Commission): Global organization that publishes international standards for electrical, electronic, and other technologies.

IP Address

The terminal's network address. Networks use IP addresses to determine where to send data that is being transmitted over a network. An IP address is a 32-bit number referred to as a series of 8-bit numbers in decimal dot notation (e.g., 130.24.34.03). The highest 8-bit number you can use is 254.

ISO

(International Organization for Standardization): A network of the national standards institutes of several countries producing world-wide industrial and commercial standards.

LED (Light Emitting Diode)

A low power electronic light source commonly used as an indicator light. It uses less power than an incandescent light bulb but more than a Liquid Crystal Display (LCD).

LED Illuminator

LED technology used as an extended lighting source in which extra optics added to the chip allow it to emit a complex radiated light pattern.

Matrix Symbologies (2D Codes)

An arrangement of regular polygon shaped cells where the center-to-center distance of adjacent elements is uniform. Matrix symbols may include recognition patterns which do not follow the same rules as the other elements within the symbol.

Multidrop

A communication protocol for connecting two or more readers in a network with a concentrator (or controller) and characterized by the use of individual device addresses.

Multi-row (or Stacked) Symbologies

Symbologies where a long symbol is broken into sections and stacked one upon another similar to sentences in a paragraph.

RAM

Random Access Memory. Data in RAM can be accessed in random order, and quickly written and read.

Symbol Verification

The act of processing a code to determine whether or not it meets specific requirements.

Transmission Control Protocol/Internet Protocol (TCP/IP)

A suite of standard network protocols that were originally used in UNIX environments but are now used in many others. The TCP governs sequenced data; the IP governs packet forwarding. TCP/IP is the primary protocol that defines the Internet.

INDEX

A

Accessories, 33
Alternative Connections, 108
Application Examples, 34
Auxiliary RS232 Interface, 53

C

Calibration, 90
CBX Electrical Connections, 42
Compliance, vii

D

Diagnostic Indication, 31

E

Edit Reader Parameters, 84
Ethernet Interface, 60
Ethernet Networks, 65
External Lighting Systems, 36

G

General View, x
Glossary, 113

H

Handling, viii

I

ID-NET™ Cables, 48
ID-NET™ Interface, 48
ID-NET™ Multidata Network, 70
ID-NET™ Network Termination, 53, 109
ID-NET™ Response Time, 49
ID-NET™ Synchronized Network, 66
Image Capture and Decoding, 101
Inputs, 54, 109
Installing VisiSet™, 79

L

Layouts, 61

M

Main Serial Interface, 43
Maintenance, 102
Mechanical Dimensions, 38
Model Description, 32
Mounting and Positioning Matrix 210™, 40

O

On-Board Ethernet Connector, 109
Other Layouts, 75
Outputs, 57, 110

P

Package Contents, 37
Patents, vi
Point-to-Point, 61
Power Com and I/O Connector, 108
Power Supply, vii, 43

R

Rapid Configuration, 1
Reader Configuration, 83
Reading Features, 76
References, vi
RS232 Interface, 44
RS485 Full-Duplex, 45
RS485 Half-Duplex, 46

S

Software Configuration, 79
Statistics, 101
Support Through The Website, vi

T

Technical Features, 106
Troubleshooting, 103

U

USB Connection, 74

V

VisiSet™ Options, 81

**Datalogic Automation S.r.l.**

Via Lavino 265
40050 Monte San Pietro
Bologna - Italy

declares that the

MATRIX 210 ; Compact 2D Imager

and all its models

are in conformity with the requirements of the European Council Directives listed below:

2004 / 108 / EC EMC Directive

This Declaration is based upon compliance of the products to the following standards:

EN 55022 (CLASS A ITE), DECEMBER 2010:

*INFORMATION TECHNOLOGY EQUIPMENT
RADIO DISTURBANCE CHARACTERISTICS
LIMITS AND METHODS OF MEASUREMENTS*

EN 61000-6-2, SEPTEMBER 2005:

*ELECTROMAGNETIC COMPATIBILITY (EMC)
PART 6-2: GENERIC STANDARDS - IMMUNITY FOR INDUSTRIAL
ENVIRONMENTS*

Monte San Pietro, January 20th, 2012

Paolo Morselli
Quality Manager





 **DATALOGIC**

www.datalogic.com