

Keysight 16048D Test Leads

NOTICE: This document contains references to Agilent Technologies. Agilent's former Test and Measurement business has become Keysight Technologies. For more information, go to www.keysight.com.



Notices

The information contained in this document is subject to change without notice.

This document contains proprietary information that is protected by copyright. All rights are reserved. No part of this document may be photocopied, reproduced, or translated to another language without the prior written consent of the Keysight Technologies.

© Copyright 1990 - 2014 Keysight Technologies

Manual Printing History

The manual's printing date and part number indicate its current edition. The printing date changes when a new edition is printed. (Minor corrections and updates that are incorporated at reprint do not cause the date to change.) The manual part number changes when extensive technical changes are incorporated.

1990	First Edition
November 1998	Second Edition
August 1999	Third Edition (part number : 16048-90031)
May 2000	Fourth Edition (part number : 16048-90031)
July 2010	Fifth Edition (part number : 16048-90031)
November 2014	Sixth Edition (part number : 16048-90031)

Safety Summary

The following general safety precautions must be observed during all phases of operation, service, and repair of this instrument. Failure to comply with these precautions or with specific WARNINGS elsewhere in this manual may impair the protection provided by the equipment. In addition it violates safety standards of design, manufacture, and intended use of the instrument.

The Keysight Technologies assumes no liability for the customer's failure to comply with these requirements.

NOTE

16048D comply with INSTALLATION CATEGORY I and POLLUTION DEGREE 2 in IEC61010-1. 16048D are INDOOR USE product.

- Ground The Instrument

To avoid electric shock hazard, the instrument chassis and cabinet must be connected to a safety earth ground by the supplied power cable with earth blade.

- DO NOT Operate In An Explosive Atmosphere

Do not operate the instrument in the presence of flammable gasses or fumes. Operation of any electrical instrument in such an environment constitutes a definite safety hazard.

- Keep Away From Live Circuits

Operating personnel must not remove instrument covers. Component replacement and internal adjustments must be made by qualified maintenance personnel. Do not replace components with the power cable connected. Under certain conditions, dangerous voltages may exist even with the power cable removed. To avoid injuries, always disconnect power and discharge circuits before touching them.

- DO NOT Service Or Adjust Alone

Do not attempt internal service or adjustment unless another person, capable of rendering first aid and resuscitation, is present.

- DO NOT Substitute Parts Or Modify Instrument

Because of the danger of introducing additional hazards, do not install substitute parts or perform unauthorized modifications to the instrument. Return the instrument to a Keysight Technologies Sales and Service Office for service and repair to ensure that safety features are maintained.

- Dangerous Procedure Warnings

Warnings, such as the example below, precede potentially dangerous procedures throughout this manual. Instructions contained in the warnings must be followed.

WARNING

Dangerous voltages, capable of causing death, are presenting this instrument. Use extreme caution when handling, testing, and adjusting this instrument.

Certification

Keysight Technologies certifies that this product met its published specifications at the time of shipment from the factory. Keysight Technologies further certifies that its calibration measurements are traceable to the United States National Institute of Standards and Technology, to the extent allowed by the Institution's calibration facility, or to the calibration facilities of other International Standards Organization members.

Warranty

This Keysight Technologies instrument product is warranted against defects in material and workmanship for a period corresponding to the individual warranty periods of its component products. Instruments are warranted for a period of one year. Fixtures and adapters are warranted for a period of 90 days. During the warranty period, Keysight Technologies will, at its option, either repair or replace products that prove to be defective.

For warranty service or repair, this product must be returned to a service facility designated by Keysight Technologies. Buyer shall prepay shipping charges to Keysight Technologies and Keysight Technologies shall pay shipping charges to return the product to Buyer. However, Buyer shall pay all shipping charges, duties, and taxes for products returned to Keysight Technologies from another country.

Keysight Technologies warrants that its software and firmware designated by Keysight Technologies for use with an instrument will execute its programming instruction when properly installed on that instrument. Keysight Technologies does not warrant that the operation of the instrument, or software, or firmware will be uninterrupted or error free.

Limitation Of Warranty

The foregoing warranty shall not apply to defects resulting from improper or inadequate maintenance by Buyer, Buyer-supplied software or interfacing, unauthorized modification or misuse, operation outside the environmental specifications for the product, or improper site preparation or maintenance.

IMPORTANT

No other warranty is expressed or implied. Keysight Technologies specifically disclaims the implied warranties of merchantability and fitness for a particular purpose.

Exclusive Remedies

The remedies provided herein are buyer's sole and exclusive remedies. Keysight Technologies shall not be liable for any direct, indirect, special, incidental, or consequential damages, whether based on contract, tort, or any other legal theory.

Assistance

Product maintenance agreements and other customer assistance agreements are available for Keysight Technologies products.

For any assistance, contact your nearest Keysight Technologies Sales and Service Office. Addresses are provided at the back of this manual.

Safety Symbol

General definitions of safety symbols used on the instrument or in manuals are listed below.



Instruction Manual symbol: the product is marked with this symbol when it is necessary for the user to refer to the instrument manual.

WARNING

This warning sign denotes a hazard. It calls attention to a procedure, practice, condition or the like, which, if not correctly performed or adhered to, could result in injury or death to personnel.

CAUTION

This Caution sign denotes a hazard. It calls attention to a procedure, practice, condition or the like, which, if not correctly performed or adhered to, could result in damage to or destruction of part or all of the product.

NOTE

Note denotes important information. It calls attention to a procedure, practice, condition or the like, which is essential to highlight.

Contents

1. Operation	
Product Description	10
Specifications	11
Compensation for Fixture Residual Impedance Error	12
Operation	13
2. Service	
Maintenance	16

1 **Operation**

This operating note provides complete information on the 16048D Test Leads. The 16048D is shown pictorially in **Figure 1-1**, its physical dimensions are given in **Table 1-1**. To order additional copies of this operating note, use the part number listed on the rear cover.

Product Description

The 16048D consists of a direct attachment, 4-terminal pair type fixture which is equipped with four BNC (m) terminated-coaxial test leads. These test leads are used to attach user-fabricated test fixtures. DC bias levels of up to $\pm 42\text{V}$ can be applied to the 16048D. Cable length is 2 meter. The 16048D is shown in [Figure 1-1](#).

Figure 1-1

Product Overview

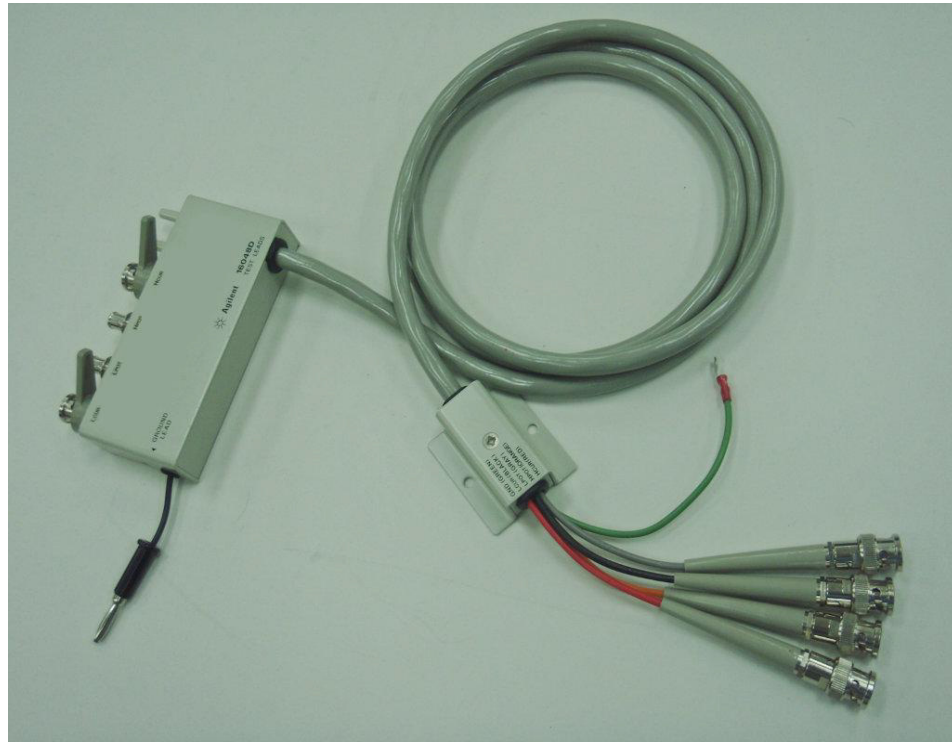

Specifications

Table 1-1 **Specifications of the 16048D**

Function:	4-terminal pair type fixture which is equipped with four BNC (m) terminated-coaxial test leads.
Connector Type:	BNC male
Maximum Voltage:	± 42 V peak max. (AC+DC)
Frequency Range:	DC to 30 MHz
Cable Length:	2m
Weight:	460 g
Safety Standards:	EN61010-1:1993 +A2:1995 IEC61010-1:1990 +A1:1992 +A2:1995 CSA C22.2 No.1010.1:1992 INSTALLATION CATEGORY I POLLUTION DEGREE 2 INDOOR USE

Compensation for Fixture Residual Impedance Error

The 16048D has inherent stray capacitance, residual inductance, and residual resistance that affect the accuracy of measured values. To compensate for, or negate, these residuals to minimize measurement error, the instrument's Open/Short compensation procedure should be performed. The procedure is given in the instrument's operating manual.

Operation

Setup and measurement procedure is as follows:

1. Connect the 16048D directly to the UNKNOWN terminals of the instrument.
2. Connect the user-fabricated test fixture to the test leads.
3. Perform Open/Short compensation as described in the instrument's operation manual.
4. Connect the DUT to the test fixture.

NOTE

Connect the green lead to the chassis or grounded part on the test fixture to reduce the effects of stray capacitance between the DUT and the test fixture.

Operation
Operation

2 **Service**

Maintenance

An exploded view of the 16048D (for parts identification) is shown in [Figure 2-1](#). Do not disassemble any further than shown. Maintenance consists principally of cleaning contacts and replacing worn or damaged parts. Take special care when cleaning contacts. To order parts, use the Keysight Technologies part numbers listed in [Table 2-1](#). If a faulty part is located in an assembly that cannot be disassembled, order the next higher assembly or return the whole device to the nearest Keysight Technologies Sales/Service Office for repair or replacement.

Figure 2-1 Parts Identification

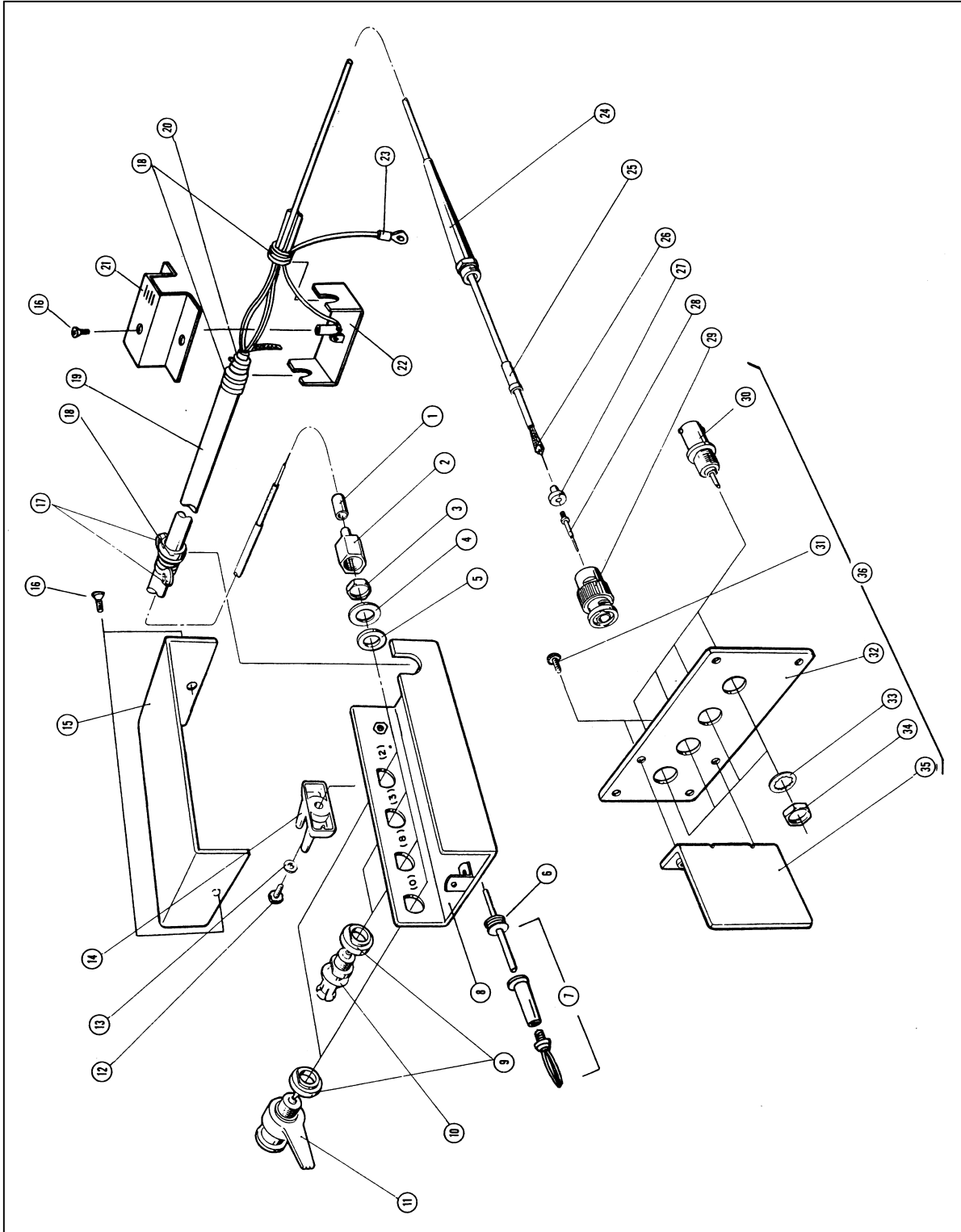

Service
Maintenance

Table 2-1

Parts Identification

Reference	Keysight Part No.	Qty.	Description
1	*	4	SLEEVE-METAL
2	*	4	NUT
3	*	4	NUT-HEX
4	*	4	WASHER-FL MTLC
5	*	4	WASHER-FL NM
6	0400-0203	1	GROMMET-RND
7	16048-61612	1	WIRE ASSEMBLY
8	*	1	BOTTOM COVER
9	*	4	INSULATOR
10	*	2	CONNECTOR-BNC
11	*	2	BNC-ASSEMBLY
12	2200-0103	1	SCREW-MACH 4-40
13	2190-0206	1	WASHER-FL MTLC
14	16047-40000	1	STOPPER
15	16048-04011	1	TOP COVER
16	2360-0192	3	SCREW-MACH 6-32
17	1400-0719	2	CABLE TIE
18	*	3	GROMMET-RND
19	*	1	CABLE SHIELDED
20	1400-0493	1	CABLE TIE
21	16048-04013	1	TOP COVER
22	16048-04014	1	BOTTOM COVER
23	16048-61611	1	CABLE ASSEMBLY
24	*	4	BNC-BOOT
25	*	4	SLEEVE
26	*	4	SLEEVE-FLEX .081ID
27	*	4	INSULATOR
28	1250-0089	4	CONTACT RF CONN
29	1250-0052	4	CONNECTOR-RF BNC

Reference	Keysight Part No.	Qty.	Description
	16048-60020	1	TEST LEAD (1 thru 29)
30	1250-0118	4	CONNECTOR-RF BNC
31	2360-0115	2	SCREW-MACH 6-32
32	16032-10021	1	PLATE
33	2190-0016	4	WASHER-LK INTL T
34	2950-0001	4	NUT-HEX
35	16032-10022	1	PLATE SHIELD
36	16032-60001	1	BNC BRACKET (30 thru 35)

*: Not separately replaceable. Order 16048-60020

Service
Maintenance

This information is subject to change without notice.

© Keysight Technologies 1990 - 2014

Edition 6, November 2014



16048-90031
www.keysight.com