

W12-3 Photoelectric Sensors

More robust, more accurate, more intelligent

W12-3 – best performance in a metal housing, offering a clear advantage over conventional opto-electronic sensors in terms of object detection, survival in industrial environments and sensor monitoring.

W12-3 reliably operates under any ambient conditions, in the temperature range from $-40\text{ }^{\circ}\text{C}$ to $+60\text{ }^{\circ}\text{C}$. W12-3 meets the requirements of IP 69K protection. The ECOLAB test proves its high resistance to detergents and disinfectants. Unwanted ambient light sources such as ceiling lights and optical reflections are identified, assessed and suppressed. W12-3 is protected effectively from electromagnetic fields.

W12-3 adapts to your system. Rotatable plug or cable connections provides increased mounting options, whilst common design features, such as dovetail mounting, permit maximum flexibility in selecting sensors. Thanks to its slim-line housing design, the W12-3 is easy to integrate.

Commissioning a W12-3 is quick and easy. The easily visible 360° status LEDs are useful aids to sensor diagnostics during commissioning, adjustment or when in operation. The scanning distance is adjusted either traditionally using potentiometers, or via Teach-in. Place object in the beam path, press button, ready.

WT12-3 with IO Link offers expandable diagnostics. For example, the scanner can be parametrized and monitored via field bus connection, allowing reduced downtime during product changeovers.

W12-3: convincing through variety. Top sensor technology, ideally adapted to the individual application, provides solutions to a wide range of Automation technology tasks. Whether in the packaging, pharmaceutical, bottling or printing industry, W12-3 is always the right choice.

Scanning distance
30 ... 175 mm

Photoelectric proximity sensor

- Robust metal housing with dovetail mounting clamps
- High device availability in industrial environments; in case of ambient light, optical reflections and devices mounted opposite one another
- Range between -40 °C ... +60 °C

Dimensional drawing

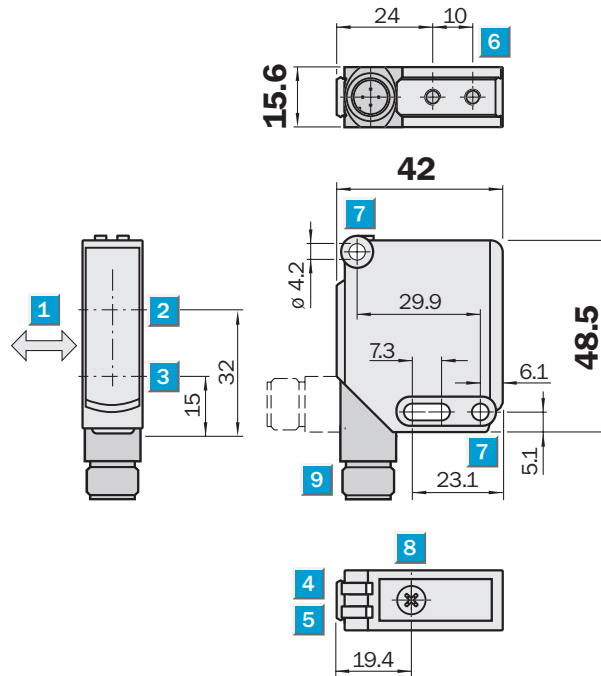

Adjustments possible

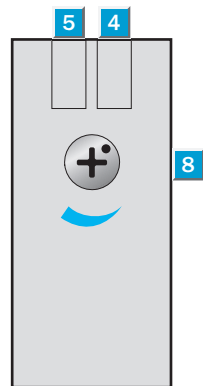

- 1 Preferred direction of the objects to be detected
- 2 Optical axis, receiver
- 3 Optical axis, sender
- 4 LED indicator green, supply voltage active
- 5 LED indicator yellow, status: light reception
- 6 Mounting thread M4 – 4 mm deep
- 7 Mounting thread, Ø 4.2 mm
- 8 Scanning distance adjuster, potentiometer
- 9 Connection



Connection type

WTF12-3N2431	WTF12-3N1131
WTF12-3P2431	WTF12-3P1131

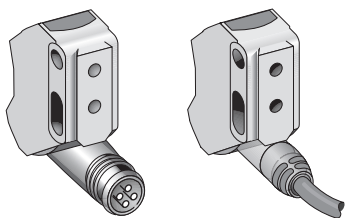

M12, 4-pin 4 x 0.25 mm²

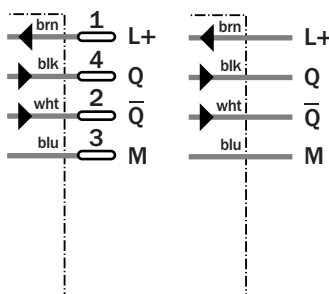

Accessories

Connector, M12, 4-pin
Mounting systems



Technical data		WTF12-3	N1131	N2431	P1131	P2431							
Scanning distance typ. max.	30 ... 175 mm ¹⁾												
Operating distance	30 ... 175 mm ¹⁾												
Adjustment of operating distance	Potentiometer (5 turn)												
Light source, light type	LED, Red light, 640 nm ²⁾												
Light spot diameter	Ø 2.0 mm at 60 mm distance												
Supply voltage V _s	DC 10 ... 30 V ³⁾												
Ripple	≤ 5 V _{pp} ⁴⁾												
Power consumption	≤ 45 mA ⁵⁾												
Switching outputs	NPN antivalent												
	PNP antivalent												
Signal voltage PNP HIGH/LOW	> V _s - 2.5 V/approx. 0 V												
Signal voltage NPN HIGH/LOW	Approx. > V _s / $<$ 2.5 V												
Output current I _a max	100 mA												
Response time	≤ 330 μs ⁶⁾												
Switching frequency	1,500 Hz ⁷⁾												
Connection type	Cable, PVC, 2 m ⁸⁾												
	Connector, M12, 4-pin												
VDE protection class	□ ⁹⁾												
Circuit protection	V _s connections reverse-polarity protected/All outputs short-circuit protected/Interference suppression												
Enclosure rating	IP 66, IP 67, IP 69 K												
Ambient temperature operation	-40 °C ... +60 °C												
Ambient temperature storage	-40 °C ... +75 °C												
Weight	Approx. 200 g												
	Approx. 120 g												
Housing material	Zinc die-cast ¹⁰⁾												

1) Object with 90 % remission (based on standard white to DIN 5033)
 2) Average service life 100,000 h at T_a = +25 °C
 3) Limit values, operation in short-circuit protected network max. 8 A
 4) May not exceed or fall short of V_s tolerances
 5) Without load
 6) Signal transit time with resistive load
 7) Typ. max. value with light/dark ratio 1:1
 8) Do not bend below 0 °C
 9) Reference voltage 50 V DC
 10) Teflon-coated housing available on request

Scanning distance

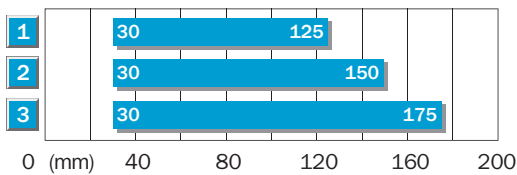

- 1 Scanning distance on black, 6 % Remission
- 2 Scanning distance on grey, 18 % Remission
- 3 Scanning distance on white, 90 % Remission

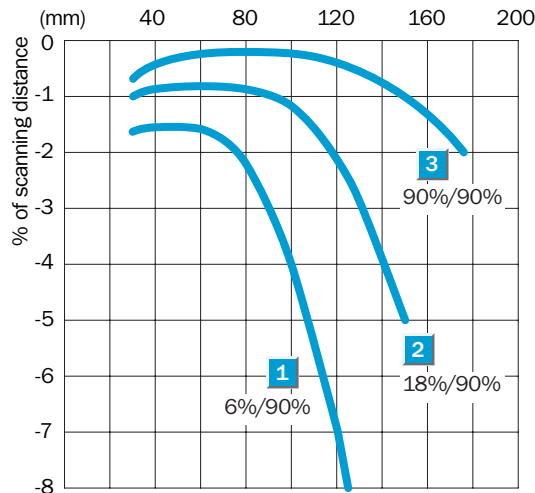

Order information	
Type	Order no.
WTF12-3N1131	1041410
WTF12-3N2431	1041408
WTF12-3P1131	1041406
WTF12-3P2431	1041404

Scanning distance
30 ... 175 mm

Photoelectric proximity sensor

- Robust metal housing with dovetail mounting clamps
- High device availability in industrial environments; in case of ambient light, optical reflections and devices mounted opposite one another
- Range between -40 °C ... +60 °C

Dimensional drawing

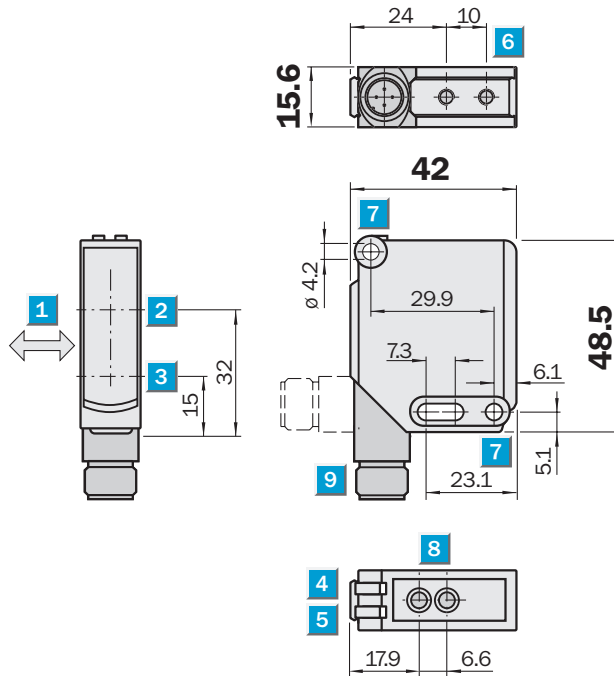

Adjustments possible

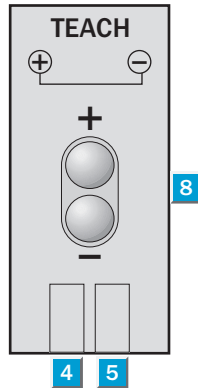

- 1 Preferred direction of the objects to be detected
- 2 Optical axis, receiver
- 3 Optical axis, sender
- 4 LED indicator green, supply voltage active
- 5 LED indicator yellow, status: light reception
- 6 Mounting thread M4 – 4 mm deep
- 7 Mounting thread, Ø 4.2 mm
- 8 Scanning distance adjuster, Teach-in: double teach button
- 9 Connection

Connection type

- WTF12-3N2433
- WTF12-3P2433

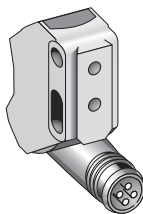

M12, 4-pin

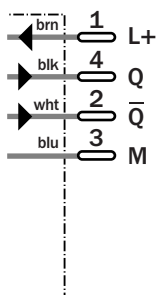

Accessories

Connector, M12, 4-pin
Mounting systems

Technical data		WTF12-3	N2433	P2433										
Scanning distance typ. max.	30 ... 175 mm ¹⁾													
Operating distance	30 ... 175 mm ¹⁾													
Adjustment of operating distance	Teach-in: double teach button													
Light source, light type	LED, Red light, 640 nm ²⁾													
Light spot diameter	Ø 2.0 mm at 60 mm distance													
Supply voltage V _s	DC 10 ... 30 V ³⁾													
Ripple	≤ 5 V _{pp} ⁴⁾													
Power consumption	≤ 45 mA ⁵⁾													
Switching outputs	NPN antivalent													
	PNP antivalent													
Signal voltage PNP HIGH/LOW	> V _s - 2.5 V/approx. 0 V													
Signal voltage NPN HIGH/LOW	Approx. > V _s / $<$ 2.5 V													
Output current I _a max	100 mA													
Response time	≤ 330 μs ⁶⁾													
Switching frequency	1,500 Hz ⁷⁾													
Connection type	Connector, M12, 4-pin													
VDE protection class	□ ⁸⁾													
Circuit protection	V _s connections reverse-polarity protected/All outputs short-circuit protected/Interference suppression													
Enclosure rating	IP 66, IP 67													
Ambient temperature operation	-40 °C ... +60 °C													
Ambient temperature storage	-40 °C ... +75 °C													
Weight	Approx. 120 g													
Housing material	Zinc die-cast ⁹⁾													

¹⁾ Object with 90 % remission (based on standard white to DIN 5033)

²⁾ Average service life 100,000 h at T_a = +25 °C

³⁾ Limit values, operation in short-circuit protected network max. 8 A

⁴⁾ May not exceed or fall short of V_s tolerances

⁵⁾ Without load

⁶⁾ Signal transit time with resistive load

⁷⁾ Typ. max. value with light/dark ratio 1:1

⁸⁾ Reference voltage 50 V DC

⁹⁾ Teflon-coated housing available on request

Teach-in procedure via double-teach button

1. Position the background in the path of the beam.
2. Press both buttons simultaneously (for approx. 2 seconds) until the yellow LED flashes = background in focus.
In the event of button activation of less than 2 seconds, the Teach command is not effective, therefore providing no protection against further unwanted manipulation.
3. Release buttons; yellow LED illuminates continuously = background is positively detected.
4. Fine adjustments can be made to the scanning distance, when required by the application: Pressing the "+" button (approx. 0.5 sec) = scanning distance will be increased. Pressing the "-" button (approx. 0.5 sec) = scanning distance will be decreased. In the event of button activation less than 0.5 sec, no change to the scanning distance is made. Upon activation of the button, the yellow LED flashes.
5. The Teach-in scanning distance is stored in the memory.

Scanning distance

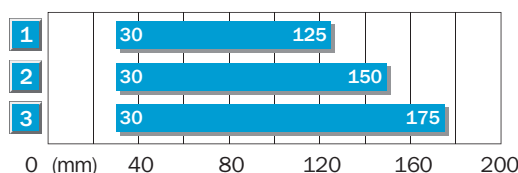

1	Scanning distance on black, 6 % Remission
2	Scanning distance on grey, 18 % Remission
3	Scanning distance on white, 90 % Remission

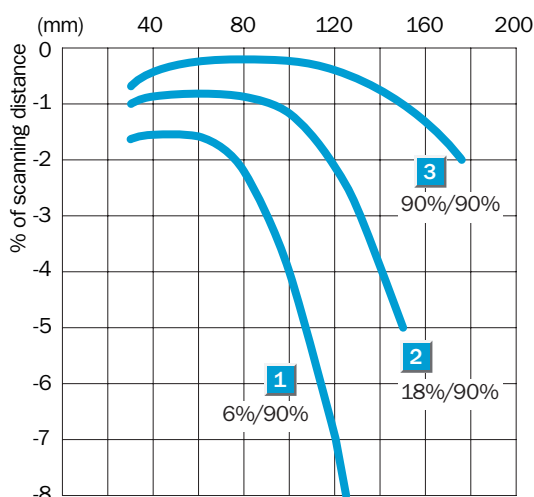

Order information

Type	Order no.
WTF12-3N2433	1041409
WTF12-3P2433	1041405

Scanning distance
30 ... 175 mm

Photoelectric proximity sensor

- Robust metal housing with dovetail mounting clamps
- High device availability in industrial environments; in case of ambient light, optical reflections and devices mounted opposite one another
- Range between -40 °C ... +60 °C
- Parameters and diagnostics via IO Link

Dimensional drawing

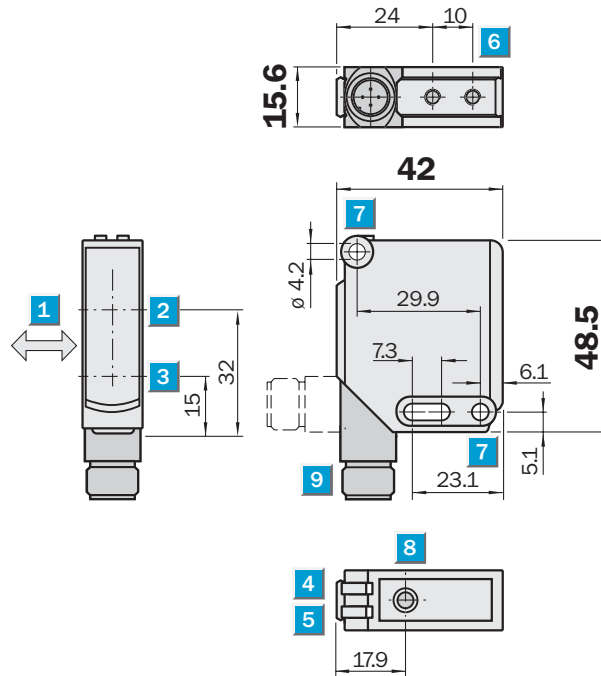

Adjustments possible

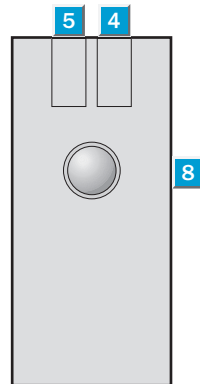

- 1 Preferred direction of the objects to be detected
- 2 Optical axis, receiver
- 3 Optical axis, sender
- 4 LED indicator green, supply voltage active
- 5 LED indicator yellow, status: light reception
- 6 Mounting thread M4 – 4 mm deep
- 7 Mounting thread, Ø 4.2 mm
- 8 Scanning distance adjuster, Teach-in: single teach button
- 9 Connection



Connection type

WTF12C-3P2433

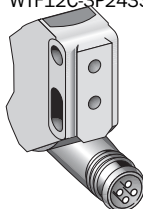

M12, 4-pin

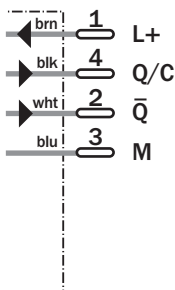

Accessories

- Connector, M12, 4-pin
- Mounting systems



Technical data		WTF12C-3	P2433										
Scanning distance typ. max.	30 ... 175 mm ¹⁾												
Operating distance	30 ... 175 mm ¹⁾												
Adjustment of operating distance	Teach-in: single-teach button Teach-in: via IO Link												
Communication mode	COM2												
Light source, light type	LED, Red light, 660 nm ²⁾												
Light spot diameter	Ø 2 mm at 60 mm distance												
Supply voltage V _s	DC 10 ... 30 V ³⁾												
Ripple	≤ 5 V _{pp} ⁴⁾												
Power consumption	≤ 30 mA ⁵⁾												
Switching outputs	PNP, Q/C PNP, not Q												
Signal voltage PNP HIGH/LOW	> V _s - 2.5 V/approx. 0 V												
Output current I _a max	100 mA												
Response time	≤ 330 µs ⁶⁾												
Switching frequency	1,500 Hz ⁷⁾												
Connection type	Connector, M12, 4-pin												
VDE protection class	□ ⁸⁾												
Circuit protection	V _s connections reverse-polarity protected/ All outputs short-circuit protected/ Interference suppression												
Enclosure rating	IP 66, IP 67												
Ambient temperature operation	-40 °C ... +60 °C												
Ambient temperature storage	-40 °C ... +75 °C												
Weight	Approx. 120 g												
Housing material	Zinc die-cast												

1) Object with 90 % remission (based on standard white to DIN 5033)
 2) Average service life 100,000 h at T_a = +25 °C
 3) Limit values, operation in short-circuit protected network max. 8 A
 4) May not exceed or fall short of V_s tolerances
 5) Without load
 6) Signal transit time with resistive load. Different values possible in COM2 mode.
 7) Typ. max. value with light/dark ratio 1:1 in switching mode. Different values possible in COM2 mode.
 8) Reference voltage 50 V DC

Teach-in procedure via single-teach button

1. Position the background in the path of the beam.
2. Press teach button (for approx. 2 seconds) until the yellow LED flashes = background in focus. In the event of button activation of less than 2 seconds, the Teach command is not effective, therefore providing no protection against further unwanted manipulation.
3. Release button; yellow LED illuminates continuously = background is positively detected.

Scanning distance

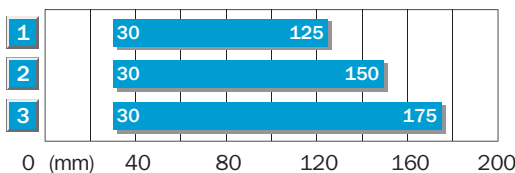

- 1 Scanning distance on black, 6 % Remission
- 2 Scanning distance on grey, 18 % Remission
- 3 Scanning distance on white, 90 % Remission

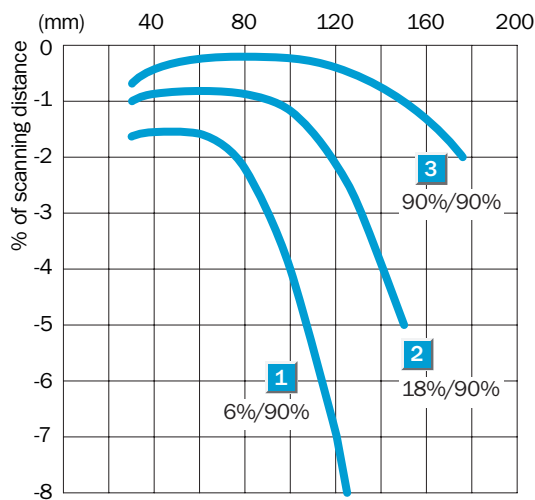

Order information	
Type	Order no.
WTF12C-3P2433	1042001

Scanning distance
30 ... 500 mm

Photoelectric proximity sensor

- Robust metal housing with dovetail mounting clamps
- High device availability in industrial environments; in case of ambient light, optical reflections and devices mounted opposite one another
- Range between -40 °C ... +60 °C

Dimensional drawing

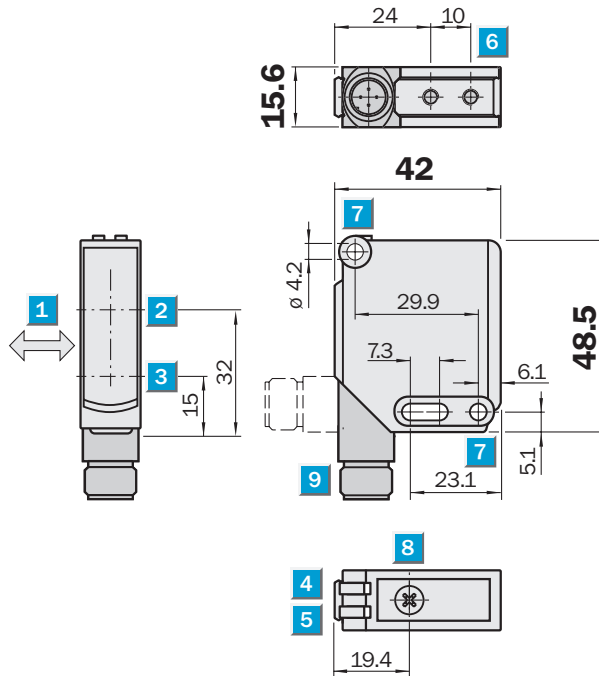

Adjustments possible

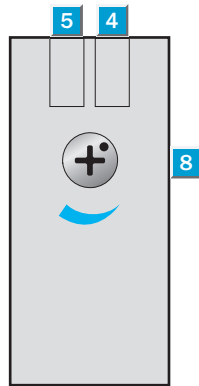

- 1 Preferred direction of the objects to be detected
- 2 Optical axis, receiver
- 3 Optical axis, sender
- 4 LED indicator green, supply voltage active
- 5 LED indicator yellow, status: light reception
- 6 Mounting thread M4 – 4 mm deep
- 7 Mounting thread, Ø 4.2 mm
- 8 Scanning distance adjuster, potentiometer
- 9 Connection



Connection type

WTF12-3N2441	WTF12-3P1141
WTF12-3P2441	

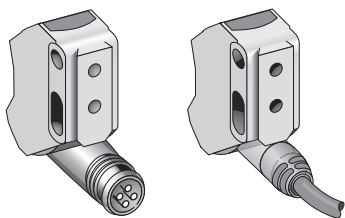

M12, 4-pin	4 x 0.25 mm ²
------------	--------------------------

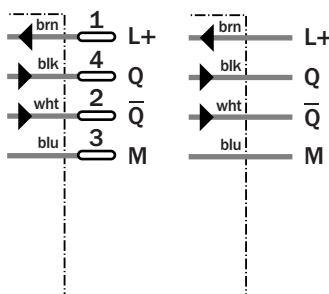

Accessories

Connector, M12, 4-pin
Mounting systems



Technical data		WTF12-3	N2441	P1141	P2441								
Scanning distance typ. max.	30 ... 500 mm ¹⁾												
Operating distance	30 ... 500 mm ¹⁾												
Adjustment of operating distance	Potentiometer (5 turn)												
Light source, light type	LED, Red light, 640 nm ²⁾												
Light spot diameter	Ø 7.0 mm at 300 mm distance												
Supply voltage V _s	DC 10 ... 30 V ³⁾												
Ripple	≤ 5 V _{pp} ⁴⁾												
Power consumption	≤ 45 mA ⁵⁾												
Switching outputs	NPN antivalent												
	PNP antivalent												
Signal voltage PNP HIGH/LOW	> V _s - 2.5 V/approx. 0 V												
Signal voltage NPN HIGH/LOW	Approx. > V _s / $<$ 2.5 V												
Output current I _a max	100 mA												
Response time	≤ 330 μs ⁶⁾												
Switching frequency	1,500 Hz ⁷⁾												
Connection type	Connector, M12, 4-pin												
	Cable, PVC, 2 m ⁸⁾												
VDE protection class	□ ⁹⁾												
Circuit protection	V _s connections reverse-polarity protected/All outputs short-circuit protected/Interference suppression												
Enclosure rating	IP 66, IP 67, IP 69 K												
Ambient temperature operation	-40 °C ... +60 °C												
Ambient temperature storage	-40 °C ... +75 °C												
Weight	Approx. 120 g												
	Approx. 200 g												
Housing material	Zinc die-cast ¹⁰⁾												

1) Object with 90 % remission (based on standard white to DIN 5033)
 2) Average service life 100,000 h at T_a = +25 °C
 3) Limit values, operation in short-circuit protected network max. 8 A
 4) May not exceed or fall short of V_s tolerances
 5) Without load
 6) Signal transit time with resistive load
 7) Typ. max. value with light/dark ratio 1:1 in switching mode
 8) Do not bend below 0 °C
 9) Reference voltage 50 V DC
 10) Teflon-coated housing available on request

Scanning distance

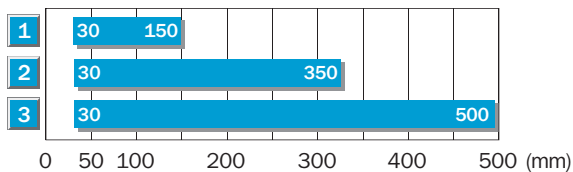

- 1 Scanning distance on black, 6 % Remission
- 2 Scanning distance on grey, 18 % Remission
- 3 Scanning on white, 90 % Remission

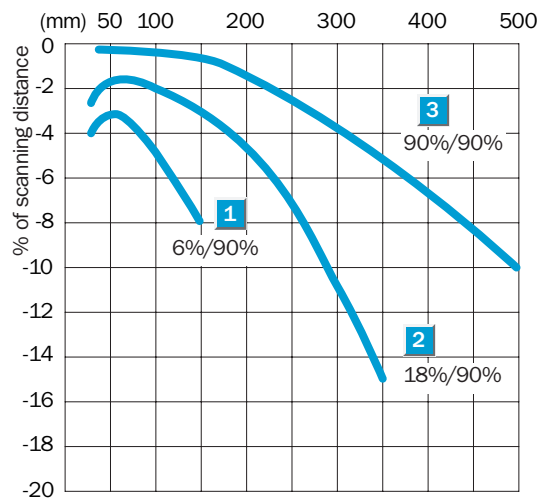

Order information	
Type	Order no.
WTF12-3N2441	1041403
WTF12-3P1141	1041402
WTF12-3P2441	1041400

Photoelectric proximity sensor, WTF12-3, FGS, red light, Teach-in, long range

Scanning distance
30 ... 500 mm

Photoelectric proximity sensor

- Robust metal housing with dovetail mounting clamps
- High device availability in industrial environments; in case of ambient light, optical reflections and devices mounted opposite one another
- Range between -40 °C ... +60 °C

Dimensional drawing

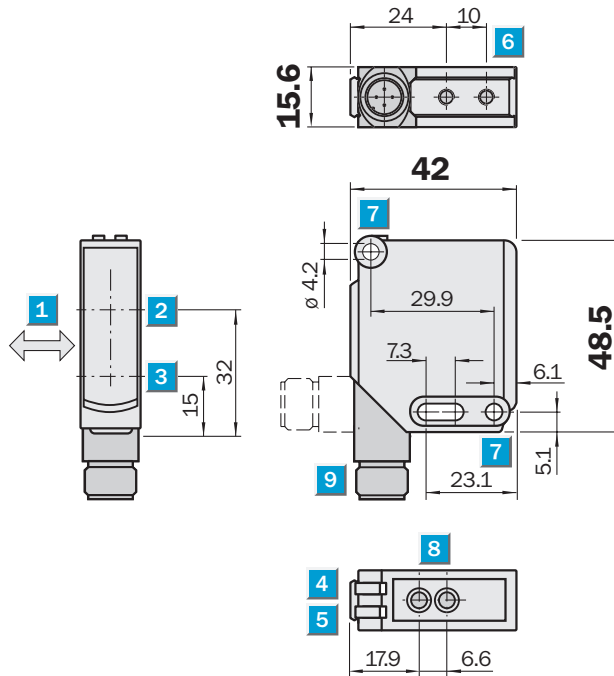

Adjustments possible

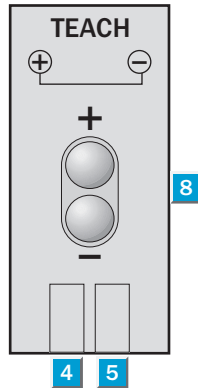

- 1 Preferred direction of the objects to be detected
- 2 Optical axis, receiver
- 3 Optical axis, sender
- 4 LED indicator green, supply voltage active
- 5 LED indicator yellow, status: light reception
- 6 Mounting thread M4 – 4 mm deep
- 7 Mounting thread, Ø 4.2 mm
- 8 Scanning distance adjuster, Teach-in: double teach button
- 9 Connection

Connection type

WTF12-3P2443

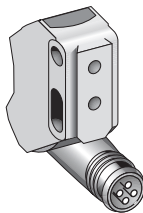

M12, 4-pin

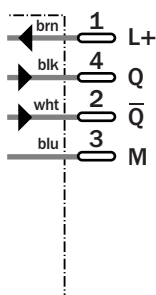

Accessories
Connector, M12, 4-pin
Mounting systems

Technical data		WTF12-3	P2443											
Scanning distance typ. max.	30 ... 500 mm ¹⁾													
Operating distance	30 ... 500 mm ¹⁾													
Adjustment of operating distance	Teach-in: double teach button													
Light source, light type	LED, Red light, 640 nm ²⁾													
Light spot diameter	Ø 7.0 mm at 300 mm distance													
Supply voltage V_s	DC 10 ... 30 V ³⁾													
Ripple	≤ 5 V _{pp} ⁴⁾													
Power consumption	≤ 45 mA ⁵⁾													
Switching outputs	PNP antivalent													
Signal voltage PNP HIGH/LOW	> V _s - 2.5 V/approx. 0 V													
Output current I _a max	100 mA													
Response time	≤ 330 µs ⁶⁾													
Switching frequency	1,500 Hz ⁷⁾													
Connection type	Connector, M12, 4-pin													
VDE protection class	□ ⁸⁾													
Circuit protection	V _s connections reverse-polarity protected/All outputs short-circuit protected/Interference suppression													
Enclosure rating	IP 66, IP 67													
Ambient temperature operation	-40 °C ... +60 °C													
Ambient temperature storage	-40 °C ... +75 °C													
Weight	Approx. 120 g													
Housing material	Zinc die-cast ⁹⁾													

1) Object with 90 % remission (based on standard white to DIN 5033)
 2) Average service life 100,000 h at T_a = +25 °C
 3) Limit values, operation in short-circuit protected network max. 8 A
 4) May not exceed or fall short of V_s tolerances
 5) Without load
 6) Signal transit time with resistive load
 7) Typ. max. value with light/dark ratio 1:1 in switching mode
 8) Reference voltage 50 V DC
 9) Teflon-coated housing available on request

Teach-in procedure via double-teach button

1. Position the background in the path of the beam.
2. Press both buttons simultaneously (**for approx. 2 seconds**) until the yellow LED flashes = background in focus.
 In the event of button activation of less than 2 seconds, the Teach command is not effective, therefore providing no protection against further unwanted manipulation.
3. Release buttons; yellow LED illuminates continuously = background is positively detected.
4. Fine adjustments can be made to the scanning distance, when required by the application: Pressing the "+" button (**approx. 0.5 sec**) = scanning distance will be increased. Pressing the "-" button (**approx. 0.5 sec**) = scanning distance will be decreased. In the event of button activation less than 0.5 sec, no change to the scanning distance is made. Upon activation of the button, the yellow LED flashes.
5. The Teach-in scanning distance is stored in the memory.

Scanning distance

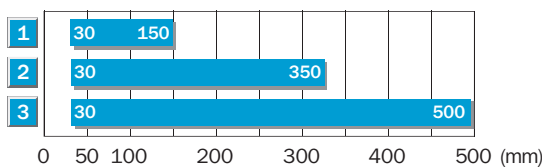

- 1 Scanning distance on black, 6 % Remission
- 2 Scanning distance on grey, 18 % Remission
- 3 Scanning on white, 90 % Remission

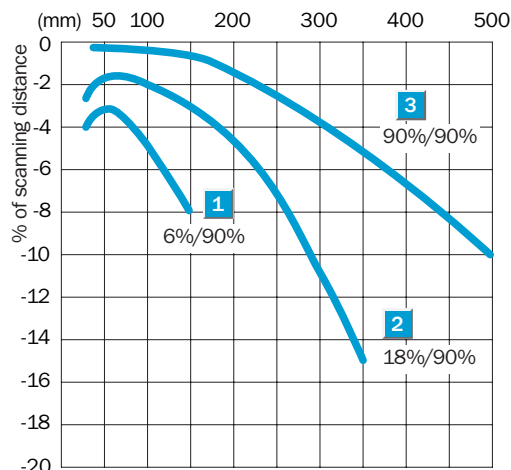

Order information	
Type	Order no.
WTF12-3P2443	1041401

Scanning distance
20 ... 350 mm

Photoelectric proximity sensor

- Robust metal housing with dovetail mounting clamps
- High device availability in industrial environments; in case of ambient light, optical reflections and devices mounted opposite one another
- Range between -40 °C ... +60 °C

Dimensional drawing

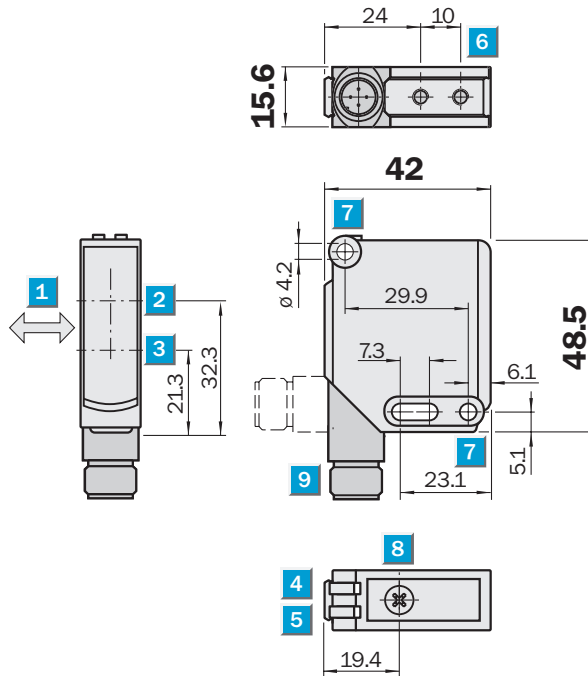

Adjustments possible

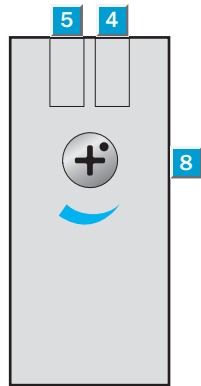

- 1 Preferred direction of the objects to be detected
- 2 Optical axis, receiver
- 3 Optical axis, sender
- 4 LED indicator green, supply voltage active
- 5 LED indicator yellow, status: light reception
- 6 Mounting thread M4 – 4 mm deep
- 7 Mounting thread, Ø 4.2 mm
- 8 Scanning distance adjuster, potentiometer
- 9 Connection

Connection type

WTB12-3N2431	WTB12-3N1131
WTB12-3P2431	WTB12-3N1231
	WTB12-3P1131
	WTB12-3P1231

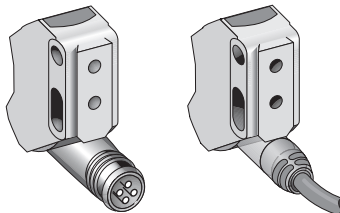

M12, 4-pin 4 x 0.25 mm²

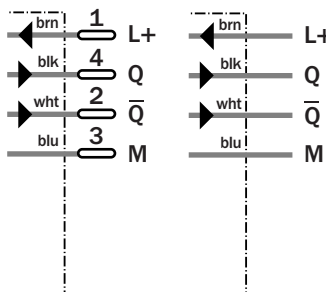

Accessories

Connector, M12, 4-pin
Mounting systems

Technical data		WTB12-3	N1131	N1231	N2431	P1131	P1231	P2431				
Scanning distance typ. max.	20 ... 350 mm ¹⁾											
Operating distance	20 ... 350 mm ¹⁾											
Adjustment of operating distance	Potentiometer (5 turn)											
Light source, light type	LED, Red light, 640 nm ²⁾											
Light spot diameter	Ø 6.0 mm at 200 mm distance											
Supply voltage V _s	DC 10 ... 30 V ³⁾											
Ripple	≤ 5 V _{pp} ⁴⁾											
Power consumption	≤ 45 mA ⁵⁾											
Switching outputs	NPN antivalent											
	PNP antivalent											
Signal voltage PNP HIGH/LOW	> V _s - 2.5 V/approx. 0 V											
Signal voltage NPN HIGH/LOW	Approx. > V _s / _{<} 2.5 V											
Output current I _a max	100 mA											
Response time	≤ 330 µs ⁶⁾											
Switching frequency	1,500 Hz ⁷⁾											
Connection type	Cable, PVC, 2 m ⁸⁾											
	Cable, PVC, 5 m ⁸⁾											
	Connector, M12, 4-pin											
VDE protection class	□ ⁹⁾											
Circuit protection	V _s connections reverse-polarity protected/All outputs short-circuit protected/Interference suppression											
Enclosure rating	IP 66, IP 67, IP 69 K											
Ambient temperature operation	-40 °C ... +60 °C											
Ambient temperature storage	-40 °C ... +75 °C											
Weight	Approx. 200 g											
	Approx. 280 g											
	Approx. 120 g											
Housing material	Zinc die-cast ¹⁰⁾											

1) Object with 90 % remission (based on standard white to DIN 5033)
 2) Average service life 100,000 h at T_a = +25 °C
 3) Limit values, operation in short-circuit protected network max. 8 A
 4) May not exceed or fall short of V_s tolerances
 5) Without load
 6) Signal transit time with resistive load
 7) Typ. max. value with light/dark ratio 1:1 in switching mode
 8) Do not bend below 0 °C
 9) Reference voltage 50 V DC
 10) Teflon-coated housing available on request

Scanning distance

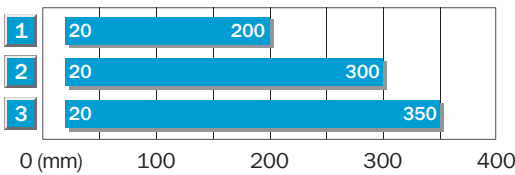

- 1 Scanning distance on black, 6 % Remission
- 2 Scanning distance on grey, 18 % Remission
- 3 Scanning on white, 90 % Remission

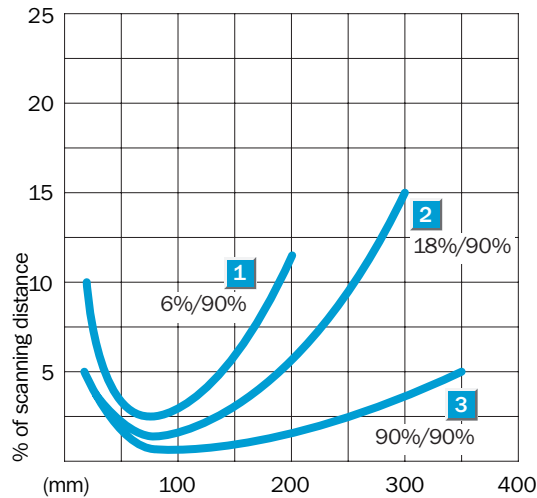

Order information	
Type	Order no.
WTB12-3N1131	1041418
WTB12-3N1231	1041419
WTB12-3N2431	1041416
WTB12-3P1131	1041413
WTB12-3P1231	1041415
WTB12-3P2431	1041411

Scanning distance
20 ... 350 mm

Photoelectric proximity sensor

- Robust metal housing with dovetail mounting clamps
- High device availability in industrial environments; in case of ambient light, optical reflections and devices mounted opposite one another
- Range between -40 °C ... +60 °C

Dimensional drawing

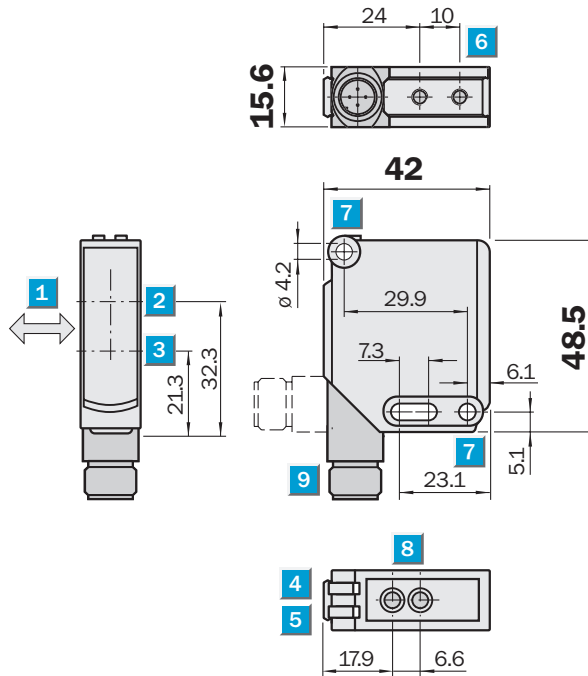

Adjustments possible

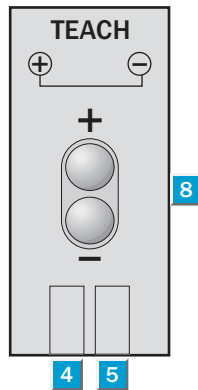

- 1 Preferred direction of the objects to be detected
- 2 Optical axis, receiver
- 3 Optical axis, sender
- 4 LED indicator green, supply voltage active
- 5 LED indicator yellow, status: light reception
- 6 Mounting thread M4 – 4 mm deep
- 7 Mounting thread, Ø 4.2 mm
- 8 Scanning distance adjuster, Teach-in: double teach button
- 9 Connection



Connection type

- WTB12-3N2433
- WTB12-3P2433

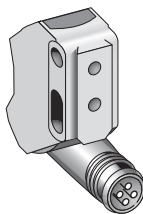

M12, 4-pin

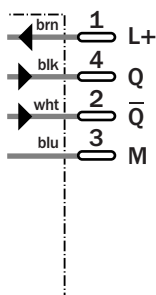

Accessories

Connector, M12, 4-pin
Mounting systems

Technical data		WTB12-3	N2433	P2433									
Scanning distance typ. max.	20 ... 350 mm ¹⁾												
Operating distance	20 ... 350 mm ¹⁾												
Adjustment of operating distance	Teach-in: double teach button												
Light source, light type	LED, Red light, 640 nm ²⁾												
Light spot diameter	Ø 6.0 mm at 200 mm distance												
Supply voltage V _s	DC 10 ... 30 V ³⁾												
Ripple	≤ 5 V _{pp} ⁴⁾												
Power consumption	≤ 45 mA ⁵⁾												
Switching outputs	NPN antivalent												
	PNP antivalent												
Signal voltage PNP HIGH/LOW	> V _s - 2.5 V/approx. 0 V												
Signal voltage NPN HIGH/LOW	Approx. > V _s / $<$ 2.5 V												
Output current I _a max	100 mA												
Response time	≤ 330 μs ⁶⁾												
Switching frequency	1,500 Hz ⁷⁾												
Connection type	Connector, M12, 4-pin												
VDE protection class	□ ⁸⁾												
Circuit protection	V _s connections reverse-polarity protected/All outputs short-circuit protected/Interference suppression												
Enclosure rating	IP 66, IP 67												
Ambient temperature operation	-40 °C ... +60 °C												
Ambient temperature storage	-40 °C ... +75 °C												
Weight	Approx. 120 g												
Housing material	Zinc die-cast ⁹⁾												

¹⁾ Object with 90 % remission (based on standard white to DIN 5033)

²⁾ Average service life 100,000 h at T_a = +25 °C

³⁾ Limit values, operation in short-circuit protected network max. 8 A

⁴⁾ May not exceed or fall short of V_s tolerances

⁵⁾ Without load

⁶⁾ Signal transit time with resistive load

⁷⁾ Typ. max. value with light/dark ratio 1:1 in switching mode

⁸⁾ Reference voltage 50 V DC

⁹⁾ Teflon-coated housing available on request

Teach-in procedure via double-teach button

1. Position the object in the path of the beam.
2. Press both buttons simultaneously (for approx. 2 seconds) until the yellow LED flashes = object in focus.
In the event of button activation of less than 2 seconds, the Teach command is not effective, therefore providing no protection against further unwanted manipulation.
3. Release buttons; yellow LED illuminates continuously = object is positively detected.
4. Fine adjustments can be made to the scanning distance, when required by the application: Pressing the "+" button (approx. 0.5 sec) = scanning distance will be increased. Pressing the "-" button (approx. 0.5 sec) = scanning distance will be decreased. In the event of button activation less than 0.5 sec, no change to the scanning distance is made. Upon activation of the button, the yellow LED flashes.
5. The Teach-in scanning distance is stored in the memory.

Scanning distance

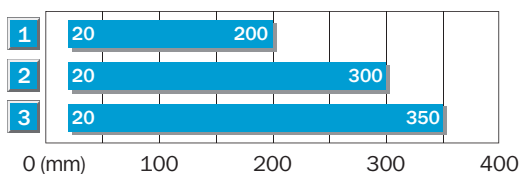

1	Scanning distance on black, 6 % Remission
2	Scanning distance on grey, 18 % Remission
3	Scanning distance on white, 90 % Remission

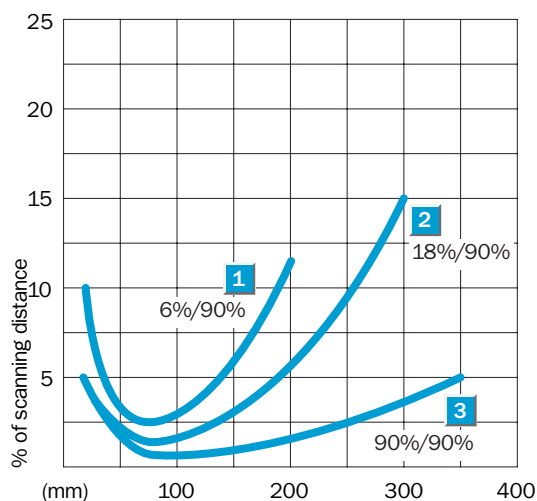

Order information

Type	Order no.
WTB12-3N2433	1041417
WTB12-3P2433	1041412

Scanning distance
20 ... 350 mm

Photoelectric proximity sensor

- Robust metal housing with dovetail mounting clamps
- High device availability in industrial environments; in case of ambient light, optical reflections and devices mounted opposite one another
- Range between -40 °C ... +60 °C
- Parameters and diagnostics via IO Link

Dimensional drawing

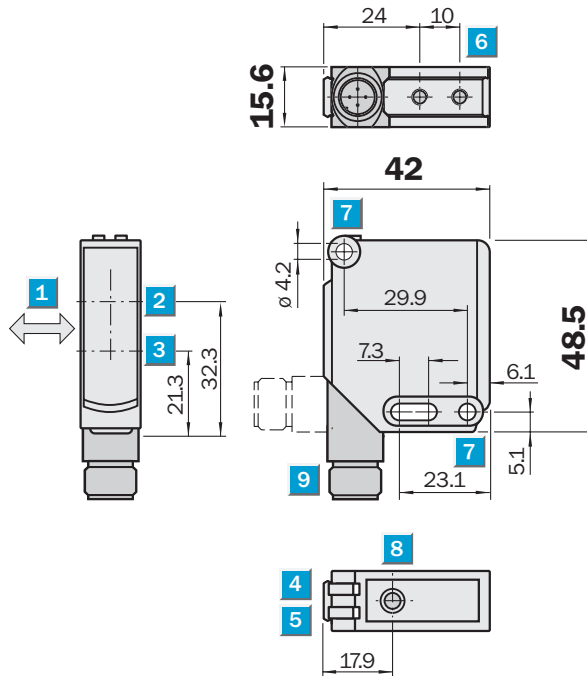

Adjustments possible

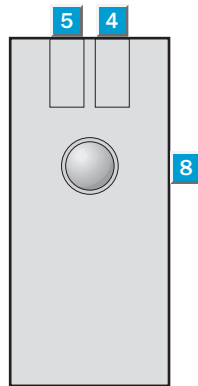

- 1 Preferred direction of the objects to be detected
- 2 Optical axis, receiver
- 3 Optical axis, sender
- 4 LED indicator green, supply voltage active
- 5 LED indicator yellow, status: light reception
- 6 Mounting thread M4 – 4 mm deep
- 7 Mounting thread, Ø 4.2 mm
- 8 Scanning distance adjuster, Teach-in: single teach button
- 9 Connection



Connection type

WTB12C-3P2433

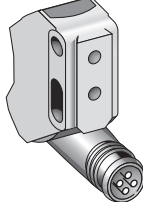

M12, 4-pin

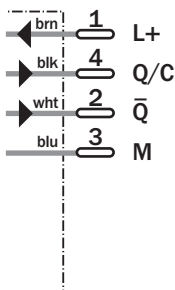

Accessories

- Connector, M12, 4-pin
- Mounting systems



Technical data		WTB12C-3	P2433											
Scanning distance typ. max.	20 ... 350 mm ¹⁾													
Operating distance	20 ... 350 mm ¹⁾													
Adjustment of operating distance	Teach-in: single-teach button Teach-in: via IO Link													
Communication mode	COM2													
Light source, light type	LED, Red light, 660 nm ²⁾													
Light spot diameter	Approx. 6 mm at 200 mm distance													
Supply voltage V _s	DC 10 ... 30 V ³⁾													
Ripple	≤ 5 V _{pp} ⁴⁾													
Power consumption	≤ 30 mA ⁵⁾													
Switching outputs	PNP, Q/C PNP, not Q													
Signal voltage PNP HIGH/LOW	> V _s - 2.5 V/approx. 0 V													
Output current I _a max	100 mA													
Response time	≤ 330 μs ⁶⁾													
Switching frequency	1,500 Hz ⁷⁾													
Connection type	Connector, M12, 4-pin													
VDE protection class	□ ⁸⁾													
Circuit protection	V _s connections reverse-polarity protected/All outputs short-circuit protected/Interference suppression													
Enclosure rating	IP 66, IP 67													
Ambient temperature operation	-40 °C ... +60 °C													
Ambient temperature storage	-40 °C ... +75 °C													
Weight	Approx. 120 g													
Housing material	Zinc die-cast													

1) Object with 90 % remission (based on standard white to DIN 5033)
 2) Average service life 100,000 h at T_a = +25 °C
 3) Limit values, operation in short-circuit protected network max. 8 A
 4) May not exceed or fall short of V_s tolerances
 5) Without load
 6) Signal transit time with resistive load in switching mode. Different values possible in COM2 mode.
 7) Typ. max. value with light/dark ratio 1:1 in switching mode. Different values possible in COM2 mode.
 8) Reference voltage 50 V DC

Teach-in procedure via single-teach button

1. Position the object in the path of the beam.
2. Press teach button (for approx. 2 seconds) until the yellow LED flashes = object in focus. In the event of button activation of less than 2 seconds, the Teach command is not effective, therefore providing no protection against further unwanted manipulation.
3. Release button; yellow LED illuminates continuously = object is positively detected.

Scanning distance

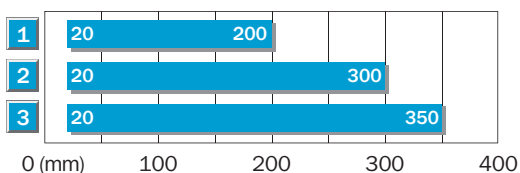

- 1 Scanning distance on black, 6 % Remission
- 2 Scanning distance on grey, 18 % Remission
- 3 Scanning on white, 90 % Remission

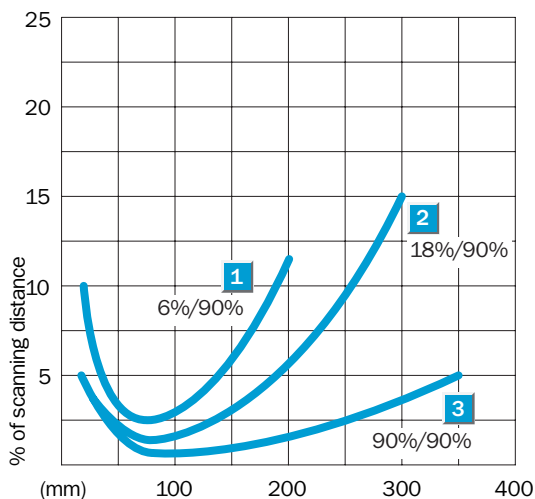

Order information	
Type	Order no.
WTB12C-3P2433	1042002

Scanning distance
20 ... 600 mm

Photoelectric proximity sensor

- Robust metal housing with dovetail mounting clamps
- High device availability in industrial environments; in case of ambient light, optical reflections and devices mounted opposite one another
- Range between -40 °C ... +60 °C

Dimensional drawing

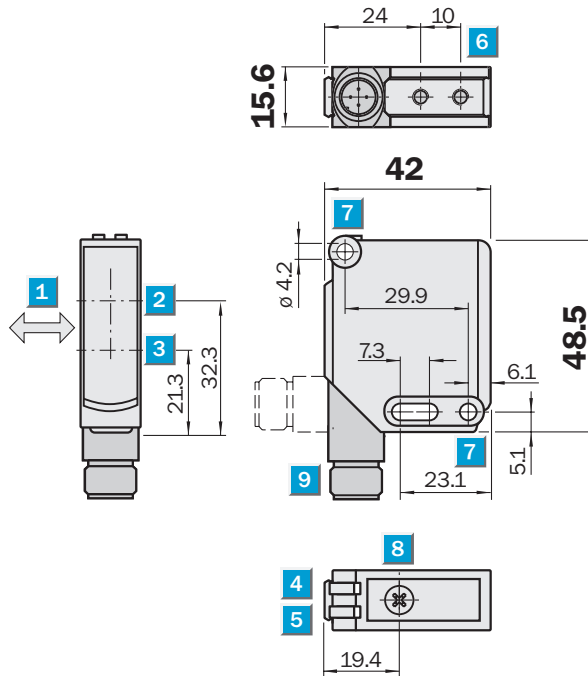

Adjustments possible

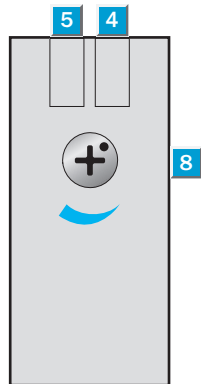

- 1 Preferred direction of the objects to be detected
- 2 Optical axis, receiver
- 3 Optical axis, sender
- 4 LED indicator green, supply voltage active
- 5 LED indicator yellow, status: light reception
- 6 Mounting thread M4 – 4 mm deep
- 7 Mounting thread, Ø 4.2 mm
- 8 Scanning distance adjuster, potentiometer
- 9 Connection

Connection type

WTB12-3N2411	WTB12-3N1711
WTB12-3P2411	WTB12-3N1111
	WTB123-P1711
	WTB12-3P1111

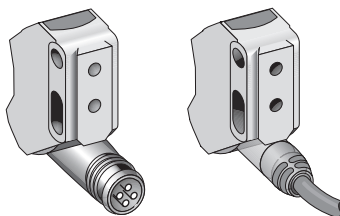

M12, 4-pin 4 x 0.25 mm²

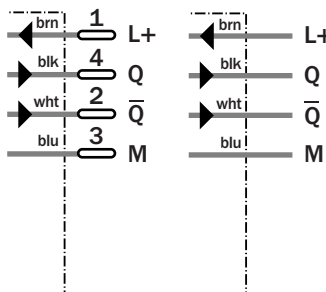

Accessories

Connector, M12, 4-pin
Mounting systems

Technical data		WTB12-3	N1711	N1111	N2411	P1711	P1111	P2411				
Scanning distance typ. max.	20 ... 600 mm ¹⁾											
Operating distance	20 ... 600 mm ¹⁾											
Adjustment of operating distance	Potentiometer (5 turn)											
Light source, light type	LED, Infrared light, 850 nm ²⁾											
Light spot diameter	Approx. 15 x 15 mm at 200 mm distance											
Supply voltage V _s	DC 10 ... 30 V ³⁾											
Ripple	≤ 5 V _{pp} ⁴⁾											
Power consumption	≤ 55 mA ⁵⁾											
Switching outputs	NPN antivalent											
	PNP antivalent											
Signal voltage PNP HIGH/LOW	> V _s - 2.5 V/ approx. 0 V											
Signal voltage NPN HIGH/LOW	Approx. > V _s / < 2.5 V											
Output current I _a max	100 mA											
Response time	≤ 330 μs ⁶⁾											
Switching frequency	1,500 Hz ⁷⁾											
Connection type	Cable, PVC, 3 m ⁸⁾											
	Cable, PVC, 2 m ⁸⁾											
	Connector, M12, 4-pin											
VDE protection class	□ ⁹⁾											
Circuit protection	V _s connections reverse-polarity protected/All outputs short-circuit protected/Interference suppression											
Enclosure rating	IP 66, IP 67, IP 69 K											
Ambient temperature operation	-40 °C ... +60 °C											
Ambient temperature storage	-40 °C ... +75 °C											
Weight	Approx. 250 g											
	Approx. 200 g											
	Approx. 120 g											
Housing material	Zinc die-cast ¹⁰⁾											

1) Object with 90 % remission (based on standard white to DIN 5033)
 2) Average service life 100,000 h at T_a = +25 °C

3) Limit values, operation in short-circuit protected network max. 8 A
 4) May not exceed or fall short of V_s tolerances

5) Without load
 6) Signal transit time with resistive load
 7) Typ. max. value with light/dark ratio 1:1 in switching mode

8) Do not bend below 0 °C
 9) Reference voltage 50 V DC
 10) Teflon-coated housing available on request

Scanning distance

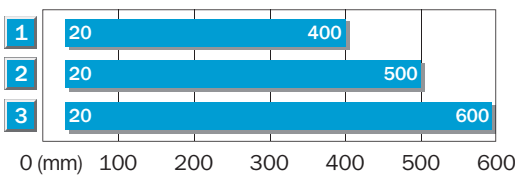

- 1 Scanning distance on black, 6 % Remission
- 2 Scanning distance on grey, 18 % Remission
- 3 Scanning on white, 90 % Remission

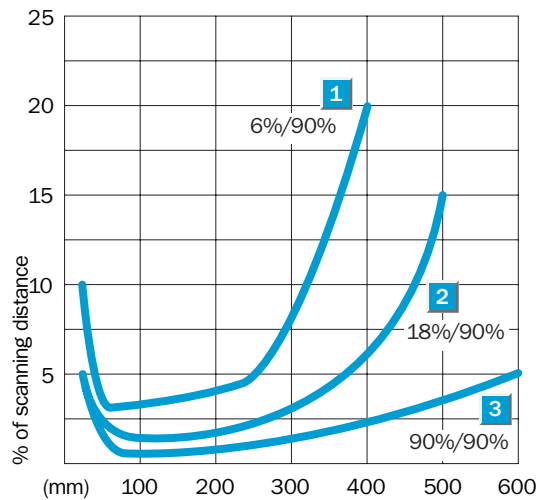

Order information	
Type	Order no.
WTB12-3N1711	1041430
WTB12-3N1111	1041429
WTB12-3N2411	1041427
WTB12-3P1711	1041426
WTB12-3P1111	1041424
WTB12-3P2411	1041422

Scanning distance
20 ... 600 mm

Photoelectric proximity sensor

- Robust metal housing with dovetail mounting clamps
- High device availability in industrial environments; in case of ambient light, optical reflections and devices mounted opposite one another
- Range between -40 °C ... +60 °C

Dimensional drawing

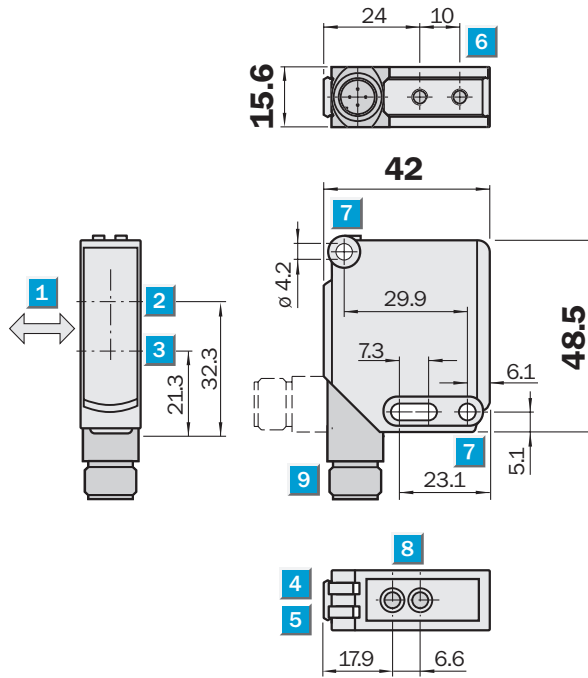

Adjustments possible

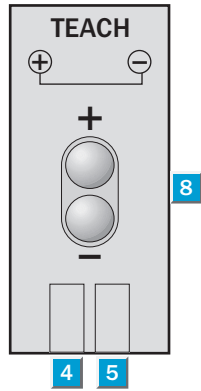

- 1 Preferred direction of the objects to be detected
- 2 Optical axis, receiver
- 3 Optical axis, sender
- 4 LED indicator green, supply voltage active
- 5 LED indicator yellow, status: light reception
- 6 Mounting thread M4 – 4 mm deep
- 7 Mounting thread, Ø 4.2 mm
- 8 Scanning distance adjuster, Teach-in: double teach button
- 9 Connection

Connection type

- WTB12-3N2413
- WTB12-3P2413

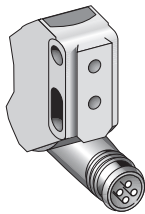

M12, 4-pin

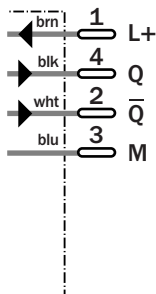

Accessories

Connector, M12, 4-pin
Mounting systems

Technical data		WTB12-3	N2413	P2413								
Scanning distance typ. max.	20 ... 600 mm ¹⁾											
Operating distance	20 ... 600 mm ¹⁾											
Adjustment of operating distance	Teach-in: double teach button											
Light source, light type	LED, Infrared light, 850 nm ²⁾											
Light spot diameter	Approx. 15 x 15 mm at 200 mm distance											
Supply voltage V _s	DC 10 ... 30 V ³⁾											
Ripple	≤ 5 V _{pp} ⁴⁾											
Power consumption	≤ 55 mA ⁵⁾											
Switching outputs	NPN antivalent											
	PNP antivalent											
Signal voltage PNP HIGH/LOW	> V _s - 2.5 V/approx. 0 V											
Signal voltage NPN HIGH/LOW	Approx. > V _s / $<$ 2.5 V											
Output current I _a max	100 mA											
Response time	≤ 330 μs ⁶⁾											
Switching frequency	1,500 Hz ⁷⁾											
Connection type	Connector, M12, 4-pin											
VDE protection class	□ ⁸⁾											
Circuit protection	V _s connections reverse-polarity protected/All outputs short-circuit protected/Interference suppression											
Enclosure rating	IP 66, IP 67											
Ambient temperature operation	-40 °C ... +60 °C											
Ambient temperature storage	-40 °C ... +75 °C											
Weight	Approx. 120 g											
Housing material	Zinc die-cast ⁹⁾											

1) Object with 90 % remission (based on standard white to DIN 5033)
 2) Average service life 100,000 h at T_a = +25 °C
 3) Limit values, operation in short-circuit protected network max. 8 A
 4) May not exceed or fall short of V_s tolerances
 5) Without load
 6) Signal transit time with resistive load
 7) Typ. max. value with light/dark ratio 1:1
 8) Reference voltage 50 V DC
 9) Teflon-coated housing available on request

Teach-in procedure via double-teach button

1. Position the object in the path of the beam.
2. Press both buttons simultaneously (for approx. 2 seconds) until the yellow LED flashes = object in focus.
 In the event of button activation of less than 2 seconds, the Teach command is not effective, therefore providing no protection against further unwanted manipulation.
3. Release buttons; yellow LED illuminates continuously = object is positively detected.
4. Fine adjustments can be made to the scanning distance, when required by the application: Pressing the "+" button (approx. 0.5 sec) = scanning distance will be increased. Pressing the "-" button (approx. 0.5 sec) = scanning distance will be decreased. In the event of button activation less than 0.5 sec, no change to the scanning distance is made. Upon activation of the button, the yellow LED flashes.
5. The Teach-in scanning distance is stored in the memory.

Scanning distance

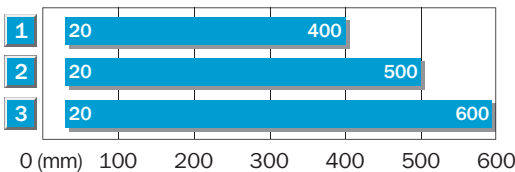

- 1 Scanning distance on black, 6 % Remission
- 2 Scanning distance on grey, 18 % Remission
- 3 Scanning on white, 90 % Remission

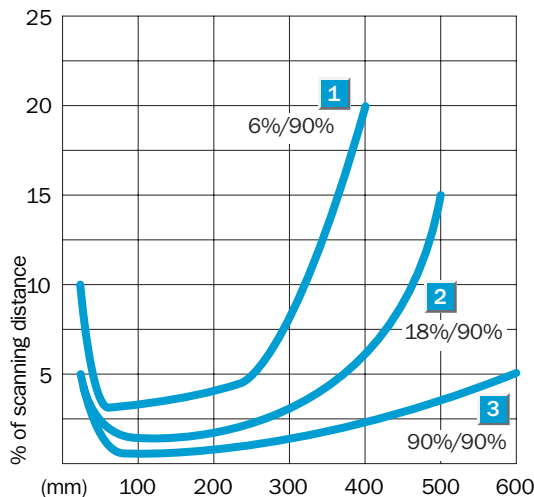

Order information	
Type	Order no.
WTB12-3N2413	1041428
WTB12-3P2413	1041423

Scanning distance
20 ... 600 mm

Photoelectric proximity sensor

- Robust metal housing with dovetail mounting clamps
- High device availability in industrial environments; in case of ambient light, optical reflections and devices mounted opposite one another
- Range between -40 °C ... +60 °C
- Parameters and diagnostics via IO Link

Dimensional drawing

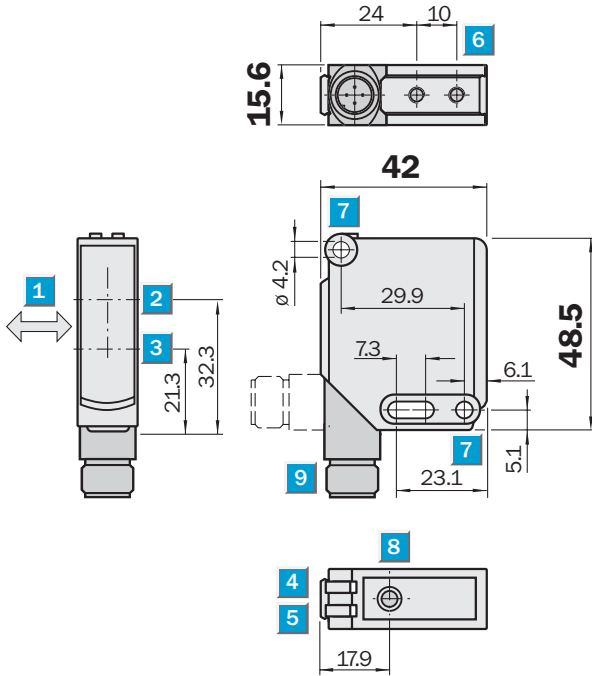

Adjustments possible

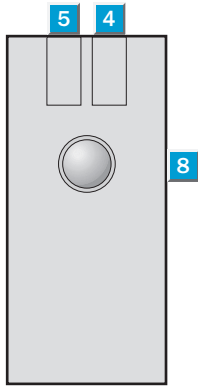

- 1 Preferred direction of the objects to be detected
- 2 Optical axis, receiver
- 3 Optical axis, sender
- 4 LED indicator green, supply voltage active
- 5 LED indicator yellow, status: light reception
- 6 Mounting thread M4 – 4 mm deep
- 7 Mounting thread, Ø 4.2 mm
- 8 Scanning distance adjuster, Teach-in: single teach button
- 9 Connection



Connection type

WTB12C-3P2413

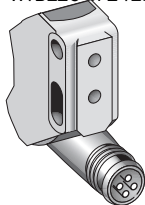

M12, 4-pin

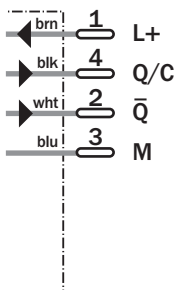

Accessories	
Connector, M12, 4-pin	
Mounting systems	

Technical data		WTB12C-3	P2413									
Scanning distance typ. max.	20 ... 600 mm ¹⁾											
Operating distance	20 ... 600 mm ¹⁾											
Adjustment of operating distance	Teach-in: single-teach button Teach-in: via IO Link											
Communication mode	COM2											
Light source, light type	LED, Infrared light, 880 nm ²⁾											
Light spot diameter	Approx. 15 x 15 mm at 200 mm distance											
Supply voltage V _s	DC 10 ... 30 V ³⁾											
Ripple	≤ 5 V _{pp} ⁴⁾											
Power consumption	≤ 30 mA ⁵⁾											
Switching outputs	PNP, Q/C PNP, not Q											
Signal voltage PNP HIGH/LOW	> V _s - 2.5 V/approx. 0 V											
Output current I _a max	100 mA											
Response time	≤ 330 μs ⁶⁾											
Switching frequency	1,500 Hz ⁷⁾											
Connection type	Connector, M12, 4-pin											
VDE protection class	□ ⁸⁾											
Circuit protection	V _s connections reverse-polarity protected/All outputs short-circuit protected/Interference suppression											
Enclosure rating	IP 66, IP 67											
Ambient temperature operation	-40 °C ... +60 °C											
Ambient temperature storage	-40 °C ... +75 °C											
Weight	Approx. 120 g											
Housing material	Zinc die-cast											

1) Object with 90 % remission (based on standard white to DIN 5033)
 2) Average service life 100,000 h at T_a = +25 °C
 3) Limit values, operation in short-circuit protected network max. 8 A
 4) May not exceed or fall short of V_s tolerances
 5) Without load
 6) Signal transit time with resistive load in switching mode. Different values possible in COM2 mode.
 7) Typ. max. value with light/dark ratio 1:1 in switching mode. Different values possible in COM2 mode.
 8) Reference voltage 50 V DC

Teach-in procedure via single-teach button

1. Position the object in the path of the beam.
2. Press teach button (for approx. 2 seconds) until the yellow LED flashes = object in focus. In the event of button activation of less than 2 seconds, the Teach command is not effective, therefore providing no protection against further unwanted manipulation.
3. Release button; yellow LED illuminates continuously = object is positively detected.

Scanning distance

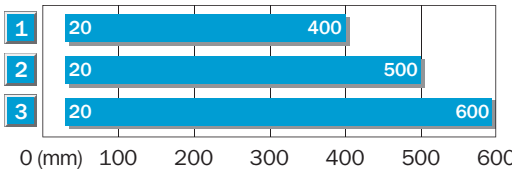

- 1 Scanning distance on black, 6 % Remission
- 2 Scanning distance on grey, 18 % Remission
- 3 Scanning on white, 90 % Remission

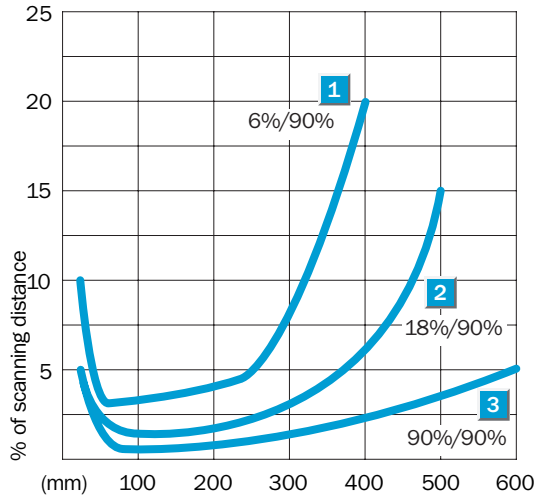

Order information	
Type	Order no.
WTB12C-3P2413	1042003



Scanning range
 0 ... 7 m
Photoelectric reflex sensor

- Robust metal housing with dovetail mounting clamps
- High device availability in industrial environments; in case of ambient light, optical reflections and devices mounted opposite one another
- Range between -40 °C ... +60 °C

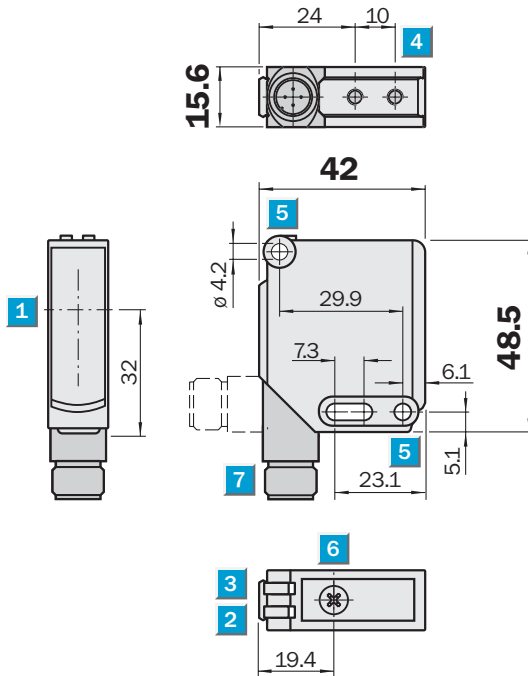
Dimensional drawing

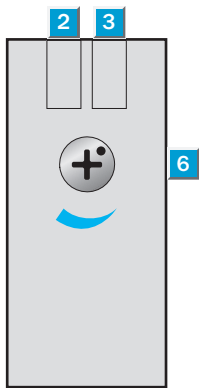

Adjustments possible



- 1 Optical axis
- 2 LED indicator yellow, status: light reception
- 3 LED indicator green, supply voltage active
- 4 Mounting thread M4 – 4 mm deep
- 5 Mounting thread, Ø 4.2 mm
- 6 Scanning range adjuster, potentiometer
- 7 Connection

Connection type

WL12-3N2431	WL12-3N1131
WL12-3P2431	WL12-3N1731
	WL12-3P1131
	WL12-3P1731

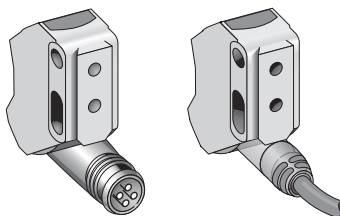

M12, 4-pin 4 x 0.25 mm²

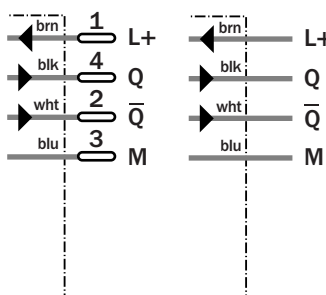

Accessories

Connector, M12, 4-pin
Mounting systems
Reflectors

Technical data		WL12-3	N1131	N1731	N2431	P1131	P1731	P2431				
Scanning range typ. max.	0 ... 7 m											
Scanning range, recommended	0 ... 5 m											
Relating to	Reflector PL80A											
Sensitivity adjustment	Potentiometer (5 turn)											
Light source, light type	LED, Red light, 640 nm ¹⁾											
Light spot diameter	Ø 100 mm at 3 m distance											
Angle of dispersion	Approx. 1.5°											
Polarisation filter	✓											
Supply voltage V_s	DC 10 ... 30 V ²⁾											
Ripple	≤ 5 V _{pp} ³⁾											
Power consumption	≤ 40 mA ⁴⁾											
	≤ 30 mA ⁴⁾											
Switching outputs	NPN antivalent											
	PNP antivalent											
Signal voltage PNP HIGH/LOW	> V _s - 2.5 V/ approx. 0 V											
Signal voltage NPN HIGH/LOW	Approx. > V _s / < 2.5 V											
Output current I _a max	100 mA											
Response time	≤ 330 µs ⁵⁾											
Switching frequency	1,500 Hz ⁶⁾											
Connection type	Cable, PVC, 2 m ⁷⁾											
	Cable, PVC, 3 m ⁷⁾											
	Connector, M12, 4-pin											
VDE protection class	□ ⁸⁾											
Circuit protection	V _s connections reverse-polarity protected/All outputs short-circuit protected/Interference suppression											
Enclosure rating	IP 66, IP 67, IP 69 K											
Ambient temperature operation	-40 °C ... +60 °C											
Ambient temperature storage	-40 °C ... +75 °C											
Weight	Approx. 200 g											
	Approx. 250 g											
	Approx. 120 g											
Housing material	Zinc die-cast ⁹⁾											

1) Average service life 100,000 h at T_a = +25 °C
 2) Limit values, operation in short-circuit protected network max. 8 A

3) May not exceed or fall short of V_s tolerances
 4) Without load

5) Signal transit time with resistive load
 6) With light/dark ratio 1:1
 7) Do not bend below 0 °C

8) Reference voltage 50 V DC
 9) Teflon-coated housing available on request

Scanning range and operating reserve

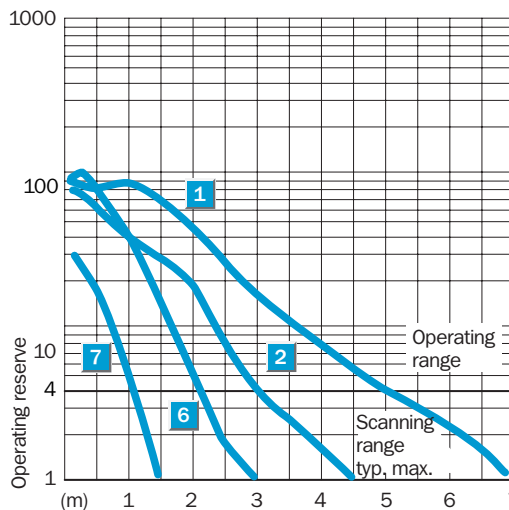
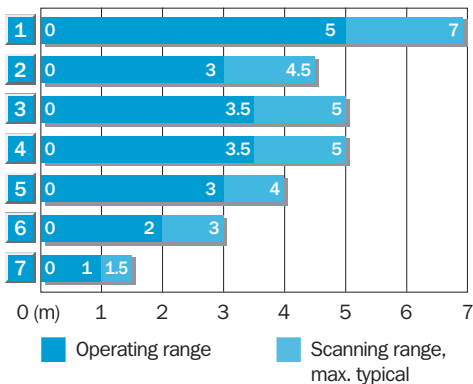

Reflector type	Operating range
1 PL80A	0 ... 5.0 m
2 C110A	0 ... 3.0 m
3 PL50A	0 ... 3.5 m
4 PL40A	0 ... 3.5 m
5 PL30A	0 ... 3.0 m
6 PL20A	0 ... 2.0 m
7 Reflective tape	0 ... 1.0 m

Order information	
Type	Order no.
WL12-3N1131	1041441
WL12-3N1731	1041442
WL12-3N2431	1041440
WL12-3P1131	1041437
WL12-3P1731	1041438
WL12-3P2431	1041436

Scanning range
0 ... 7 m

Photoelectric reflex sensor

- Robust metal housing with dovetail mounting clamps
- High device availability in industrial environments; in case of ambient light, optical reflections and devices mounted opposite one another
- Range between -40 °C ... +60 °C

Dimensional drawing

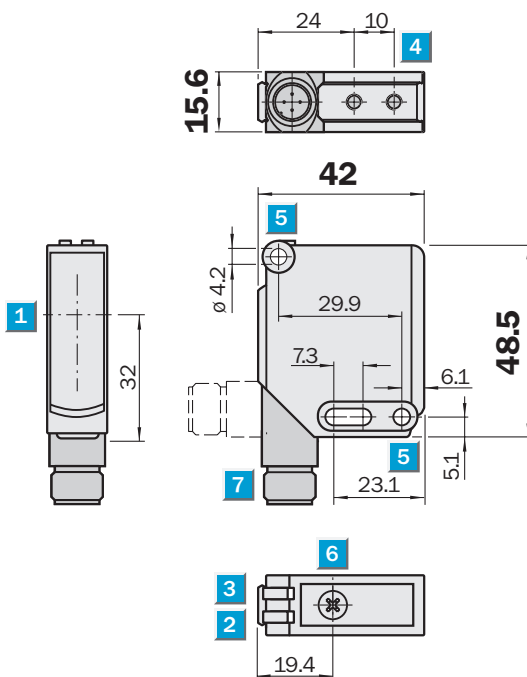

Adjustments possible

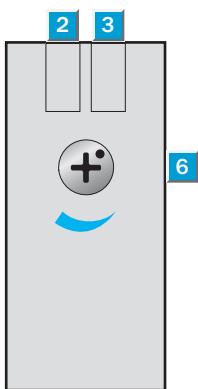

- 1 Optical axis
- 2 LED indicator yellow, status: light reception
- 3 LED indicator green, supply voltage active
- 4 Mounting thread M4 – 4 mm deep
- 5 Mounting thread, Ø 4.2 mm
- 6 Scanning range adjuster, potentiometer
- 7 Connection



Connection type

WL12-3N2441	WL12-3N1141
WL12-3P2441	WL12-3P1141

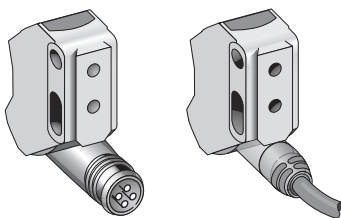

M12, 4-pin 3 x 0.25 mm²

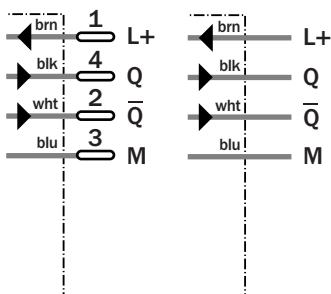

Accessories

Connector, M12, 4-pin
Mounting systems
Reflectors

Technical data		WL12-3	N1141	N2441	P1141	P2441						
Scanning range typ. max.	0 ... 7 m											
Scanning range, recommended	0 ... 5 m											
Relating to	Reflector PL80A											
Sensitivity adjustment	Potentiometer (5 turn)											
Light source, light type	LED, Red light, 640 nm ¹⁾											
Light spot diameter	Approx. 100 mm at 3 m distance											
Angle of dispersion	Approx. 1.5°											
Supply voltage V_s	DC 10 ... 30 V ²⁾											
Ripple	≤ 5 V _{pp} ³⁾											
Power consumption	≤ 40 mA ⁴⁾											
	≤ 30 mA ⁴⁾											
Switching outputs	NPN antivalent											
	PNP antivalent											
Signal voltage PNP HIGH/LOW	> V _s - 2.5 V/ approx. 0 V											
Signal voltage NPN HIGH/LOW	Approx. > V _s / < 2.5 V											
Output current I _a max	100 mA											
Response time	≤ 330 μs ⁵⁾											
Switching frequency	1,500 Hz ⁶⁾											
Connection type	Cable, PVC, 2 m ⁷⁾											
	Connector, M12, 4-pin											
VDE protection class	□ ⁸⁾											
Circuit protection	V _s connections reverse-polarity protected/All outputs short-circuit protected/Interference suppression											
Enclosure rating	IP 66, IP 67, IP 69 K											
Ambient temperature operation	-40 °C ... +60 °C											
Ambient temperature storage	-40 °C ... +75 °C											
Weight	Approx. 200 g											
	Approx. 120 g											
Housing material	Zinc die-cast ⁹⁾											

1) Average service life 100,000 h at T_a = +25 °C
 2) Limit values, operation in short-circuit protected network max. 8 A

3) May not exceed or fall short of V_s tolerances
 4) Without load

5) Signal transit time with resistive load
 6) With light/dark ratio 1:1
 7) Do not bend below 0 °C

8) Reference voltage 50 V DC
 9) Teflon-coated housing available on request

Scanning range and operating reserve

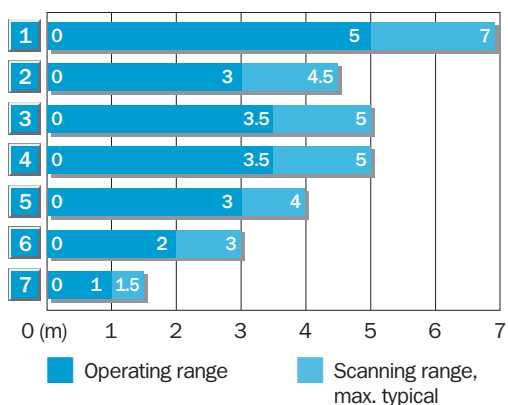

Reflector type	Operating range
1 PL80A	0 ... 5.0 m
2 C110A	0 ... 3.0 m
3 PL50A	0 ... 3.5 m
4 PL40A	0 ... 3.5 m
5 PL30A	0 ... 3.0 m
6 PL20A	0 ... 2.0 m
7 Reflective tape	0 ... 1.0 m

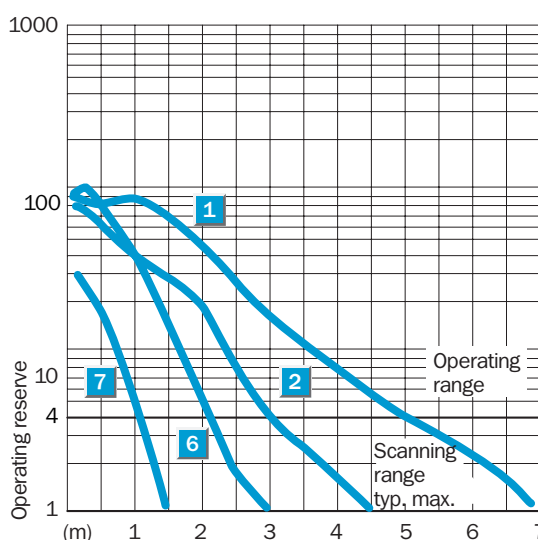

Order information	
Type	Order no.
WL12-3N1141	1041447
WL12-3N2441	1041446
WL12-3P1141	1041445
WL12-3P2441	1041444

Scanning range
0 ... 2 m

Photoelectric reflex sensor

- Robust metal housing with dovetail mounting clamps
- High device availability in industrial environments; in case of ambient light, optical reflections and devices mounted opposite one another
- Range between -40 °C ... +60 °C

Dimensional drawing

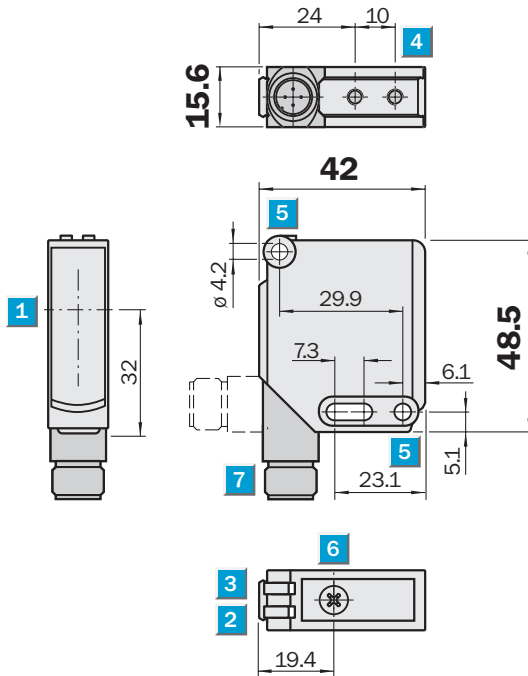

Adjustments possible

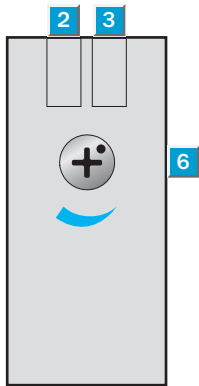

- 1 Optical axis
- 2 LED indicator yellow, status: light reception
- 3 LED indicator green, supply voltage active
- 4 Mounting thread M4 – 4 mm deep
- 5 Mounting thread, Ø 4.2 mm
- 6 Scanning range adjuster, potentiometer
- 7 Connection



Connection type

WL12-3N2451	WL12-3N1151
WL12-3P2451	WL12-3P1151

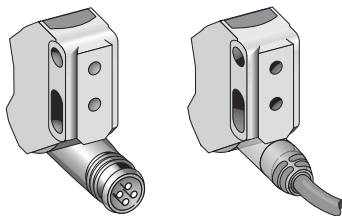

M12, 4-pin 4 x 0.25 mm²

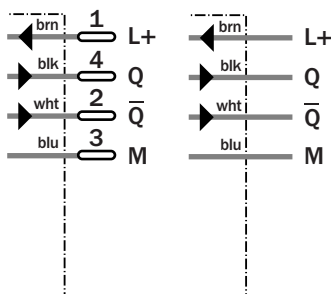

Accessories

Connector, M12, 4-pin
Mounting systems

Technical data		WL12-3	N1151	N2451	P1151	P2451						
Scanning range typ. max.	0 ... 2 m											
Scanning range, recommended	0 ... 1 m											
Relating to	Reflector PL80A											
Sensitivity adjustment	Potentiometer (5 turn)											
Light source, light type	LED, Red light, 640 nm ¹⁾											
Light spot diameter	Approx. 2 mm at 90 mm distance											
Angle of dispersion	Approx. 5°											
Polarisation filter	✓											
Supply voltage V_s	DC 10 ... 30 V ²⁾											
Ripple	≤ 5 V _{pp} ³⁾											
Power consumption	≤ 40 mA ⁴⁾											
	≤ 30 mA ⁴⁾											
Switching outputs	NPN antivalent											
	PNP antivalent											
Signal voltage PNP HIGH/LOW	> V _s - 2.5 V/approx. 0 V											
Signal voltage NPN HIGH/LOW	Approx. > V _s / _{<} 2.5 V											
Output current I _a max	100 mA											
Response time	≤ 330 μs ⁵⁾											
Switching frequency	1,500 Hz ⁶⁾											
Connection type	Cable, PVC, 2 m ⁷⁾											
	Connector, M12, 4-pin											
VDE protection class	□ ⁸⁾											
Circuit protection	V _s connections reverse-polarity protected/All outputs short-circuit protected/Interference suppression											
Enclosure rating	IP 66, IP 67, IP 69 K											
Ambient temperature operation	-40 °C ... +60 °C											
Ambient temperature storage	-40 °C ... +75 °C											
Weight	Approx. 200 g											
	Approx. 120 g											
Housing material	Zinc die-cast ⁹⁾											

1) Average service life 100,000 h at T_a = +25 °C
 2) Limit values, operation in short-circuit protected network max. 8 A
 3) May not exceed or fall short of V_s tolerances
 4) Without load
 5) Signal transit time with resistive load
 6) With light/dark ratio 1:1
 7) Do not bend below 0 °C
 8) Reference voltage 50 V DC
 9) Teflon-coated housing available on request

Scanning range and operating reserve

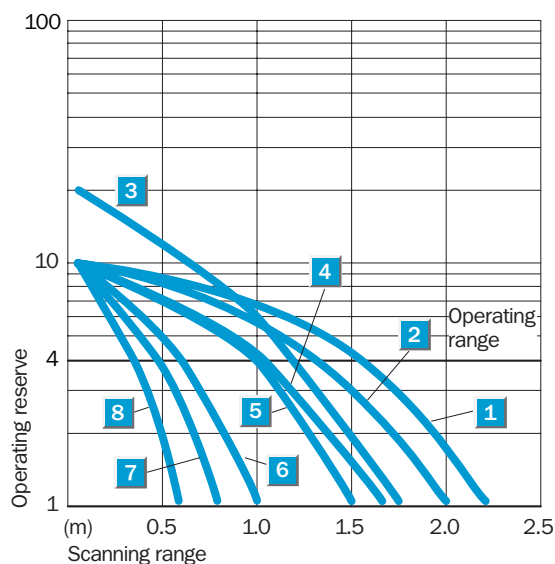
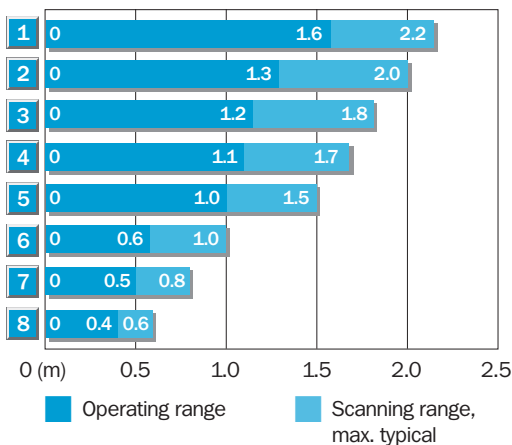

Reflector type	Operating range	
1	C110A	0 ... 1.6
2	PL80A	0 ... 1.3
3	P250F	0 ... 1.2
4	PL50A	0 ... 1.1
5	PL40A	0 ... 1.0
6	C30A	0 ... 0.6
7	P20A	0 ... 0.5
8	Reflective tape Diamond Grade	0 ... 0.4

Order information	
Type	Order no.
WL12-3N1151	1041451
WL12-3N2451	1041450
WL12-3P1151	1041449
WL12-3P2451	1041448



Scanning range
 0 ... 2 m
Photoelectric reflex sensor

- Robust metal housing with dovetail mounting clamps
- High device availability in industrial environments; in case of ambient light, optical reflections and devices mounted opposite one another
- Range between -40 °C ... +60 °C

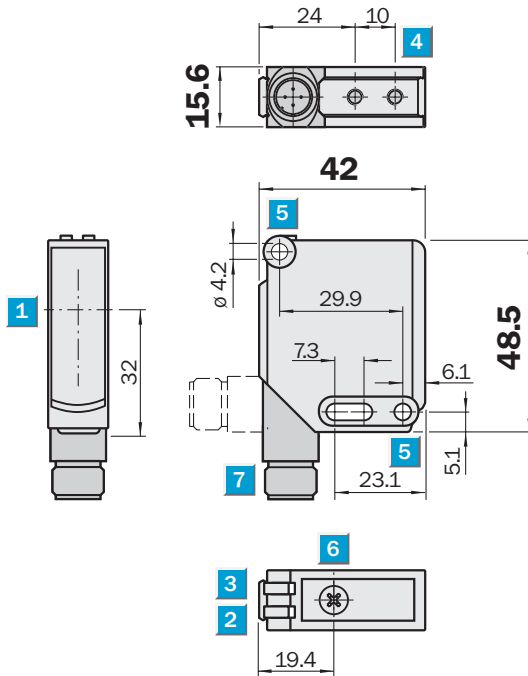
Dimensional drawing

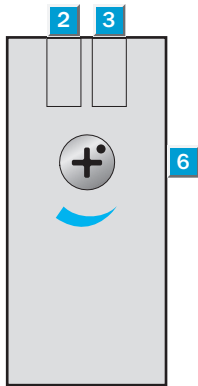

Adjustments possible



- 1 Optical axis
- 2 LED indicator yellow, status: light reception
- 3 LED indicator green, supply voltage active
- 4 Mounting thread M4 – 4 mm deep
- 5 Mounting thread, Ø 4.2 mm
- 6 Scanning range adjuster, potentiometer
- 7 Connection



Connection type

WL12-3N2461	WL12-3N1161
WL12-3P2461	WL12-3P1161

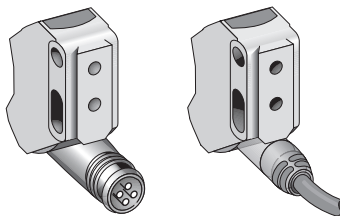

M12, 4-pin 4 x 0.25 mm²

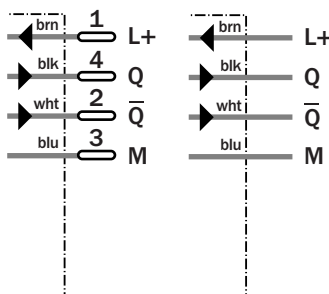

Accessories

Connector, M12, 4-pin
Mounting systems

Technical data		WL12-3	N1161	N2461	P1161	P2461						
Scanning range typ. max.	0 ... 2 m											
Scanning range, recommended	0 ... 1 m											
Relating to	Reflector PL80A											
Sensitivity adjustment	Potentiometer (5 turn)											
Light source, light type	LED, Red light, 640 nm ¹⁾											
Light spot diameter	Approx. 2 mm at 90 mm distance											
Angle of dispersion	Approx. 5°											
Supply voltage V_s	DC 10 ... 30 V ²⁾											
Ripple	≤ 5 V _{pp} ³⁾											
Power consumption	≤ 40 mA ⁴⁾											
	≤ 30 mA ⁴⁾											
Switching outputs	NPN antivalent											
	PNP antivalent											
Signal voltage PNP HIGH/LOW	> V _s - 2.5 V/approx. 0 V											
Signal voltage NPN HIGH/LOW	Approx. > V _s / $<$ 2.5 V											
Output current I _a max	100 mA											
Response time	≤ 330 μs ⁵⁾											
Switching frequency	1,500 Hz ⁶⁾											
Connection type	Cable, PVC, 2 m ⁷⁾											
	Connector, M12, 4-pin											
VDE protection class	□ ⁸⁾											
Circuit protection	V _s connections reverse-polarity protected/All outputs short-circuit protected/Interference suppression											
Enclosure rating	IP 66, IP 67, IP 69 K											
Ambient temperature operation	-40 °C ... +60 °C											
Ambient temperature storage	-40 °C ... +75 °C											
Weight	Approx. 200 g											
	Approx. 120 g											
Housing material	Zinc die-cast ⁹⁾											

1) Average service life 100,000 h at T_a = +25 °C
 2) Limit values, operation in short-circuit protected network max. 8 A
 3) May not exceed or fall short of V_s tolerances
 4) Without load
 5) Signal transit time with resistive load
 6) With light/dark ratio 1:1
 7) Do not bend below 0 °C
 8) Reference voltage 50 V DC
 9) Teflon-coated housing available on request

Scanning range and operating reserve

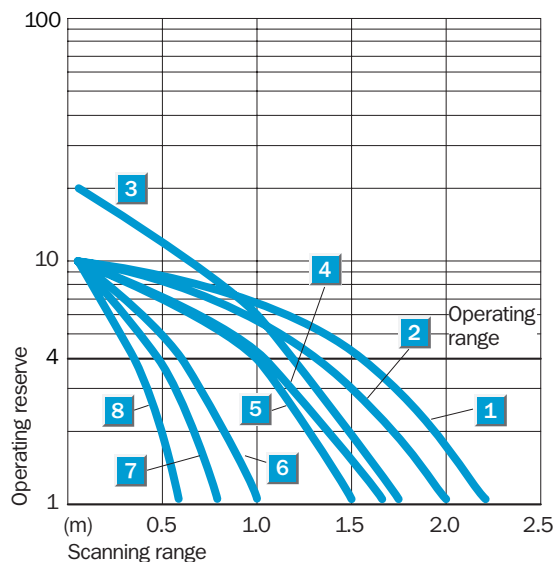
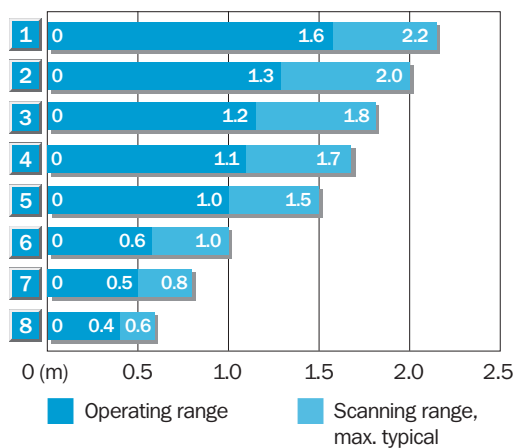

	Reflector type	Operating range
1	C110A	0 ... 1.6
2	PL80A	0 ... 1.3
3	P250F	0 ... 1.2
4	PL50A	0 ... 1.1
5	PL40A	0 ... 1.0
6	C30A	0 ... 0.6
7	P20A	0 ... 0.5
8	Reflective tape Diamond Grade	0 ... 0.4

Order information	
Type	Order no.
WL12-3N1161	1041455
WL12-3N2461	1041454
WL12-3P1161	1041453
WL12-3P2461	1041452

Photoelectric reflex sensor, WL12G-3, for transparent objects, red light

Scanning range
0 ... 4 m

Photoelectric reflex sensor

- Robust metal housing with dovetail mounting clamps
- Reliable detection of glass and transparent films
- Adjustable sensitivity
- High device availability in industrial environments
- Range between -40 °C ... +60 °C

Dimensional drawing

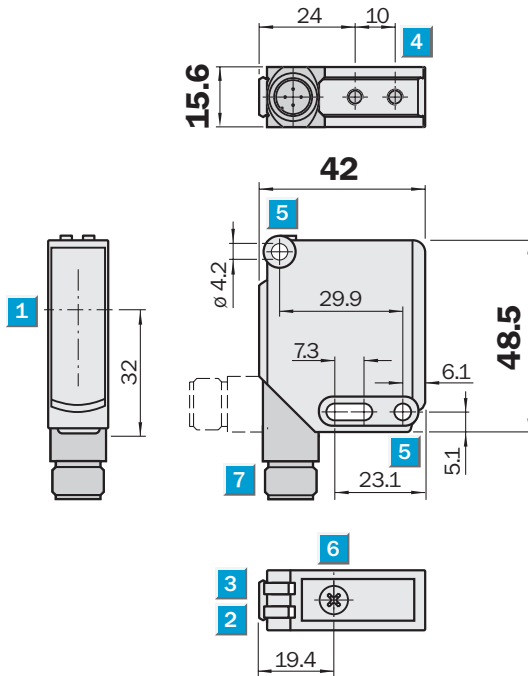

Adjustments possible

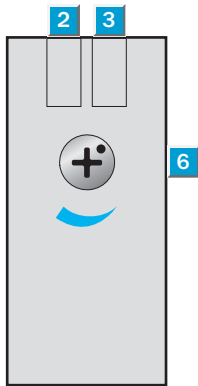

- 1 Optical axis
- 2 LED indicator yellow, status: light reception
- 3 LED indicator green, supply voltage active
- 4 Mounting thread M4 – 4 mm deep
- 5 Mounting thread, Ø 4.2 mm
- 6 Scanning range adjuster, potentiometer
- 7 Connection



Connection type

WL12G-302431 | WL12G-3B2581

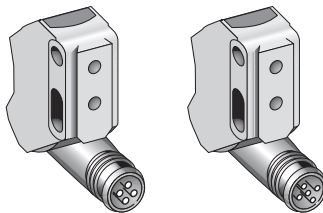

M12, 4-pin

M12, 5-pin

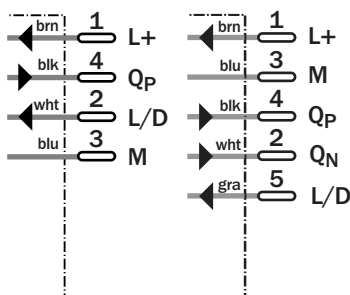

Accessories

- Connector, M12, 4-pin
- Connector, M12, 5-pin
- Mounting systems

Technical data		WL12G-3	B2531	02431										
Scanning range max.	0 ... 4 m													
Relating to	Reflector PL80A													
Sensitivity adjustment	Potentiometer (11 turn)													
Light source, light type	LED, Red light, 640 nm ¹⁾													
Light spot diameter	Approx. 25 mm at 1.5 m distance													
Angle of dispersion	Approx. 1.5°													
Polarisation filter	✓													
Supply voltage V_s	DC 10 ... 30 V ²⁾													
Ripple	≤ 5 V _{pp} ³⁾													
Power consumption	≤ 30 mA ⁴⁾													
Switching outputs	Q _{PNP} and Q _{NPN}													
	PNP													
Signal voltage PNP HIGH/LOW	> V _s - 3 V / approx. 0 V													
Signal voltage NPN HIGH/LOW	Approx. > V _s / < 3 V													
Switching mode	Light-/dark-switching, switchable ⁵⁾													
Output current I _a max	100 mA													
Response time	≤ 330 μs ⁶⁾													
Switching frequency	1,500 Hz ⁷⁾													
Connection type	Connector, M12, 5-pin													
	Connector, M12, 4-pin													
VDE protection class	□ ⁸⁾													
Circuit protection	V _s connections reverse-polarity protected / All outputs short-circuit protected / Interference suppression													
Enclosure rating	IP 66, IP 67, IP 69 K													
Ambient temperature operation	-40 °C ... +60 °C													
Ambient temperature storage	-40 °C ... +75 °C													
Weight	Approx. 120 g													
Housing material	Zinc die-cast ⁹⁾													

1) Average service life 100,000 h at T_a = +25 °C
 2) Limit values, operation in short-circuit protected network max. 8 A

3) May not exceed or fall short of V_s tolerances
 4) Without load

5) Control cable 0 V or open-circuited = light-switching. Control cable V_s = dark-switching
 6) Signal transit time with resistive load

7) With light/dark ratio 1:1
 8) Reference voltage 50 V DC
 9) Teflon-coated housing available on request

Scanning range

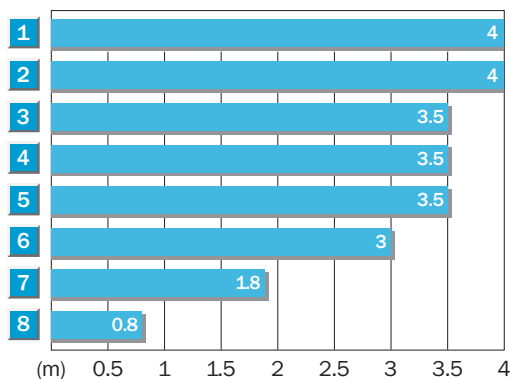

■ Scanning range max.

Reflektor type	scanning range max.	
1	PL80A	0 ... 4.0 m
2	C110A	0 ... 4.0 m
3	P250F	0 ... 3.5 m
4	PL50A	0 ... 3.5 m
5	PL40A	0 ... 3.5 m
6	PL30A	0 ... 3.0 m
7	PL20A	0 ... 1.8 m
8	Reflective tape Diamond Grade	0 ... 0.8 m

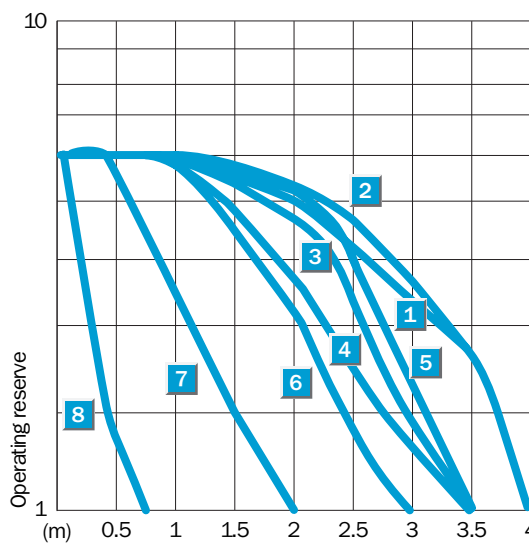

Order information

Type	Order no.
WL12G-3B2531	1041456
WL12G-302431	1041457

Through-beam photoelectric sensor, WSE12-3, red light

Scanning range
0 ... 20 m

Through-beam photoelectric sensor

- Robust metal housing with dovetail mounting clamps
- High device availability in industrial environments; in case of ambient light, optical reflections and devices mounted opposite one another
- Range between -40 °C ... +60 °C

Dimensional drawing

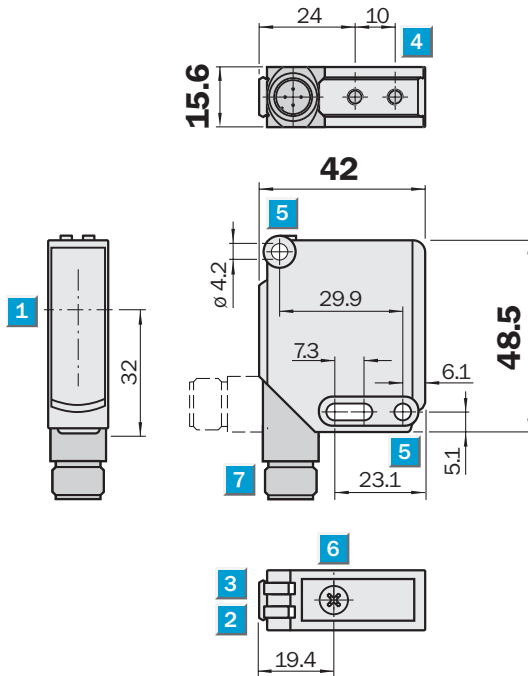

Adjustments possible

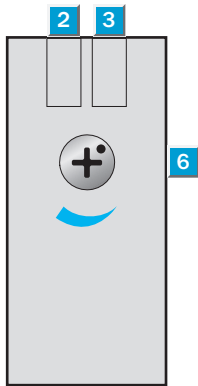

- 1 Optical axis
- 2 LED indicator yellow, status: light reception (WE)
- 3 LED indicator green, supply voltage active (WS and WE)
- 4 Mounting thread M4 – 4 mm deep
- 5 Mounting thread, Ø 4.2 mm
- 6 Scanning range adjuster, potentiometer
- 7 Connection

Connection type

WSE12-3N2431
WSE12-3P2431

WSE12-3N1131
WSE12-3P1131

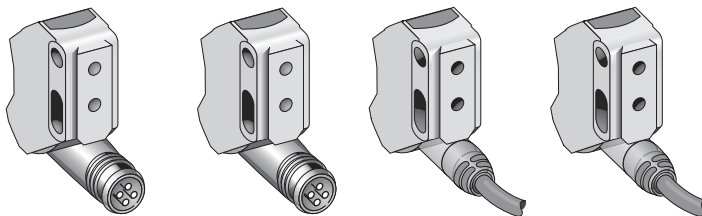

M12, 4-pin
Sender

M12, 4-pin
Receiver

4 x 0.25 mm²
Sender

4 x 0.25 mm²
Receiver

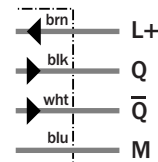
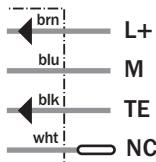
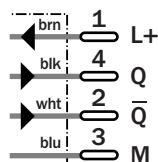
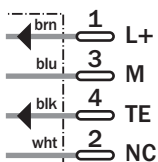

Accessories

Connector, M12, 4-pin
Mounting systems

Technical data		WSE12-3	N1131	N2431	P1131	P2431							
Scanning range typ. max.	0 ... 20 m												
Scanning range, recommended	0 ... 15 m												
Sensitivity adjustment	Potentiometer (5 turn)												
Light source, light type	LED, Red light, 640 nm ¹⁾												
Light spot diameter	Approx. 220 mm at 15 m distance												
Angle of dispersion	Approx. 1.5°												
Supply voltage V _s	DC 10 ... 30 V ²⁾												
Ripple	≤ 5 V _{pp} ³⁾												
Power consumption, sender	≤ 30 mA ⁴⁾												
Power consumption, receiver	≤ 25 mA ⁴⁾												
	≤ 15 mA ⁴⁾												
Switching outputs	NPN antivalent												
	PNP antivalent												
Signal voltage PNP HIGH/LOW	> V _s - 2.5 V/ approx. 0 V												
Signal voltage NPN HIGH/LOW	Approx. > V _s / < 2.5 V												
Output current I _a max	100 mA												
Response time	≤ 330 μs ⁵⁾												
Switching frequency	1,500 Hz ⁶⁾												
Test input sender off	TE to 0 V												
Connection type	Cable, PVC, 2 m ⁷⁾												
	Connector, M12, 4-pin												
VDE protection class	□ ⁸⁾												
Circuit protection	V _s connections reverse-polarity protected/All outputs short-circuit protected/Interference suppression												
Enclosure rating	IP 66, IP 67, IP 69 K												
Ambient temperature operation	-40 °C ... +60 °C												
Ambient temperature storage	-40 °C ... +75 °C												
Weight	Approx. 200 g												
	Approx. 120 g												
Housing material	Zinc die-cast ⁹⁾												

1) Average service life 100,000 h at T_a = +25 °C
 2) Limit values, operation in short-circuit protected network max. 8 A

3) May not exceed or fall short of V_s tolerances
 4) Without load

5) Signal transit time with resistive load
 6) With light/dark ratio 1:1
 7) Do not bend below 0 °C

8) Reference voltage 50 V DC
 9) Teflon-coated housing available on request

Scanning range and operating reserve

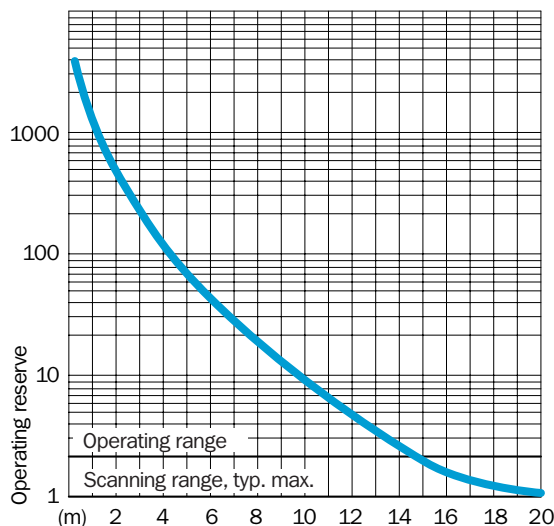
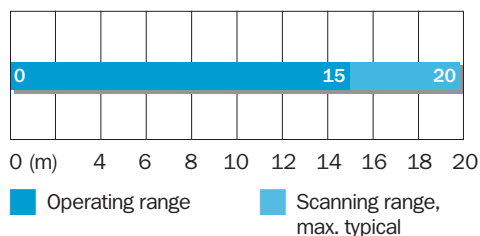

Order information	
Type	Order no.
WSE12-3N1131	1041463
WSE12-3N2431	1041462
WSE12-3P1131	1041460
WSE12-3P2431	1041459

Dimensional drawings and order information

SENSICK screw-in system M12, 4- or 5-pin, enclosure rating IP 67

Female connector M12, 4- or 5-pin, straight

Type	Order no.	Contacts
DOS-1204-G	6007302	4
DOS-1205-G	6009719	5

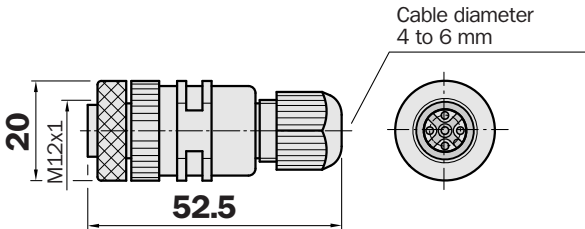

Female connector M12, 4- or 5-pin, right angle

Type	Order no.	Contacts
DOS-1204-W	6007303	4
DOS-1205-W	6009720	5

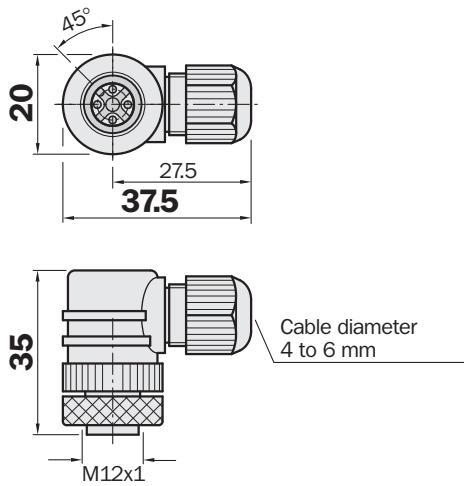

Female connector M12, 4- or 5-pin, straight

Cable diameter 5/6 mm, 4/5 x 0.25 mm², sheath PVC

Type	Order no.	Contacts	Cable length
DOL-1204-G02M	6009382	4	2 m
DOL-1204-G05M	6009866	4	5 m
DOL-1204-G10M	6010543	4	10 m
DOL-1204-G15M	6010753	4	15 m
DOL-1205-G02M	6008899	5	2 m
DOL-1205-G05M	6009868	5	5 m
DOL-1205-G10M	6010544	5	10 m

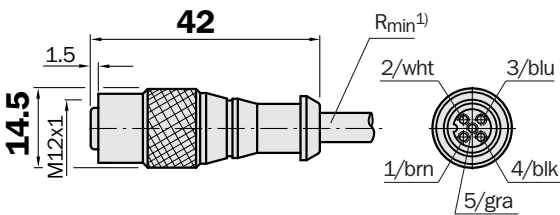

Female connector M12, 4- or 6-pin, right angle

Cable diameter 5/6 mm, 4/5 x 0.25 mm², sheath PVC

Type	Order no.	Contacts	Cable length
DOL-1204-W02M	6009383	4	2 m
DOL-1204-W05M	6009867	4	5 m
DOL-1204-W10M	6010541	4	10 m
DOL-1205-W02M	6008900	5	2 m
DOL-1205-W05M	6009869	5	5 m
DOL-1205-W10M	6010542	5	10 m

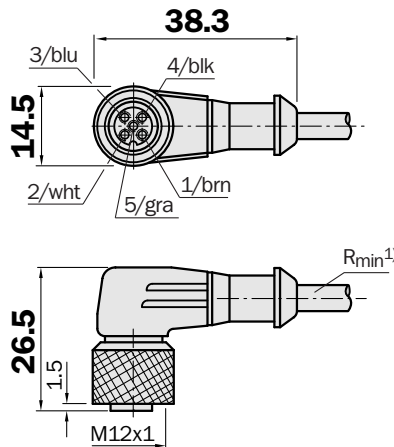

¹⁾ Minimum bend radius in dynamic use
R_{min} = 20 x cable diameter

Dimensional drawings and order information

SENSICK screw-in system M12, 4- or 5-pin, enclosure rating IP 67

Male connector M12, 4- or 5-pin, straight

Type	Order no.	Contacts
STE-1204-G	6009932	4
STE-1205-G	6022083	5

Male connector M12, 4- or 5-pin, right angle

Type	Order no.	Contacts
STE-1204-W	6022084	4
STE-1205-W	6022082	5

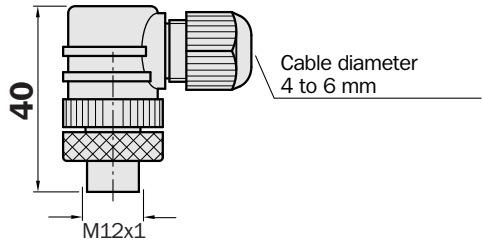
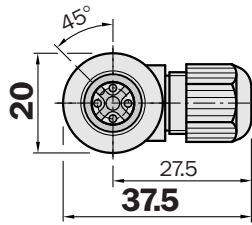
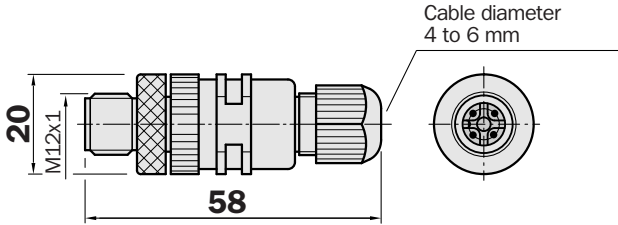

Dimensional drawings and order information

Connectors

Round connectors connecting cables "Food & Beverage", gold plated pins, enclosure rating IP 69K, improved resistance to chemicals, acids and cleaning agent, stainless steel locking nut

DOL-12...

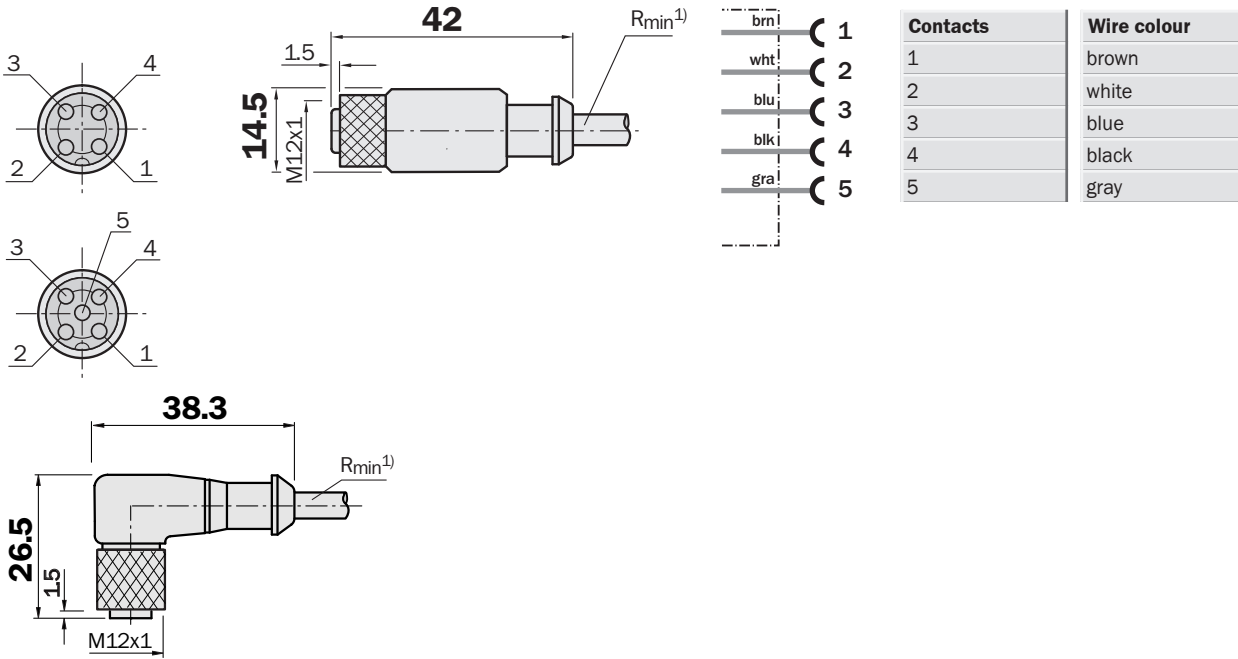

1) Minimum bend radius in dynamic use
 $R_{min} = 20 \times \text{cable diameter}$

Round connectors M12, connecting cable "Food & Beverage"

Type	Order no.	Description	Contacts	Cable length [m]
DOL-1204-G02MN	6028128	Female connector straight	4	2
DOL-1204-G05MN	6028130	Female connector straight	4	5
DOL-1204-G10MN	6028132	Female connector straight	4	10
DOL-1204-G25MN	6028134	Female connector straight	4	25
DOL-1204-W02MN	6028129	Female connector angled	4	2
DOL-1204-W05MN	6028131	Female connector angled	4	5
DOL-1204-W10MN	6028133	Female connector angled	4	10
DOL-1204-W25MN	6028135	Female connector angled	4	25
DOL-1205-G02MN	6028140	Female connector straight	5	2
DOL-1205-G05MN	6028141	Female connector straight	5	5
DOL-1205-G10MN	6028142	Female connector straight	5	10
DOL-1205-G25MN	6028143	Female connector straight	5	25

Dimensional drawings and order information

Mounting systems

Clamp

Type	Order no.	Countersunk screw M4 x 15 mm included with delivery
BEF-KH-W12	2013285	

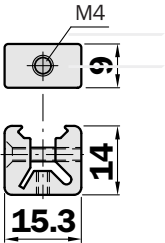

Double clamp

Type	Order no.	2 countersunk screws M4 x 15 mm
BEF-DKH-W12	2013947	

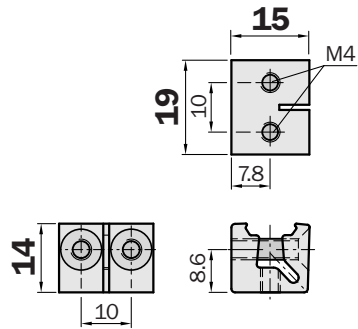

Mounting bracket, small (stainless steel)

Type	Order no.
BEF-WK-W12	2012938

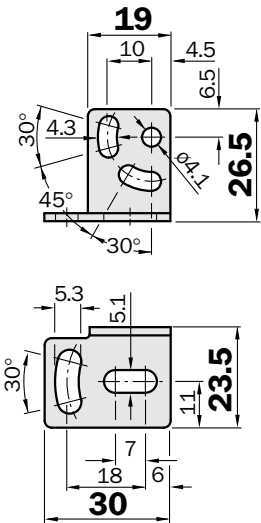

Mounting bracket, large (stainless steel)

Type	Order no.
BEF-WG-W12	2013942

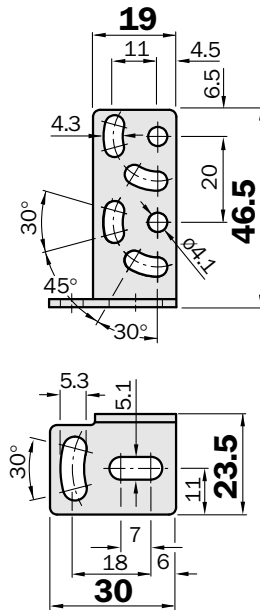

Dimensional drawings and order information

Mounting systems

Universal bar clamps for sensors and reflectors

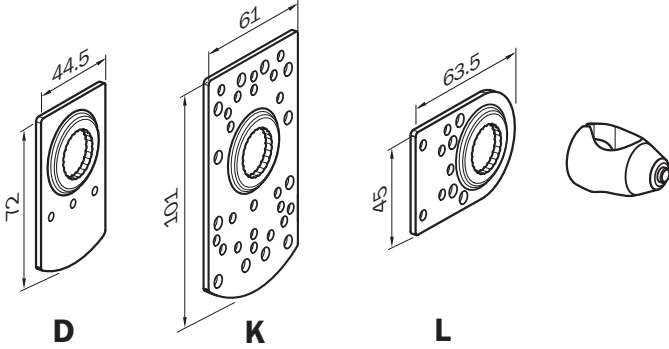

Distance Z	
Bar centre - inner plate surface	
Bar- ϕ in mm	Distance Z in mm
12	15.0
14	16.4
15	17.1
18	19.2
20	20.7

Mounting plates	Type	Order no.	for device/reflector type
D	BEF-KHS-D01	2022461	W11, W12-2
K	BEF-KHS-K01	2022718	
L	BEF-KHS-KH1	2022726	Clamp without mounting plate

Dimensional drawings and order information

Reflectors, plastic design for temperatures up to 65 °C

Reflector 20 x 40 mm, screwable

Type	Order no.
PL20A	1012719

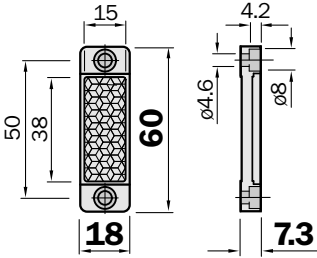

Reflector 30 x 50 mm, screwable

Type	Order no.
PL30A	1002314

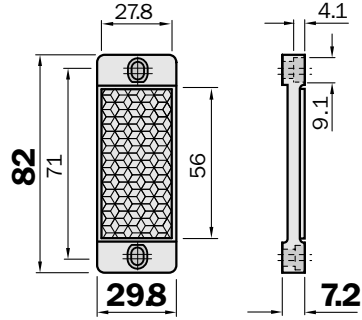

Reflector 40 x 60 mm, screwable

Type	Order no.
PL40A	1012720

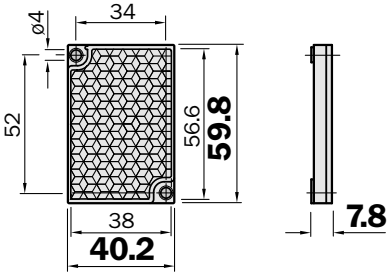

Reflector 6-sided, width across flats 52 mm, screwable

Type	Order no.
PL50A	1000132

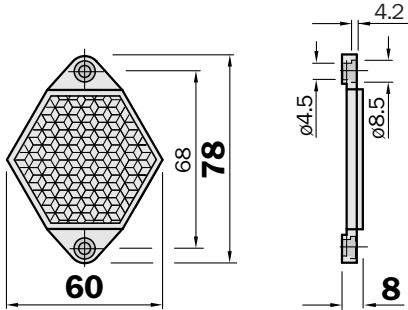

Dimensional drawings and order information

Reflectors, plastic design for temperatures up to 65 °C

Reflector 80 x 80 mm, screwable

Type	Order no.
PL80A	1003865

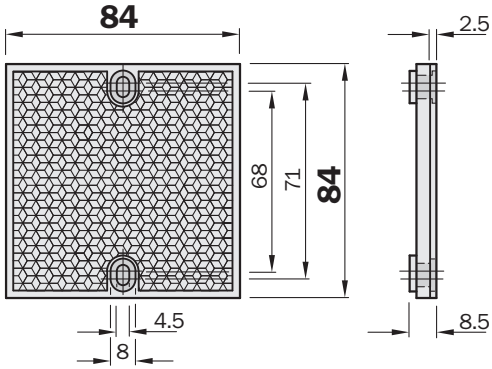

Reflector Ø 84 mm, screwable

Type	Order no.
C110A	5304549

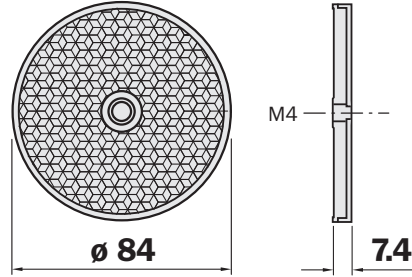

Reflectors, plastic design for temperatures up to 110 °C

Reflector 47 x 47 mm, screwable

Type	Order no.
P250H	5315124

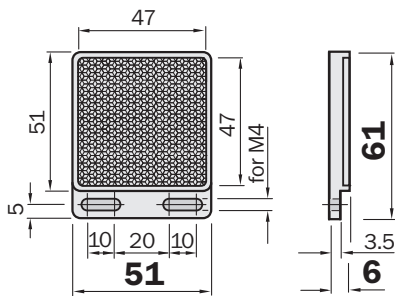

Micro triple reflector 47 x 47 mm, screwable

Type	Order no.
P250F	5308843

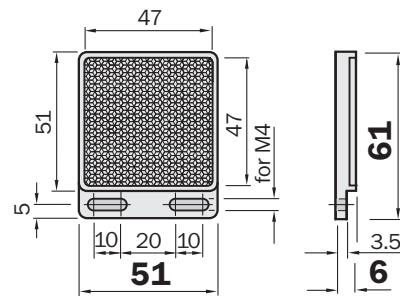

Dimensional drawings and order information

Self-adhesive reflective tape for photoelectric switches with polarising filter

Reflective tape "Diamond Grade"

Cut to size	
Type	Order no.
REF-DG-K	4019634

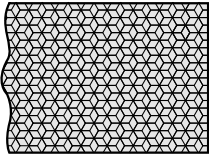

Reflective tape, self-adhesive, length of roll 22.8 m

Type	Order no.	Width
REF-PLUS-R25	5319929	25 mm
REF-PLUS-R50	5319981	50 mm

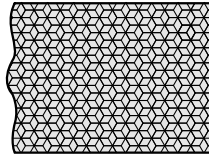

Reflective tape, self-adhesive, cut to size

Type	Order no.	Width
REF-PLUS-R25-K	4051184	25 mm
REF-PLUS-R50-K	4051185	50 mm

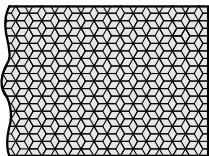

Masks

Mask card for WS/WE12-3

with 2 self-adhesive masks each for sender (WS) and receiver (WE)

Slot width X: 0.5 mm/1.0 mm/1.5 mm/2.0 mm

Type	Order no.
BL12-SKN	4031815

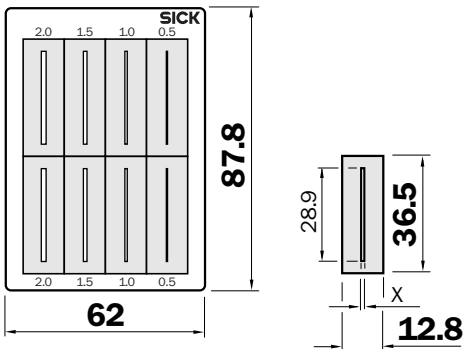

Australia

Phone +61 3 9497 4100
1800 33 48 02 – tollfree
E-Mail sales@sick.com.au

Belgium/Luxembourg

Phone +32 (0)2 466 55 66
E-Mail info@sick.be

Brasil

Phone +55 11 3215-4900
E-Mail sac@sick.com.br

Ceská Republika

Phone +420 2 57 91 18 50
E-Mail sick@sick.cz

China

Phone +852-2763 6966
E-Mail ghk@sick.com.hk

Danmark

Phone +45 45 82 64 00
E-Mail sick@sick.dk

Deutschland

Phone +49 211 5301-301
E-Mail kundenservice@sick.de

España

Phone +34 93 480 31 00
E-Mail info@sick.es

France

Phone +33 1 64 62 35 00
E-Mail info@sick.fr

Great Britain

Phone +44 (0)1727 831121
E-Mail info@sick.co.uk

India

Phone +91-22-4033 8333
E-Mail info@sick-india.com

Israel

Phone +972-4-999-0590
E-Mail info@sick-sensors.com

Italia

Phone +39 02 27 43 41
E-Mail info@sick.it

Japan

Phone +81 (0)3 3358 1341
E-Mail support@sick.jp

Nederlands

Phone +31 (0)30 229 25 44
E-Mail info@sick.nl

Norge

Phone +47 67 81 50 00
E-Mail austefjord@sick.no

Österreich

Phone +43 (0)22 36 62 28 8-0
E-Mail office@sick.at

Polska

Phone +48 22 837 40 50
E-Mail info@sick.pl

Republic of Korea

Phone +82-2 786 6321/4
E-Mail info@sickkorea.net

Republika Slovenija

Phone +386 (0)1-47 69 990
E-Mail office@sick.si

România

Phone +40 356 171 120
E-Mail office@sick.ro

Russia

Phone +7 495 775 05 34
E-Mail info@sick-automation.ru

Schweiz

Phone +41 41 619 29 39
E-Mail contact@sick.ch

Singapore

Phone +65 6744 3732
E-Mail admin@sicksgp.com.sg

Suomi

Phone +358-9-25 15 800
E-Mail sick@sick.fi

Sverige

Phone +46 10 110 10 00
E-Mail info@sick.se

Taiwan

Phone +886 2 2375-6288
E-Mail sales@sick.com.tw

Türkiye

Phone +90 216 587 74 00
E-Mail info@sick.com.tr

United Arab Emirates

Phone +971 4 8865 878
E-Mail info@sick.ae

USA/Canada/México

Phone +1(952) 941-6780
1 800-325-7425 – tollfree
E-Mail info@sickusa.com

More representatives and agencies
in all major industrial nations at
www.sick.com