

C-HVSL1000063X

REV	ECN	DESCRIPTION	DATE	MODIFIED
1		PRE-RELEASE	20/08/13	Eric
2		ADD WIRE DIAMETER	15/09/15	Robin Yuan

SCALE 1:2

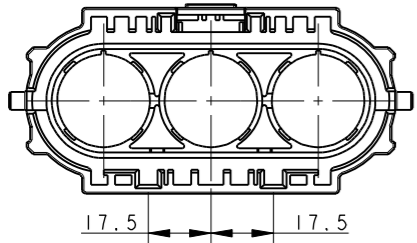

HVSL 1000 06 3 A
A CODING

CUSTOMER DRAWING

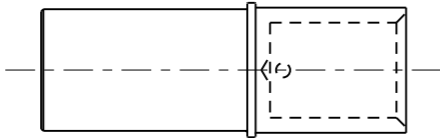
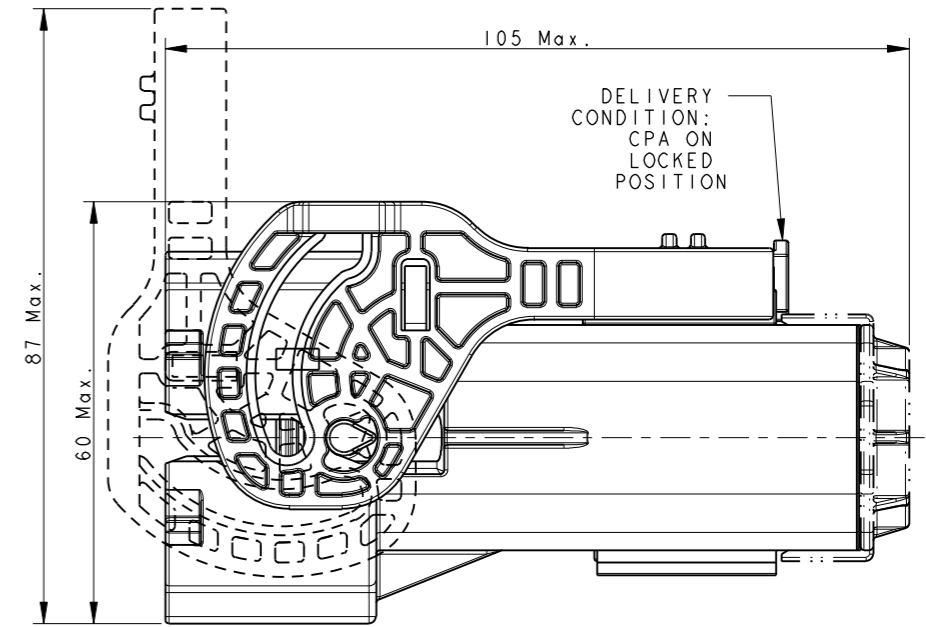
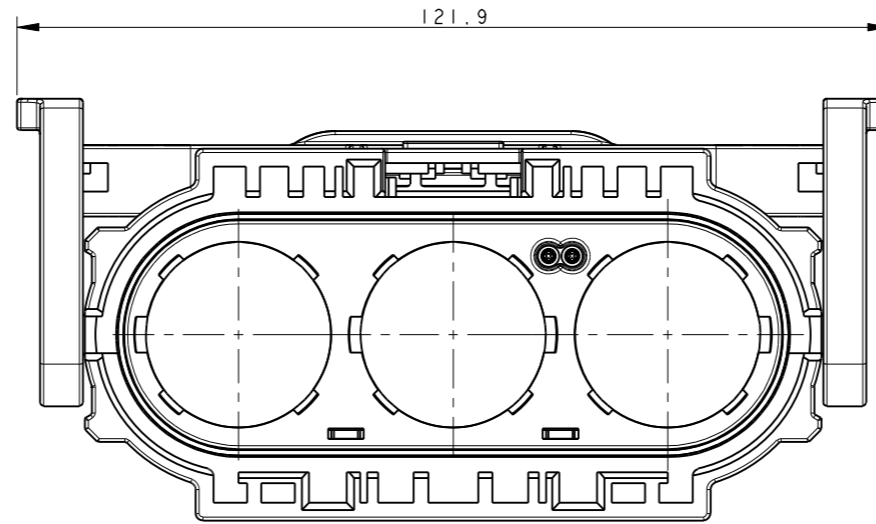

SOCKET CONTACT

- P/N: C4200036161 --70 mm² WIRE
- C4200036162 --50 mm² WIRE
- C4200036163 --35 mm² WIRE
- C4200036164 --25 mm² WIRE

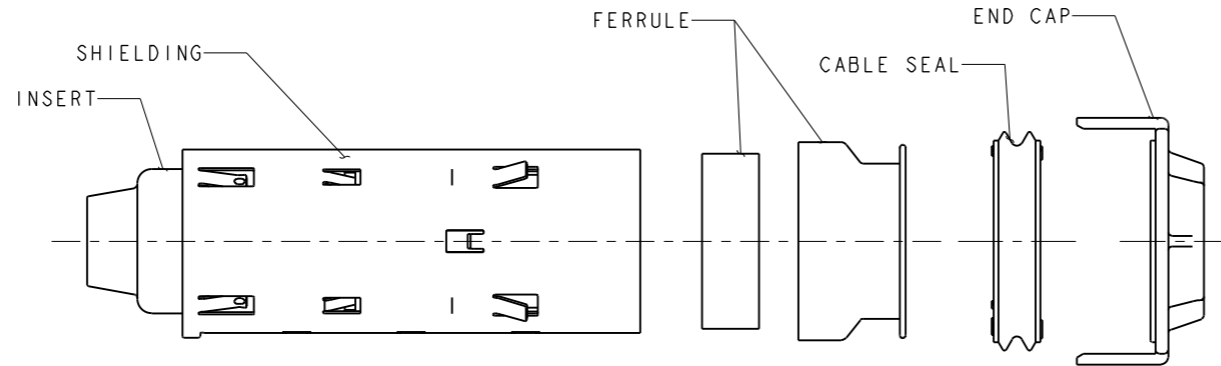

KIT OF SOCKET INSERT

- P/N: C4220036011 --70 mm² WIRE OD=19.0 ± 0.7MM
- C4220036012 --50 mm² WIRE OD=16.5 ± 0.4MM
- C4220036013 --35 mm² WIRE OD=14.2 ± 0.4MM
- C4220036014 --25 mm² WIRE OD=11.9 ± 0.3MM

NOTES:

1. MATERIAL & FINISH:
 PLASTIC BODY: THERMOPLASTICS UL 94V-0 ORANGE COLOR
 SOCKET CONTACT: COPPER ALLOY SILVER PLATED
 SHIELDING: COPPER ALLOY TIN PLATED
 FERRULE: STAINLESS STEEL
 CABLE SEAL: SILICONE RUBBER
2. ELECTRICAL CHARACTERISTICS:
 HIGH VOLTAGE RATED 1000 V DC MAX.
 CURRENT RATED 250 A MAX.
 WITHSTANDING VOLTAGE 3000 V AC
 PRODUCTS ARE COMPLIANCE WITH EN 60664-1 POLLUTION II
3. ENVIROMENT CHARACTERISTICS:
 IP67 IP6K9K RATED (WHEN MATING)
 IP2XB RATED FOR FINGER TOUCH-PROOF
4. DELIVERY WITHOUT CONTACTS. THE CONTACTS SHOULD BE ORDERED SEPARATELY.
5. SEE APCD-TD-073 FOR ASSEMBLY INSTRUCTION.

C-HVSL1000063X

C-HVSL1000063X

DIMENSIONS ANSI Y14.5M UNITS: MM Pro/E FILE	TOLERANCES .X ±0.3 .XX ±0.10 ANGLES ±0.5°	PROJECTION 	TITLE Amphenol Pcd Shenzhen ENGR Robin Yuan 15/09/15		
			HVSL 1000 06 3 X STRAIGHT PLUG ASSEMBLY		
ORIGINAL NOT FOR CUSTOMER DISTRIBUTION	THIS DOCUMENT CONTAINS PROPRIETARY INFORMATION WHICH IS THE CONFIDENTIAL PROPERTY OF AMPHENOL PCD SHENZHEN		SIZE A3	DWG NO. C-HVSL1000063X	REV 2
			CODE: 58982	SCALE: 1:1	SHEET 1 OF 2

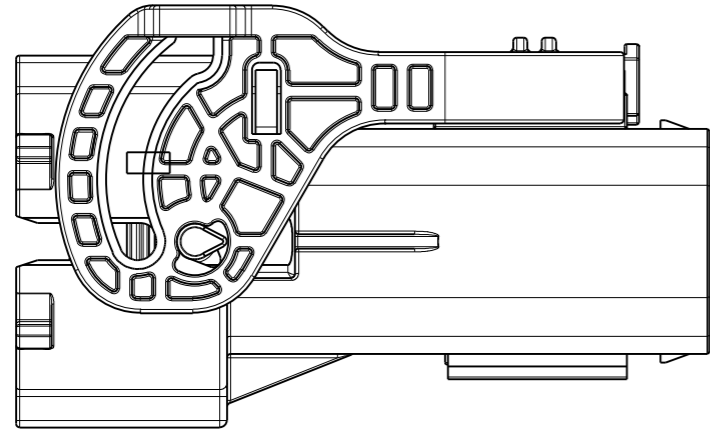

HVSL 1000 06 3 X

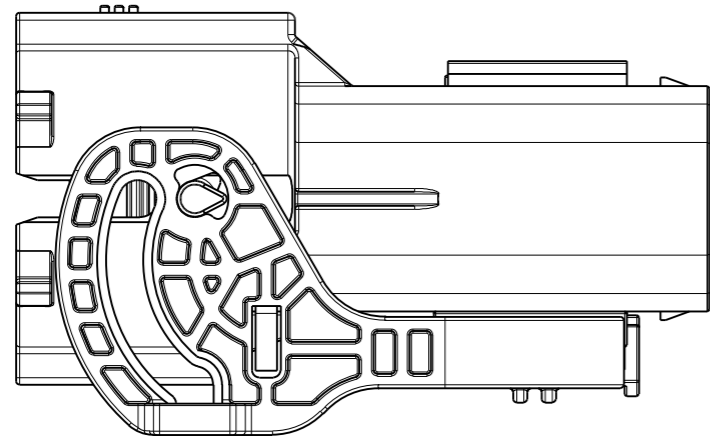

*HVSL 1000 06 3 X RL
(REVERSE LEVER)*

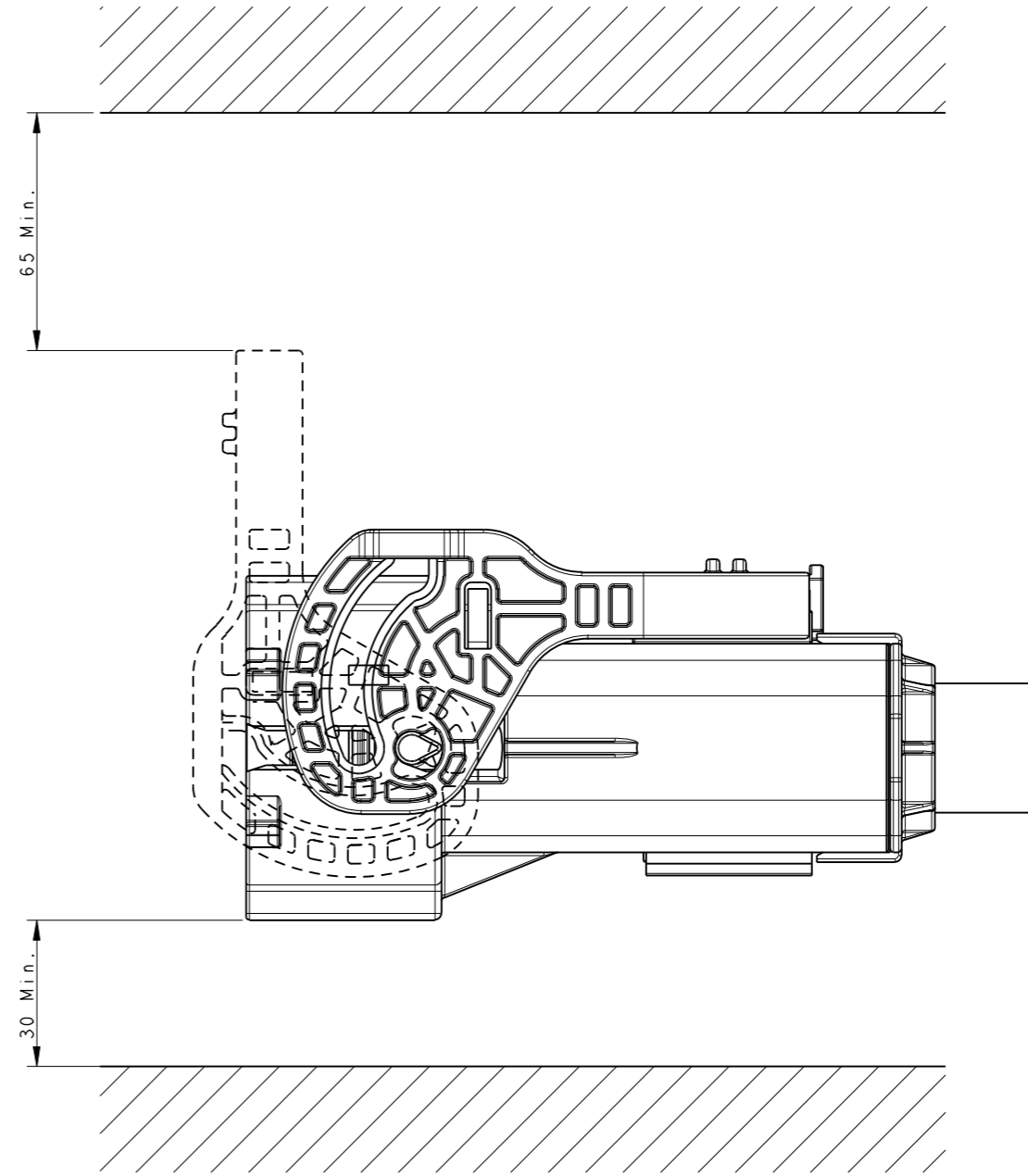

INSTALLATION CLEARANCE
ACC. TO USCAR 25

C-HVSL1000063X

C-HVSL1000063X

SIZE	DWG NO.	REV
A3	C-HVSL1000063X	2
CODE: 58982	SCALE: 0:1	SHEET 2 OF 2