

SM4100

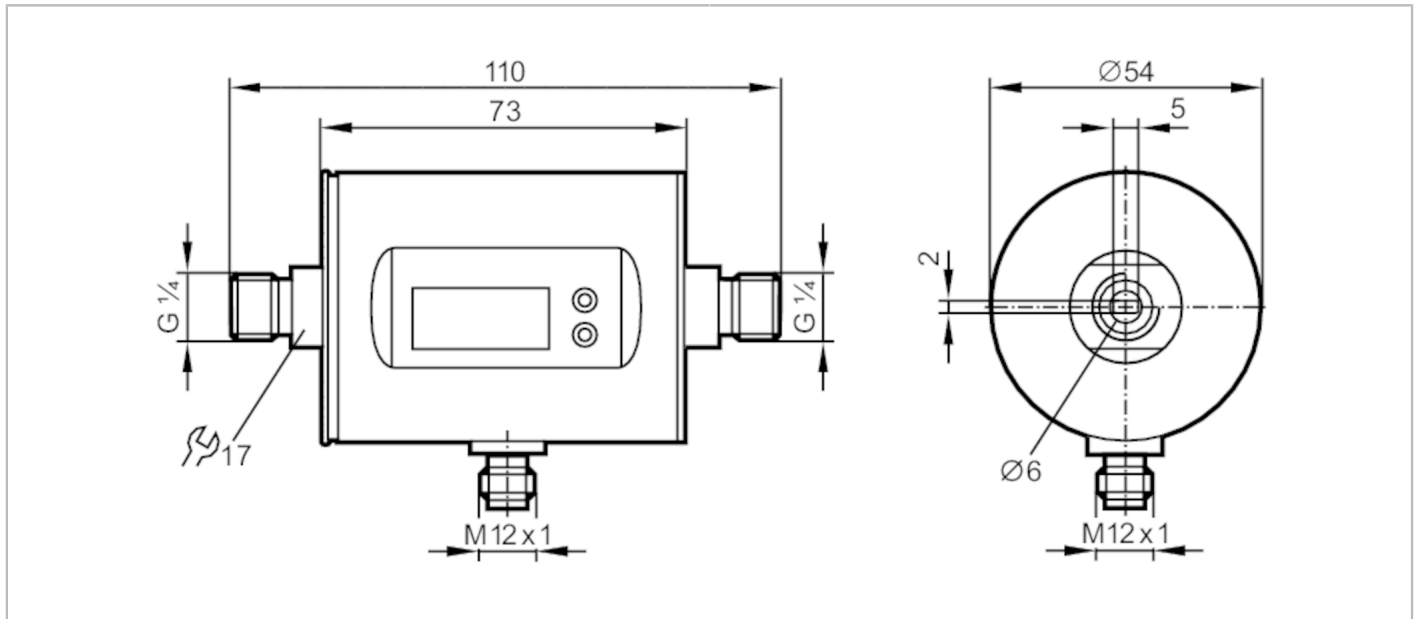

Magnetic-inductive flow meter

SMR14DXXFRKG/US-100



Product characteristics	
Number of inputs and outputs	Number of digital outputs: 2; Number of analogue outputs: 1
Process connection	threaded connection G 1/4 DN6 flat seal
Temperature monitoring	
Measuring range	[°C] -20...80
Application	
Special feature	Gold-plated contacts
Application	totaliser function; for industrial applications
Installation	connection to pipe by means of an adapter
Media	conductive liquids; water; hydrous media
Note on media	conductivity: $\geq 20 \mu\text{S/cm}$ viscosity: $< 70 \text{ mm}^2/\text{s}$ (40 °C)
Medium temperature	[°C] 0...60
Pressure rating	[bar] 10
MAWP (for applications according to CRN)	[bar] 5.5
Electrical data	
Operating voltage	[V] 18...30 DC; (according to EN 50178 SELV/PELV)
Current consumption	[mA] < 80
Protection class	III
Reverse polarity protection	yes
Power-on delay time	[s] 5
Inputs / outputs	
Number of inputs and outputs	Number of digital outputs: 2; Number of analogue outputs: 1
Inputs	
Inputs	counter reset

SM4100



Magnetic-inductive flow meter

SMR14DXXFRKG/US-100

Outputs	
Total number of outputs	2
Output signal	switching signal; analogue signal; pulse signal; IO-Link; (configurable)
Electrical design	PNP/NPN
Number of digital outputs	2
Output function	normally open / normally closed; (parameterisable)
Max. voltage drop switching output DC [V]	2
Permanent current rating of switching output DC [mA]	200
Number of analogue outputs	1
Analogue current output [mA]	4...20; (scalable)
Max. load [Ω]	500
Analogue voltage output [V]	0...10; (scalable)
Min. load resistance [Ω]	2000
Pulse output	flow rate meter
Short-circuit protection	yes
Type of short-circuit protection	pulsed
Overload protection	yes
Measuring/setting range	
Measuring range [ml/min]	5...3000
Display range [ml/min]	-1999...3600
Resolution [ml/min]	1
Set point SP [ml/min]	20...3000
Reset point rP [ml/min]	5...2984
Analogue start point ASP [ml/min]	0...2400
Analogue end point AEP [ml/min]	600...3000
Low flow cut-off LFC [ml/min]	< 60
Volumetric flow quantity monitoring	
Pulse value	0.001...3000 l
Pulse length [s]	0,008...2
Temperature monitoring	
Measuring range [$^{\circ}$ C]	-20...80
Resolution [$^{\circ}$ C]	0.2
Set point SP [$^{\circ}$ C]	-19.2...80
Reset point rP [$^{\circ}$ C]	-19.6...79.6
Analogue start point [$^{\circ}$ C]	-20...60
Analogue end point [$^{\circ}$ C]	0...80
In steps of [$^{\circ}$ C]	0.2

SM4100



Magnetic-inductive flow meter

SMR14DXXFRKG/US-100

Accuracy / deviations		
Flow monitoring		
Accuracy (in the measuring range)		$\pm (2 \% MW + 0,5 \% MEW)$
Repeatability		$\pm 0,2 \% MEW$
Temperature monitoring		
Accuracy	[K]	$\pm 2,5 (Q > 0,5 \text{ l/min})$
Response times		
Flow monitoring		
Response time	[s]	0.15; (dAP = 0, T19)
Delay time programmable dS, dr	[s]	0...50
Damping for the switching output dAP	[s]	0...5
Temperature monitoring		
Dynamic response T05 / T09	[s]	T09 = 40 (Q > 1 l/min)
Software / programming		
Parameter setting options	Flow monitoring; quantity meter; Preset counter; Temperature monitoring; hysteresis / window; normally open / normally closed; switching logic; current/ voltage/pulse output; start-up delay; display can be deactivated; Display unit	
Interfaces		
Communication interface	IO-Link	
Transmission type	COM2 (38,4 kBaud)	
IO-Link revision	1.1	
SDCI standard	IEC 61131-9	
IO-Link device ID	671d / 00 02 9Fh	
Profiles	Smart Sensor: Process Data Variable; Device Identification, Device Diagnosis	
SIO mode	yes	
Required master port type	A	
Process data analogue	3	
Process data binary	2	
Min. process cycle time	[ms]	4
Operating conditions		
Ambient temperature	[°C]	-10...60
Storage temperature	[°C]	-25...80
Protection	IP 67	
Tests / approvals		
EMC	DIN EN 60947-5-9	
Shock resistance	DIN IEC 68-2-27	20 g (11 ms)
Vibration resistance	DIN IEC 68-2-6	5 g (10...2000 Hz)
MTTF	[years]	144
Pressure Equipment Directive	Sound engineering practice; can be used for group 2 fluids; group 1 fluids on request	

SM4100



Magnetic-inductive flow meter

SMR14DXXFRKG/US-100

Mechanical data		
Weight [g]	537	
Materials	stainless steel (1.4404 / 316L); PBT-GF20; PC; FKM; TPE	
Materials (wetted parts)	stainless steel (1.4404 / 316L); PEEK; EPDM	
Process connection	threaded connection G 1/4 DN6 flat seal	
Displays / operating elements		
Display	Display unit	6 x LED, green (ml/min, l/h, l, m ³ , °C, 10 ³)
	switching status	2 x LED, yellow
	measured values	alphanumeric display, 4-digit
	programming	alphanumeric display, 4-digit
Remarks		
Remarks	MW = measured value MEW = Final value of the measuring range	
Pack quantity	1 pcs.	
Electrical connection		
Connector: 1 x M12; Contacts: gold-plated		
		

SM4100



Magnetic-inductive flow meter

SMR14DXXFRKG/US-100

Connection

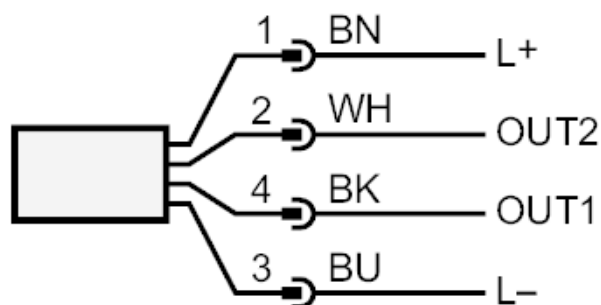

colours to DIN EN 60947-5-2

OUT1:

- switching output volumetric flow quantity monitoring
- Pulse output quantity meter
- signal output Preset counter
- IO-Link

OUT2:

- switching output volumetric flow quantity monitoring
- switching output Temperature monitoring
- analogue output volumetric flow quantity monitoring
- analogue output Temperature monitoring
- input counter reset

Core colours :

- BK = black
- BN = brown
- BU = blue
- WH = white

SM4100



Magnetic-inductive flow meter

SMR14DXXFRKG/US-100

Diagrams and graphs

Pressure loss

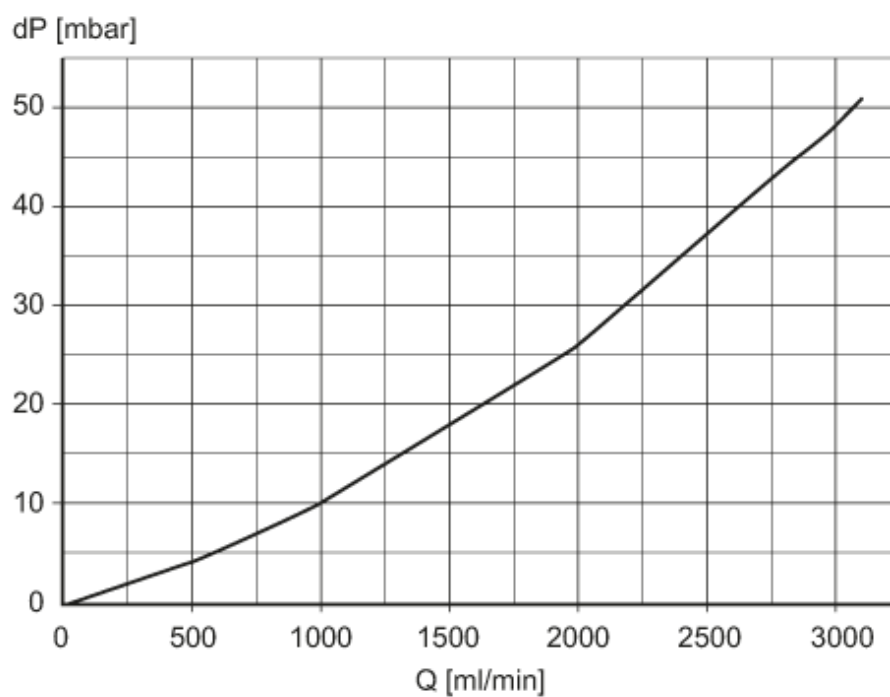

dP Pressure loss

Q volumetric flow quantity