

- > Port size: DN 20 ... 80, 3/4" ... 3" (ISO G/NPT)
- > High flow rate
- > All internal components captive
- > Clear, compact design
- > Solenoid interchangeable without tools (*Twist-on*)
- > Integrated silencer
- > One-piece diaphragm
- > Also available for solenoid version low temperature -40°C !

Twist-on



Technical features

Medium:

Air

Switching function:

Normally closed

Flow direction:

Determined

Mounting position:

Optional, preferably solenoid vertical on top

Port size:

G3/4, G1, G1 1/2,

G2, G2 1/2, G3

3/4 NPT, 1 NPT, 1 1/2 NPT,

2 NPT, 2 1/2 NPT

Operating pressure:

0,4 ... 7/8 bar (5,8 ... 101/116 psi)

Dusty gas temperature:

-20° ... $+85^{\circ}\text{C}$ (-4° ... $+185^{\circ}\text{F}$)

Coil gas temperature:

-40° ... $+85^{\circ}\text{C}$ (-40° ... $+185^{\circ}\text{F}$)

Ambient temperature:

-20° ... $+85^{\circ}\text{C}$ (-4° ... $+185^{\circ}\text{F}$)

Material:

Body: Aluminium

Seat seal: TPE

Internal parts: TPU

Technical data - standard models

Symbol	Port size	Orifice (mm)	Valve length (mm)	Flow kv value *1) (m ³ /h)	Operating pressure (bar)	Weight (kg)	Model
	G3/4	20	95	18	0,4 ... 8	0,5	8296300.8171.xxxxx
	3/4 NPT	20	95	18	0,4 ... 8	0,5	8297300.8171.xxxxx
	G1	25	95	22	0,4 ... 8	0,47	8296400.8171.xxxxx
	1 NPT	25	95	22	0,4 ... 8	0,47	8297400.8171.xxxxx
	G1 1/2	40	135	59	0,4 ... 8	1,18	8296600.8171.xxxxx
	1 1/2 NPT	40	135	59	0,4 ... 8	1,18	8297600.8171.xxxxx
	G2	50	169	80	0,4 ... 8	2,02	8296700.8171.xxxxx
	2 NPT	50	169	80	0,4 ... 8	2,02	8297700.8171.xxxxx
	G2 1/2	65	169	93	0,4 ... 8	2,3	8296800.8171.xxxxx
	2 1/2 NPT	65	169	93	0,4 ... 8	2,3	8297800.8171.xxxxx
	G3	80	239,5	172	0,4 ... 7	3,93	8296900.8171.xxxxx

xxxxx Please insert voltage and frequency codes

*1) Cv-value (US) \approx kv value x 1,2

Option selector

829★☆☆★.8171.★☆☆★

Thread form	Substitute
ISO G	6
NPT	7
Port size	Substitute
3/4	3
1	4
1 1/2	6
2	7
2 1/2	8
3 (only ISO G)	9
Valve options	Substitute
Flange version without valve body	54
Dusty gas temperature version -20 ... +100°C, Seat seal TPE, Ambient temperature -40 ... +85°C, Coil gas temperature -20 ... +85°C	62
Dusty gas temperature version -20 ... +140°C, Seat seal TPE, Ambient temperature -40 ... +85°C, Coil gas temperature -20 ... +85°C	63
Low temperature version only for solenoid 8xxx/9150, Dusty gas temperature version -45 ... +140°C, Seat seal TPE, Ambient temperature -40 ... +85°C, Coil gas temperature -20 ... +85°C	71

Frequency	Substitute
See table frequency codes	xx
Voltage	Substitute
See Voltage codes	xxx

Standard solenoid systems

Voltage and Frequency Solenoid 8171 *1)					
Code	Code	Voltage	Frequency	Power consumption	
				Inrush	Holding
024	00	24 V d.c.	-	12 W	12 W
024	50	24 V a.c.	50 Hz	23 VA	16 VA
110	50	110 V a.c.	50 Hz	23 VA	16 VA
120	60	120 V a.c.	60 Hz	23 VA	16 VA
230	50	230 V a.c.	50 Hz	23 VA	16 VA

*1) _{US} coil only

Electrical details for all solenoid systems

Design	DIN VDE 0580
Voltage range	±10%
Duty cycle	100% ED
Protection class	EN 60529 IP65
Socket	Form A acc. to DIN EN 175301-803 (included)

According to DIN VDE 0580 at a solenoid temperature of +20°C. At operating state temperature the input power of a coil decreases by up to ca. 30% due to physical reasons.



Additional solenoid systems

ATEX category	Protection class	Solenoid	Standard voltages
II3GD	EEx nA II T4 T 135°C	8176	24 V d.c., 110 V a.c., 230 V a.c.
II2GD	EEx me II T4 T 140°C	8186	24 V d.c., 110 V a.c., 230 V a.c.

Attention!

The conditions imposed on the Ex approvals lead to reduction of the permissible standard temperature ranges in the cases of explosion protected solenoids.

Additional solenoid systems

Option	Solenoid	Standard voltages
Solenoid version for low temperature -40°C	9151	24 V d.c., 110 V a.c., 230 V a.c.
Pulse Solenoid	8821	24 V d.c., 110 V a.c., 230 V a.c.
Solenoid version for low temperature -40°C	8001	24 V d.c., 110 V a.c., 230 V a.c.

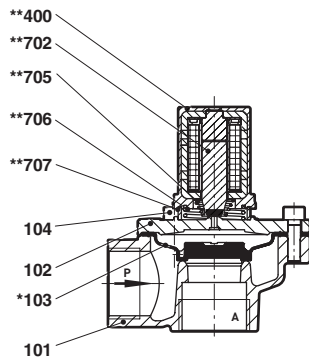
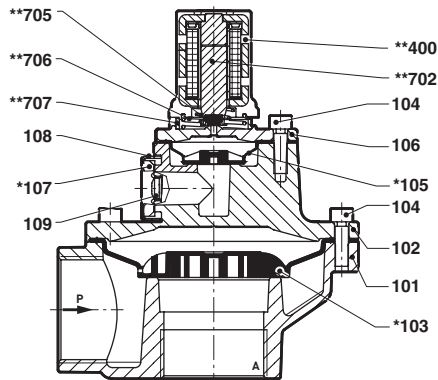
Section View
G3/4 ... 1
3/4 ... 1 NPT

G1 1/2 ... 3
1 1/2 ... 2 1/2 NPT

No.	Description
101	Valve body
102	Valve cover
*103	Diaphragm
104	Socket head cap screw
*105	Diaphragm
106	Valve cover
*107	Silencer
108	Silencer housing
109	Socket head cap screw
**400	Solenoid
**702	Core
**705	Pressure spring
**706	Pressure spring
**707	Silencer

*/**These individual parts form a complete wearing unit.

When ordering spare parts please state Cat. No. and Series No.

** Solenoid complete wearing unit, e. g. 8298000.8170.XXXXX for a solenoid 8170

Dimensions

G3/4 ... 1
3/4 ... 1 NPT

G1 1/2 ... 3
1 1/2 ... 2 1/2 NPT

Dimensions in mm
Projection/First angle

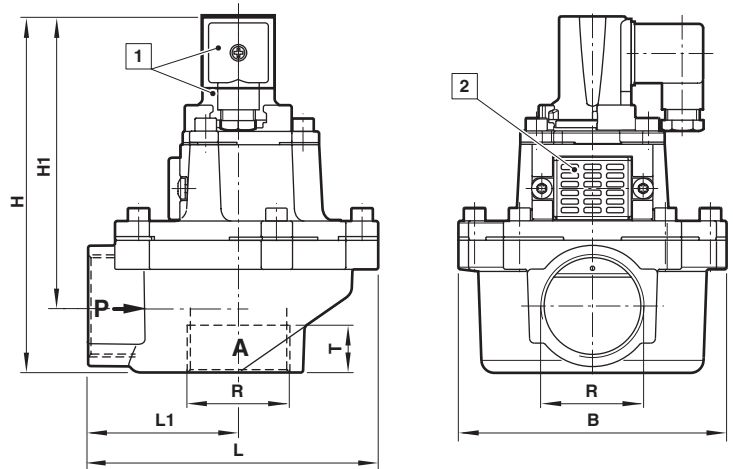
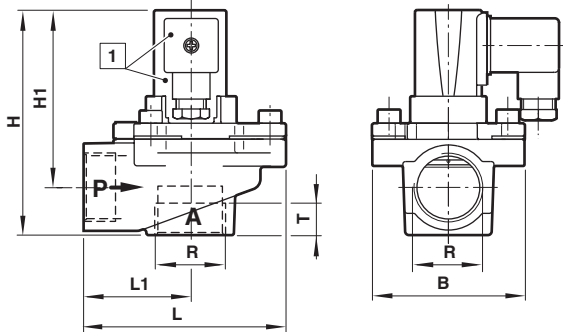

- 1 Solenoid rotatable 3 x 120°
Socket turnable 4 x 90°
(Socket included)
- 2 Silencer

Port size R	B	H	H1	L	L1	T	Model
G3/4	80	105,5	83	95	50	16	8296300.8171.xxxxx
3/4 NPT	80	105,5	83	95	50	14	8297300.8171.xxxxx
G1	80	105,5	83	95	50	18	8296400.8171.xxxxx
1 NPT	80	105,5	83	95	50	17	8297400.8171.xxxxx
G1 1/2	124,5	166	136	135	70	22	8296600.8171.xxxxx
1 1/2 NPT	124,5	166	136	135	70	18	8297600.8171.xxxxx
G2	140	190,5	149	170	95	25	8296700.8171.xxxxx
2 NPT	140	190,5	149	170	95	18	8297700.8171.xxxxx
G2 1/2	140	205,5	160	170	95	25	8296800.8171.xxxxx
2 1/2 NPT	140	205,5	160	170	95	24	8297800.8171.xxxxx
G3	196	221	169	239,5	143	33	8296900.8171.xxxxx

Note to Pressure Equipment Directive (PED):

The valves of this series are according to Art. 3 § 3 of the Pressure Equipment Directive (PED) 97/23/EG. This means interpretation and production are in accordance to engineers practice wellknown in the member countries.

The CE-sign at the valve refers not to the PED. Thus the declaration of conformity is not longer applicable for this directive.

Note to Electromagnetic Compatibility Guideline (EEC):

The valves shall be provided with an electrical circuit which ensures the limits of the harmonised standards EN 61000-6-3 and EN 61000-6-1 are observed, and hence the requirements of the Electromagnetic Compatibility Guideline (2004/108/EG) satisfied.