

W1G200-EC87-20

EC axial fan - ESM

sickle-shaped blades (S series)

ESM fan housing



ebm-papst Mulfingen GmbH & Co. KG

Bachmühle 2 · D-74673 Mulfingen

Phone +49 7938 81-0

Fax +49 7938 81-110

info1@de.ebmpapst.com

www.ebmpapst.com

Limited partnership · Headquarters Mulfingen

Amtsgericht (court of registration) Stuttgart · HRA 590344

General partner Elektrobau Mulfingen GmbH · Headquarters Mulfingen

Amtsgericht (court of registration) Stuttgart · HRB 590142

Nominal data

Type	W1G200-EC87-20		
Motor	M1G055-BD		
Phase		1~	1~
Nominal voltage	VAC	230	230
Frequency	Hz	50/60	50/60
Method of obtaining data		ml	
Speed (rpm)	min ⁻¹	1300	900
Power consumption	W	8	
Current draw	A	0.07	
Max. back pressure	Pa	23	
Max. back pressure	in. wg	0.09	
Min. ambient temperature	°C	-30	-30
Max. ambient temperature	°C	50	50

ml = Max. load · me = Max. efficiency · fa = Free air · cs = Customer specification · ce = Customer equipment
Subject to change



Technical description

Weight	0.88 kg
Size	200 mm
Motor size	55
Blade material	PA plastic
Fan housing material	PP plastic
Number of blades	5
Airflow direction	V
Direction of rotation	Counterclockwise, viewed toward rotor
Degree of protection	IP55; only with suitable plug, to be installed by customer
Insulation class	"B"
Moisture (F) / Environmental (H) protection class	H1+
Max. permitted ambient temp. for motor (transport/storage)	+80 °C
Min. permitted ambient temp. for motor (transport/storage)	-40 °C
Installation position	Any
Condensation drainage holes	None
Mode	S1
Motor bearing	Ball bearing
Technical features	<ul style="list-style-type: none"> - Speed selection max./min. - ESM+ expandable with plug-in module - Soft start - Thermal overload protection for motor
Speed levels	2
EMC immunity to interference	According to EN 61000-6-2 (industrial environment)
EMC circuit feedback	According to EN 61000-3-2/3
EMC interference emission	According to EN 61000-6-3 (household environment)
Touch current according to IEC 60990 (measuring circuit Fig. 4, TN system)	<= 0.25 mA
Electrical hookup	Plug
Motor protection	Thermal overload protector (TOP) internally connected
Protection class assignment	<p>II; This component for installation may have several local protection classes. This information relates to this component's basic design.</p> <p>The final protection class is based on the component's intended installation and connection.</p>
Conformity with standards	EN 60034-1; EN 60204-1; EN 60335-1; EN 60335-2-24; EN 60335-2-80; EN 60335-2-89; CE; UKCA
Approval	VDE; CSA C22.2 No. 77; EAC; UL 1004-3

EC axial fan - ESM

sickle-shaped blades (S series)

ESM fan housing

Product drawing

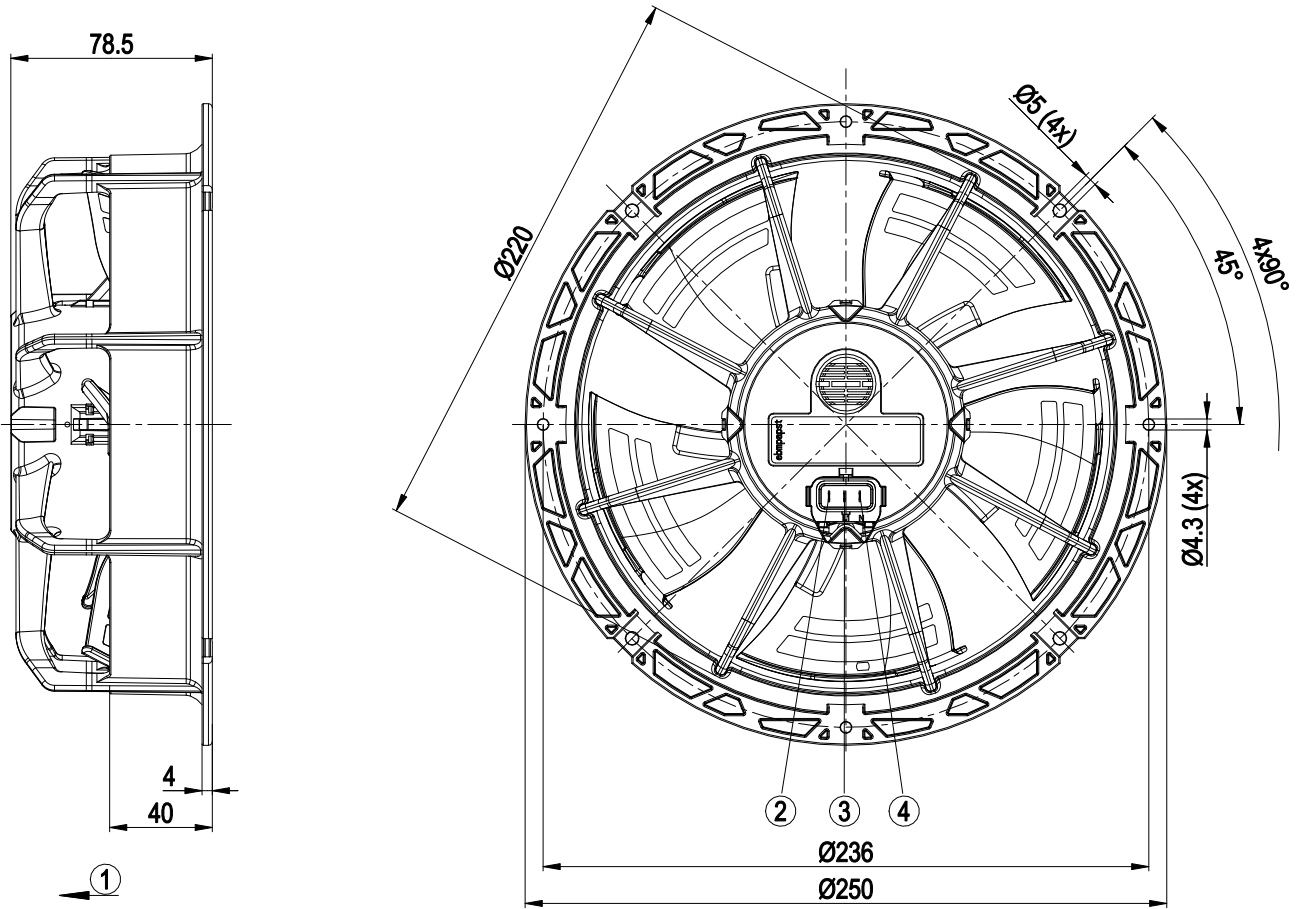

1	Direction of air flow "V"
2	Pin S, speed selection (flat plug 2.8 x 0.5)
3	Pin L1, phase (flat plug 2.8 x 0.5)
4	Pin N, neutral conductor (flat plug 2.8 x 0.5)



Connection diagram

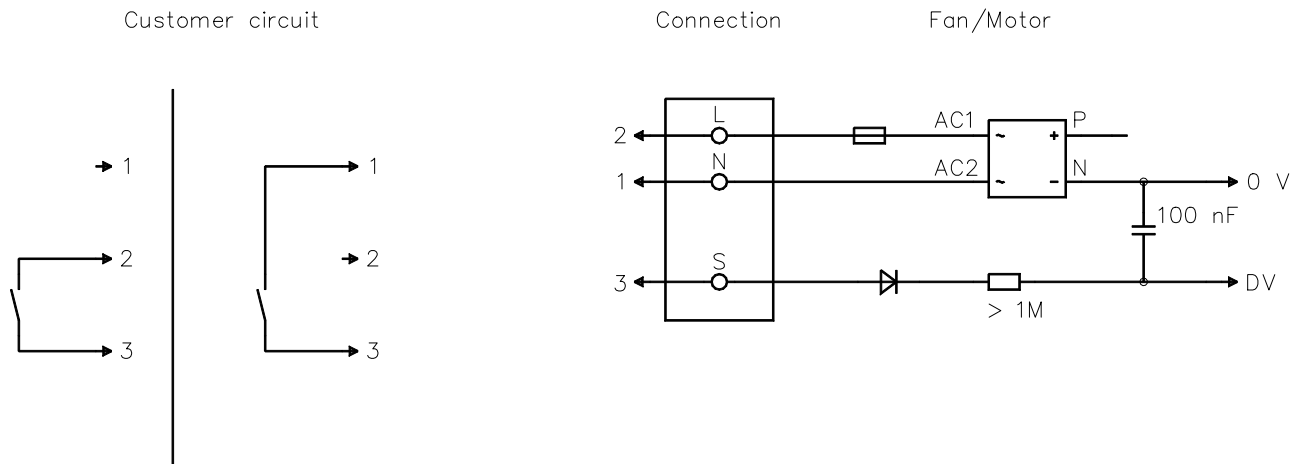

No.	Conn.	Designation	Color	Function/assignment
1	N		blue	Neutral conductor
2	L		black	Power supply 230 VAC, 50-60 Hz, see nameplate for voltage range
3	S		brown	Speed selection: switch open speed 1 (fast), switch closed speed 2 (slow)

EC axial fan - ESM

sickle-shaped blades (S series)

ESM fan housing

Curves: Air performance 50 Hz

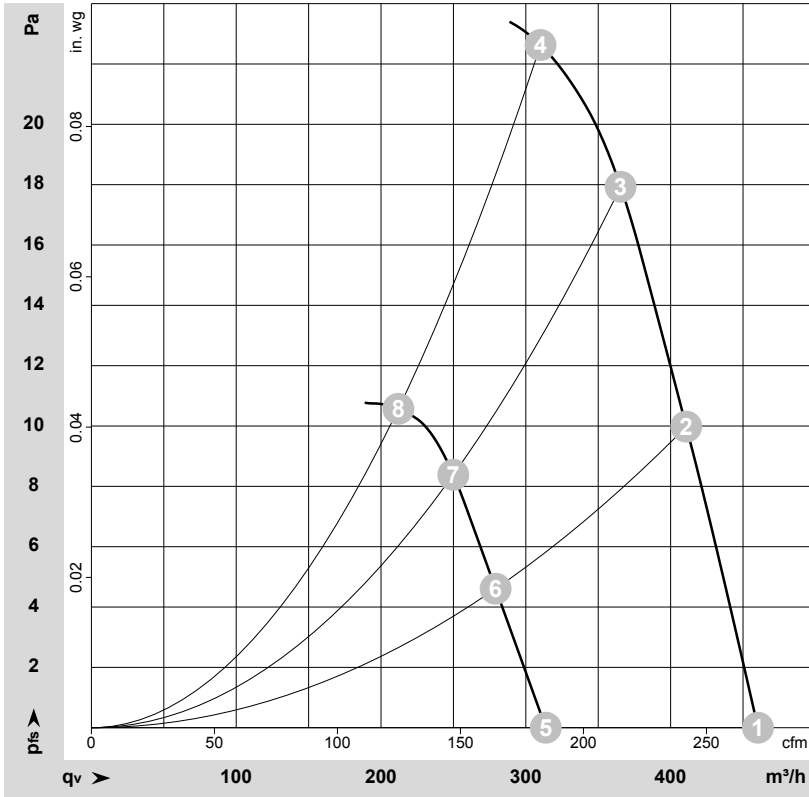

$\rho = 1.15 \text{ kg/m}^3 \pm 2 \%$

Measurement: LU-113354-1
Measurement: LU-113366-1

Air performance measured according to ISO 5801 installation category A. For detailed information on the measurement setup, contact ebm-papst. Intake sound level: Sound power level according to ISO 13347 / sound pressure level measured at 1 m distance from fan axis. The values given are valid under the specified measuring conditions and may vary due to conditions of installation. For deviations from the standard configuration, the parameters have to be checked on the installed unit.

Measured values

	Stage	Wired	U	f	n	P _{ed}	I	LpA _{in}	LwA _{in}	q _v	p _{fs}	q _v	p _{fs}
			V	Hz	min ⁻¹	W	A	dB(A)	dB(A)	m ³ /h	Pa	cfm	in. wg
1	1	1~	230	50	1300	7.0	0.06	42	50	460	0	270	0.00
2	1	1~	230	50	1300	8.0	0.07	41	49	410	10	240	0.04
3	1	1~	230	50	1300	8.0	0.07	40	48	365	18	215	0.07
4	1	1~	230	50	1300	8.0	0.07	43	51	310	23	180	0.09
5	2	1~	230	50	900	3.00	0.03	33	41	315	0	185	0.00
6	2	1~	230	50	900	4.0	0.04	32	41	280	5	165	0.02
7	2	1~	230	50	900	4.0	0.04	31	40	250	8	145	0.03
8	2	1~	230	50	900	4.0	0.04	33	42	210	11	125	0.04

Wired = Wiring · U = Voltage · f = Frequency · n = Speed (rpm) · P_{ed} = Power consumption · I = Current draw · LpA_{in} = Sound pressure level intake side · LwA_{in} = Sound power level intake side
q_v = Air flow · p_{fs} = Pressure increase

