

N0033A

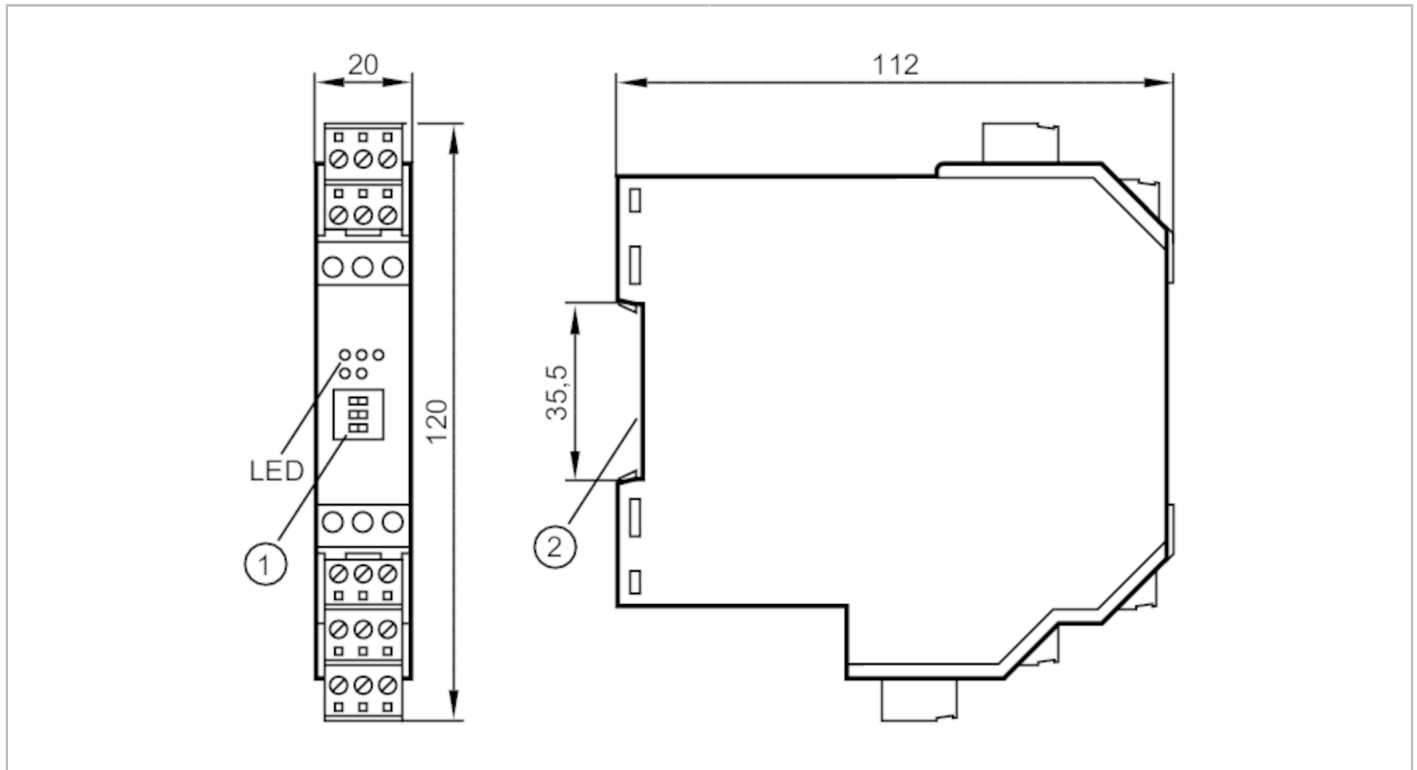

Switching amplifiers for Namur sensors

NV1221/230VAC/RL/1D/1G



Application	
Application	short-circuit monitoring; Wire monitoring
Electrical data	
Operating voltage tolerance [%]	-10...10
Operating voltage [V]	< 230 AC
Max. power consumption [VA]	1.3
Number of channels	2
Outputs	
Electrical design	relay; (per channel: 1 changeover contact)
Contact rating	253 V AC / 2 A / cos phi > 0,7 // 40 V DC / 2 A; (ohmic resistance)
Switching frequency AC [Hz]	10
Operating conditions	
Ambient temperature [°C]	-20...60
Protection	IP 20
Tests / approvals	
Approval	PTB 02 ATEX 2035; TIIS TC16048; IECEx PTB 17.0023
ATEX marking	Ex II (1) G [Ex ia Ga] IIC Ex II (1) D [Ex ia Da] IIIC
EMC	EN 50081-2 (1993) EN 61326-1 (2006)
MTTF [years]	458

N0033A



Switching amplifiers for Namur sensors

NV1221/230VAC/RL/1D/1G

Mechanical data		
Weight [g]	212	
Switching cycles mechanical	10 million	
Displays / operating elements		
Display	switching status	2 x LED, yellow
	operation	LED, green
	function	2 x LED, red
Remarks		
Remarks	Caution The control monitor must be mounted outside the hazardous area. Free terminals must not be used.	
Pack quantity	1 pcs.	

N0033A



Switching amplifiers for Namur sensors

NV1221/230VAC/RL/1D/1G

Electrical connection

terminals: ...2.5 mm²

Connection

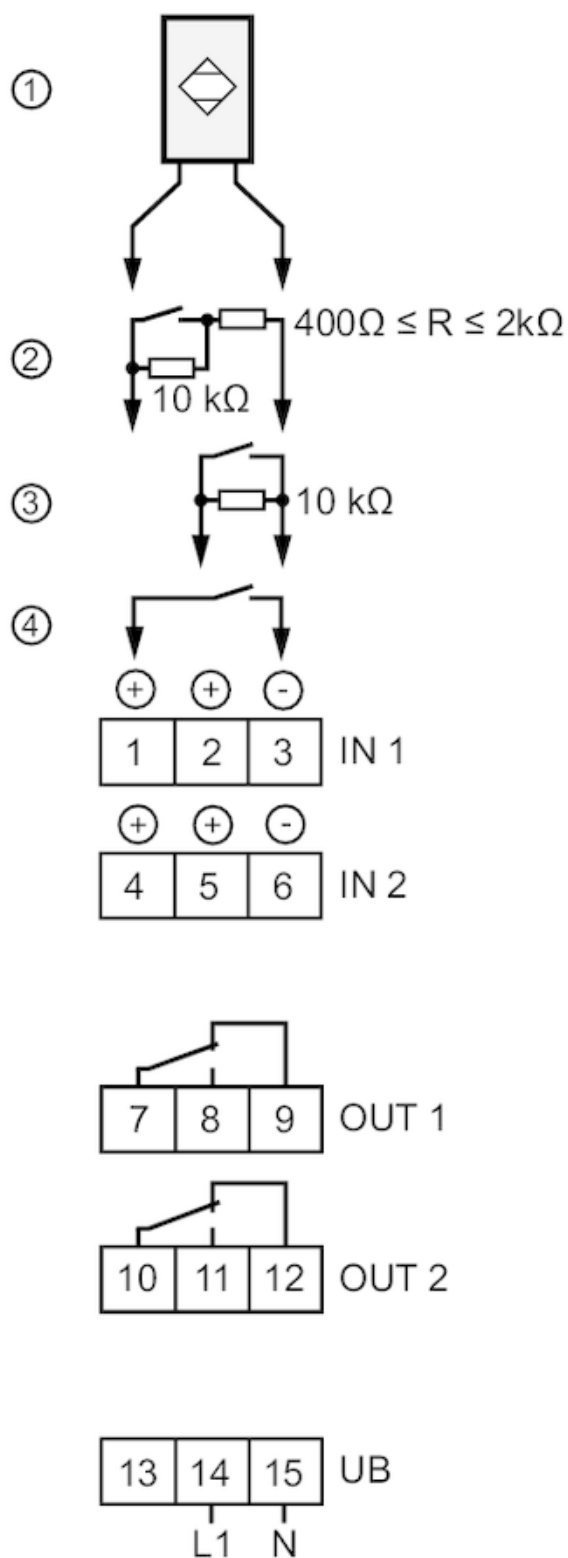

N0033A



Switching amplifiers for Namur sensors

NV1221/230VAC/RL/1D/1G

Other data

Maximum values for control circuit

in protection rating intrinsic safety	[EEx ia] IIC	[EEx ia] IIB	[EEx ib] IIC	[EEx ib] IIB
Voltage [V]	10.6	10.6	10.6	10.6
Current [mA]	19.1	19.1	19.1	19.1
Power [mW]	51	51	51	51
External inductance [mH]	97	390	97	390
External capacitance [μ F]	2.32	16.2	2.32	16.2