



Model Number

AS 08/15

Stop screw for series F2 sensors

Features

- Safely sets the mechanical end stop position

Technical Data

Mechanical specifications

Operating force	min. 1.5 N max. 2000 N
Material	Steel 1.1191 / AISI 1045 (C45)
Dimensions	
A	M8 x 1
B	2.2 mm
C	5.8 mm
L	12 mm
L1	31.7 mm
L2	29.8 mm
L3	27.5 mm
Tightening torque	max. 8 Nm

General information

Note	If necessary, properly secure the lock nut
Scope of delivery	Stop screw Counter nut

Dimensions

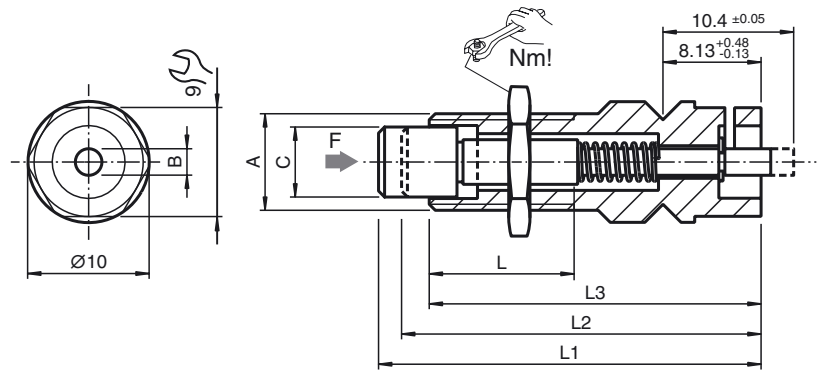

Release date: 2015-02-02 16:35 Date of issue: 2015-02-02 189990_eng.xml