

Ball Pillow Block Bearings KP and SSKP, light series

Material KP: Housing: from Zinc die cast,
Rolling bearing: from bearing steel.

Material SSKP: Housing: Stainless steel
1.4301 (AISI 304). Rolling bearing:
Stainless steel 1.4125 (AISI 440C), lubricated with
grease FM 222 for food processing machinery, with
registration FDA, CIFA, KPF2K-20, NSF H1.

The rolling bearing can be swiveled when mounting to
compensate shaft misalignment. The shaft will
get fastened with 2 set screws. Lubricated for life at
normal operating conditions.

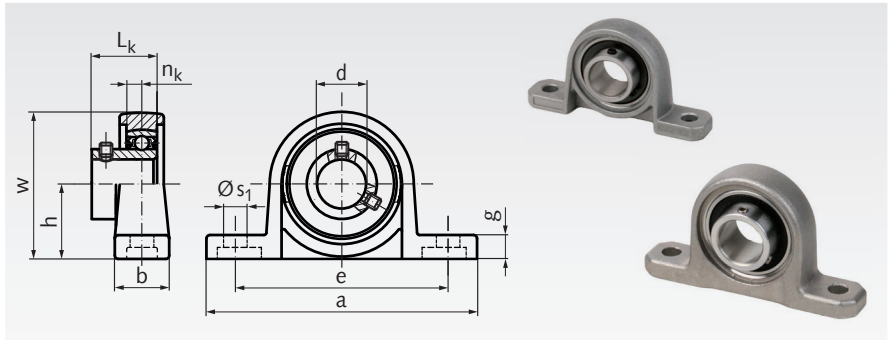

Ordering Details: e.g.: Product No. 625 608 00, Ball Pillow Block Bearing KP 08, Bore 8mm

Product No. KP	Product No. SSKP	No.	d mm	a mm	b mm	e mm	g mm	h mm	s ₁ mm	w mm	L _k mm	n _k mm	Bearing-Load Rating ¹⁾				Weight KP g	Weight SSKP g
													KP		SSKP			
													dyn. C kN	stat.C ₀ kN	dyn. C kN	stat.C ₀ kN		
625 608 00	-	08	8	55	13	42	5	15	4,8	29	11,5	3,5	4,2	1,6	-	-	70	-
625 610 00	625 996 10	000	10	67	16	53	6	18	7	35	15	4	4,7	2,0	4,0	1,6	60	70
625 612 00	625 996 12	001	12	71	16	56	6	19	7	38	15	4	5,2	2,45	4,4	1,95	70	100
625 615 00	625 996 15	002	15	80	16	63	7	22	7	43	16,5	4,5	5,7	2,9	4,85	2,3	100	140
625 617 00	625 996 17	003	17	85	18	67	7	24	7	47	17,5	5	6,1	3,35	5,2	2,7	130	190
625 620 00	625 996 20	004	20	100	20	80	9	28	10	55	21	6	9,55	5,15	8,1	4,1	190	230
625 625 00	625 996 25	005	25	112	20	90	10	32	10	62	22,5	6	10,3	5,95	8,75	4,75	230	290

¹⁾ Maximum radial load if axial force = 0. The axial load rating is approx. 20% of the radial load rating.

Ball Pillow Block Bearings UP and SSUP, light series, with Eccentric Ring

Material UP: Housing: from Zinc die cast,
Rolling bearing: from bearing steel.

Material SSUP: Housing: Stainless steel
1.4301 (AISI 304). Rolling bearing:
Stainless steel 1.4125 (AISI 440C), lubricated with
grease FM 222 for food processing machinery, with
registration FDA, CIFA, KPF2K-20, NSF H1.

The rolling bearing can be swiveled when mounting to
compensate shaft misalignment. During
assembly, the eccentric ring and the inner bearing
ring are turned against each other to clamp the
shaft. The eccentric ring is additionally secured on
the shaft with 1 set screw. Lubricated for life at
normal operating conditions.

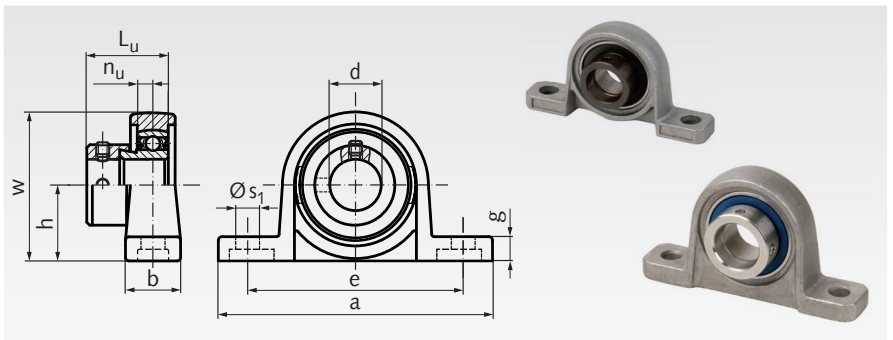

Ordering Details: e.g.: Product No. 625 710 00, Ball Pillow Block Bearing UP 000, Bore 10mm

Product No. UP	Product No. SSUP	No.	d mm	a mm	b mm	e mm	g mm	h mm	s ₁ mm	w mm	L _u mm	n _u mm	Bearing-Load Rating ¹⁾				Weight UP g	Weight SSUP g
													UP		SSUP			
													dyn. C kN	stat.C ₀ kN	dyn. C kN	stat.C ₀ kN		
625 710 00	625 997 10	000	10	67	16	53	6	18	7	35	17,5	4	4,6	1,98	4,0	1,6	70	100
625 712 00	625 997 12	001	12	71	16	56	6	19	7	38	17,5	4	5,1	2,27	4,4	1,95	80	110
625 715 00	625 997 15	002	15	80	16	63	7	22	7	43	18,5	4,5	5,6	2,55	4,85	2,3	100	140
625 717 00	625 997 17	003	17	85	18	67	7	24	7	47	21,0	5	6,0	2,84	5,2	2,7	130	190
625 720 00	625 997 20	004	20	100	20	80	9	28	10	55	25,5	6	9,35	4,55	8,1	4,1	210	300
625 725 00	625 997 25	005	25	112	20	90	10	32	10	62	25,5	6	10,1	5,05	8,75	4,75	290	320

¹⁾ Maximum radial load if axial force = 0. The axial load rating is approx. 20% of the radial load rating.

Shaft Connection with Eccentric Ring

The eccentric ring has an eccentric recess, a radial bore for hook wrench with pin
and a set screw. The inner ring of the bearing insert has an eccentric shoulder. For
assembly, the eccentric ring and the inner bearing ring must be turned against
each other to clamp the shaft. Finally the eccentric ring must be secured with the
set screw.

