

CORE DIMENSIONS:

A	16.00 [.630]	+	0.30 [.012]
B	9.00 [.354]	+	0.30 [.012]
C	28.00 [1.102]	+	0.50 [.020]
		-	0.30 [.012]
D	7.50 [.295]	+	0.20 [.008]
E	5.60 [.220]	+	0.30 [.012]

Weight/1000 18.18 kgs 40.09 lbs.
(Per Pair)

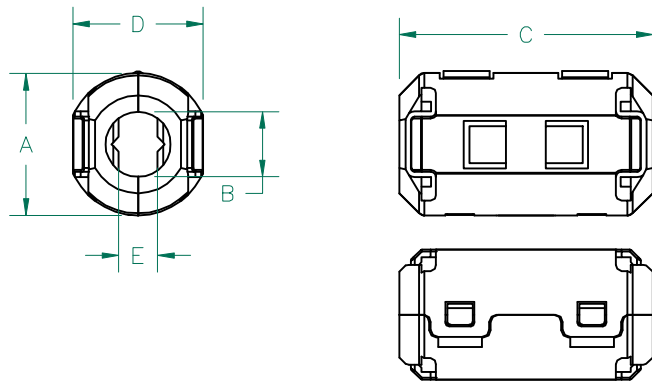

CASE DIMENSIONS:

A	19.70 [.776]	+	0.40 [.016]
B	9.00 [.354]	+	0.30 [.012]
C	35.25 [1.388]	+	0.50 [.020]
D	18.25 [.719]	+	0.30 [.012]
E	5.38 [.212]	+	REF.

UNCONTROLLED DOCUMENT

IMPEDANCE (Z)			
Frequency	25 MHz	100 MHz	300 MHz
Nominal (REF)	120 Ω	220 Ω	360 Ω
Minimum	- Ω	176 Ω	- Ω

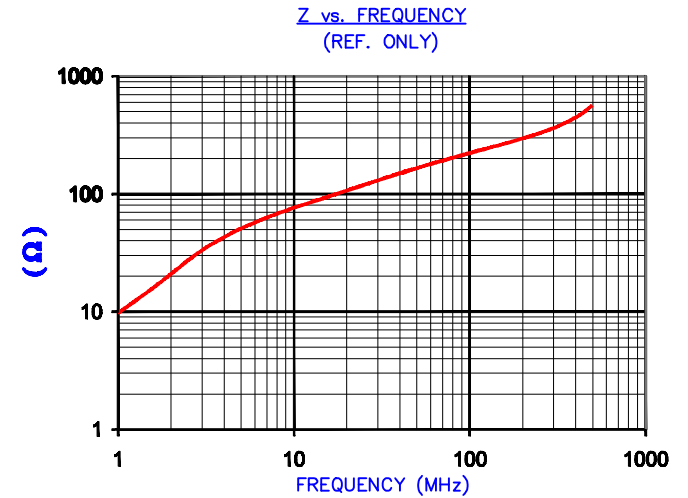

AGILENT E4991A Impedance/Material Analyzer
HP 16092A-Test Fixture REF 3219

NOTES:

1. CASE FLAMMABILITY RATING: UL94 V-0
2. CASE MATERIAL: HALOGEN FREE NYLON
3. ASSEMBLED PART #: 28A2809-0A2
4. CORE PART #: 28A2736-000
5. CASE COLOR: BLACK -"0A2"

DIMENSIONS ARE IN mm [INCHES].				This print is the property of Laird Tech. and is loaned in confidence subject to return upon request and with the understanding that no copies shall be made without the written consent of Laird Tech. All rights to design or invention are reserved.					
PROJECT/PART NUMBER:	28A2809-0A2			REV	C	PART TYPE:	FERRITE SNAP-ON	DRAWN BY:	TMB
C	UPDATE DIMENSION	10/15/10	Jcai	DATE:	09/17/08	SCALE:	NTS	MATERIAL:	NiZn Ferrite
B	CHANGE DIMENSION C AND D	03/10/09	JRK	CAD #	28A2809-0A2-C	TOOL #	-		
A	ORIGINAL DRAFT	09/17/08	TMB						
REV	DESCRIPTION	DATE	INT						