



KISSLING SINGLE POLE POWER RELAYS

Series 29 / 400A - from TE Connectivity (TE)

The economical 29 series single coil relays with 400 amps (A) are developed using our competence and expertise gathered over decades of manufacturing to meet even the most demanding operating requirements.

This single coil system relay features high shock and vibration resistance predominantly from its careful design and an optimized magnetic circuit. The sealing technology used in these relays meets both the IP67 and IP6K9K (Steam pressure cleaning) protection standard. This relay series is well suited for various applications in severe conditions.

Other important advantages are low heat generation in the contact area based on low contact voltage drop, a compact design, low holding current, silver alloy contact material and the use of mechanical and high thermal stability insulating compounds. Both the terminals and the housing are protected against corrosion.

By equipping these relays with blow-out magnets, contact voltages are also achievable up to 250VDC. The use of blow-out magnets are also recommended for contact voltages over 48VDC and for inductive load applications to maintain long contact life at all voltages.

Also available are various bracket styles to meet your installation conditions and suppression devices to eliminate electromagnetic interference at the coil and optional auxiliary contacts.

Features

- Sealed housing conforms to IP6K9K
- Robust design
- Minimized coil current
- Variety of configuration options
- 6G shock and 4G vibration resistant
- Main contact current rated for continuous current and 100% duty cycle
- Efficient coil and magnetic circuit design with switching properties and holding current requirements

Applications

- Truck
- Bus
- Ground support vehicles
- Construction and agricultural vehicles
- Fork lift applications

Circuits

NO-Contact

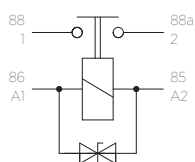

Suppression diode

NO-Contact/Auxiliary-Contact

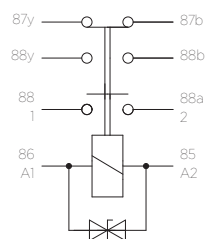

Suppression diode

SERIES 29

400A

Specification

Technical Data

| | |
|-----------------------|--|
| Temperature range | -40°C to +85°C |
| Protection | IEC 60529 & DIN 40050-9 - IP67 (0,2bar, 1min) and IP6K9K |
| Shock | 6g / 11msec |
| Vibration | 4g / 50-2000Hz |
| Thread sizes / Torque | M4 = 2.0 - 2.2Nm M12 = 18 - 22Nm |

Electrical Characteristics

| | |
|---------------------------------|-----------------------------|
| Min. Insulation resistance | 100MΩ |
| After live or environment | 50MΩ |
| Dielectric withstanding voltage | 1050VAC / 1min at 50Hz |
| Max. Contact drop, initial | 150mV |
| Contact drop after life test | 175mV |
| Continuous current | 400A |
| Overload | 3200A - 1sec / 800A - 20sec |

| Rated contact load | 12 / 24 / 28VDC | 80VDC |
|--------------------|------------------|------------------|
| Resistive load | 400A | 300A |
| Cycles | 100.000 | 100.000 |
| Mechanical life | 2.000.000 cycles | 2.000.000 cycles |

| Coil Data | 12VDC | 24 / 28VDC | 80VDC |
|-----------------------|----------|------------|------------|
| Voltage range | 9-16VDC | 18-32VDC | 60-90VDC |
| Nominal voltage | 12VDC | 28VDC | 80VDC |
| Pick up voltage max. | 9VDC | 18VDC | 60VDC |
| Drop out voltage min. | ≤ 2VDC | ≤ 4VDC | ≤ 8VDC |
| Coil resistance | 9Ω ± 10% | 36Ω ± 10% | 350Ω ± 10% |
| Coil current approx. | 1.33A | 0.78A | 0.23A |
| Coil power approx. | 22W | 22W | 19W |

Operating times NO-Contact relay

| | |
|-------------------|---|
| Operate | max. 60msec |
| Bounce | max. 5msec |
| Release | max. 30msec |
| Wire Section | min. 150mm ² / 0.233 sq.inch / MCM 300 |
| Mounting position | optional |

SERIES 29

400A

Technical drawings

Side mounting

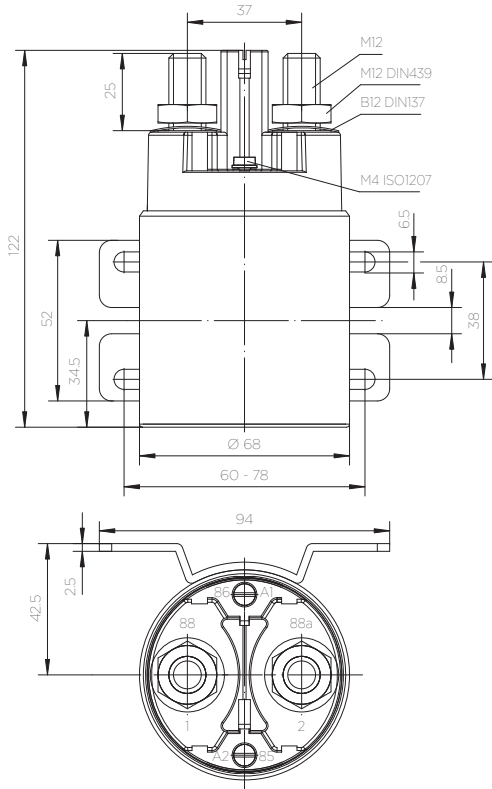

Bottom mounting

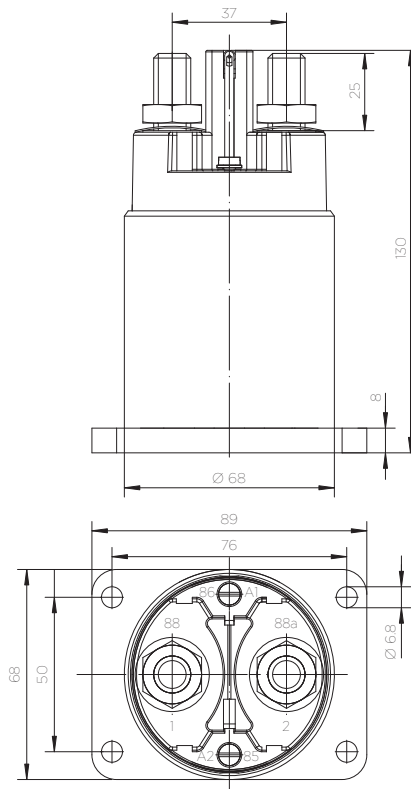

Options: Magnetic blowouts

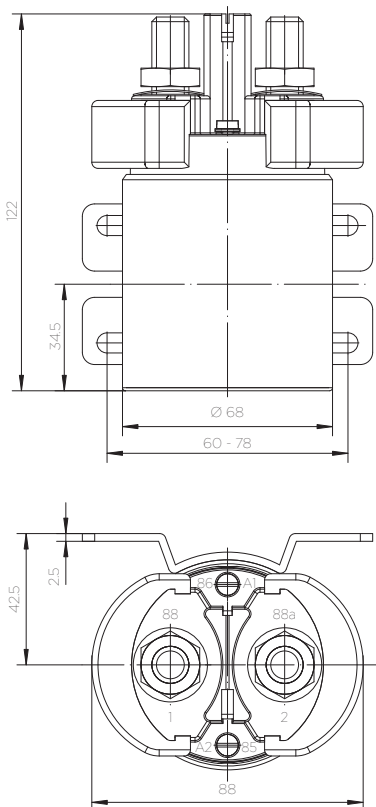

Options: Auxiliary contacts

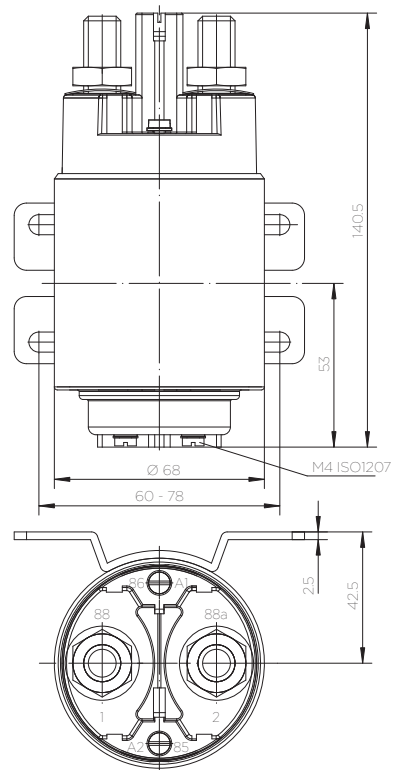

Ordering Information

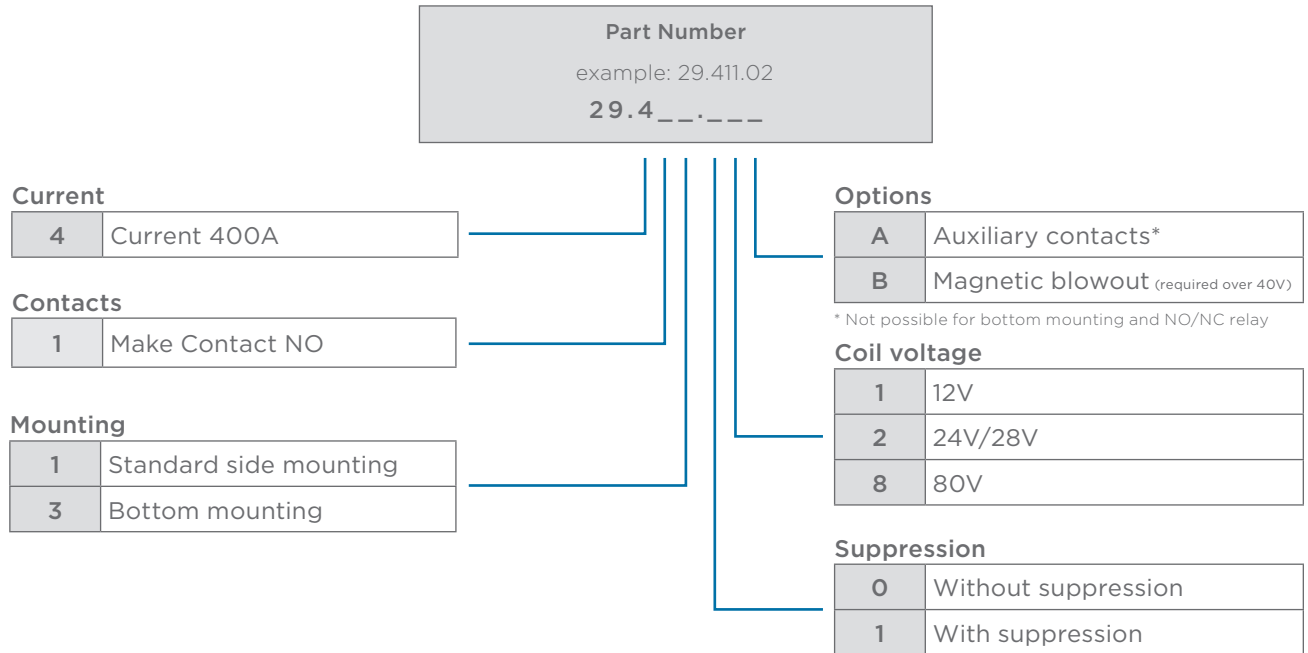

te.com

TE Connectivity, TE, TE connectivity (logo), KISSLING (logo) and KISSLING (word) are trademarks owned or licensed by the TE Connectivity family of companies. All other logos, products and/or company names referred to herein might be trademarks of their respective owners.

The information given herein, including drawings, illustrations and schematics which are intended for illustration purposes only, is believed to be reliable. However, TE Connectivity makes no warranties as to its accuracy or completeness and disclaims any liability in connection with its use. TE Connectivity's obligations shall only be as set forth in TE Connectivity's Standard Terms and Conditions of Sale for this product and in no case will TE Connectivity be liable for any incidental, indirect or consequential damages arising out of the sale, resale, use or misuse of the product. Users of TE Connectivity products should make their own evaluation to determine the suitability of each such product for the specific application.