

C.A 10141



Conductivity meter

Thank you for purchasing this **C.A 10141 conductivity meter**.

For best results with your instrument:

- **read** these operating instructions carefully,
- **comply** with the precautions for use.



Information or useful tip.



Battery.



The product is declared recyclable following an analysis of the life cycle in accordance with standard ISO 14040.



Chauvin Arnoux has adopted an Eco-Design approach in order to design this appliance. Analysis of the complete life-cycle has enabled us to control and optimize the effects of the product on the environment. In particular this appliance exceeds regulation requirements with respect to recycling and reuse.



The CE marking indicates conformity with European directives, in particular LVD and EMC.



The rubbish bin with a line through it indicates that, in the European Union, the product must undergo selective disposal in compliance with Directive WEEE 2012/19/EU. This equipment must not be treated as household waste.

PRECAUTIONS FOR USE

This instrument is compliant with safety standard IEC 61010-2-030, for voltages 5V with report to ground. Failure to observe the safety instructions may result in electric shock, fire, explosion, and destruction of the instrument and of the installations.

- The operator and/or the responsible authority must carefully read and clearly understand the various precautions to be taken in use. Sound knowledge and a keen awareness of electrical hazards are essential when using this instrument.
- Observe the conditions of use, namely the temperature, the relative humidity, the altitude, the degree of pollution, and the place of use.
- Do not use the instrument if it seems to be damaged, incomplete, or poorly close.
- Before each use, check the condition of the housing. Any item of which the insulation is deteriorated (even partially) must be set aside for repair or scrapping.
- All troubleshooting and metrological checks must be done by competent, accredited personnel.

CONTENTS

1. FIRST USE	4
1.1. Delivery condition	4
1.2. Accessories	5
1.3. Replacement parts	5
1.4. Inserting the batteries	6
2. PRESENTATION OF THE INSTRUMENT	7
2.1. C.A 10141	7
2.2. Functions of the instrument	8
2.3. Keypad	8
2.4. Display	9
2.5. Setting the time	10
2.6. Prop	10
3. USE IN STAND-ALONE MODE	11
3.1. Connecting the cell	11
3.2. Calibration	11
3.3. Conductivity measurement	16
3.4. Resistivity measurement	18
3.5. TDS measurement	19
3.6. Salinity measurement	19
3.7. Recording the measurements	20
3.8. Errors	20
4. USE IN RECORDING MODE	21
4.1. Connection	21
4.2. Get Data Logger Transfer software	21
4.3. USB link	21
4.4. Data Logger Transfer software	23
5. TECHNICAL CHARACTERISTICS	26
5.1. Reference conditions	26
5.2. Electrical characteristics	26
5.3. Memory	28
5.4. USB	28
5.5. Power supply	28
5.6. Environmental conditions	29
5.7. Mechanical characteristics	29
5.8. Compliance with international standards	29
5.9. Electromagnetic compatibility (CEM)	29
6. MAINTENANCE	30
6.1. Cleaning	30
6.2. Replacement of batteries	31
6.3. Serial number	31
6.4. Calibration log	31
6.5. Embedded software version	31
6.6. Updating the embedded software	31
7. WARRANTY	34
8. APPENDIX 1: NONLINEAR TEMPERATURE CORRECTION OF THE CONDUCTIVITY	35
9. APPENDIX 2: SALINITY CALCULATION	36

1. FIRST USE

1.1. DELIVERY CONDITION

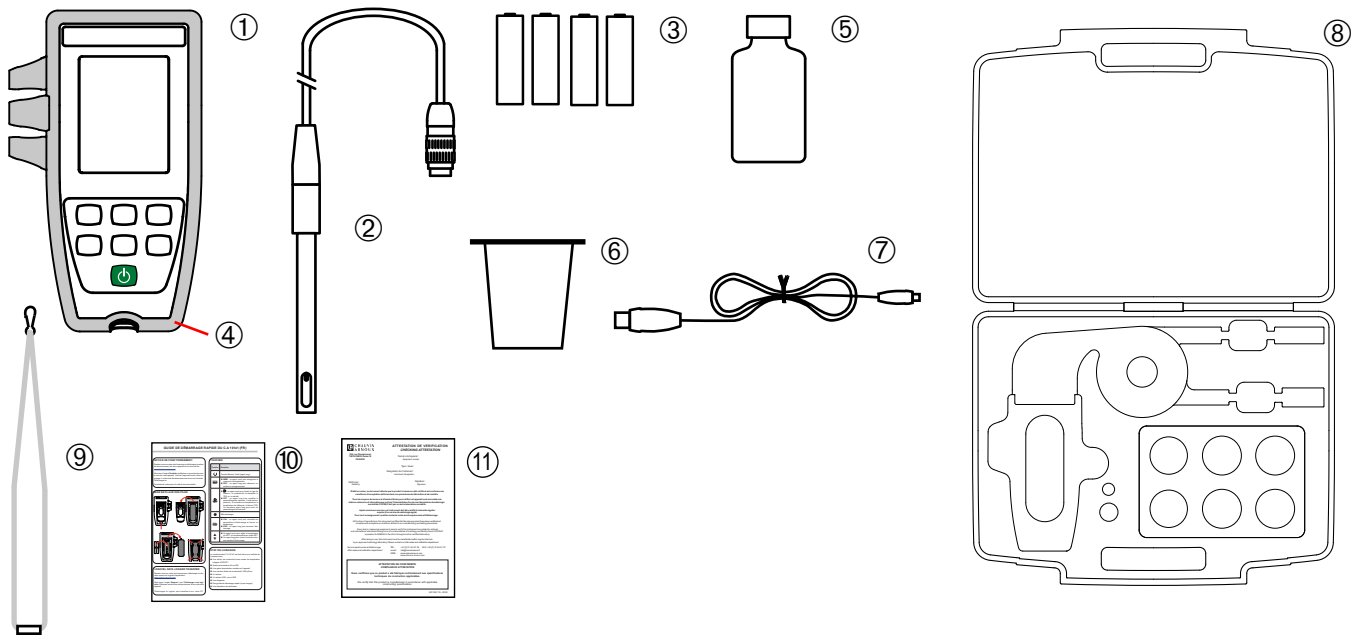

- ① One C.A 10141 conductivity meter.
- ② One XCP4ST1 conductivity cell with integrated temperature probe.
- ③ Four AA or LR6 alkaline batteries.
- ④ One protective sheath fitted on the instrument.
- ⑤ One standard solution having a conductivity of $1408\mu\text{S}/\text{cm}$.
- ⑥ One beaker.
- ⑦ One USB to micro USB cable.
- ⑧ One carrying case.
- ⑨ One wrist strap.
- ⑩ Quick start guides (one per language).
- ⑪ One certificate of verification.

1.2. ACCESSORIES

- One adapter, DIN male to S7 female (for the cell) and female jack (for a PT1000 temperature probe). The cable is 1m long.

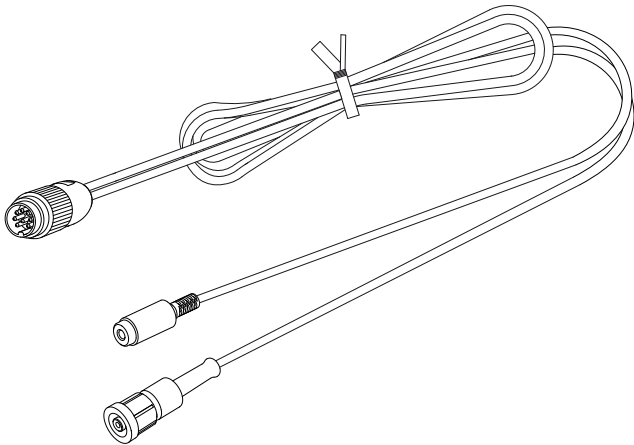

- One adapter DIN male to BNC female (for the cell) and female jack (for a PT1000 temperature probe). The cable is 10cm long.

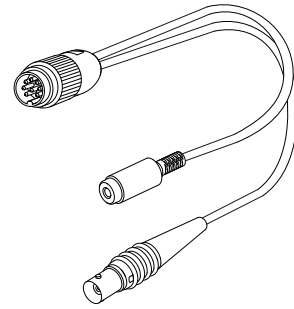

- One USB power adapter with USB to micro USB cable

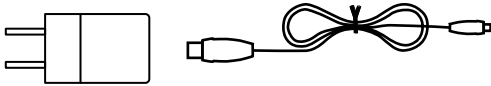

- One standard solution having a conductivity of 12,85mS/cm
- One standard solution having a conductivity of 147 μ S/cm.

1.3. REPLACEMENT PARTS

- One XCP4ST1 conductivity/temperature cell
- One standard solution having a conductivity of 1408 μ S/cm
- One set of 3 plastic beakers
- One protecting sheath

For the accessories and spares, consult our web site:
www.chauvin-arnoux.com

1.4. INSERTING THE BATTERIES

- Turn the instrument over.
- Press the locking tab and lift off the battery compartment cover.

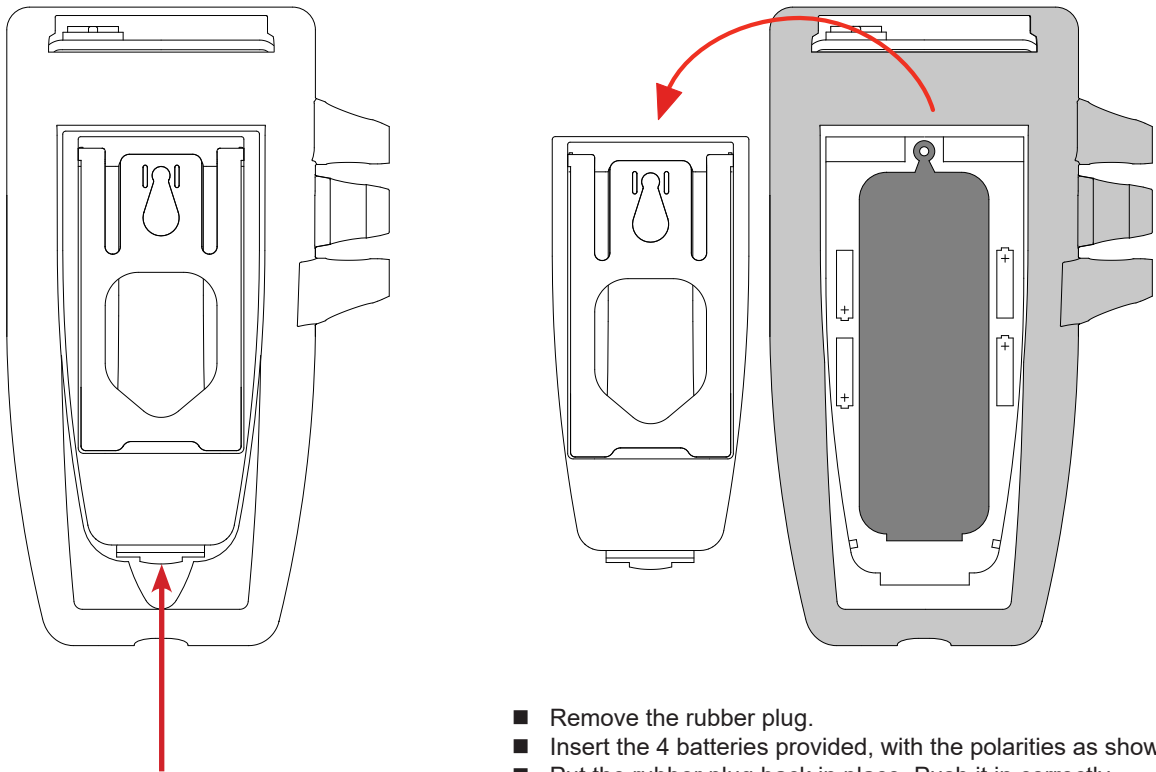

- Remove the rubber plug.
- Insert the 4 batteries provided, with the polarities as shown.
- Put the rubber plug back in place. Push it in correctly.
- Place the two front ends before pushing in the central part.
- Put the battery compartment cover back in place; make sure that it is completely and correctly closed.

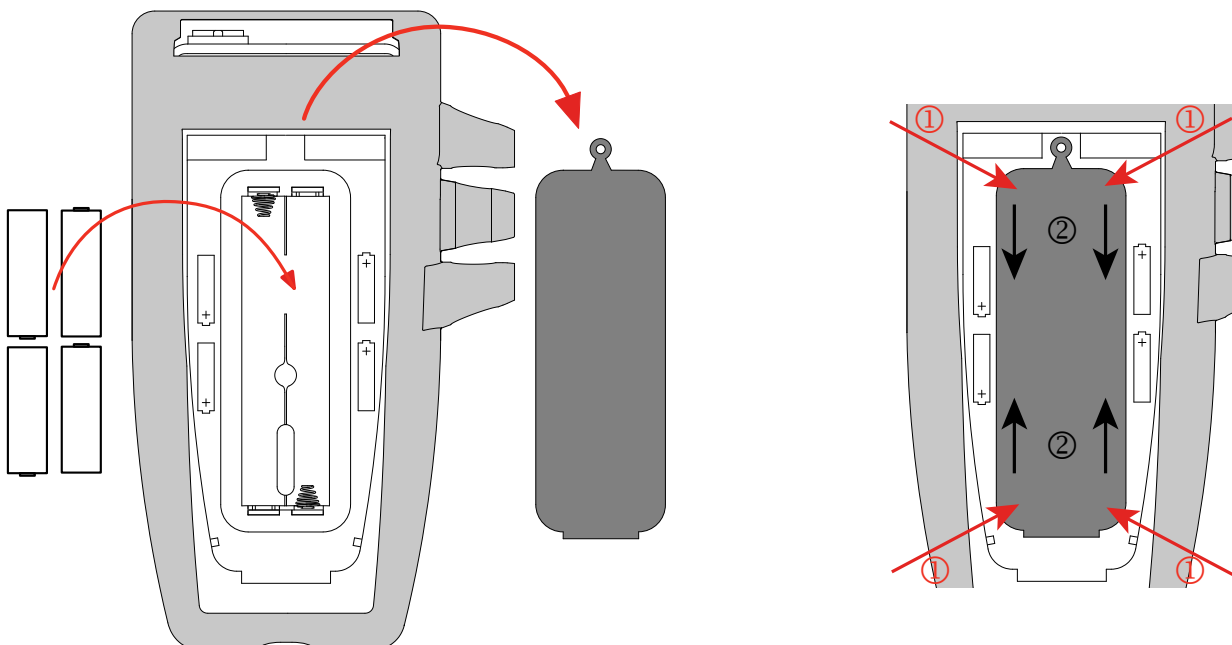

2. PRESENTATION OF THE INSTRUMENT

2.1. C.A 10141

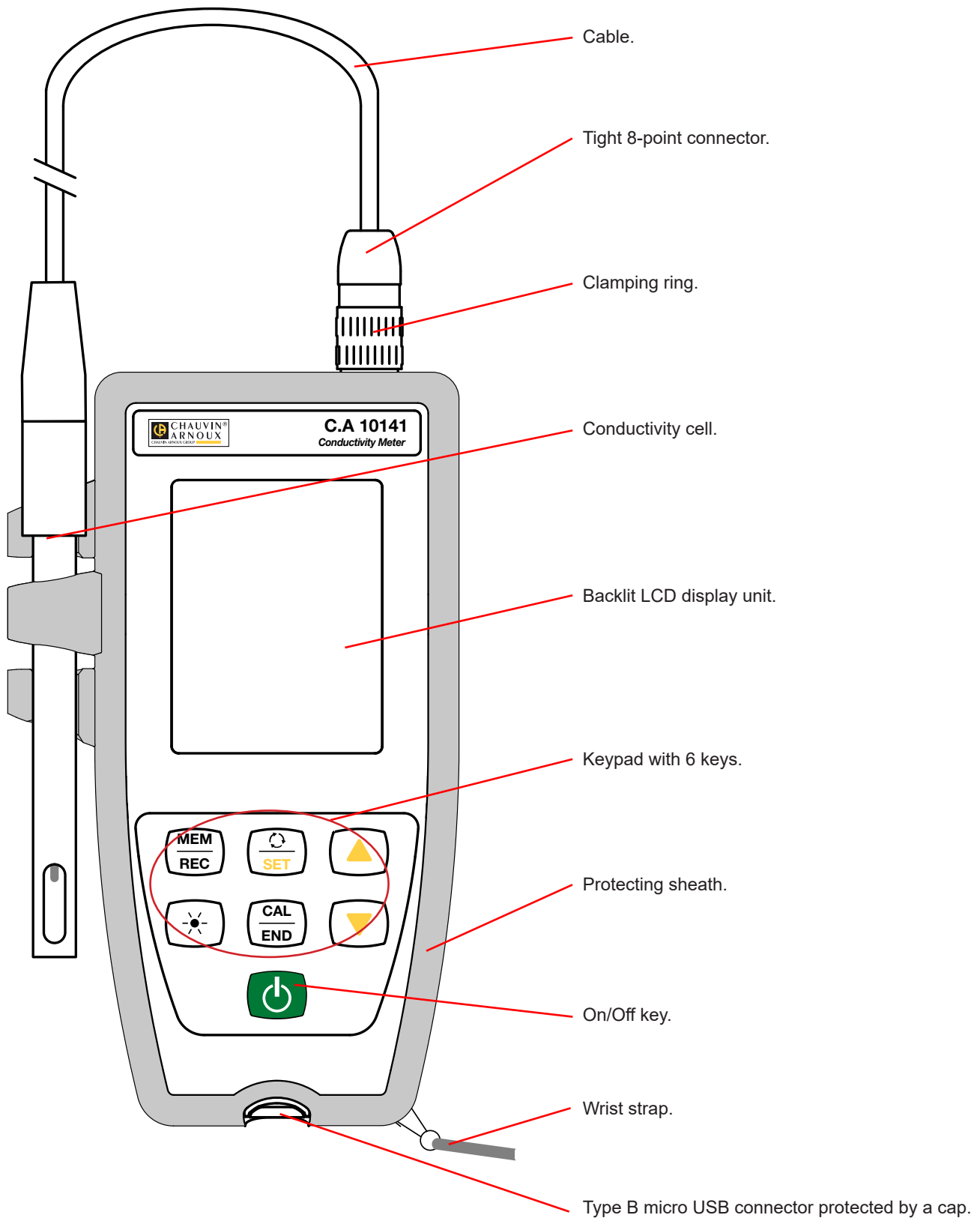

2.2. FUNCTIONS OF THE INSTRUMENT

The C.A 10141 is a conductivity meter in a watertight housing. It is used to measure conductivity, resistivity, TDS (total dissolved solids), salinity, and temperature.

This instrument is easy to use. It has extensive stand-alone capabilities and can be used:

- to calibrate the cell using a standard solution,
- to display temperature measurements in °C or in °F,
- to display the time,
- to record the measurements,
- to communicate with a PC via a USB cable.













The Data Logger Transfer software can be installed on a PC and is used to configure the instruments, to program a recording session and to recover the recorded measurements.

2.3. KEYPAD

The functions indicated above the line on the keys are accessed by a short press.

The functions indicated below the line are accessed by a long press.

To prevent inadvertently switching the instrument on, the On/Off  key requires a long press.

Key	Function
	<ul style="list-style-type: none"> ■ A long press on the  key switches the instrument on. ■ A second long press on the  key switches the instrument off when it is on. The instrument cannot be switched off while it is recording.
<u>MEM</u> REC	<ul style="list-style-type: none"> ■ A short press on the MEM key records the measurement and the temperature. ■ A long press on the REC key starts or stops a manual recording session.
 SET	<ul style="list-style-type: none"> ■ A short press on the  key is used to choose the quantity to be displayed: conductivity, resistivity, TDS, or salinity. ■ A long press on the SET key lets you view and modify the calculation parameters: <ul style="list-style-type: none"> ■ the temperature unit (°C or °F), ■ the temperature correction, ■ the reference temperature for the conductivity display (20 or 25°C), ■ the TDS (Total Dissolved Solids) factor. <p>A second long press is used to return to measurement mode.</p>
	A short press on the  key toggles the backlighting on or off. Once on, it goes off at the end of 30 seconds.
<u>CAL</u> END	<ul style="list-style-type: none"> ■ A short press on the CAL key is used to look up the current calibration and start the calibration procedure for the cell connected. ■ A long press on the END key is used to terminate the calibration procedure in progress.
 	<ul style="list-style-type: none"> ■ A short press on the  or  key is used to set the temperature in manual mode or choose the parameter to be modified in SET mode. ■ During the calibration, a long press on the  or  key is used to select the standard solution.

2.4. DISPLAY

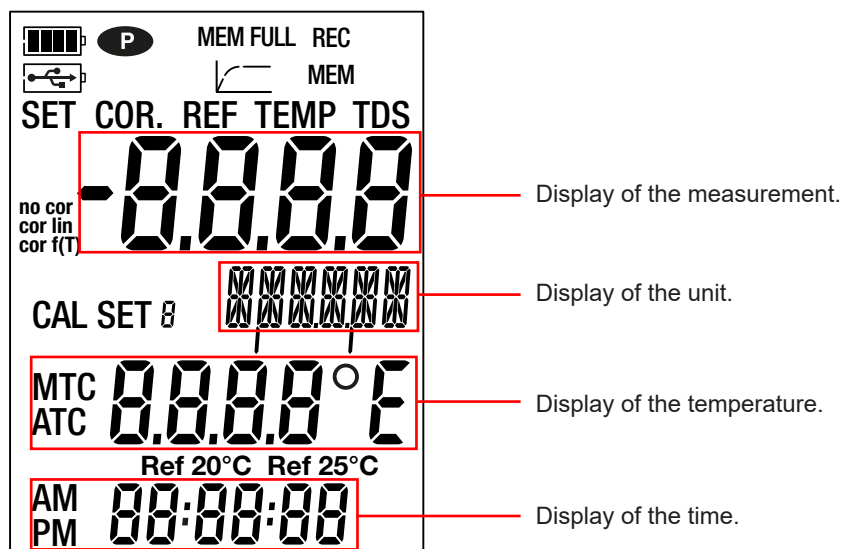

	Indicates the battery voltage level. When the symbol is empty, the batteries must be replaced.
	Indicates that the instrument is connected to a PC via the USB (cable) or that the power adapter is connected.
	Indicates that auto-off is disabled and the instrument is in permanent mode. This occurs when: <ul style="list-style-type: none"> ■ parameterizing of the instrument is in progress, ■ a calibration is in progress, ■ a recording is in progress, ■ the instrument is connected via the USB cable, ■ auto off is deactivated (see § 4.4.3).
MEM FULL	When lit steadily, indicates that the instrument's memory is full. When blinking, indicates that the instrument's memory is 90% full.
	Indicates the progress of the measurement. When all segments are lit, the measurement is stable. When blinking, indicates that the measurement is over or that the calibration has been applied.
REC	When lit steadily, indicates that recording is in progress. When blinking, indicates waiting for the start of a recording session.
MEM	Indicates that a measurement is recorded.
SET COR.	Indicates adjustment of the temperature correction.
SET REF	Indicates the reference temperature selected, 20 or 25°C (68 or 77°F)
SET TEMP	Indicates the temperature measurement unit selected.
SET TDS	Indicates adjustment of the TDS factor.
no cor cor lin cor f(T)	Indicates the type of temperature correction: <ul style="list-style-type: none"> ■ no cor: no correction ■ cor lin: linear correction from 1.00 to 7.40%/°C. ■ cor f(T): nonlinear correction, exceeding 7.40%/°C
CAL SET	Indicates that calibration is in progress.
MTC	Indicates that temperature compensation is manual.
ATC	Indicates that temperature compensation is automatic.
Ref 20°C Ref 25°C	Indicates the reference temperature, 20 or 25°C (68 or 77°F)

When the measurement exceeds the limits (whether positive or negative), the instrument displays **OL**.

2.5. SETTING THE TIME

The time of your instrument is set using the Data Logger Transfer software. Refer to §4.4.2

2.6. PROP

To make reading easier, the instrument can be set on its prop.

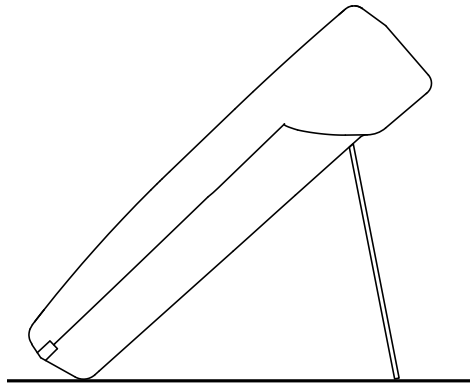

3. USE IN STAND-ALONE MODE

- The instrument can operate in two modes:
- the stand-alone mode described in this section,
- the record mode, in which it is controlled by a PC. This mode is described in the next section.



To ensure proper operation of the instrument, always leave the cell connected and the cap on the USB connector.

3.1. CONNECTING THE CELL

When you first use the instrument, connect the conductivity cell provided to the measuring instrument. Connect the connector of the cell to the instrument and screw the ring all the way on.

3.2. CALIBRATION

3.2.1. PARAMETERIZING THE MEASUREMENTS

Before calibrating the cell, you can set various parameters.

- The unit of temperature (°C or °F)
- The reference temperature, 20 or 25°C (68 or 77°F). This is the temperature to which the measurement will be referred.
- The temperature correction used to correct and display the measured conductivity as of the chosen reference temperature. This is useful because the conductivity of a solution increases with increasing temperature.

- **cor lin**: linear temperature correction

The measured conductivity is corrected and displayed using the following formula:

$$\Sigma_{\text{displayed}} = \sigma_T / (1 + \alpha (T - T_{\text{ref}}) / 100\%)$$

where: $\sigma_{\text{displayed}}$ = the conductivity displayed by the instrument.

σ_T = the conductivity measured at temperature T.

α = the linear temperature correction coefficient.

T = the measured temperature (°C)

T_{ref} = the reference temperature (20 or 25°C)

- Acids: 1 to 1.6%/°C
- Bases: 1.8 to 2.2%/°C
- Salts: 2.2 to 3.0%/°C
- Drinking water: 2.0%/°C
- Ultra-pure water: 5.2%/°C
- **no cor**: no correction, $\alpha = 0\%/^{\circ}\text{C}$.
- **cor f(T)**: nonlinear temperature correction. See appendix 1 in §8.
- TDS factor (f): between 0.40 and 1.00. This is used to calculate TDS (Total Dissolved Solids). It is expressed in mg/l or in ppm.
TDS = $\sigma \cdot f$

Where: σ = conductivity on $\mu\text{S}/\text{cm}$

f = TDS factor

- Long-press the **SET** key.

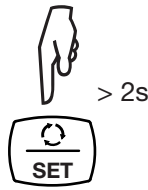

- Choose the temperature unit (°C or °F) using the ▲ and ▼ keys.

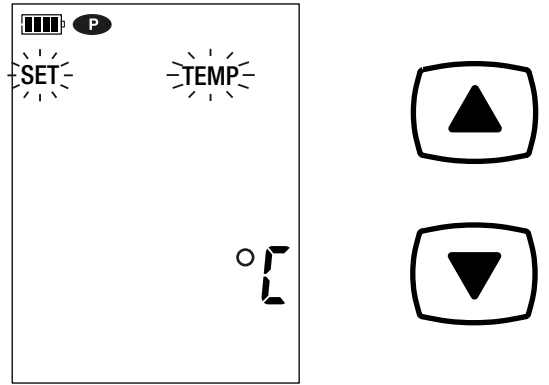

- Press the **SET** key and use the ▲ and ▼ keys to set the temperature correction.

A long press scrolls the values faster.

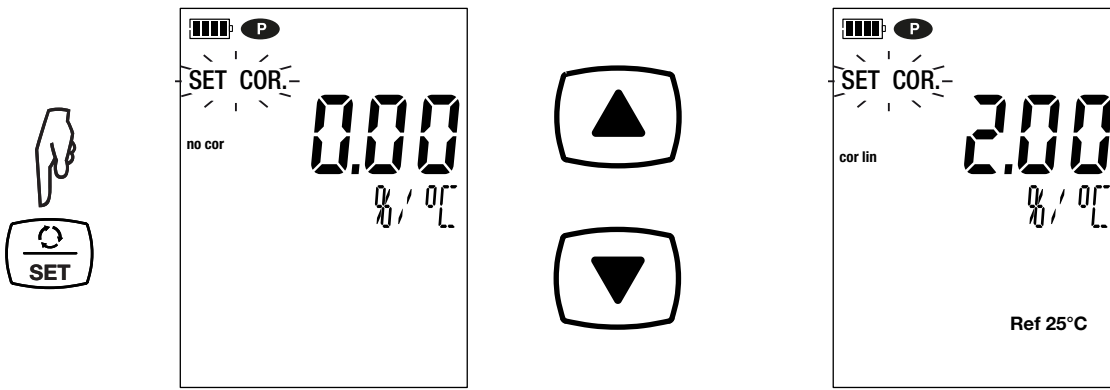

- Press the **SET** key and choose the reference temperature (20 or 25°C) using the ▲ and ▼ keys.

- Press the **SET** key and set the TDS factor (f) to between 0.40 and 1.00 using the ▲ and ▼ keys. A sustained press on ▲ or ▼ scrolls through the values faster.

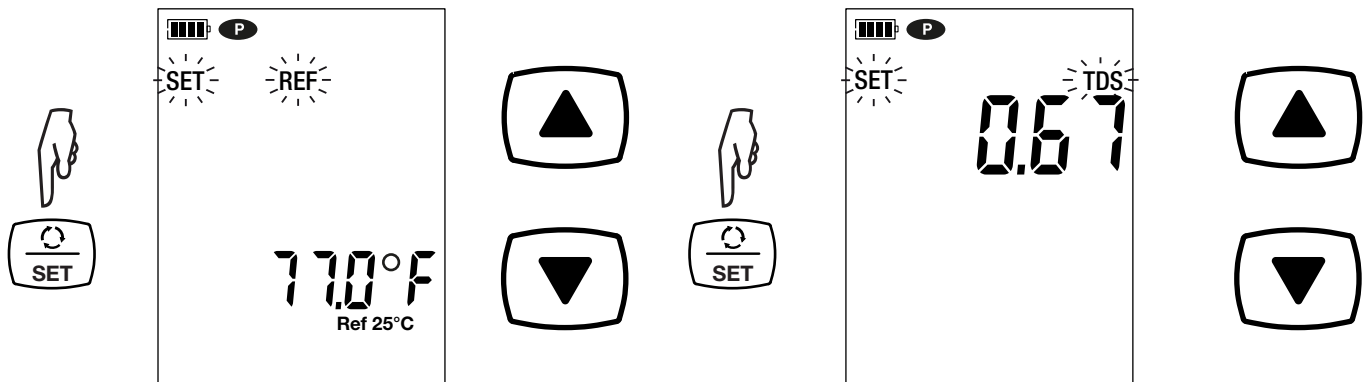

- Long-press the **SET** key to exit from parameterizing the measurements. A short press on the SET key takes you back to the choice of temperature unit.

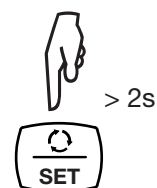

3.2.2. CHOICE OF STANDARD SOLUTION

The C.A 10141 is calibrated for conductivity.

The calibration is done at one point. Choose the solution that lies in the range of interest to you.

	Conductivity at 25°C		
Conductivity	147 $\mu\text{S/cm}$	1408 $\mu\text{S/cm}$	12.85 mS/cm
Resistivity	6.8 k $\Omega\cdot\text{cm}$	710 $\Omega\cdot\text{cm}$	77.8 $\Omega\cdot\text{cm}$
TDS	73,5 mg/l TDS factor = 0,5	746 mg/l TDS factor = 0,53	7,45 g/l TDS factor = 0,58
Salinity	-	-	7,4 psu

- Rinse the cell in deionized water, then dry it.

- Pour the standard solution into a beaker.
- Long-press the  key to switch the instrument on.

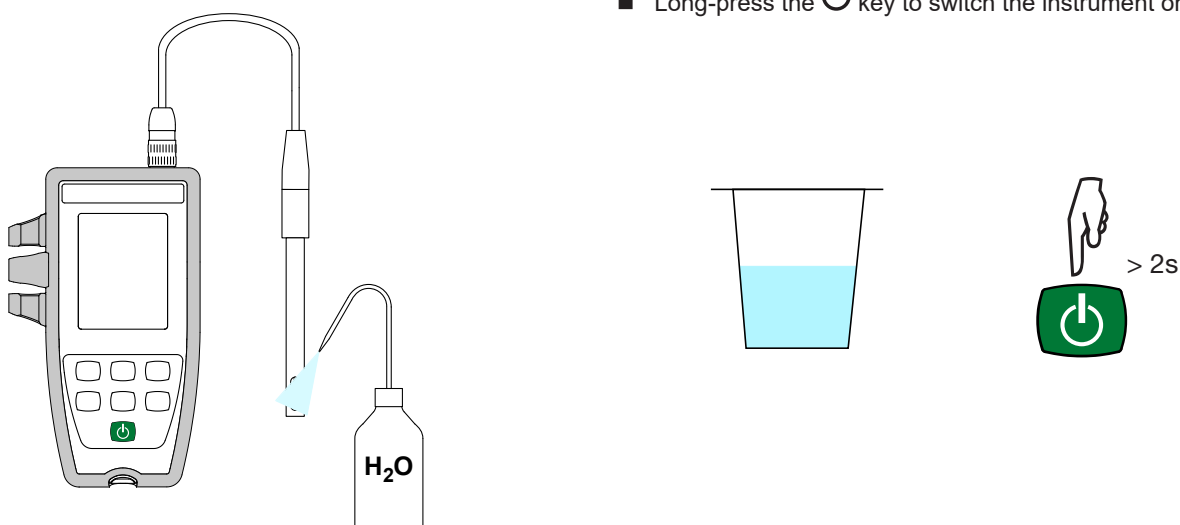

- Immerse the end of the cell in the standard solution.



Take care to completely immerse the sensitive part of the cell in the solution.

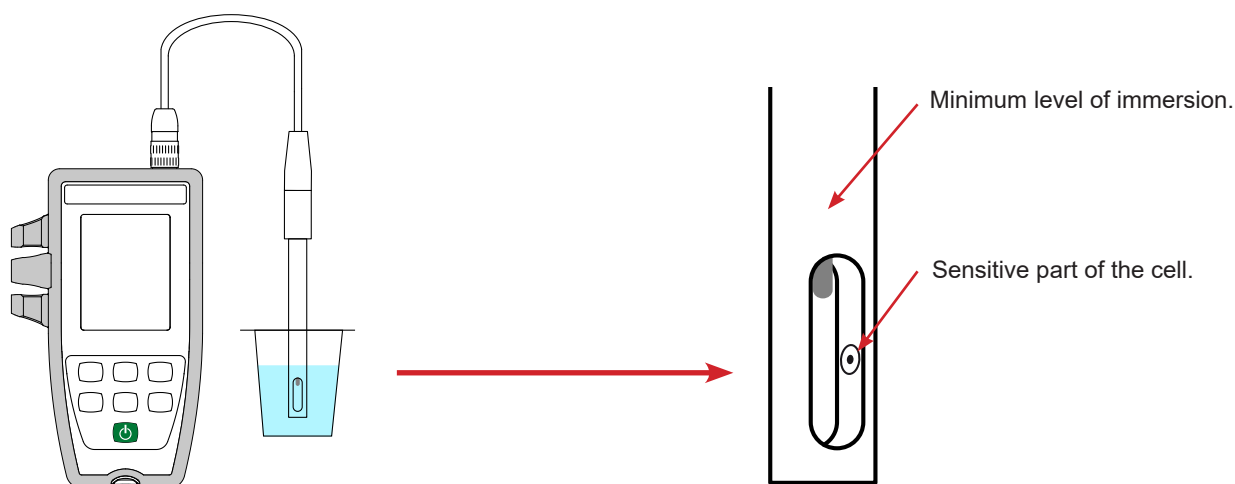

The cell provided with the instrument has an integrated temperature sensor. There is therefore no need to measure the temperature of the solution.

The instrument displays the conductivity measurement along with the measured temperature, the reference temperature, and the time.
 ATC = Automatic Temperature Compensation.

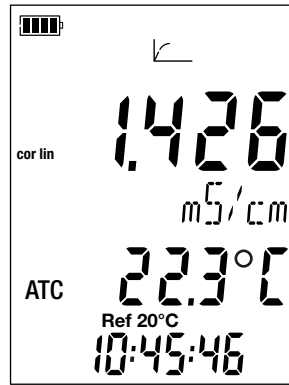

3.2.3. CALIBRATION PROCEDURE

Calibration serves to determine the constant of the conductivity cell.



In order to avoid the influence of the temperature, do the calibration at the temperature at which you will be making measurements.

- With the instrument set to conductivity measurement, press the **CAL** key.
 The instrument briefly displays the current calibration (the coefficient of the cell in cm-1).

It then prompts you to choose the calibration set.

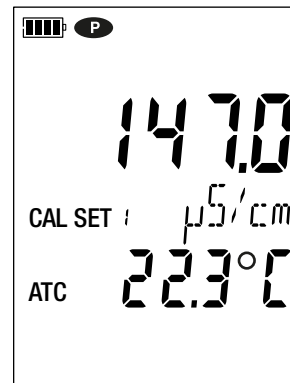

There are six sets available, corresponding to the six international standard conductivity solutions.

	Conductivity at 25°C
Calibration set 1	147.0 μS/cm
Calibration set 2	1.408 mS/cm
Calibration set 3	12.85 mS/cm
Calibration set 4	84.0 μS/cm
Calibration set 5	1.413 mS/cm
Calibration set 6	12.88 mS/cm

You can modify these values in the Set.csv file (see § 4.3).

- Choose the calibration set by long presses on the ▲ and ▼ keys.

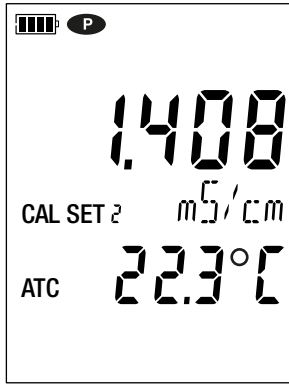
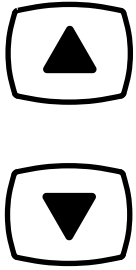

- Confirm the set by pressing the **CAL** key. The instrument displays the measured conductivity and the temperature.

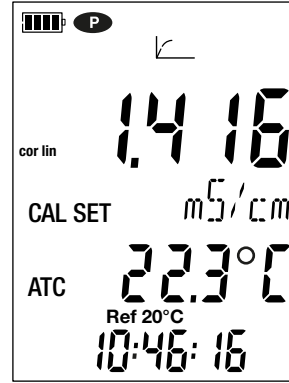

It performs the conductivity measurement and indicates its progress.



Do not withdraw the cell from the solution until the measurement is over.

To abort the calibration of the cell, long-press the **END** key before the end of the measurement.

Otherwise, when the measurement is over, the new calibration is applied.

- Press the **CAL** key. The instrument exits from the calibration procedure and briefly displays the cell coefficient before changing back to measurement mode.

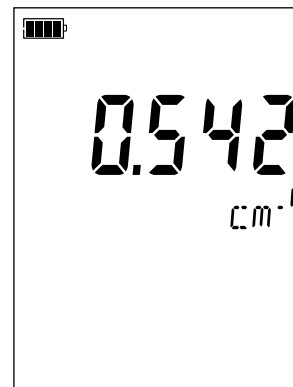

During the calibrations, the cell coefficient for a given cell must vary only a little. If you observe a large variation, it may be necessary to redo the calibration, check the condition of the standard solution (in particular the use-by date), or replace the cell.

3.2.4. RESTORE THE INITIAL CALIBRATION

Press the **CAL** key, then the **MEM** key.

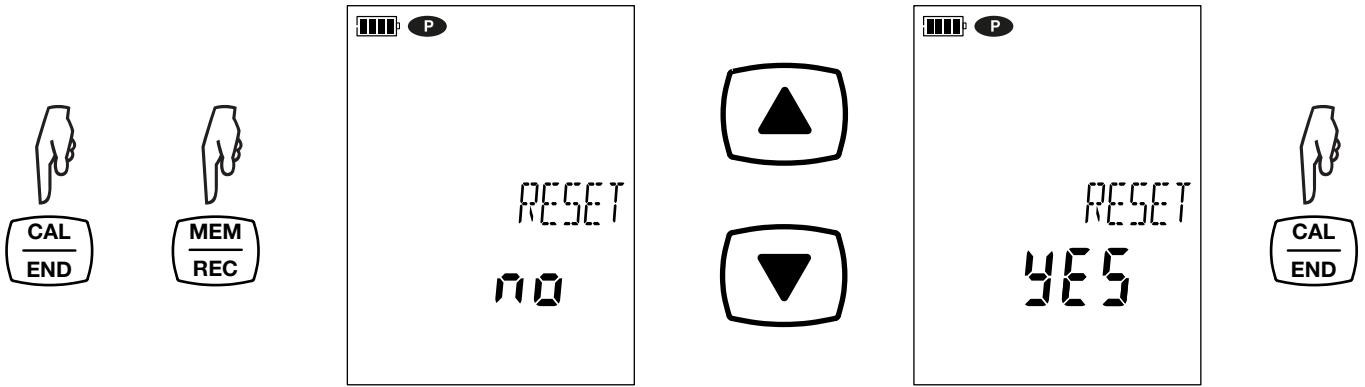

If you do not want to restore the initial calibration, choose **no** before pressing the **CAL** key.

Otherwise, choose **YES** and press the **CAL** key. The cell coefficient returns to 1.000.

3.3. CONDUCTIVITY MEASUREMENT

When the calibration is over, the cell is ready to make measurements.

i Use a cell suited to the medium to be measured.

i Between measurements, the cell must be rinsed, then dried.

i For each measurement, wait for the measurement to stabilize and for the temperature to be correctly established.

Conductivity is the capacity of a solution to conduct electric current. It is ions that carry the charges. The more ions the solution contains, the more current it will conduct.

- Immerse the end of the cell in the solution, making sure that the sensitive part is completely immersed in the solution.

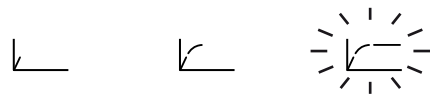
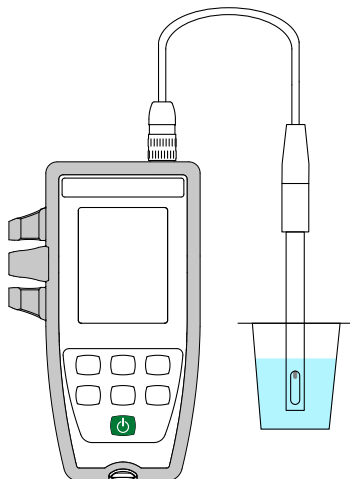

The instrument displays the measurement at the chosen reference temperature (20 or 25°C). Wait for it to stabilize before reading it on the instrument's display unit.

3.3.1. USING ANOTHER CONDUCTIVITY CELL

The cell provided with the instrument has an integrated temperature probe. If you use another cell, one without an integrated temperature sensor, you must measure the temperature of the solution.

 Use a four-pole cell suited to the medium to be measured.

The instrument indicates that the temperature can be modified by displaying **MTC** next to the temperature
MTC = Manual Temperature Compensation.

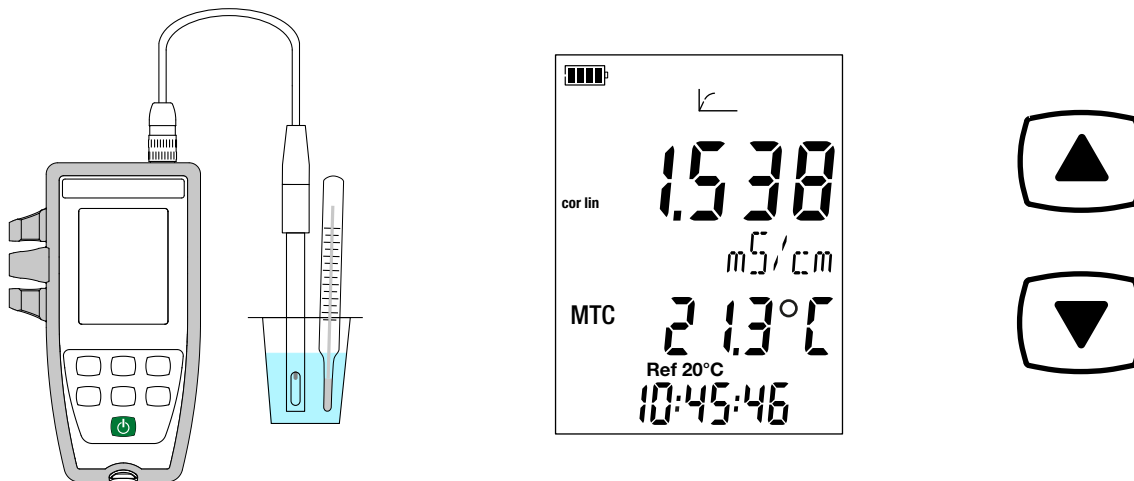

You must then correct the temperature displayed, using the ▲ and ▼ keys, so that it is equal to the measured temperature of the solution.

The instrument corrects the response of the cell as a function of the temperature.

 To calibrate the cell, always correct the temperature first.



To connect your cell, use an optional connection kit (see §1.2). These adapters also let you connect a PT1000 probe.

3.4. RESISTIVITY MEASUREMENT

Resistivity is the reciprocal of conductivity.



You must first calibrate the cell for conductivity and parameterize the measurements (in particular the temperature correction and the reference temperature) before making resistivity measurements.

- Long-press the  key to switch the instrument on.
- Press the  key to switch to resistivity measurement.

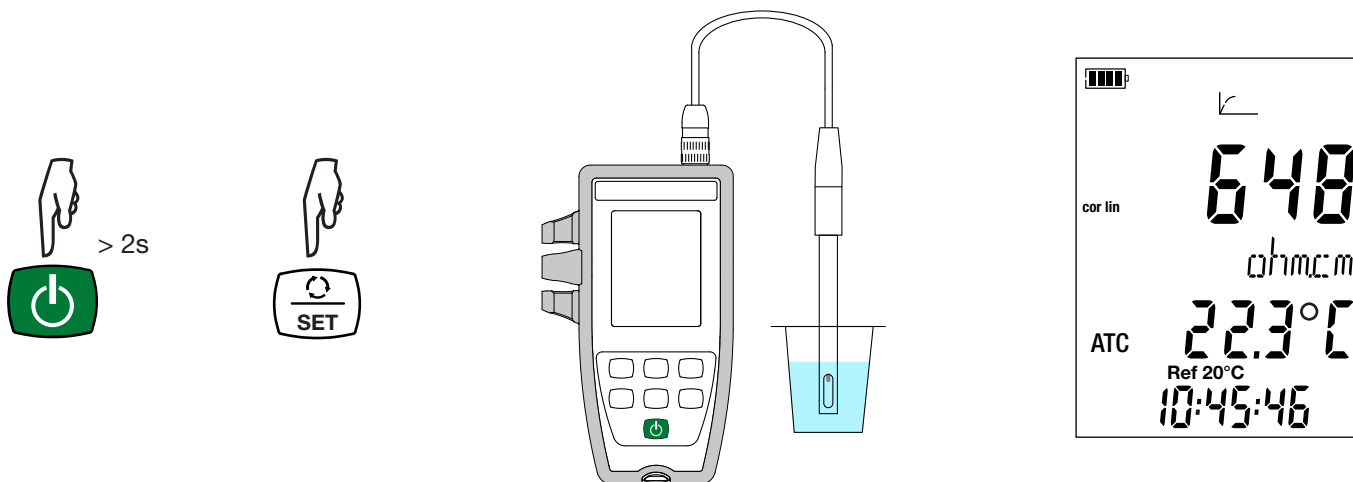



- Immerse the cell, after it has been rinsed and dried, in the solution to be measured.
- The instrument displays the measurement at the chosen reference temperature (20 or 25°C). Wait for it to stabilize to read it on the instrument's display unit.

The resistivity ranges from $2\Omega\cdot\text{cm}$ ($\sigma = 500\text{mS/cm}$) for a conducting solution to $18\text{m}\Omega\cdot\text{cm}$ ($\sigma = 55\text{nS/cm}$) for pure water.

3.5. TDS MEASUREMENT

The TDS (Total Dissolved Solids) measurement is used to estimate the level of dissolved solids in a solution.

i You must first calibrate the cell for conductivity and parameterize the measurements (in particular the temperature correction, the reference temperature, and the TDS factor) before making TDS measurements.

- Long-press the  key to switch the instrument on.
- Press the  key twice to switch to TDS measurement.

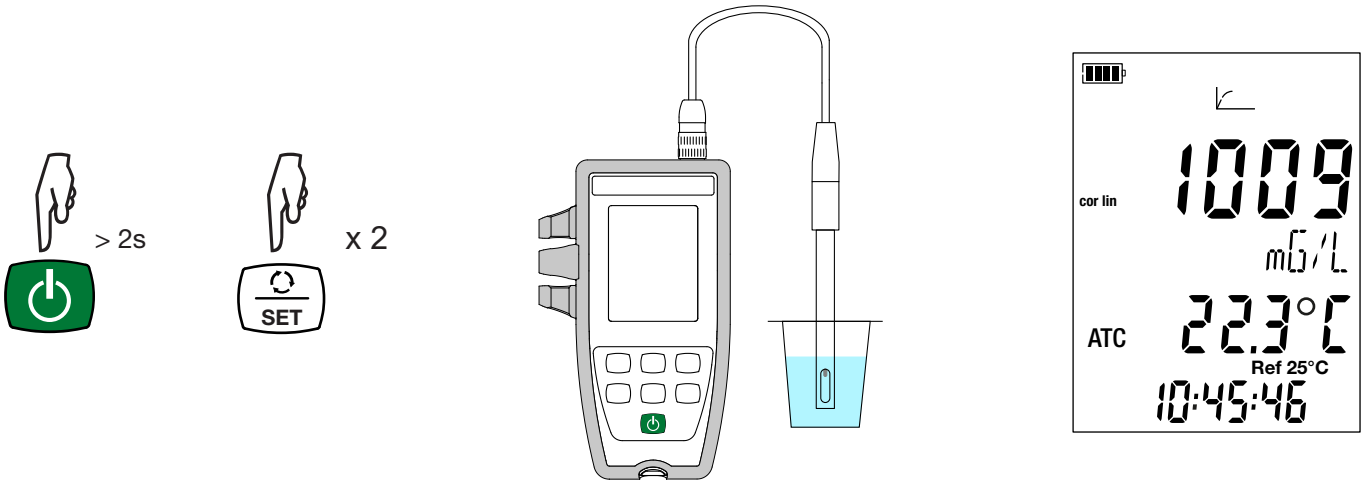



- Immerse the cell, after it has been rinsed and dried, in the solution to be measured.
- The instrument displays the measurement at the chosen reference temperature (20 or 25°C). Wait for it to stabilize to read it on the instrument's display unit.

3.6. SALINITY MEASUREMENT

The salinity measurement serves to evaluate the salt content of seawater. It is expressed in PSU (Practical Salinity Units).

The conversion from conductivity to salinity is done using the UNESCO formula (PSS-78), for a temperature of the solution ranging from -2 to +35°C. Outside of this temperature range, the instrument displays **O.L.** The conductivity displayed is referred to 15°C.

i You must first calibrate the cell for conductivity and parameterize the measurements (in particular the temperature correction and the reference temperature) before making salinity measurements.

- Long-press the  key to switch the instrument on.
- Press the  key three times to switch to salinity measurement.

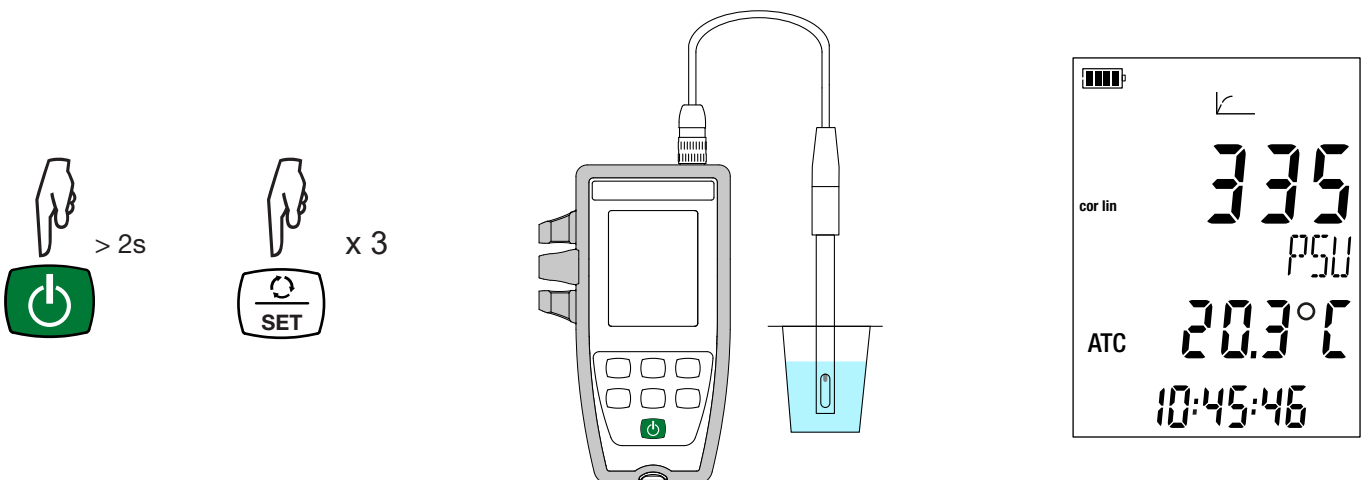

3.7. RECORDING THE MEASUREMENTS

- A short press on the **MEM** key records the measurement with the date and time. The **MEM** symbol is displayed briefly. It is not possible to record a single/~~an isolated~~ measurement ~~when~~ while the instrument is ~~(already?)~~ recording.
- A long press on the **REC** key starts or stops a recording session. The **REC** symbol remains displayed for the duration of a recording session. Auto off is deactivated (this means that the instrument is in permanent mode) and the **P** symbol is displayed.



Before starting a recording session, make sure that the battery life is sufficient, or else connect the instrument to an external power supply on/to a wall outlet using a micro USB cord.

When the memory is 90% full, the **MEM FULL** symbol blinks. When the memory is full, the **MEM FULL** symbol stops blinking-

To see the records, you must use a PC and install the Data Logger Transfer software (see §4).

3.8. ERRORS

The instrument detects errors and displays them in the form Er.XX. The main errors are the following:

- Er.01: Hardware malfunction detected. The instrument must be sent in for repair.
- Er.02: Error in internal memory. Format it using Windows.
- Er.03: The update of the internal software is not compatible with the instrument (the software is that of another instrument of the line). Install the correct internal software in your instrument.
- Er.10: The instrument has not been calibrated or the calibration is not in conformity. The instrument must be sent back to customer service.
- Er.12: The update of the internal software is not compatible with the electronic boards in the instrument. Reload the previous internal software into your instrument.
- Er.13: Recording scheduling error. Check that the instrument's time and the time of the Data Logger Transfer software are the same.
- Er.14: Calibration error. The measured value is too far from the value of the standard solution of the selected calibration set. Check that the solution used in fact belongs to the selected set. If necessary, return to the initial calibration (see § 3.2.4).
- Er.15: Calibration error. The stabilization time is too long.
- Er.19: Calibration error. The temperature (ATC or MTC) is outside of the specifications of the standard solutions. Redo the calibration in a room where the temperature lies within the specifications of the standard solution (see the Set.csv file, §4.3).
- Er.20: Calibration error. The file defining the set of calibration solutions is missing. Download it from our web site: www.chauvin-arnoux.com
- Er.21: Calibration error. The file defining the set of calibration solutions is not in conformity. Check that it is the right file. If you have modified it, check the format; in particular, the decimal separators must be points, not commas.
- Er.22: Recording error. Power was cut off while recording was in progress.
- Er.50: Calibration error. Measurement error for the calibration.

To exit from calibration errors, press the **CAL** key or the **END** key.

4. USE IN RECORDING MODE

The instrument can operate in two modes:

- the stand-alone mode described in the previous section,
- the record mode, in which it is controlled by a PC. This mode is described below.

4.1. CONNECTION

The instrument communicates by a USB link, using the USB to micro USB cord provided.

4.2. GET DATA LOGGER TRANSFER SOFTWARE

Visit our web site to download the latest version of the application software:

www.chauvin-arnoux.com

Go to the **Support** tab, then **Download our software**. Then search on the name of your instrument.

Download the software, then install it on your PC.



You must have administrator privileges on your PC to install the Data Logger Transfer software.

Minimum computer requirements:

Windows 7 (32/64 bits)

2 GB of RAM

200 MB of disc space

Windows® is a registered trade mark of Microsoft®.



Do not connect the instrument to the PC until you have installed the Data Logger Transfer software.

4.3. USB LINK

Long-press the  key to switch the instrument on.

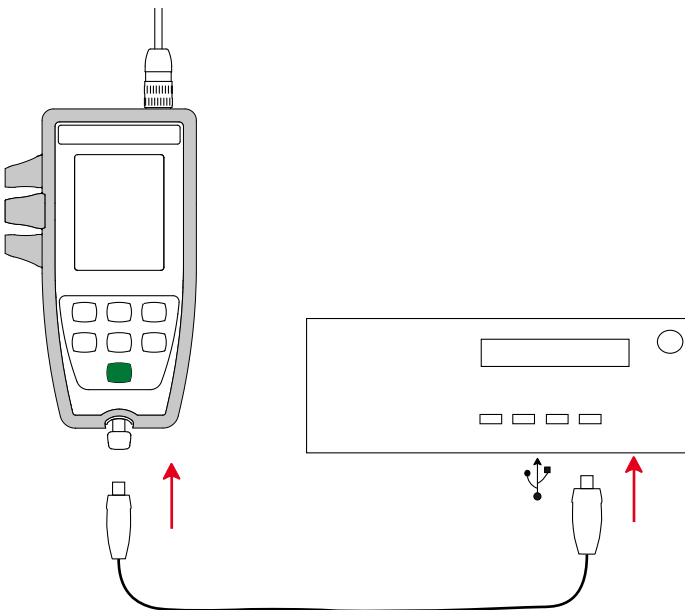

Once the Data Logger Transfer software has been installed, connect the instrument to the PC.

The  symbol blinks.

The instrument is treated as a USB key and you can access its contents. But to read the records, you must use the Data Logger Transfer software.

This content includes the Set.csv file. You can open this file in a spreadsheet and modify it:

- add or remove a calibration set
- modify a calibration set by adding, removing, or modifying standard solutions.



Do not change the structure of the file.

	A	B	C	D
1	SET NUMBER		6	
2	SOLUTION SET		1	
3	SOLUTION NUMBER		1	
4	BUFFER	Conductivity	0.147	
5		TEMPERATURE [°C]	Conductivity	
6		15	0.119	
7		20	0.133	
8		25	0.147	
9		30	0.161	
10		35	0.177	
11	SOLUTION SET		2	
12	SOLUTION NUMBER		1	
13	BUFFER	Conductivity	1.408	
14		TEMPERATURE [°C]	Conductivity	
15		15	1.1142	
16		20	1.220	
17		25	1.408	
18		30	1.547	
19		35	1.688	
20	SOLUTION SET		3	
21	SOLUTION NUMBER		1	
22	BUFFER	Conductivity	12.85	
23		TEMPERATURE [°C]	Conductivity	
24		15	10.46	
25		20	11.64	
26		25	12.85	
27		30	14.09	
28		35	15.35	
29	SOLUTION SET		4	
30	SOLUTION NUMBER		1	
31	BUFFER	Conductivity	0.084	
32		TEMPERATURE [°C]	Conductivity	
33		0	0.046	
34		10	0.06	
35		15	0.068	
36		20	0.076	

Number of calibration sets.

Calibration set number (1, 2, 3, etc.).

Conductivity of the standard solutions in mS/cm.

Evolution of the conductivity of the standard solution as a function of temperature.

4.4. DATA LOGGER TRANSFER SOFTWARE

Once the instrument is connected to the PC, open the Data Logger Transfer software.



For context-sensitive information about the use of the Data Logger Transfer software, refer to the **Help** menu.

4.4.1. CONNECTING THE INSTRUMENT

- To connect an instrument, click **Add an instrument**, then choose the type of connection (USB).
- A window opens with a list of all instruments connected to the PC.
The name of the instrument will be formed from the model of the instrument and the warranty number: CA10141 - 123456ABC.
You can personalize your instrument by adding a name and a location, by clicking on or .
- Choose your instrument in the list. The instrument then displays complete information about the instrument and its measurements in progress.

The screenshot shows the Data Logger Transfer software interface. The main window is titled "Data Logger Transfer" and has a menu bar with "File", "Edit", "View", "Instrument", "Tools", and "Help". Below the menu bar is a toolbar with icons for "Open", "Save", "Create report", "Create DOXC", "Print", "Print Preview", "Add an instrument", "Remove an instrument", "Download Recorded Data", "Configure", and "Start Recording".

The interface is divided into two main sections. On the left is a "Workstation" tree view showing a hierarchy: "Data Logger Network" > "Conductivity-meter" > "Recorded Sessions" > "Real-time Data". Below this are "My Open Sessions".

The right section is titled "Status" and contains a table of instrument information. The table is organized into several sections:

General		Recording	
Serial number	123456ABC	Recording status	Inactive
Model	10141	Session(s)	16
Firmware version	00.64	Idle	Elapsed
Instrument name	Conductivity-meter	Starting date/time	---
		Ending date/time	---
		Duration	---
Status		Recording Storage Rate	02 s
In overload	No		
Date	22/10/2018	Channel Configuration	
Time	12:24:03	Channel 1	Temperature
Battery voltage	5,33 V	Units:	°C
Communication		Channel 2	Electrical Conductivity
Connection Type	USB	Units:	S/cm
Connection status	Communicating	Sensor calibration	
Memory		Last calibration date	03/01/2018
Memory capacity	7,96 MBytes	Cell constant	1,98
Memory used	416,00 kBytes	Solution, conductivity	0,01 S/cm
		Solution, temperature	23,0 °C

4.4.2. DATE AND HOUR

In the **Instrument** menu, the icon lets you set your instrument's date and time. These cannot be changed while recording or when a recording session has been scheduled. By clicking , you can choose the date and time display formats.

4.4.3. AUTO OFF

As default, the instrument switches itself off automatically after 5 minutes of operation without the user's presence being confirmed by a key-press. By clicking , you can change this value to 3, 10, or 15 minutes.

It is also possible to disable this auto-off function; the instrument then displays the symbol.

4.4.4. PROGRAMMED RECORDING SESSIONS

By clicking , you can program a recording session. Assign a name to the recording session. Then enter a starting date and time and an ending date and time or a duration. The maximum duration of a recording session depends on the memory available.

Choose a sampling period. The possible values are: 1 s, 2 s, 5 s, 10 s, 20 s, 30 s, 1 min, 2 min, 5 min, 10 min, 15 min, 30 min and 1 hour. The shorter the sampling period, the larger the recorded file.

Before and after the recording session, if the instrument is switched on, the sampling period will be that of the stand-alone mode (1s).

If the instrument is off when recording starts, it switches itself on by itself. Then it displays the measurement, which it refreshes at each sampling period.



Before starting a recording session, make sure that the battery life is sufficient, or else connect the instrument to an external power supply to a wall outlet using a USB cord.

4.4.5. DISPLAY

By clicking on , then going to the **Conductivity meter** tab, you can modify the quantities displayed on the instrument and the various values contained in Set-up.

4.4.6. READING THE RECORDS

The Data Logger Transfer software lets you read the records made. Click **Recorded Sessions** under the name of your instrument to obtain a list of the records.

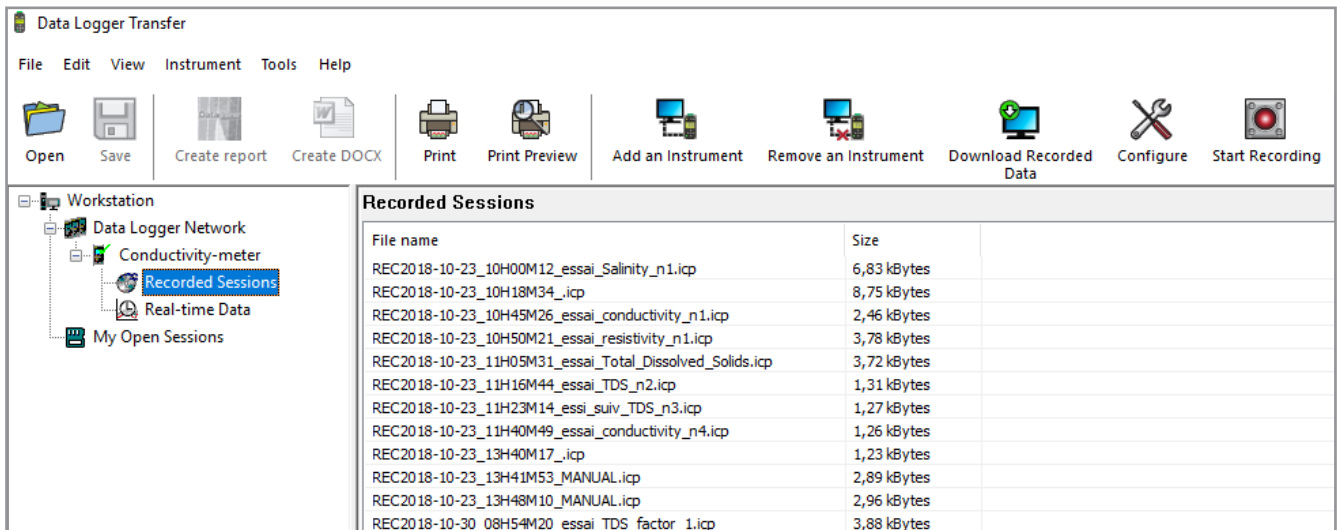

The screenshot shows the 'Data Logger Transfer' software interface. The menu bar includes File, Edit, View, Instrument, Tools, and Help. The toolbar contains icons for Open, Save, Create report, Create DOCX, Print, Print Preview, Add an Instrument, Remove an Instrument, Download Recorded Data, Configure, and Start Recording. The left sidebar shows a 'Workstation' tree with 'Data Logger Network', 'Conductivity-meter', 'Recorded Sessions' (highlighted), 'Real-time Data', and 'My Open Sessions'. The main window displays a table of recorded sessions.

File name	Size
REC2018-10-23_10H00M12_essai_Salinity_n1.icp	6,83 kBytes
REC2018-10-23_10H18M34_.icp	8,75 kBytes
REC2018-10-23_10H45M26_essai_conductivity_n1.icp	2,46 kBytes
REC2018-10-23_10H50M21_essai_resistivity_n1.icp	3,78 kBytes
REC2018-10-23_11H05M31_essai_Total_Dissolved_Solids.icp	3,72 kBytes
REC2018-10-23_11H16M44_essai_TDS_n2.icp	1,31 kBytes
REC2018-10-23_11H23M14_essai_suiv_TDS_n3.icp	1,27 kBytes
REC2018-10-23_11H40M49_essai_conductivity_n4.icp	1,26 kBytes
REC2018-10-23_13H40M17_.icp	1,23 kBytes
REC2018-10-23_13H41M53_MANUAL.icp	2,89 kBytes
REC2018-10-23_13H48M10_MANUAL.icp	2,96 kBytes
REC2018-10-30_08H54M20_essai_TDS_factor_1.icp	3,88 kBytes

4.4.7. EXPORTING RECORDS

Once the list of the records is displayed, choose the one you want to export and convert it into a word-processing document (docx) or a spreadsheet (xlsx), in order to be able to use it in the form of reports or curves.

It is also possible to export the data to the DataView application software (see § 1.2).

4.4.8. REAL-TIME MODE

Click **Real-time data** under the name of your instrument to see the measurements being made on the instrument as they are made.

4.4.9. FORMATTING THE MEMORY OF THE INSTRUMENT

The internal memory of the instrument is already formatted. But if there is a problem (if it becomes impossible to read or to write), it may be necessary to reformat it (in Windows).



In this case, all of the data will be lost.

5. TECHNICAL CHARACTERISTICS

5.1. REFERENCE CONDITIONS

Quantity of influence	Reference values
Temperature	23 ± 3 °C
Relative humidity	45% to 75%
Battery supply voltage	4 to 6.4 V
USB supply voltage	5 V ± 5%
Electric field	< 1 V/m
Magnetic field	< 40 A/m

The intrinsic uncertainty is the error specified for the reference conditions. It is expressed in % of the reading (L).

5.2. ELECTRICAL CHARACTERISTICS

The intrinsic uncertainties on the measurements are given for the instrument alone. The uncertainty of the cell used must be added to them.

5.2.1. CONDUCTIVITY MEASUREMENTS

Specified measurement range	0.050 to 4.999 µS/cm	5.00 to 49.99 µS/cm	50.0 to 499.9 µS/cm
Resolution (R)	1 nS/cm	10 nS/cm	100 nS/cm
Intrinsic uncertainty of the instrument alone without the cell (E)	± 0.5% L ± R *		

Specified measurement range	0.500 to 4.999mS/cm	5.00 to 49.99mS/cm	50.0 to 500.0mS/cm
Resolution (R)	1 µS/cm	10 µS/cm	100 µS/cm
Intrinsic uncertainty of the instrument alone without the cell (E)	± 0.5% L ± R *		

5.2.2. RESISTIVITY MEASUREMENTS

Specified measurement range	2.000 to 4.999 Ω.cm	5.00 to 49.99 Ω.cm	50.0 to 499.9 Ω.cm	500 to 4999 Ω.cm
Resolution (R)	1 mΩ.cm	10 mΩ.cm	100 mΩ.cm	1 Ω.cm
Intrinsic uncertainty of the instrument alone without the cell (E)	± 0.5% L ± R *			

Specified measurement range	5.00 to 49.99 kΩ.cm	50.0 to 499.9 kΩ.cm	500 to 4999 kΩ.cm	5.00 to 19.99mΩ.cm
Resolution (R)	10 Ω.cm	100 Ω.cm	1 kΩ.cm	10 kΩ.cm
Intrinsic uncertainty of the instrument alone without the cell (E)	± 0.5% L ± R *			

*: provided that the cell used has a coefficient:

- ≥ 1 from 2µS/cm to 499.9 mS/cm
- ≤ 0.5 from 50nS/cm to 49.99 mS/cm

5.2.3. TDS MEASUREMENTS

Specified measurement range	0.001 to 4.999 mg/l	5.00 to 49.99 mg/l	50.0 to 499.9 mg/l
Resolution (R)	1 µg/l	10 µg/l	100 µg/l
Intrinsic uncertainty of the instrument alone without the cell (E)	± 0.5% L ± R *		

Specified measurement range	500 to 4999 mg/l	5.00 to 49.99 g/l	50.0 to 499.9 g/l
Resolution (R)	1 mg/l	10 mg/l	100 mg/l
Intrinsic uncertainty of the instrument alone without the cell (E)	± 0.5% L ± R *		

5.2.4. SALINITY MEASUREMENTS

Specified measurement range: 2.0 to 42.0 PSU

Intrinsic uncertainty of the instrument alone without the cell: ± 0.5% L ± R

5.2.5. TEMPERATURE MEASUREMENTS

Temperature measurements are made with a PT1000 resistive probe built into the cell.

Specified measurement range	- 10,0 to + 120,0°C	14,0 to 248,0°F
Resolution	Display in °C: 0.1°C	Display in °F: 0.1°F
Intrinsic uncertainty of the instrument alone without the cell	< 0.4°C	< 0.7°F

5.2.6. INFLUENCE OF TEMPERATURE

Influence of temperature (from -10°C to 55°C at 50% RH) on the C.A 10141.

Type of measurement	Typical influence	Maximum influence
Conductivity measurement > 0.2 µS/cm	0.25%/10°C	0.5%/10°C
Conductivity measurement ≤ 0.2 µS/cm	0.5%/10°C	1.5%/10°C
Temperature measurement	≤ 0.2°C	

If the calibration is done at the temperature of use, then the influence of temperature is zero.

5.2.7. INFLUENCE OF HUMIDITY

Influence of humidity (from 25 to 90% RH at 25°C) on the C.A 10141.

Type of measurement	Typical influence	Maximum influence
Conductivity measurement > 0.2 µS/cm	0.25%	0.5%
Conductivity measurement ≤ 0.2 µS/cm	0.5%	1.5%
Temperature measurement	≤ 0.2°C	

5.3. MEMORY



The size of the flash memory containing the records is 8 MB.

This capacity makes it possible to record 100,000 measurements. Each measurement is recorded with the date and time.

5.4. USB

Protocol: USB Mass Storage
Maximum transmission speed: 12 Mbit/s
Type B micro-USB connector

5.5. POWER SUPPLY

The instrument is supplied by three 1.5V LR6 or AA alkaline batteries. It is possible to replace the batteries by rechargeable NiMH batteries of the same size. But the rechargeable batteries, even when correctly charged, will not reach the voltage of the alkaline batteries and the life indicated will be  or .

The voltage range ensuring correct operation is from 4.0 to 6.4 V for the alkaline batteries and 4.0 to 5.2 V for the rechargeable batteries.

Below 4V, the instrument stops making measurements and displays **BAt**.

Battery life is 300 h.

The instrument can also be powered via a USB-micro USB cord, connected either to a PC or to a wall outlet via a mains adapter. The  symbol is displayed in this case.

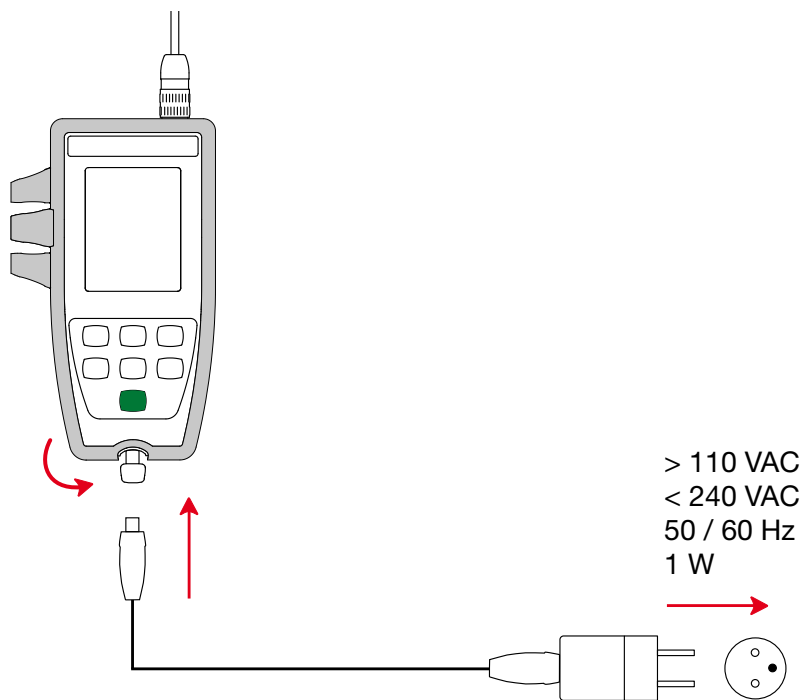

Connecting the external USB supply does not recharge the storage batteries.

5.6. ENVIRONMENTAL CONDITIONS

Instrument for indoor and outdoor use.

Altitude < 2000m, and 10,000m in storage.

Pollution degree 2

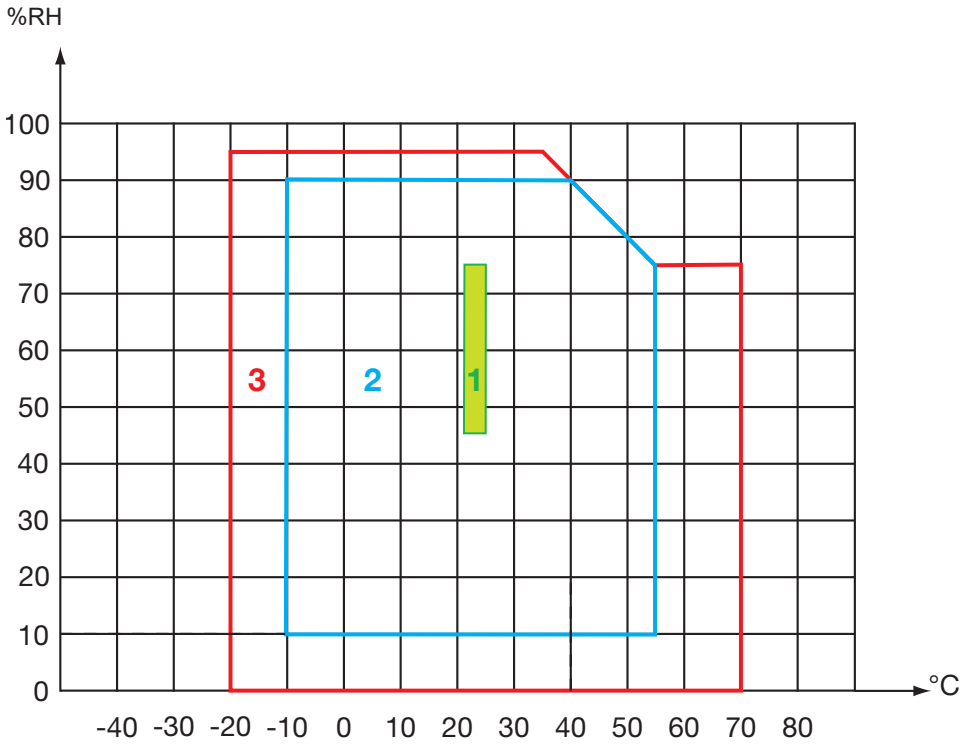

1 = Range of reference.

2 = Range of use.

3 = Range for storage (with neither primary nor rechargeable batteries. Except conductivity cell and standard solutions).

5.7. MECHANICAL CHARACTERISTICS

Dimensions (L x W x D) 211 x 127 x 54mm with the sheath

Dimensions (L x W x D) 206 x 97 x 49mm without the sheath

Mass of the instrument approximately 600g

Mass with the cell approximately 720g

Inrush protection IP 67 per IEC 60 529, with the USB connector closed and the cell connected.

IP 20 otherwise.

Drop impact test 1.50m.

5.8. COMPLIANCE WITH INTERNATIONAL STANDARDS

The instrument is compliant with standard IEC 61010-2-30.

5.9. ELECTROMAGNETIC COMPATIBILITY (CEM)

The instrument is compliant with standard IEC 61326-1.

6. MAINTENANCE



Except for the batteries, the instrument contains no parts that can be replaced by personnel who have not been specially trained and accredited. Any unauthorized repair or replacement of a part by an “equivalent” may gravely impair safety.

6.1. CLEANING

6.1.1. INSTRUMENT

Switch the instrument off.

Use a soft cloth, dampened with soapy water. Rinse with a damp cloth and dry rapidly with a dry cloth or forced air. Do not use alcohol, solvents, or hydrocarbons.

The two parts of the connector (instrument end and cell end) must remain perfectly clean and dry. This is why it is best to leave the cell connected to the instrument at all times.



If immersed, dry the instrument at the USB connector and the cell connector.

6.1.2. CELL

For the cleaning and maintenance of the cell, refer to its user manual.

6.1.3. PROTECTIVE SHEATH

- To withdraw the protective sheath, first disconnect the cell, then remove the wrist strap.
- Free the bottom of the casing from the sheath
- Then withdraw the housing from the sheath.

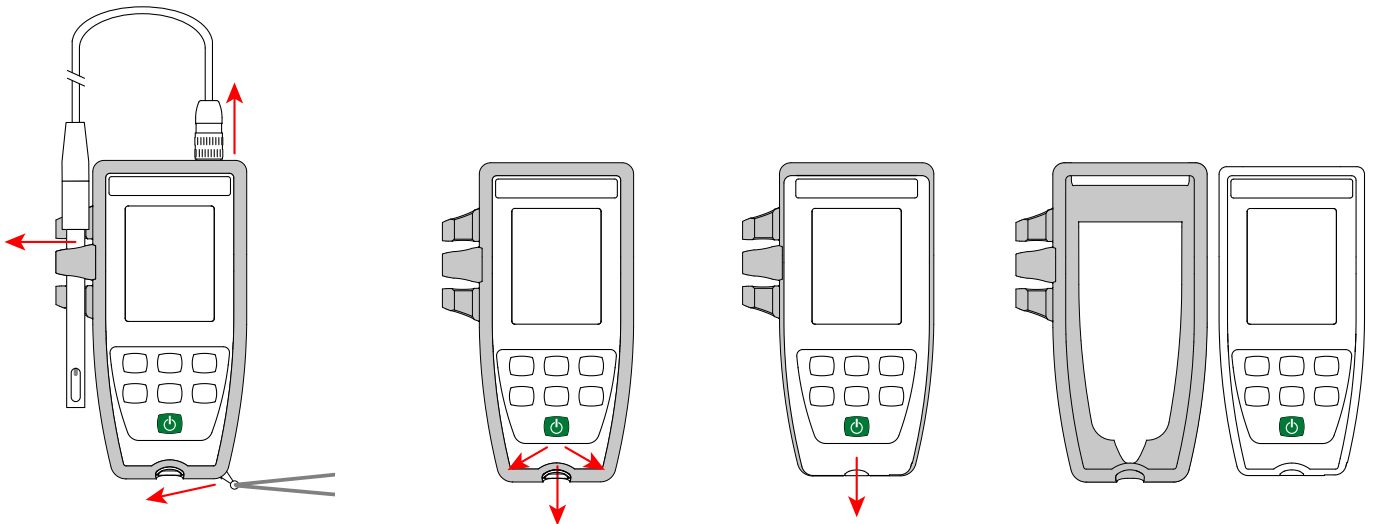

6.2. REPLACEMENT OF BATTERIES

The  symbol indicates the remaining battery life. When the  symbol is empty, all of the batteries must be replaced.

- Switch the instrument off.
- Refer to §1.4 for the replacement procedure.



Spent batteries must not be treated as ordinary household waste. Take them to the appropriate recycling collection point.



When the batteries are removed, the time is preserved for approximately two minutes.

6.3. SERIAL NUMBER

If you ever need to send your instrument in for repair, it will be helpful to know its serial number. It is found in the guarantee.txt file. This file is in your instrument's memory. To access it, simply connect the USB cord (see § 4.3).

The serial number is also marked on a label under the batteries.

6.4. CALIBRATION LOG

At each calibration, information is entered in the calib_log.txt file:

- the date and time, the coefficient of the cell on which the calibration was done.

This file is in your instrument's memory. To access it, simply connect the USB cord (see § 4.3).

6.5. EMBEDDED SOFTWARE VERSION

To look up the version number of the embedded software in your instrument, press the **MEM** and  keys simultaneously. The instrument displays the number for a few seconds, then returns to measurement mode.

6.6. UPDATING THE EMBEDDED SOFTWARE

With a view to providing, at all times, the best possible service in terms of performance and technical improvements, Chauvin Arnoux offers you the possibility of updating the internal software of this instrument by downloading, free of charge, the new version available on our web site.

See you on our site:

www.chauvin-arnoux.com

Then go to "Support", then "Download our software", then "C.A 10141".



Updating the embedded software may reset the configuration and cause the loss of the recorded data. As a precaution, save the data in memory to a PC before updating the embedded software.

Embedded software update procedure

- Download the .bin file from our web site, then press and hold the **MEM** key and switch the instrument on by pressing the  key. The instrument displays **BOOT**.

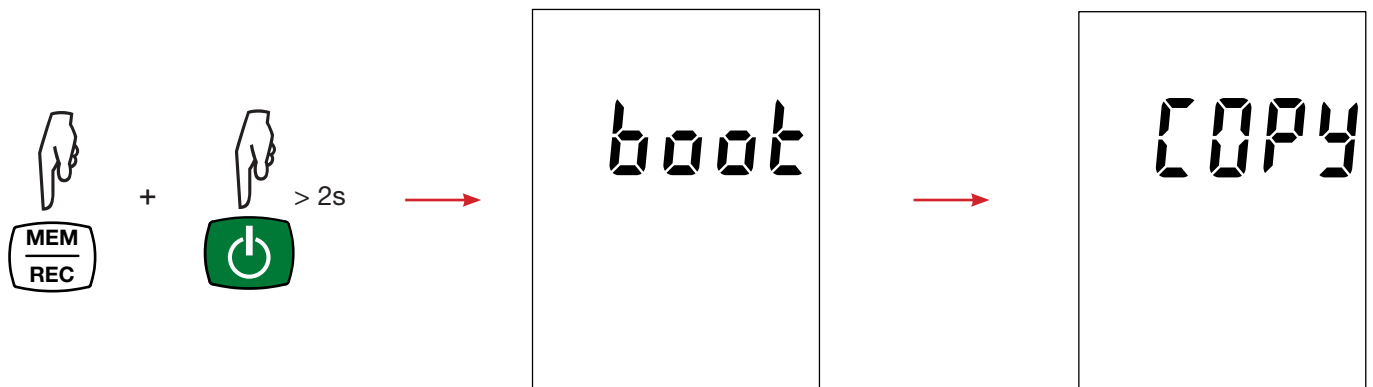

- Release the keys and the instrument displays **COPY**, indicating that it is ready to receive the new software.
- Connect the instrument to your PC using the USB cord provided.

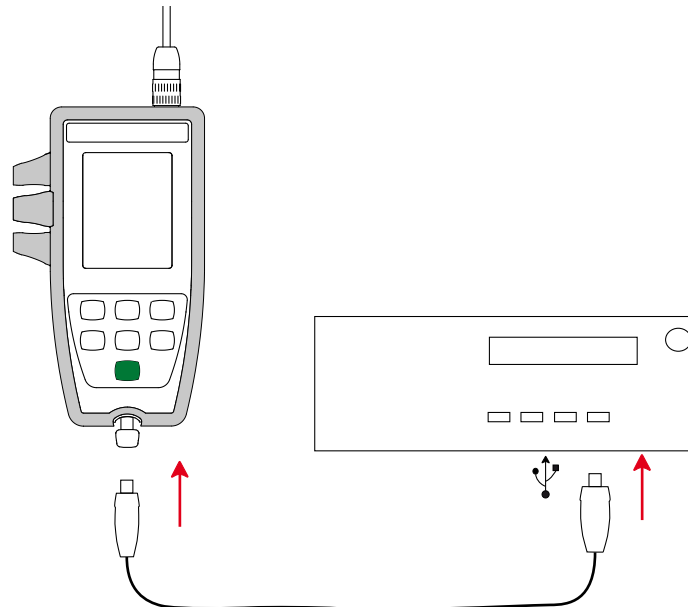

- Copy the .bin file to the instrument as if were a USB key.
- When the copying is done, press the **MEM** key and the instrument displays **LOAD**, indicating that the software is being installed.

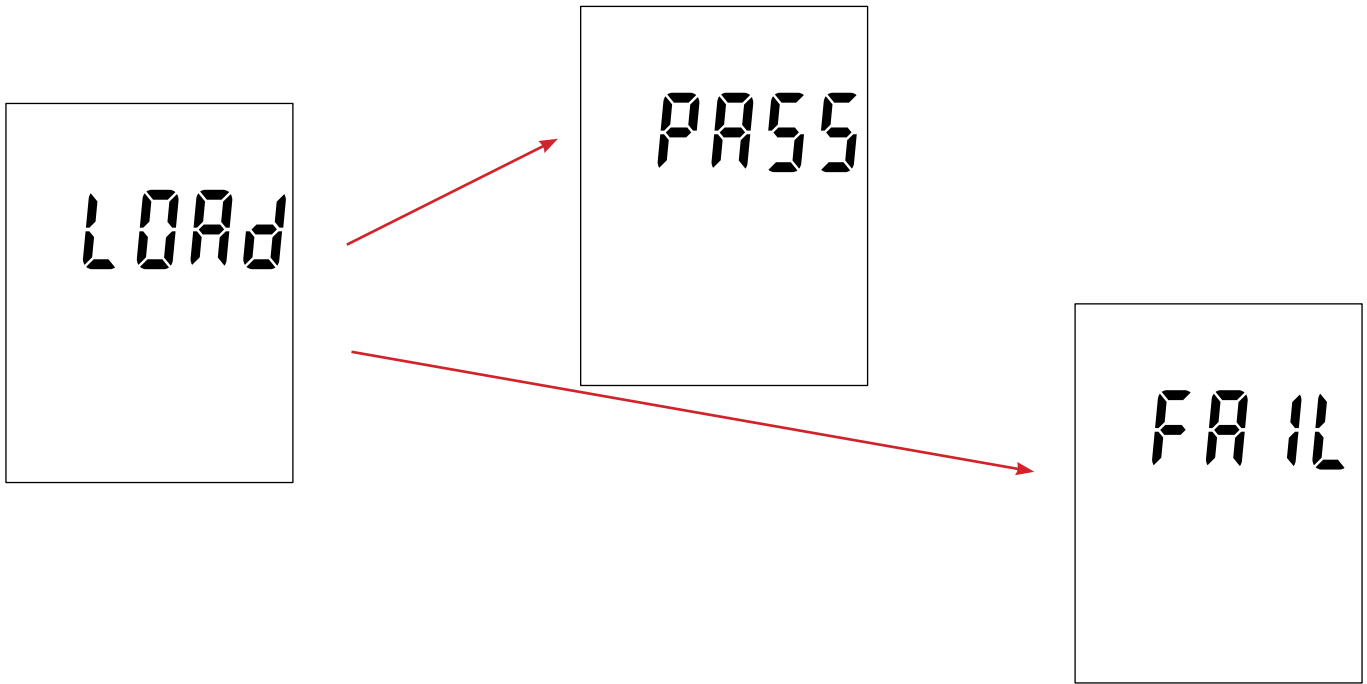

- When installation is done, the instrument displays **PASS** or **FAIL** according to whether or not the operation succeeded. If installation fails, download the software again and repeat the procedure.
- Then the instrument restarts normally.



After the internal software is updated, it may be necessary to reconfigure the instrument; see § 4.4.

7. WARRANTY

Except as otherwise stated, our warranty is valid for **24 months** starting from the date on which the equipment was sold. Extract from our General Conditions of Sale provided on request.

The warranty does not apply in the following cases:

- Inappropriate use of the equipment or use with incompatible equipment;
- Modifications made to the equipment without the explicit permission of the manufacturer's technical staff;
- Work done on the device by a person not approved by the manufacturer;
- Adaptation to a particular application not anticipated in the definition of the equipment or not indicated in the user's manual;
- Damage caused by shocks, falls, or floods.

The conductivity cells are wear parts. The life of your cell depends on how you use and maintain it. The cells are warranted for **12 months**.

8. APPENDIX 1: NONLINEAR TEMPERATURE CORRECTION OF THE CONDUCTIVITY

The nonlinear correction concerns natural water: underground water, surface water, drinking water, and sewage. It is defined by ISO/DIN standard 7888, between 0 and 35.9°C. It is especially useful for low conductivity values.

The table below indicates the nonlinear correction, f_{25} , applied to refer the conductivity measured at a temperature T to the 25°C reference temperature.

$$\sigma \text{ at } 25^\circ\text{C} = \sigma(T) \cdot f_{25}(T)$$

°C / 10 °C	.0	.1	.2	.3	.4	.5	.6	.7	.8	.9
0	1.918	1.912	1.906	1.899	1.893	1.887	1.881	1.875	1.869	1.863
1	1.857	1.851	1.845	1.840	1.834	1.829	1.822	1.817	1.811	1.805
2	1.800	1.794	1.788	1.783	1.777	1.772	1.766	1.761	1.756	1.750
3	1.745	1.740	1.734	1.729	1.724	1.719	1.713	1.708	1.703	1.696
4	1.693	1.688	1.683	1.678	1.673	1.668	1.663	1.658	1.653	1.648
5	1.643	1.638	1.634	1.629	1.624	1.619	1.615	1.610	1.605	1.601
6	1.596	1.591	1.587	1.582	1.578	1.573	1.569	1.564	1.560	1.556
7	1.551	1.547	1.542	1.538	1.534	1.529	1.525	1.521	1.516	1.512
8	1.508	1.504	1.500	1.496	1.491	1.487	1.483	1.479	1.475	1.471
9	1.467	1.463	1.459	1.455	1.451	1.447	1.443	1.439	1.436	1.432
10	1.428	1.424	1.420	1.416	1.413	1.409	1.405	1.401	1.398	1.394
11	1.390	1.387	1.383	1.379	1.376	1.372	1.369	1.365	1.362	1.358
12	1.354	1.351	1.347	1.344	1.341	1.337	1.334	1.330	1.327	1.323
13	1.320	1.317	1.313	1.310	1.307	1.303	1.300	1.297	1.294	1.290
14	1.287	1.284	1.281	1.278	1.274	1.271	1.268	1.265	1.262	1.259
15	1.256	1.253	1.249	1.246	1.243	1.240	1.237	1.234	1.231	1.228
16	1.225	1.222	1.219	1.216	1.214	1.211	1.208	1.205	1.020	1.199
17	1.196	1.193	1.191	1.188	1.185	1.182	1.179	1.177	1.174	1.171
18	1.168	1.166	1.163	1.160	1.157	1.155	1.152	1.149	1.147	1.144
19	1.141	1.139	1.136	1.134	1.131	1.128	1.126	1.123	1.121	1.118
20	1.116	1.113	1.111	1.108	1.105	1.103	1.101	1.098	1.096	1.093
21	1.091	1.088	1.086	1.083	1.081	1.079	1.076	1.074	1.071	1.069
22	1.067	1.064	1.062	1.060	1.057	1.055	1.053	1.051	1.048	1.046
23	1.044	1.041	1.039	1.037	1.035	1.032	1.030	1.028	1.026	1.024
24	1.021	1.019	1.017	1.015	1.013	1.011	1.008	1.006	1.004	1.002
25	1.000	0.998	0.996	0.994	0.992	0.990	0.987	0.985	0.983	0.981
26	0.979	0.977	0.975	0.973	0.971	0.969	0.967	0.965	0.963	0.961
27	0.959	0.957	0.955	0.953	0.952	0.950	0.948	0.946	0.944	0.942
28	0.940	0.938	0.936	0.934	0.933	0.931	0.929	0.927	0.925	0.923
29	0.921	0.920	0.918	0.916	0.914	0.912	0.911	0.909	0.907	0.905
30	0.903	0.902	0.900	0.898	0.896	0.895	0.893	0.891	0.889	0.888
31	0.886	0.884	0.883	0.881	0.879	0.877	0.876	0.874	0.872	0.871
32	0.869	0.867	0.866	0.864	0.863	0.861	0.859	0.858	0.856	0.854
33	0.853	0.851	0.850	0.848	0.846	0.845	0.843	0.842	0.840	0.839
34	0.837	0.835	0.834	0.832	0.831	0.829	0.828	0.826	0.825	0.823
35	0.822	0.820	0.819	0.817	0.816	0.814	0.813	0.811	0.810	0.808

To refer the measured values to 20°C, $f_{20}(T) = f_{25}(T) / 1.116$.

9. APPENDIX 2: SALINITY CALCULATION

Practical salinity S_p , referred to 15°C, is defined by UNESCO using the PSS-78 equation, for a temperature of the solution ranging from -2 to +35°C and a pressure close to one standard atmosphere:

$$S_p = \sum_{i=0}^5 a_i \cdot R_t^{i/2} + \frac{(T-15)}{1+k(T-15)} \sum_{i=0}^5 b_i \cdot R_t^{i/2}$$

With:

i	a_i	b_i
0	0,0080	0,0005
1	-0,1692	-0,0056
2	25,3851	-0,0066
3	14,0941	-0,0375
4	-7,0261	0,0636
5	2,7081	-0,0144

$k = 0,0162$

T = Temperature

$R_t = R_{\text{sample}}(T) / R_{\text{KCl}}(T)$ where $R = 1/\sigma$

FRANCE

Chauvin Arnoux

12-16 rue Sarah Bernhardt

92600 Asnières-sur-Seine

Tél : +33 1 44 85 44 85

Fax : +33 1 46 27 73 89

info@chauvin-arnoux.com

www.chauvin-arnoux.com

INTERNATIONAL

Chauvin Arnoux

Tél : +33 1 44 85 44 38

Fax : +33 1 46 27 95 69

Our international contacts

www.chauvin-arnoux.com/contacts

