

LR8320

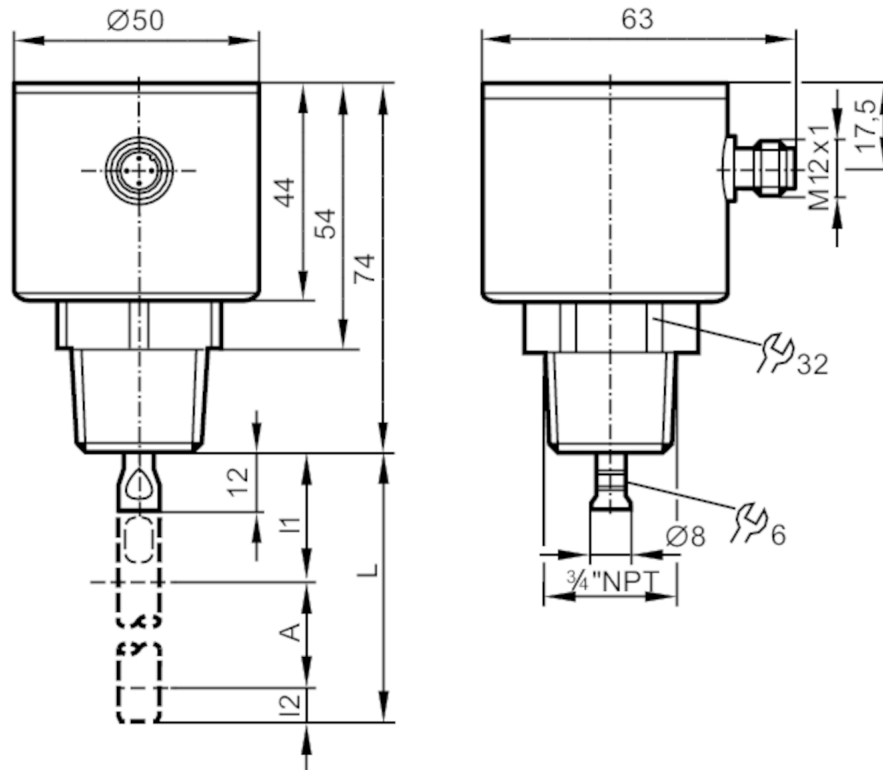

Continuous level sensor (guided wave radar)

LR0000--BN34ASPKG/US



A active range
I1 / I2 inactive ranges



Product characteristics

Number of inputs and outputs	Number of digital outputs: 4
Probe length L [mm]	100...2000
Process connection	3/4" NPT

Application

Special feature	Gold-plated contacts
Media	Liquids
Dielectric constant of the medium	> 5
Recommended media	water; hydrous media
Medium temperature [°C]	-25...80; (90: < 1 h)
Tank pressure [bar]	-1...16

Electrical data

Operating voltage [V]	18...30 DC
Current consumption [mA]	< 25
Protection class	III
Reverse polarity protection	yes
Power-on delay time [s]	< 3

LR8320



Continuous level sensor (guided wave radar)

LR0000--BN34ASPKG/US

Inputs / outputs	
Number of inputs and outputs	Number of digital outputs: 4
Outputs	
Total number of outputs	4
Output signal	switching signal; IO-Link
Electrical design	PNP/NPN
Number of digital outputs	4
Output function	normally open / normally closed; (parameterisable)
Max. voltage drop switching output DC [V]	2.5
Permanent current rating of switching output DC [mA]	200
Short-circuit protection	yes
Type of short-circuit protection	pulsed
Overload protection	yes
Measuring/setting range	
Probe length L [mm]	100...2000
Active range A [mm]	L-40
Inactive range I1 / I2 [mm]	30 / 10
Sampling rate [Hz]	4
Setting range	
Set point SP [mm]	≥ 15...L-30
Reset point rP [mm]	≥ 10...L-35
In steps of [mm]	5
Hysteresis [mm]	> 5
Accuracy / deviations	
Repeatability [mm]	5
Measuring error [% of the measured value]	± 7 mm
Offset error [mm]	5
Resolution [mm]	1
Temperature drift per 10 K	± 0.2 %

LR8320



Continuous level sensor (guided wave radar)

LR0000--BN34ASPKG/US

Interfaces	
Communication interface	IO-Link
Transmission type	COM2 (38,4 kBaud)
IO-Link revision	1.1
SDCI standard	IEC 61131-9
IO-Link device ID	979 d / 00 03 D3 h
Profiles	Smart Sensor: Process Data Variable; Device Identification, Device Diagnosis
SIO mode	yes
Required master port type	A
Process data analogue	3
Process data binary	4
Min. process cycle time [ms]	3.2

Operating conditions	
Ambient temperature [°C]	-25...60
Storage temperature [°C]	-40...85
Protection	IP 68; IP 69K; (IP68: 7 days / 1 m water depth / 0.1 bar)

Tests / approvals		
EMC	DIN EN 61000-6-2	
	DIN EN 61000-6-3	: in a closed metal tank
	DIN EN 61000-6-4	: in plastic or open metal tanks
Shock resistance	DIN EN 60068-2-27	50 g (11 ms) / 25 g (6 ms) with reference rod 0.5 m
Vibration resistance	DIN EN 60068-2-6	5 g (10...2000 Hz) / 1 g (5...200 Hz) with reference rod 0.5 m
MTTF [years]		242

Mechanical data	
Weight [g]	444.8
Materials	stainless steel (1.4301 / 304); stainless steel (1.4404 / 316L); FKM; PEI
Materials (wetted parts)	stainless steel (1.4305 / 303); probe connection: stainless steel (1.4435 / 316L); PTFE; FKM
Process connection	3/4" NPT

Remarks	
Pack quantity	1 pcs.

Electrical connection - plug

Connector: 1 x M12; Contacts: gold-plated

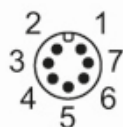

LR8320



Continuous level sensor (guided wave radar)

LR0000--BN34ASPKG/US

Connection

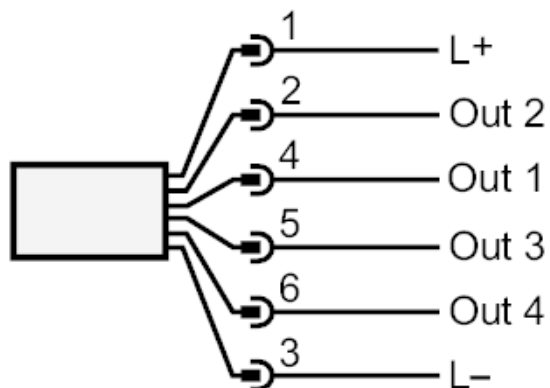

OUT1 : switching output or IO-Link

OUT2...4 : switching output

Diagrams and graphs

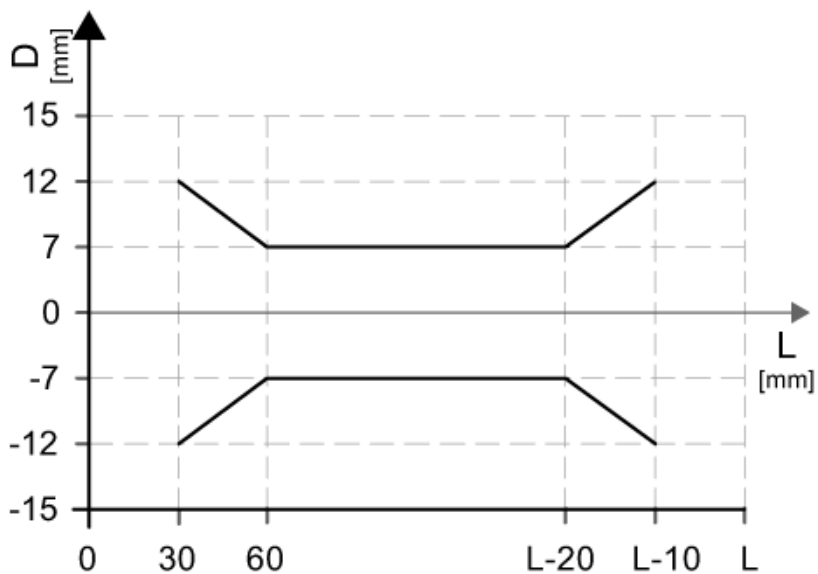

Measurement deviation D at the limits of the active rod range