

**BASE**

Glass-fibre reinforced polyamide based (PA) technopolymer, black colour, matte finish.

**ARTICULATED THROUGH STEM**

Threaded zinc-plated steel with regulation hexagon.

Assembled to the base by means of zinc-plated steel set screw and washer.

**CUP WASHER FOR STEM BEARING**

Glossy zinc-plated steel.

**STANDARD EXECUTIONS**

- **LV.F-ACV**: without no-slip disk.
- **LV.F-ACV-AS**: with NBR rubber no-slip disk, hardness 90 Shore A, supplied assembled, reinforced with zinc-plated steel plate, fixed by means of two screws.

**GROUND MOUNTING**

By means of two holes at 180°, supplied covered by a diaphragm (which can be easily removed by a metal tool), to avoid all unhealthy deposits of dirt and dust when the ground mounting is not required (see Fig. 1).

**FEATURES**

The special knurling under the lower lip of the base provides excellent stability and grip when using the levelling element without no-slip disk even on surfaces that are not perfectly flat. The components of the levelling elements (base and stem) are supplied already assembled.

**ACCESSORIES ON REQUEST**

Zinc-plated steel nut (see Nuts NT. on page 1137).

**SPECIAL EXECUTIONS ON REQUEST**

AISI 304 stainless steel stems.



ELESA Original design

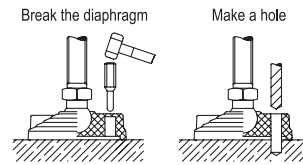
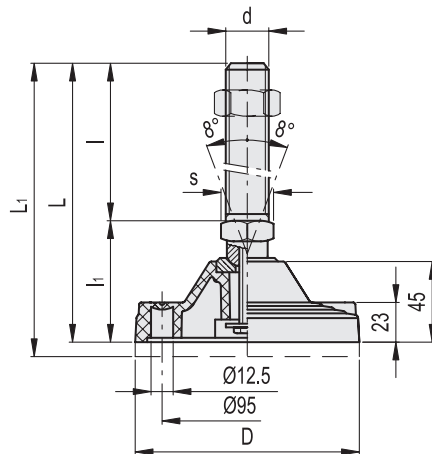

Fig.1



**LV.F-ACV**

**LV.F-ACV-AS**

Code	Description	Code	Description	D	d	L	L1#	l	l1	s	Max. limit stati load* [N]	⚖️	⚖️#
313921	LV.F-125-ACV-M20x136	316921	LV.F-125-ACV-AS-M20x136	125	M20	200	210	136	64	24	40000	585	835
313925	LV.F-125-ACV-M20x186	316925	LV.F-125-ACV-AS-M20x186	125	M20	250	260	186	64	24	40000	695	945
313931	LV.F-125-ACV-M24x136	316931	LV.F-125-ACV-AS-M24x136	125	M24	200	210	136	64	24	40000	735	985
313935	LV.F-125-ACV-M24x186	316935	LV.F-125-ACV-AS-M24x186	125	M24	250	260	186	64	24	40000	845	1095
313941	LV.F-125-ACV-M30x136	316941	LV.F-125-ACV-AS-M30x136	125	M30	200	210	136	64	30	40000	945	1195
313945	LV.F-125-ACV-M30x186	316945	LV.F-125-ACV-AS-M30x186	125	M30	250	260	186	64	30	40000	1035	1285

\* The max static load is the value above which the load applied to the element may cause some plastic material breakage, in particular conditions of use. Obviously, a factor that takes into consideration the importance and the safety level of the specific application must be applied to this value.

# Data with no-slip disk mounted.

