

VSP01A

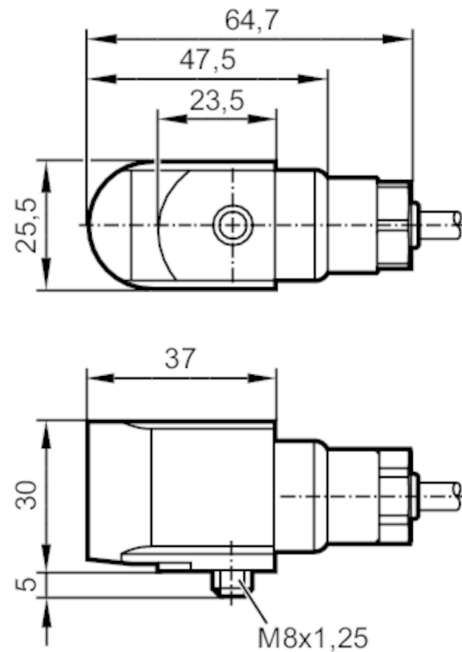

Acceleration sensor

VIBRATION SENSOR ATEX



Product characteristics

Measuring range of vibration	[g]	-50...50
Frequency range	[Hz]	2...10000

Application

Design	for connection to external diagnostic electronics VSExxx
--------	--

Electrical data

Switching amplifiers	connection to intrinsically safe supply isolators (Ex ia)	
Operating voltage	[V]	10...12 DC
Insulation rating	[V]	500
Current consumption	[mA]	0.5...8
Protection class		III
Reverse polarity protection		yes

Outputs

Max. load	[Ω]	200
Short-circuit protection		yes
Overload protection		yes

VSP01A



Acceleration sensor

VIBRATION SENSOR ATEX

Measuring/setting range		
Measuring range of vibration [g]	-50...50	
Frequency range [Hz]	2...10000	
Sensitivity [mV/g]	100	
Noise density [mg]	0.1	
Max. transverse sensitivity [%]	5	
Minimum measuring time [s]	2	
Number of measurement axes	1	
Operating conditions		
Ambient temperature [°C]	-55...90	
Storage temperature [°C]	-55...90	
Protection	IP 68; (water-proof up to: 100 m 10 bar; restrictions for 1D applications: IP65)	
Tests / approvals		
Approval	Baseefa12ATEX0248X; IECEx BAS 12.0133 X	
ATEX marking	Ex II 1G Ex ia IIC T4 Ga (-55°C < Ta < +90°C)	
	Ex II 1D Ex ia IIIC T110°C IP65 Da (-55°C < Ta < +90°C)	
	Ex II 1G Ex ia IIC T6 Ga (-55°C < Ta < +60°C)	
	Ex II 1D Ex ia IIIC T80°C IP65 Da (-55°C < Ta < +60°C)	
EMC	EN 61000-6-2	2005
	EN 61000-6-4	2007
Shock resistance		5000 g
Mechanical data		
Weight [g]	668.5	
Type of mounting	M8 x 1,25	
Dimensions [mm]	30 x 25.5 x 64.7	
Materials	housing: stainless steel	
Tightening torque [Nm]	8	
Accessories		
Accessories (optional)	Safety barrier ZB0633	
Remarks		
Pack quantity	1 pcs.	
Electrical connection		
Cable: 10 m, PUR		
white	Sensor supply / signal	
black	0 V	
screen	drain wire	