



Model number

INY030D-F99-2I2E2-5M

Features

- E1-Type approval
- Measuring range -15° ... $+15^{\circ}$
- Analog output 4 mA ... 20 mA
- Fixed evaluation limits
- High shock resistance
- Increased noise immunity 100 V/m

Electrical connection

Standard symbol/Connection:

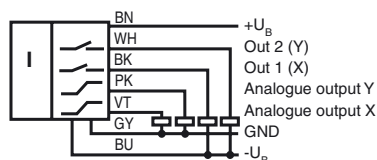

Technical Data

General specifications

Type	Inclination sensor, 2-axis
Measurement range	$-15 \dots 15^{\circ}$
Absolute accuracy	$\leq \pm 0.2^{\circ}$
Response delay	≤ 25 ms
Resolution	$\leq 0.01^{\circ}$
Repeat accuracy	$\leq \pm 0.02^{\circ}$
Temperature influence	$\leq 0.004^{\circ}/K$

Functional safety related parameters

MTTF _d	304 a
Mission Time (T _M)	20 a
Diagnostic Coverage (DC)	0 %

Indicators/operating means

Operation indicator	LED, green
Switching state	2 yellow LEDs: Switching status (each output)

Electrical specifications

Operating voltage U _B	10 ... 30 V DC
No-load supply current I ₀	≤ 25 mA
Time delay before availability t _v	≤ 200 ms

Switching output

Output type	2 switch outputs PNP, NO, reverse polarity protected, short-circuit protected
Operating current I _L	≤ 100 mA
Voltage drop	≤ 3 V

Analog output

Output type	2 current outputs 4 ... 20 mA (one output for each axis)
Load resistor	0 ... 200 Ω at U _B = 10 ... 18 V 0 ... 500 Ω at U _B = 18 ... 30 V

Ambient conditions

Ambient temperature	$-40 \dots 85^{\circ}C$ ($-40 \dots 185^{\circ}F$)
Storage temperature	$-40 \dots 85^{\circ}C$ ($-40 \dots 185^{\circ}F$)

Mechanical specifications

Connection type	5 m, PUR cable 7 x 0.5 mm ²
Housing material	PA
Degree of protection	IP68 / IP69K
Mass	240 g

Factory settings

Analog output (X)	-15° ... 15°
Analog output (Y)	-15° ... 15°
Switching output (X)	-15° ... 15°
Switching output (Y)	-15° ... 15°

Compliance with standards and directives

Standard conformity	
Shock and impact resistance	100 g according to DIN EN 60068-2-27
Standards	EN 60947-5-2:2007 IEC 60947-5-2:2007

Approvals and certificates

UL approval	cULus Listed, Class 2 Power Source
CSA approval	cCSAus Listed, General Purpose, Class 2 Power Source
E1 Type approval	10R-04

EMC Properties

Interference immunity in accordance with
DIN ISO 11452-2: 100 V/m
Frequency band 20 MHz up to 2 GHz
Mains-borne interference in accordance with ISO 7637-2:

Pulse	1	2a	2b	3a	3b	4
Severity level	III	III	III	III	III	III
Failure criterion	C	A	C	A	A	C

EN 61000-4-2: CD: 8 kV / AD: 15 kV

Severity level IV IV

EN 61000-4-3: 30 V/m (80...2500 MHz)

Severity level IV

EN 61000-4-4: 2 kV

Severity level III

EN 61000-4-6: 10 V (0.01...80 MHz)

Severity level III

EN 55011: Klasse A

Dimensions

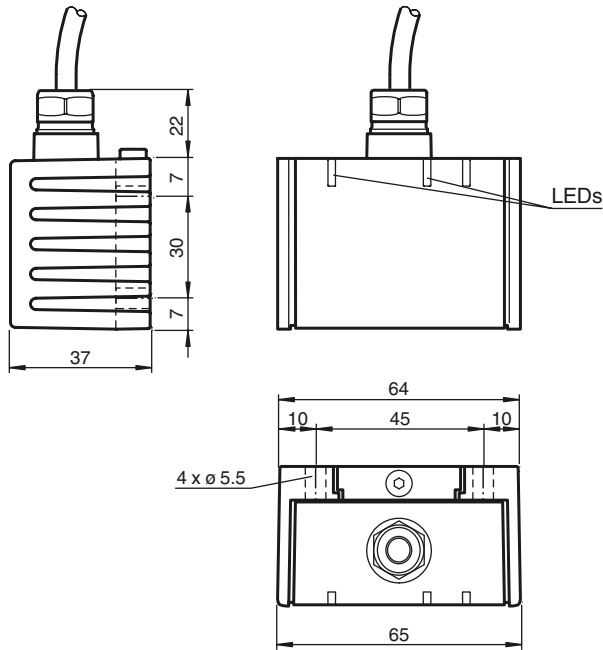

Sensor Orientation

In the default setting the zero position of the sensor is reached, when the sensor is mounted on a horizontal plane and electrical connection faces sideways.

Mounting of the sensor

Sensors from the -F99 series consist of a sensor module and accompanying cast aluminum housing. Select a horizontal flat surface with minimum dimensions of 70 mm x 50 mm to mount the sensor.

Mount the sensor as follows:



1. Loosen the central screw under the sensor connection.
 2. Slide back the clamping element until you are able to remove the sensor module from the housing.
 3. Remove the sensor module from the housing
 4. Position the housing at the required mounting location and secure using four countersunk screws. Make sure that the heads of the screws do not protrude.
 5. Place the sensor module in the housing.
 6. Slide the clamping element flush into the housing. Check that the sensor element is seated correctly.
 7. Finally tighten the central screw.
- The sensor is now mounted correctly.