

# PRODUKTDATENBLATT

## POLO-KAL NG Abzweig 250/250/87

Artikel-Nr. 02980

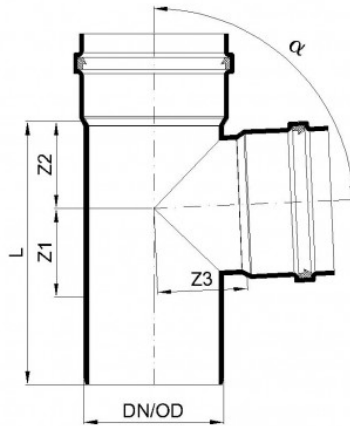

PURE  
PROGRESS / poloplast

### Technische Daten

DN/OD	250
DN/OD2	250
Winkel $\alpha$	87,5°
Länge L	471 mm
Z1	159 mm
Z2	156 mm
Z3	161 mm
Gewicht	7,47 kg/Stk.
Verpackungseinheit	1 Stk.