

SO SERIES

PRECISION BOARD STACKING STANDOFF

SPECIFICATIONS

For complete specifications and recommended PCB layouts see www.samtec.com?SO

Material: Aluminum
Locking Compound: Nylon

APPLICATIONS

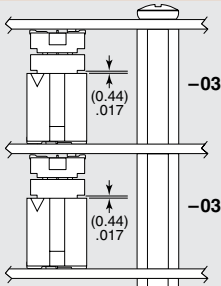

See QMS/QFS Series SUMIT™ & PCI/104-Express™ connectors

Requires Standoff SO-1524-03-01-02-L 15.24mm board spacing. Connectors designed to not fully seat when mated.

APPLICATIONS

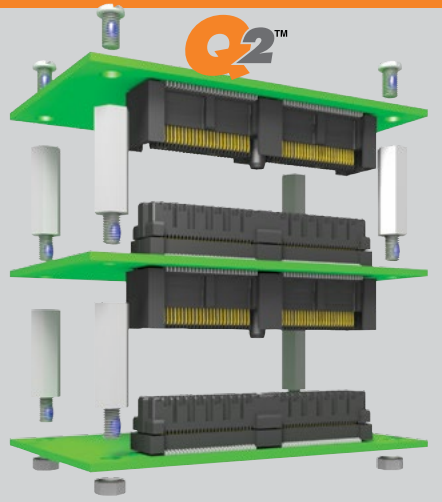

Ideal for use with all Samtec SI connectors

Precision machined tolerances ($\pm .002"$ (0.05 mm))

RUGGEDIZED
BY SAMTEC

- Precision machined
- Locking compound

Stack heights from 5 mm to 25 mm

#4-40 Thread

Standard Nylon thread locking compound

ALSO AVAILABLE
(MOQ Required)

- Other heights
 - Stainless Steel
 - Locking compound removed
 - Other materials and threading
 - No Hardware
- Contact Samtec.

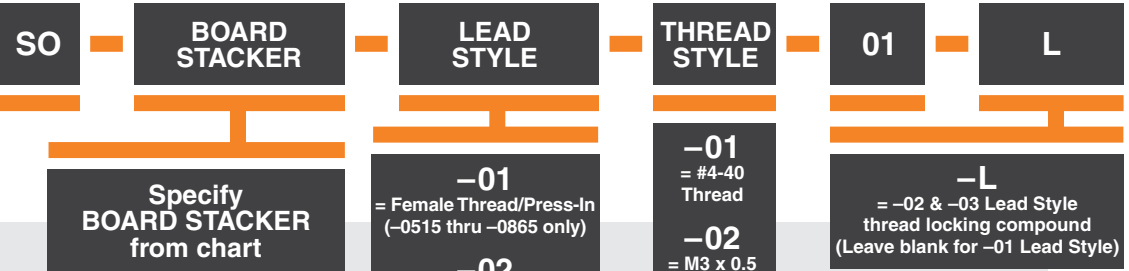

Specify BOARD STACKER from chart

BOARD STACKER	A	BOARD STACK HEIGHT
-0515	(5.15) .203	5 mm
-0715	(7.15) .282	7 mm
-0815	(8.15) .321	8 mm
-0865	(8.65) .341	8.5 mm
-1115	(11.15) .439	11 mm
-1215	(12.15) .478	12 mm
-1524	(15.24) .600	15.09 mm
-1615	(16.15) .636	16 mm
-1890	(18.90) .744	18.75 mm
-1915	(19.15) .754	19 mm
-2515	(25.15) .990	25 mm

Notes:
 Standoffs are designed, 0.15 mm longer than connector stack heights to allow for processing variables.
 Some lengths, styles and options are non-standard, non-returnable.

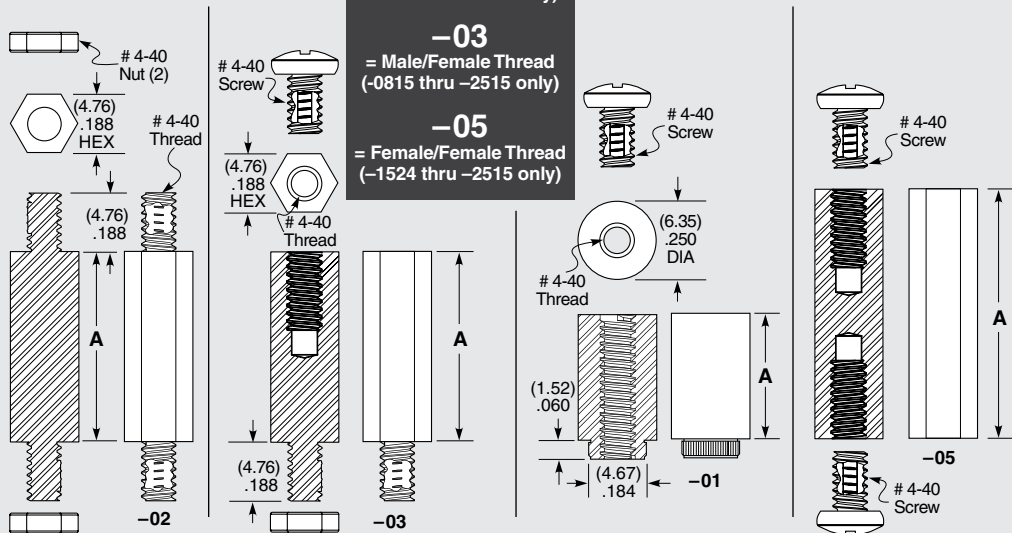

Components are to be packaged in separate bags unassembled.

Due to technical progress, all designs, specifications and components are subject to change without notice.

WWW.SAMTEC.COM

All parts within this catalog are built to Samtec's specifications. Customer specific requirements must be approved by Samtec and identified in a Samtec customer-specific drawing to apply.