



# UFS Memory

## MTFC32GASAO, MTFC64GASAO, MTFC128GASAO, MTFC256GASAO

### Features

- Universal flash storage (UFS) controller and NAND Flash
- $V_{CC}$ : 2.7–3.6V
- $V_{CCQ2}$ : 1.7–1.95V
- JEDEC/UFS specification version 2.1-compliant<sup>1</sup>
  - Advanced 6-signal interface
  - Differential I/O pins
  - 2 lanes supported
  - High speed: Gear 1/2/3 supported
  - Permanent and power-on write protection
  - Boot operation (high-speed boot)
  - Sleep mode
  - Replay-protected memory block (RPMB)
  - Background operation
  - Reliable write
  - Discard/Erase
  - Command queuing
  - FFU
  - Cache
- JEDEC/UFS specification version 3.0-features<sup>2</sup>
  - REFRESH operation
  - Temperature event notification
- Automotive grade:
  - AEC-Q104
  - PPAP
- Retention AEC-Q100-005 compliant:
  - 5 years @55°C at 10% of PE
  - 1 year @55°C at maximum PE
- Package compliance:
  - RoHS certification
  - BGA, MSL3

### Options

- Density
  - 32GB
  - 64GB
  - 128GB
  - 256GB
- NAND component
  - 256Gb
- Controller
- Packages
  - 153-ball JEDEC TFBGA
- Special option
  - Automotive grade
- Operating temperature ranges<sup>3</sup>
  - From –40°C to +95°C
  - From –40°C to +105°C

### Marking

	32G
	64G
	128G
	256G
	AS
	AO
	NS
	A
	IT
	AT

- Notes:
1. The JEDEC specification is available at <https://www.jedec.org/sites/default/files/docs/JESD220C.pdf>.
  2. The JEDEC specification is available at <https://www.jedec.org/sites/default/files/docs/JESD220D.pdf>.
  3. Operating temperature ( $T_{OPER}$ ) is the case surface temperature on the center/top of the package.



## Part Numbering Information

Micron® UFS memory devices are available in different configurations and densities.

**Figure 1: UFS Part Numbering**

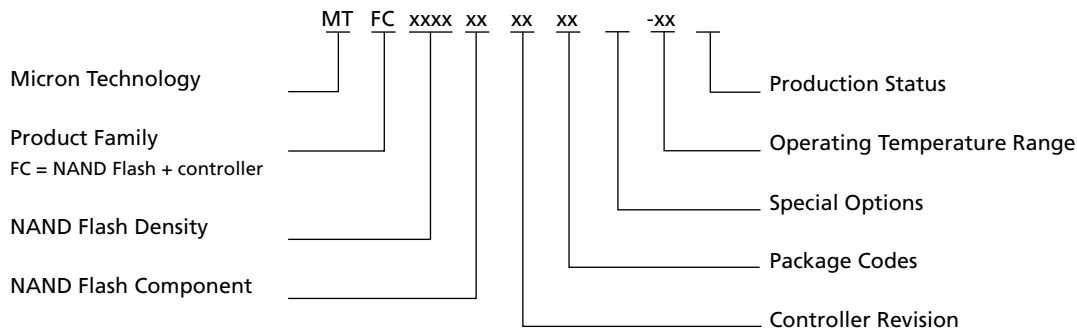

**Table 1: Ordering Information**

Base Part Number	Density	Package	Notes
MTFC32GASAONS-AIT MTFC32GASAONS-AAT	32GB	153-ball JEDEC TFBGA 11.5mm x 13mm x 1.2mm	1
MTFC64GASAONS-AIT MTFC64GASAONS-AAT	64GB	153-ball JEDEC TFBGA 11.5mm x 13mm x 1.2mm	1
MTFC128GASAONS-AIT MTFC128GASAONS-AAT	128GB	153-ball JEDEC TFBGA 11.5mm x 13mm x 1.2mm	1
MTFC256GASAONS-AIT MTFC256GASAONS-AAT	256GB	153-ball JEDEC TFBGA 11.5mm x 13mm x 1.2mm	1

Note: 1. All the above MPNs can be ordered in the shipping form of tray and tape and reel.

## Device Marking

Due to the size of the package, the Micron-standard part number is not printed on the top of the device. Instead, an abbreviated device mark consisting of a 5-digit alphanumeric code is used. The abbreviated device marks are cross-referenced to the Micron part numbers at the FBGA Part Marking Decoder site: [www.micron.com/decoder](http://www.micron.com/decoder).



**Contents**

Important Notes and Warnings ..... 6

General Description ..... 7

UFS Performance and Current Consumption ..... 8

Signal Descriptions ..... 9

Signal Assignments ..... 10

Package Dimensions ..... 11

Architecture ..... 12

UFS M-PHY Attributes ..... 13

UPIU Transaction Codes ..... 14

UFS Descriptors ..... 16

UFS Flags, Attributes, and Commands ..... 33

UFS Supported Pages ..... 41

UFS Vital Product Data Parameters ..... 47

Electrical Specifications ..... 55

Revision History ..... 56

    Rev.G – 05/20 ..... 56

    Rev.F – 12/19 ..... 56

    Rev. E – 10/19 ..... 56

    Rev. D – 06/19 ..... 56

    Rev. C – 02/19 ..... 56

    Rev. B – 11/18 ..... 56

    Rev. A – 10/18 ..... 56



## List of Figures

Figure 1: UFS Part Numbering .....	2
Figure 2: 153-Ball JEDEC (Top View, Ball Down) .....	10
Figure 3: 153-Ball TFBGA – 11.5mm × 13.0mm × 1.2mm (Package Code: NS) .....	11
Figure 4: UFS Functional Block Diagram .....	12



## List of Tables

Table 1: Ordering Information .....	2
Table 2: Performance .....	8
Table 3: Active Current Consumption .....	8
Table 4: Low-Power Mode .....	8
Table 5: Signal Descriptions .....	9
Table 6: Recommended Capacitor Values .....	12
Table 7: PHY M-TX Capability Attributes .....	13
Table 8: PHY M-RX Capability Attributes .....	13
Table 9: UPIU Transaction Codes .....	15
Table 10: Descriptor Identification Values .....	16
Table 11: Configuration Descriptor .....	16
Table 12: Device Descriptor .....	17
Table 13: Geometry Descriptor .....	21
Table 14: Unit Descriptor .....	25
Table 15: RPMB Unit Descriptor .....	27
Table 16: Power Parameters Descriptor .....	28
Table 17: Interconnect Descriptor .....	29
Table 18: Manufacturer Name String Descriptor .....	29
Table 19: Product Name String Descriptor .....	29
Table 20: OEM ID String Descriptor .....	31
Table 21: Serial Number String Descriptor .....	32
Table 22: Product Revision Level String Descriptor .....	32
Table 23: Device Health Descriptor .....	32
Table 24: Flags .....	33
Table 25: Attributes .....	35
Table 26: SCSI Commands .....	39
Table 27: UFS Supported Pages .....	41
Table 28: Control Mode Page .....	41
Table 29: Read – Write Error Recovery Mode Page .....	43
Table 30: Caching Mode Page .....	44
Table 31: Supported VPD Pages .....	47
Table 32: Unit Serial Number VPD Page .....	47
Table 33: Device Identification VPD Page .....	48
Table 34: Mode Page Policy VPD Page .....	49
Table 35: Block Limits VPD Page .....	50
Table 36: Block Device Characteristics .....	52
Table 37: Logical Block Provisioning .....	53
Table 38: Standard Inquiry Data .....	54
Table 39: Power Supply Parameters .....	55
Table 40: Reference Clock Parameters <sup>1</sup> .....	55



## Important Notes and Warnings

Micron Technology, Inc. ("Micron") reserves the right to make changes to information published in this document, including without limitation specifications and product descriptions. This document supersedes and replaces all information supplied prior to the publication hereof. You may not rely on any information set forth in this document if you obtain the product described herein from any unauthorized distributor or other source not authorized by Micron.

**Automotive Applications.** Products are not designed or intended for use in automotive applications unless specifically designated by Micron as automotive-grade by their respective data sheets. Distributor and customer/distributor shall assume the sole risk and liability for and shall indemnify and hold Micron harmless against all claims, costs, damages, and expenses and reasonable attorneys' fees arising out of, directly or indirectly, any claim of product liability, personal injury, death, or property damage resulting directly or indirectly from any use of non-automotive-grade products in automotive applications. Customer/distributor shall ensure that the terms and conditions of sale between customer/distributor and any customer of distributor/customer (1) state that Micron products are not designed or intended for use in automotive applications unless specifically designated by Micron as automotive-grade by their respective data sheets and (2) require such customer of distributor/customer to indemnify and hold Micron harmless against all claims, costs, damages, and expenses and reasonable attorneys' fees arising out of, directly or indirectly, any claim of product liability, personal injury, death, or property damage resulting from any use of non-automotive-grade products in automotive applications.

**Critical Applications.** Products are not authorized for use in applications in which failure of the Micron component could result, directly or indirectly in death, personal injury, or severe property or environmental damage ("Critical Applications"). Customer must protect against death, personal injury, and severe property and environmental damage by incorporating safety design measures into customer's applications to ensure that failure of the Micron component will not result in such harms. Should customer or distributor purchase, use, or sell any Micron component for any critical application, customer and distributor shall indemnify and hold harmless Micron and its subsidiaries, subcontractors, and affiliates and the directors, officers, and employees of each against all claims, costs, damages, and expenses and reasonable attorneys' fees arising out of, directly or indirectly, any claim of product liability, personal injury, or death arising in any way out of such critical application, whether or not Micron or its subsidiaries, subcontractors, or affiliates were negligent in the design, manufacture, or warning of the Micron product.

**Customer Responsibility.** Customers are responsible for the design, manufacture, and operation of their systems, applications, and products using Micron products. ALL SEMICONDUCTOR PRODUCTS HAVE INHERENT FAILURE RATES AND LIMITED USEFUL LIVES. IT IS THE CUSTOMER'S SOLE RESPONSIBILITY TO DETERMINE WHETHER THE MICRON PRODUCT IS SUITABLE AND FIT FOR THE CUSTOMER'S SYSTEM, APPLICATION, OR PRODUCT. Customers must ensure that adequate design, manufacturing, and operating safeguards are included in customer's applications and products to eliminate the risk that personal injury, death, or severe property or environmental damages will result from failure of any semiconductor component.

**Limited Warranty.** In no event shall Micron be liable for any indirect, incidental, punitive, special or consequential damages (including without limitation lost profits, lost savings, business interruption, costs related to the removal or replacement of any products or rework charges) whether or not such damages are based on tort, warranty, breach of contract or other legal theory, unless explicitly stated in a written agreement executed by Micron's duly authorized representative.



## 32GB, 64GB, 128GB, 256GB: Automotive UFS Memory General Description

---

### General Description

Micron universal flash storage (UFS) is a communication and mass data storage device that includes an M-PHY interface, one or more NAND Flash components, and a controller on an advanced 6-signal bus, which is compliant with the UFS system specification. Its cost per bit, small package sizes, and high reliability make it an ideal choice for automotive applications, including information and entertainment, navigation tools, advanced driving assistance systems, and a variety of other industrial and portable products.

The nonvolatile UFS draws no power to maintain stored data, delivers high performance across a wide range of operating temperatures, and resists shock and vibration disruption.



## 32GB, 64GB, 128GB, 256GB: Automotive UFS Memory UFS Performance and Current Consumption

### UFS Performance and Current Consumption

**Table 2: Performance**

Condition <sup>1</sup>		Typical Values				Unit
		32GB	64GB	128GB	256GB	
Sequential	Write	130	250	500	625	MB/s
	Read	500	940	950	950	MB/s
Random	Write	24,000	49,000	65,000	65,000	IOPS
	Read	26,000	47,000	70,000	70,000	IOPS

Note: 1. Two lanes, high-speed mode gear 3; Sequential access of 512KB chunk; Random access of 4KB chunk; Command queue depth = 32; Burst performance.

Additional performance data is provided in a separate document upon customer request, such as sustained and system performance on a specific application board, in system programming performance in manufacturing environment with Micron proprietary solution.

**Table 3: Active Current Consumption**

Condition	Typical Values ( $I_{CC}/I_{CCQ2}$ ) <sup>1</sup>				Peak Values ( $I_{CC}/I_{CCQ2}$ ) <sup>2</sup>				Unit
	32GB	64GB	128GB	256GB	32GB	64GB	128GB	256GB	
Write	60/365	105/365	150/365	255/365	250/560	400/560	550/560	700/560	mA
Read	50/465	105/465	115/465	130/465	200/560	360/560	450/560	510/560	mA

Notes: 1. Two lanes, high-speed mode gear 3;  $V_{CC} = 3.3V$ ;  $V_{CCQ2} = 1.8V$ ;  $T_{OPER} = 85^{\circ}C$ , measurements done as average RMS current consumption.

2. Two lanes, high-speed mode gear 3;  $V_{CC} = 3.3V$ ;  $V_{CCQ2} = 1.8V$ ;  $T_{OPER} = 85^{\circ}C$ , measurements done as maximum of average values in any 4 $\mu$ s operation windows.

**Table 4: Low-Power Mode**

Condition <sup>1</sup>	Typical Values ( $I_{CC}/I_{CCQ2}$ )				Maximum Values ( $I_{CC}/I_{CCQ2}$ )				Unit
	32GB	64GB	128GB	256GB	32GB	64GB	128GB	256GB	
Sleep	35/500	45/500	70/500	120/500	70/650	100/650	150/650	300/650	$\mu$ A
Idle	35/500	45/500	70/500	120/500	70/650	100/650	150/650	300/650	$\mu$ A

Note: 1. Two lanes, low-speed mode PWM gear 1, M-PHY in Hibernate;  $V_{CC} = 3.3V$ ;  $V_{CCQ2} = 1.8V$ ;  $T_{OPER} = 25^{\circ}C$ .





## Signal Descriptions

**Table 5: Signal Descriptions**

Symbol	Type	Description
REF_CLK	Input	Reference clock: When not active, this signal should be pull-down or driven LOW by the host SoC
RST_n	Input	Hardware reset signal
D <sub>IN0_t</sub> , D <sub>IN0_c</sub>	Input	Downstream data lane 0: Differential input signals into UFS device from the host
D <sub>IN1_t</sub> , D <sub>IN1_c</sub>	Input	Downstream data lane 1: Differential input signals into UFS device from the host
D <sub>OUT0_t</sub> , D <sub>OUT0_c</sub>	Output	Upstream data lane 0: Differential output signals from the UFS device to the host
D <sub>OUT1_t</sub> , D <sub>OUT1_c</sub>	Output	Upstream data lane 1: Differential output signals from the UFS device to the host
VSF[9:1]	Input/ Output	Vendor specific function: VSF[9:1] must be left floating; VSF2 is not used. Exposing VSF balls on test points is recommended.
V <sub>CC</sub>	Supply	Supply voltage for the NAND memory device
V <sub>CCQ2</sub>	Supply	Supply voltage used for the M-PHY interface and the memory controller
V <sub>DDIQ</sub>	Input	Input terminal to provide bypass capacitor for internal regulator related to the memory controller
V <sub>SS</sub>	Supply	Ground
NC	–	No connect: NC pins must be connected to ground or left floating
RFU	–	Reserved for future use: RFU pins must be left floating



## Signal Assignments

Figure 2: 153-Ball JEDEC (Top View, Ball Down)

	1	2	3	4	5	6	7	8	9	10	11	12	13	14	
A	NC	NC	V <sub>DDiQ</sub>	NC	NC	V <sub>CCQ2</sub>	V <sub>CCQ2</sub>	NC	NC	NC	NC	NC	NC	NC	A
B	NC	V <sub>SS</sub>	RFU	NC	NC	V <sub>CCQ2</sub>	V <sub>CCQ2</sub>	V <sub>CC</sub>	V <sub>CC</sub>	NC	V <sub>SS</sub>	V <sub>SS</sub>	RFU	NC	B
C	V <sub>SS</sub>	V <sub>SS</sub>	V <sub>SS</sub>	NC	NC	V <sub>CCQ2</sub>	V <sub>CCQ2</sub>	V <sub>CC</sub>	V <sub>CC</sub>	RFU	V <sub>SS</sub>	V <sub>SS</sub>	RFU	RFU	C
D	D <sub>IN1-t</sub>	D <sub>IN1-c</sub>	V <sub>SS</sub>	NC								V <sub>SS</sub>	V <sub>SS</sub>	V <sub>SS</sub>	D
E	V <sub>SS</sub>	V <sub>SS</sub>	V <sub>SS</sub>		NC	VSF1	NC	V <sub>CC</sub>	VSF3	VSF4		V <sub>SS</sub>	RFU	RFU	E
F	D <sub>IN0-t</sub>	D <sub>IN0-c</sub>	V <sub>SS</sub>		NC					VSF5		V <sub>SS</sub>	V <sub>SS</sub>	V <sub>SS</sub>	F
G	V <sub>SS</sub>	V <sub>SS</sub>	V <sub>SS</sub>		VSF6					V <sub>SS</sub>		V <sub>SS</sub>	RFU	RFU	G
H	REF_CLK	RST_n	V <sub>SS</sub>		V <sub>SS</sub>					V <sub>SS</sub>		V <sub>SS</sub>	V <sub>SS</sub>	V <sub>SS</sub>	H
J	V <sub>SS</sub>	V <sub>SS</sub>	V <sub>SS</sub>		V <sub>SS</sub>					VSF7		V <sub>SS</sub>	RFU	RFU	J
K	D <sub>OUT0-c</sub>	D <sub>OUT0-t</sub>	V <sub>SS</sub>		V <sub>SS</sub>	V <sub>CCQ2</sub>	V <sub>CCQ2</sub>	V <sub>CC</sub>	NC	VSF8		V <sub>SS</sub>	V <sub>SS</sub>	V <sub>SS</sub>	K
L	V <sub>SS</sub>	V <sub>SS</sub>	V <sub>SS</sub>									V <sub>SS</sub>	RFU	RFU	L
M	D <sub>OUT1-c</sub>	D <sub>OUT1-t</sub>	V <sub>SS</sub>	V <sub>SS</sub>	V <sub>SS</sub>	RFU	RFU	NC	NC	RFU	NC	V <sub>SS</sub>	V <sub>SS</sub>	V <sub>SS</sub>	M
N	NC	V <sub>SS</sub>	V <sub>SS</sub>	V <sub>SS</sub>	V <sub>SS</sub>	RFU	RFU	V <sub>CC</sub>	V <sub>CC</sub>	RFU	V <sub>SS</sub>	V <sub>SS</sub>	RFU	NC	N
P	NC	NC	RFU	V <sub>SS</sub>	V <sub>SS</sub>	RFU	RFU	V <sub>CC</sub>	V <sub>CC</sub>	VSF9	V <sub>SS</sub>	V <sub>SS</sub>	NC	NC	P

Top View (ball down)

Note: 1. The following balls are not connected in this product family, although specified by JEDEC Standard No. 21-C: A[5:4], A[12:8], B[5:4], B10, C[5:4], E5, E7, and F5.



## 32GB, 64GB, 128GB, 256GB: Automotive UFS Memory Package Dimensions

### Package Dimensions

Figure 3: 153-Ball TFBGA – 11.5mm × 13.0mm × 1.2mm (Package Code: NS)

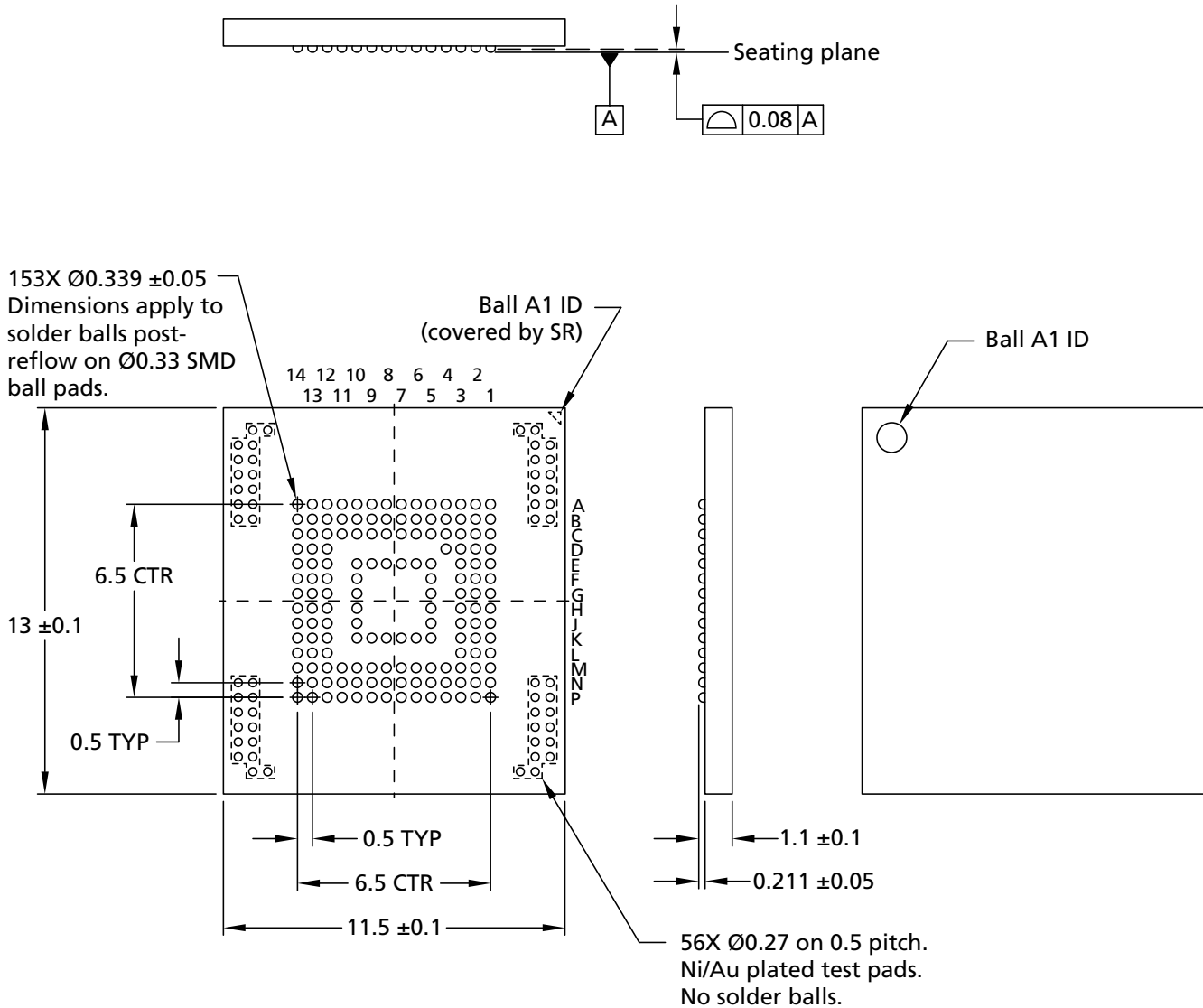

- Notes:
1. Dimensions are in millimeters.
  2. For optimal Solder Join Reliability (SJR) performance, refer to CSN33 for recommended PCB pad dimension to align to the SMD ball pad size of the package
  3. In the whole UFS package area, solder mask is recommended to cover the via pad in the PCB in order to avoid possible contact with Ni/Au-plated test pads on the UFS package.
  4. The Ni/Au-plated test pads on the UFS package are reserved for Micron internal use only.



## Architecture

Figure 4: UFS Functional Block Diagram

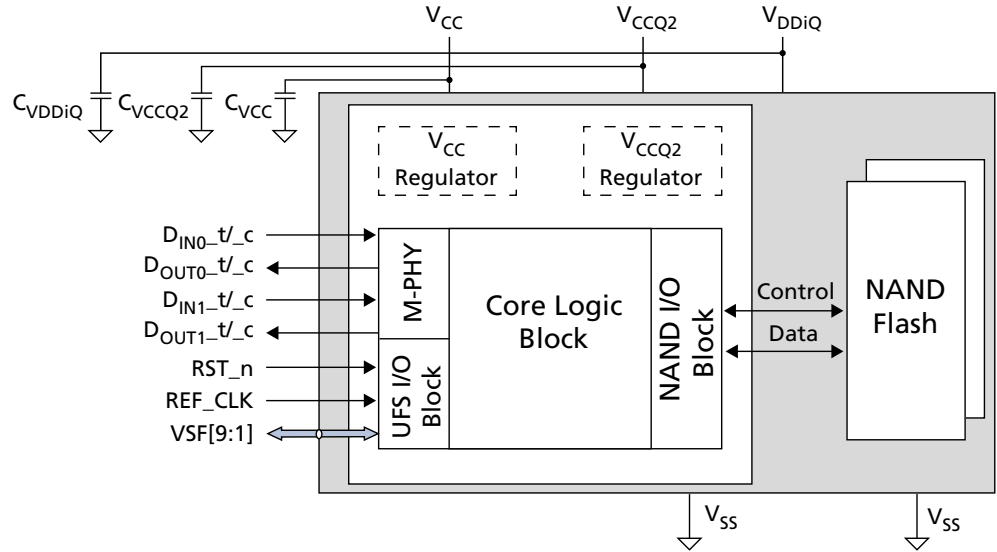

Table 6: Recommended Capacitor Values

Parameters	Symbol	Min	Typ	Max	Unit
V <sub>CC</sub> capacitor	C <sub>VCC</sub>	1.0	4.7	–	μF
V <sub>CCQ2</sub> capacitor	C <sub>VCCQ2</sub>	1.0	4.7	–	μF
V <sub>DDiQ</sub> capacitor <sup>2</sup>	C <sub>VDDiQ</sub>	0	4.7	–	μF

- Notes: 1. An additional capacitor on each of the three lines can be added with a value about 1/10<sup>th</sup> that of the current capacitors.  
 2. V<sub>DDiQ</sub> capacitor is optional.



## UFS M-PHY Attributes

Micron device supports 2 lanes configuration.

**Table 7: PHY M-TX Capability Attributes**

Name	ID	Value Lane 0 Lane 1	Type	Notes
TX_HSMODE_Capability	01h	01h	R	FALSE = 0, TRUE = 1
TX_HSGEAR_Capability	02h	03h	R	HS_G1_ONLY = 1 HS_G1_TO_G2 = 2 HS_G1_TO_G3 = 3
TX_PWMG0_Capability	03h	00h	R	0 = NO, 1 = YES
TX_PWMGEAR_Capability	04h	07h	R	Range from PWM_G1 to PWM_G7
TX_Amplitude_Capability	05h	03h	R	SA = 1, LA = 2, BOTH = 3
TX_ExternalSYNC_Capability	06h	01h	R	FALSE = 0, TRUE = 1
TX_HS_Unterminated_LINE_Drive_Capability	07h	01h	R	0 = NO, 1 = YES
TX_LS_Terminated_LINE_Drive_Capability	08h	01h	R	0 = NO, 1 = YES
TX_Min_SLEEP_NoConfig_Time_Capability	09h	08h	R	1 to 15
TX_Min_STALL_NoConfig_Time_Capability	0Ah	80h	R	1 to 255
TX_Min_SAVE_Config_Time_Capability	0Bh	7Fh	R	1 to 250
TX_REF_CLOCK_SHARED_Capability	0Ch	01h	R	0 = NO, 1 = YES
TX_PHY_MajorMinor_Release_Capability	0Dh	30h	R	Bit[7:4]: Major version number Bit[3:0]: Minor version number
TX_PHY_Editorial_Release_Capability	0Eh	01h	R	Bit[7:0] = 1 to 99
TX_Hibern8Time_Capability	0Fh	01h	R/W	1 to 128
TX_Advanced_Granularity_Capability	10h	05h	R/W	Bit[2:1]: Step size Bit[0]: Supports fine granularity steps
TX_Advanced_Hibern8Time_Capability	11h	07h	R/W	1 to 128
TX_HS_Equalizer_Setting_Capability	12h	03h	R	Bit[1:0]

**Table 8: PHY M-RX Capability Attributes**

Name	ID	Value Lane 0 Lane 1	Type	Notes
RX_HSMODE_Capability	81h	01h	R	0 = NO, 1 = YES
RX_HSGEAR_Capability	82h	03h	R	HS_G1_ONLY = 1 HS_G1_TO_G2 = 2 HS_G1_TO_G3 = 3
RX_PWMG0_Capability	83h	00h	R	0 = NO, 1 = YES
RX_PWMGEAR_Capability	84h	07h	R	Range from PWM_G1 to PWM_G7
RX_HS_Unterminated_LINE_Drive_Capability	85h	00h	R	0 = NO, 1 = YES
RX_LS_Terminated_LINE_Drive_Capability	86h	01h	R	0 = NO, 1 = YES
RX_Min_SLEEP_NoConfig_Time_Capability	87h	0Fh	R	1-15

**Table 8: PHY M-RX Capability Attributes (Continued)**

Name	ID	Value Lane 0 Lane 1	Type	Notes
RX_Min_STALL_NoConfig_Time_Capability	88h	FAh	R	1–255
RX_Min_SAVE_Config_Time_Capability	89h	FAh	R	1–250
RX_REF_CLOCK_SHARED_Capability	8Ah	01h	R/W	0 = NO, 1 = YES
RX_HS_G1_SYNC_LENGTH_Capability	8Bh	49h	R/W	Bit[7:6]: SYNC_range FINE = 0, COARSE = 1 Bit[5:0]: SYNC-length 1 to 15 for FINE, 0 to 15 for COARSE
RX_HS_G1_PREPARE_LENGTH_Capability	8Ch	0Fh	R	0–15
RX_LS_PREPARE_LENGTH_Capability	8Dh	06h	R	0–15
RX_PWM_Burst_Closure_Length_Capability	8Eh	1Fh	R/W	0–31
RX_Min_ActivateTime_Capability	8Fh	04h	R/W	1–9
RX_PHY_MajorMinor_Release_Capability	90h	30h	R	Bit[7:4]: Major version number Bit[3:0]: Minor version number
RX_PHY_Editorial_Release_Capability	91h	01h	R	1–99
RX_Hibern8Time_Capability	92h	01h	R/W	1–128
RX_PWM_G6_G7_SYNC_LENGTH_Capability	93h	0Fh	R/W	Bit[7:6]: SYNC_range FINE = 0, COARSE = 1 Bit[5:0]: SYNC-length 0 to 15
RX_HS_G2_SYNC_LENGTH_Capability	94h	4Ah	R/W	Bit[7:6]: SYNC_range FINE = 0, COARSE = 1 Bit[5:0]: SYNC-length 1 to 15 for FINE, 0 to 15 for COARSE
RX_HS_G3_SYNC_LENGTH_Capability	95h	4Bh	R/W	Bit[7:6]: SYNC_range FINE = 0, COARSE = 1 Bit[5:0]: SYNC-length 1 to 15 for FINE, 0 to 15 for COARSE
RX_HS_G2_PREPARE_LENGTH_Capability	96h	0Fh	R/W	Bit[3:0]: 0 to 15
RX_HS_G3_PREPARE_LENGTH_Capability	97h	0Fh	R/W	Bit[3:0]: 0 to 15
RX_Advanced_Granularity_Capability	98h	07h	R/W	Bit[2:1]: Step size Bit[0]: Supports fine granularity steps
RX_Advanced_Hibern8Time_Capability	99h	04h	R/W	1–128
RX_Advanced_Min_ActivateTime_Capability	9Ah	0Bh	R/W	Bit[3:0]: 1–14

## UPIU Transaction Codes

Micron devices support the following UPIU transaction codes. For detailed information, refer to JEDEC UFS specification.



## 32GB, 64GB, 128GB, 256GB: Automotive UFS Memory UPIU Transaction Codes

**Table 9: UPIU Transaction Codes**

<b>Initiator to Target</b>	<b>Transaction Code</b>	<b>Target to Initiator</b>	<b>Transaction Code</b>
NOP OUT	00h	NOP IN	20h
COMMAND	01h	RESPONSE	21h
DATA OUT	02h	DATA IN	22h
TASK MANAGEMENT REQUEST	04h	TASK MANAGEMENT RESPONSE	24h
Reserved	11h	READY TO TRANSFER	31h
QUERY REQUEST	16h	QUERY RESPONSE	36h



## UFS Descriptors

Descriptors are blocks or pages of parameters that describe something about the device. Descriptors are classified into types: device descriptors, configuration descriptors, unit descriptors and so forth. Micron devices support the following UFS descriptors. For detailed information, refer to the JEDEC UFS specification.

**Table 10: Descriptor Identification Values**

Descriptor Type	Descriptor IDN
Device	00h
Configuration	01h
Unit	02h
Reserved	03h
Interconnect	04h
String	05h
Reserved	06h
Geometry	07h
Power	08h
Reserved	09h...FFh

**Table 11: Configuration Descriptor**

Offset	Size	Name	Default Value	Description
00h	1	bLength	90h	Size of this descriptor
01h	1	bDescriptorIDN	01h	Configuration descriptor type identifier
02h	1	bConfDescContinue	00h	00h: This value indicates that this is the last configuration descriptor in a sequence of write descriptor query requests. Device shall perform internal configuration based on received configuration descriptor(s). 01h: This value indicates that this is not the last configuration descriptor in a sequence of write descriptor query requests. Other configuration descriptors will be sent by host. Therefore the device should not perform the internal configuration yet.
03h	1	bBootEnable	00h	Enables to boot feature.
04h	1	bDescrAccessEn	00h	Enables access to the device descriptor after the partial initialization phase of the boot sequence.
05h	1	bInitPowerMode	01h	Configures the power mode after device initialization or hardware reset.
06h	1	bHighPriorityLUN	7Fh	Configures the high priority logical unit.
07h	1	bSecureRemovalType	00h	Configures the secure removal type.
08h	1	bInitActiveICCLLevel	00h	Configures the I <sub>CC</sub> level in active mode after device initialization or hardware reset.
09h	2	wPeriodicRTCUpdate	00h	Frequency and method of real-time clock update (see Device Descriptor).



**Table 11: Configuration Descriptor (Continued)**

Offset	Size	Name	Default Value	Description
0Bh	1	Reserved	–	
0Ch	1	bRPMBRegionEnable	00h	RPMB Region Enable Configures which RPMB regions are enabled in RPMB well known logical unit.
0Dh	1	bRPMBRegion1Size	00h	RPMB Region 1 Size Configures the size of RPMB region 1 if RPMB region 1 is enabled.
0Eh	1	bRPMBRegion2Size	00h	RPMB Region 2 Size Configures the size of RPMB region 2 if RPMB region 2 is enabled.
0Fh	1	bRPMBRegion3Size	00h	RPMB Region 3 Size Configures the size of RPMB region 3 if RPMB region 3 is enabled.

**Table 12: Device Descriptor**

Offset	Size	Name	Default Value	Description
00h	1	bLength	40h	Size of this descriptor
01h	1	bDescriptorIDN	00h	Device descriptor type identifier
02h	1	bDevice	00h	Device type: 00h Others: Reserved
03h	1	bDeviceClass	00h	UFS device class: Mass storage: 00h
04h	1	bDeviceSubClass	00h	UFS mass storage subclass: Bits (0/1) specify as follows: Bit 0: Bootable/non-bootable Bit 1: Embedded/removable Bit 2: Reserved (for unified memory extension specification) Others: Reserved
05h	1	bProtocol	00h	Protocol supported by UFS device: SCSI: 00h
06h	1	bNumberLU	00h	Number of logical units (user configurable): bNumberLU does not include well known logical units.
07h	1	bNumberWLU	04h	Number of well known logical units
08h	1	bBootEnable	00h	Boot enable indicates whether the device is enabled for boot (user configurable): 00h: Boot feature disabled 01h: Bootable feature enabled
09h	1	bDescrAccessEN	00h	Descriptor access enable indicates whether the device descriptor can be read after the partial initialization phase of the boot sequence (user configurable): 00h: Device descriptor access disabled 01h: Device descriptor access enabled

**Table 12: Device Descriptor (Continued)**

Offset	Size	Name	Default Value	Description
0Ah	1	bInitPowerMode	01h	Initial power mode defines the power mode after device initialization or hardware reset (user configurable): 00h: UFS-sleep mode 01h: Active mode
0Bh	1	bHighPriorityLUN	7Fh	High priority LUN defines the high priority logical unit (user configurable): Valid values are from 0 to the number of logical units specified by bMaxNumberLU, and 7Fh. If the value is 7Fh, all logical units have the same priority.
0Ch	1	bSecureRemovalType	00h	Secure removal type (user configurable): 00h: Information removed by an erase of the physical memory 01h: Information removed by overwriting the addressed locations with a single character followed by an erase 02h: Information removed by overwriting the addressed locations with a character, its complement, then a random character 03h: Information removed using a vendor define mechanism Others: Reserved
0Dh	1	bSecurityLU	01h	Support for security LU: 00h: Not supported 01h: RPMB Others: Reserved
0Eh	1	bBackgroundOpsTermLat	05h	Background operations termination latency defines the maximum latency for the termination of ongoing background operations. When the device receives a COMMAND UPIU with a transfer request, the device shall start the data transfer and send a DATA IN UPIU or an RTT UPIU within the latency declared in bBackgroundOpsTermLat. The latency is expressed in units of 10ms (for example, 01h = 10ms, FFh = 2550ms). The latency is undefined if the value of this parameter is 0.
0Fh	1	bInitActiveICCLLevel	00h	Initial active I <sub>CC</sub> level defines the bActiveICCLLevel value after power-on or reset (user configurable): Valid range from 00h to 0Fh
10h	2	wSpecVersion	0210h	Specification version: Bits[15:8] = major version in BCD format Bits[7:4] = minor version in BCD format Bits[3:0] = version suffix in BCD format Example: 3.21 = 0321h
12h	2	wManufactureDate	–	Manufacturing date: BCD version of the device manufacturing date Example: August 2010 = 0810h
14h	1	iManufactureName	00h	Manufacturer name: Index to the string which contains the manufacturer name



## 32GB, 64GB, 128GB, 256GB: Automotive UFS Memory UFS Descriptors

**Table 12: Device Descriptor (Continued)**

Offset	Size	Name	Default Value	Description
15h	1	iProductName	01h	Product name: Index to the string which contains the product name
16h	1	iSerialNumber	02h	Serial number: Index to the string which contains the serial number
17h	1	iOEMID	03h	OEM ID: Index to the string which contains the OEM ID
18h	2	wManufactureID	12Ch	Manufacturer ID: Manufacturer ID as defined in JEDEC standard JEP106 "Standard Manufacturer's Identification Code"
1Ah	1	bUD0BaseOffset	10h	Unit descriptor 0 base offset
1Bh	1	bUDConfigPLength	10h	Unit descriptor configuration parameter length: Total size of the configurable unit descriptor parameters
1Ch	1	bDeviceRTTCap	02h	RTT capability of device: Maximum number of outstanding RTTs supported by device. The minimum value is 2.
1Dh	2	wPeriodicRTCUpdate	0000h	Frequency and method of real-time clock update (user configurable): Bits[15:10]: Reserved Bit[9]: TIME_BASELINE 0h: Time elapsed from the previous dSecondsPassed update 1h: Absolute time elapsed from January 1st 2010 00:00 NOTE if the host device has a real-time clock it should use TIME BASELINE = 1. If the host device has no real-time clock it should use TIME BASELINE = 0. Bits[8:6]: TIME_UNIT 000b = Undefined 001b = Months 010b = Weeks 011b = Days 100b = Hours 101b = Minutes 110b = Reserved 111b = Reserved Bits[5:0]: TIME_PERIOD If TIME_UNIT is 0, TIME_PERIOD is ignored and the period between RTC update is not defined. All fields are configurable by the host.



**32GB, 64GB, 128GB, 256GB: Automotive UFS Memory  
UFS Descriptors**

**Table 12: Device Descriptor (Continued)**

Offset	Size	Name	Default Value	Description	
1Fh	1	bUFSFeaturesSupport	7Fh	UFS features support: This field indicates which features are supported by the device. A feature is supported if the related bit is set to 1. Bit[0]: Field firmware update (FFU) Bit[1]: Production state awareness (PSA) Bit[2]: Device life span Bit[3]: REFRESH operation (FFU) Bit[4]:TOO_HIGH_TEMPERATURE Bit[5]:TOO_LOW_TEMPERATURE Bit[6]: Extended temperature Others: Reserved Bit 0 shall be set to 1.	
20h	1	bFFUTimeout	0Ah	Field firmware update timeout: The maximum time, in seconds, that access to the device is limited or not possible through any ports associated due to execution of a WRITE BUFFER command. A value of 0 indicates that no timeout is provided.	
21h	1	bQueueDepth	20h	Queue depth: 0: The device implements the per-LU queuing architecture 1.. 255: The device implements the shared queuing architecture. This parameter indicates the depth of the shared queue. If bLUQueueDepth > 0 for any LU (except RPMB LU), then bQueueDepth shall be 0.	
22h	2	wDeviceVersion	–	Device version: This field provides the device version.	
24h	1	bNumSecureWPArea	20h	Number of secure write protect areas: This value specifies the total number of secure write protect areas supported by the device. The value shall be equal to or greater than bNumberLU and shall not exceed 32 (bNumberLU ≤ bNumSecureWPArea ≤ 32).	
25h	4	dPSAMaxDataSize	32GB	27BD55h	PSA maximum data size: This parameter specifies the maximum amount of data that may be written during the pre-soldering phase of the PSA flow. The value indicates the total amount of data for all logical units with bPSASensitive = 01h. Value expressed in units of 4KB.
			64GB	4F7AAAh	
			128GB	9EED55h	
			256GB	13DD2AAh	



**Table 12: Device Descriptor (Continued)**

Offset	Size	Name	Default Value	Description
29h	1	bPSAStateTimeout	12h	PSA state timeout: This parameter specifies the command maximum timeout for a change in bPSAState state. 00h means undefined. Otherwise, the formula to calculate the maximum timeout value is: Production state timeout = $100\mu\text{s} \times 2^{\text{bPSAStateTimeout}}$ For example: 01h means $100\mu\text{s} \times 2^1 = 200\mu\text{s}$ 02h means $100\mu\text{s} \times 2^2 = 400\mu\text{s}$ 17h means $100\mu\text{s} \times 2^{23} = 838.86\text{s}$ .
2Ah	1	iProductRevisionLevel	04h	Product revision level: Index to the string which contains the product revision level
2Bh	5	Reserved	–	Reserved
30h	16	Reserved	–	Reserved for Unified Memory Extension specification

Note: 1. Some fields are user configurable as they can be configured by the user writing the configuration descriptor.

**Table 13: Geometry Descriptor**

Offset	Size	Name	Default Value	Description	
00h	1	bLength	48h	Size of this descriptor	
01h	1	bDescriptorIDN	07h	Geometry descriptor type identifier	
02h	1	bMediaTechnology	00h	Reserved	
03h	1	Reserved	00h	Reserved	
04h	8	qTotalRawDevice-Capacity	32GB	3B9C000h	Total raw device capacity: Total memory quantity available to the user to configure the device logical units (RPMB excluded). It is expressed in unit of 512 bytes.
			64GB	7738000h	
			128GB	EE64000h	
			256GB	1DCBC000h	
0Ch	1	bMaxNumberLU	01h	Maximum number of logical unit supported by the UFS device: 01h: 32 logical units	
0Dh	4	dSegmentSize	2000h	Segment size: Value expressed in unit of 512 bytes	
11h	1	bAllocationUnitSize	01h	Allocation unit size: Value expressed in number of segments. Each logical unit can be allocated as a multiple of allocation units.	
12h	1	bMinAddrBlockSize	08h	Minimum addressable block size: Value expressed in unit of 512 bytes. Its minimum value is 08h, which corresponds to 4KB.	

**Table 13: Geometry Descriptor (Continued)**

Offset	Size	Name	Default Value	Description
13h	1	bOptimalReadBlockSize	40h	Optimal read block size: Value expressed in unit of 512 bytes. This is optional parameter, 0 = not available.
14h	1	bOptimalWriteBlockSize	40h	Optimal write block size: Value expressed in unit of 512 bytes
15h	1	bMaxInBufferSize	40h	Maximum data-in buffer size: Value expressed in unit of 512 bytes. Its minimum value is 08h, which corresponds to 4KB.
16h	1	bMaxOutBufferSize	40h	Maximum data-out buffer size: Value expressed in unit of 512 bytes. Its minimum value is 08h, which corresponds to 4KB.
17h	1	bRPMB_ReadWriteSize	20h	Maximum number of RPMB frames (256-byte of data) allowed in security protocol in and security protocol out (for example, associated with a single command UPIU). If the data to be transferred is larger than bRPMB_ReadWriteSize x 256 bytes, the host will transfer it using multiple SECURITY PROTOCOL IN/OUT commands.
18h	1	bDynamicCapacityResource Policy	01h	Dynamic capacity resource policy: This parameter specifies the device spare blocks resource management policy. 00h: Spare blocks resource management policy is per logical unit. The host should release amount of logical blocks from each logical unit as asked by the device. 01h: Spare blocks resource management policy is per memory type. The host may deallocate the required amount of logical blocks from any logical units with the same bMemoryType.
19h	1	bDataOrdering	00h	Support for out-of-order data transfer: 00h: Out-of-order data transfer is not supported by the device, in-order data transfer is required. 01h: Out-of-order data transfer is supported by the device. Others: Reserved
1Ah	1	bMaxContextIDNumber	20h	Maximum available number of contexts which are supported by the device: Minimum number of supported contexts shall be 5.
1Bh	1	bSysDataTagUnitSize	00h	bSysDataTagUnitSize provides system data tag unit size, which can be calculated as in the following (in bytes): Tag unit size = $2^{(bSysDataTagUnitSize)} \times bMinAddrBlock\ Size \times 512$
1Ch	1	bSysDataTagResSize	06h	Maximum storage area size in bytes allocated by the device to handle system data by the tagging mechanism: Valid range from 0 to 6

**Table 13: Geometry Descriptor (Continued)**

Offset	Size	Name	Default Value	Description
1Dh	1	bSupportedSecRTypes	09h	Bit map which represents the supported secure removal types: Bit 0: Information removed by an erase of the physical memory Bit 1: Information removed by overwriting the addressed locations with a single character followed by an erase Bit 2: Information removed by overwriting the addressed locations with a character, its complement, then a random character. Bit 3: Information removed using a vendor define mechanism Others: Reserved A value of 1 means that the corresponding secure removal type is supported.
1Eh	2	wSupportedMemoryTypes	8009h	Bit map which represents the supported memory types: Bit 0: normal memory type Bit 1: System code memory type Bit 2: Non-persistent memory type Bit 3: Enhanced memory type 1 Bit 4: Enhanced memory type 2 Bit 5: Enhanced memory type 3 Bit 6: Enhanced memory type 4 Bit 7: Reserved ... Bit 14: Reserved Bit 15: RPMB memory type A value 1 means that the corresponding memory type is supported. Bit 0 and Bit 15 shall be 1 for all UFS device.
20h	4	dSystemCodeMaxNAllocU	0h	Maximum number of allocation units for the system code memory type: Maximum available quantity of system code memory type for the entire device. Value expressed in number of allocation unit.
24h	2	wSystemCodeCapAdjFac	0h	Capacity adjustment factor for the system code memory type: This parameter is the ratio between the capacity obtained with the normal memory type and the capacity obtained with the system code memory type for the same amount of allocation units. CapacityAdjFactor = CapacityNormalMem/CapacitySystemCode wSystemCodeCapAdjFac = INTEGER(256 × CapacityAdjFactor)

**Table 13: Geometry Descriptor (Continued)**

Offset	Size	Name	Default Value	Description	
26h	4	dNonPersistMaxNAllocU	0h	Maximum number of allocation units for the non-persistent memory type: Maximum available quantity of non-persistent memory type for the entire device. Value expressed in number of allocation unit.	
2Ah	2	wNonPersistCapAdjFac	0h	Capacity adjustment factor for the non-persistent memory type: This parameter is the ratio between the capacity obtained with the normal memory type and the capacity obtained with the non-persistent memory type for the same amount of allocation units. $CapacityAdjFactor = CapacityNormalMem / CapacityNonPersist$ $wNonPersistCapAdjFac = INTEGER(256 \times CapacityAdjFactor)$	
2Ch	4	dEnhanced1MaxNAllocU	32GB	1DCEh	Maximum number of allocation units for the enhanced memory type 1
			64GB	3B9Ch	
			128GB	7732h	
			256GB	EE5Eh	
30h	2	wEnhanced1CapAdjFac	0300h	Capacity adjustment factor for the enhanced memory type 1	
32h	4	dEnhanced2MaxNAllocU	00000000h	Maximum number of allocation units for the enhanced memory type 2: Maximum available quantity of enhanced memory type 2 for the entire device Value expressed in number of allocation unit.	
36h	2	wEnhanced2CapAdjFac	0h	Capacity adjustment factor for the enhanced memory type 2: This parameter is the ratio between the capacity obtained with the normal memory type and the capacity obtained with the enhanced memory type 2 for the same amount of allocation units. $CapacityAdjFactor = CapacityNormalMem / CapacityEnhanced2$ $wEnhanced2CapAdjFac = INTEGER(256 \times CapacityAdjFactor)$ .	
38h	4	dEnhanced3MaxNAllocU	0h	Maximum number of allocation units for the enhanced memory type 3: Maximum available quantity of enhanced memory type 3 for the entire device Value expressed in number of allocation unit.	



**Table 13: Geometry Descriptor (Continued)**

Offset	Size	Name	Default Value	Description
3Ch	2	wEnhanced2CapAdjFac	0h	Capacity adjustment factor for the enhanced memory type 3: This parameter is the ratio between the capacity obtained with the normal memory type and the capacity obtained with the enhanced memory type 3 for the same amount of allocation units. $CapacityAdjFactor = CapacityNormalMem / CapacityEnhanced3$ $wEnhanced3CapAdjFac = INTEGER(256 \times CapacityAdjFactor)$ .
3Eh	4	dEnhanced4MaxNAllocU	0h	Maximum number of allocation units for the enhanced memory type 4: Maximum available quantity of enhanced memory type 4 for the entire device Value expressed in number of Allocation Unit.
42h	2	wEnhanced4CapAdjFac	0h	Capacity adjustment factor for the enhanced memory type 4: This parameter is the ratio between the capacity obtained with the normal memory type and the capacity obtained with the enhanced memory type 4 for the same amount of allocation units. $CapacityAdjFactor = CapacityNormalMem / CapacityEnhanced4$ $wEnhanced4CapAdjFac = INTEGER(256 \times CapacityAdjFactor)$ .
44h	2	dOptimalLogicalBlockSize	0h	Optimal logical block size: Bit [3:0]: Normal memory type Bit [7:4]: System code memory type Bit [11: 8]: Non-persistent memory type Bit [15:12]: Enhanced memory type 1 Bit [19:16]: Enhanced memory type 2 Bit [23:20]: Enhanced memory type 3 Bit [27:24]: Enhanced memory type 4 Bit [31:28]:Reserved The optimal logical block size for each memory type can be calculated from the related dOptimalLogicalBlockSize field as indicated in the following: Optimal logical block size = $2^{\wedge} (dOptimalLogicalBlockSize \text{ field}) \times bMinAddrBlockSize \times 512 \text{ byte}$ .

**Table 14: Unit Descriptor**

Offset	Size	Name	Value	Description
00h	1	bLength	23h	Size of this descriptor

**Table 14: Unit Descriptor (Continued)**

Offset	Size	Name	Value	Description
01h	1	bDescriptorIDN	02h	Unit descriptor type identifier
02h	1	bUnitIndex	00h to 1Fh	Unit index
03h	1	bLUEnable	00h	Logical unit enable (user configurable): 00h: Logical unit disabled 01h: Logical unit enabled Others: Reserved
04h	1	bBootLunID	00h	Boot LUN ID (user configurable): 00h: Not bootable 01h: Boot LU A 02h: Boot LU B Others: Reserved
05h	1	BLUWriteProtect	00h	Logical unit write protect (user configurable): 00h: LU not write protected 01h: LU write protected when fPowerOnWPEn = 1 02h: LU permanently write protected when fPermanentWPEn = 1 03h: Reserved (for UFS Security Extension specification) Others: Reserved
06h	1	bLUQueueDepth	00h	Logical unit queue depth: Queue depth available in this LU. Queue depth of 0 means best effort by device to service the command task.
07h	1	bPSASensitive	01h	00h: LU is not sensitive to soldering 01h: LU is sensitive to soldering Others: Reserved
08h	1	bMemoryType	00h	Memory type defines the logical unit memory type (user configurable): 00h: Normal memory 01h: System code memory type 02h: Non-persistent memory type 03h: Enhanced memory type 1 04h: Enhanced memory type 2 05h: Enhanced memory type 3 06h: Enhanced memory type 4 Others: Reserved
09h	1	bDataReliability	00h	Data reliability (user configurable): 00h: The logical unit is not protected. Logical unit's entire data might be lost as a result of a power failure during a WRITE operation. 01h: The logical unit is protected. Logical unit's data is protected against power failure. Others: Reserved
0Ah	1	bLogicalBlockSize	0Ch	Logical block size (user configurable): 0Ch (minimum value which corresponds to 4KB)–0Fh
0Bh	8	qLogicalBlockCount	00h	Logical block count (user configurable): Total number of addressable logical blocks in the LU in logical block size unit

**Table 14: Unit Descriptor (Continued)**

Offset	Size	Name	Value	Description
13h	4	dEraseBlockSize	00h	Erase block size: In number of logical blocks
17h	1	bProvisioningType	00h	Provisioning type (user configurable): 00h: Thin provisioning is disabled. (default) 02h: Thin provisioning is enabled and TPRZ = 0. 03h: Thin provisioning is enabled and TPRZ = 1. Others: Reserved
18h:1Fh	8	qPhyMemResource-Count	00h	Physical memory resource count: Total physical memory resource available in the logical unit
20h	2	wContextCapabilities	00h	(User configurable) Bits[3:0]: MaxContextID is the maximum amount of contexts that the LU supports simultaneously. The sum of all MaxContextID must not exceed bMaxContextIDNumber. Bits[6:4]: LARGE_UNIT_MAX_MULTIPLIER_M1 Bits[15:7]: Reserved
22h	1	bLargeUnitGranularity_M1	00h	Granularity of the large unit, minus 1: Large unit granularity = 1MB (bLargeUnitGranularity_M1 + 1)

Note: 1. Some fields are user configurable as they can be configured by the user writing the configuration descriptor.

**Table 15: RPMB Unit Descriptor**

Offset	Size	Name	Value	Description
00h	1	bLength	23h	Size of this descriptor
01h	1	bDescriptorIDN	02h	Unit descriptor type identifier
02h	1	bUnitIndex	C4h	Unit index
03h	1	bLUEnable	01h	Logical unit enable 01h: Logical unit enabled.
04h	1	bBootLunID	00h	Boot LUN ID 00h: Not bootable.
05h	1	bLUWriteProtect	00h	Logical unit write protect 00h: LU not write protected.
06h	1	bLUQueueDepth	00h	Logical unit queue depth: 0: RPMB LU queue not available (shared queuing is used) 1: Queue depth available in RPMB LU. Only 1 task may be queued at any given time
07h	1	bPSASensitive	01h	00h: LU is not sensitive to soldering 01h: LU is sensitive to soldering Others: Reserved
08h	1	bMemoryType	0Fh	Memory type 0Fh: RPMB memory type

**Table 15: RPMB Unit Descriptor (Continued)**

Offset	Size	Name	Value	Description
09h	1	bRPMBRegionEnable	0h	RPMB region enable: Bit 0: Don't care. RPMB region 0 is always enabled independent of this bit value. Bit 1: If set to 1, RPMB region 1 is enabled. Bit 2: If set to 1, RPMB region 2 is enabled. Bit 3: If set to 1, RPMB region 3 is enabled. Bit 4 to Bit 7: Reserved.
0Ah	1	bLogicalBlockSize	08h	Logical block size The size of addressable logical blocks is equal to the result of exponentiation with as base the number two and as exponent the bLogicalBlockSize value: $2^{(bLogicalBlockSize)}$ (for example, bLogicalBlockSize = 08h corresponds to 256 byte logical block size)
0Bh	8	qLogicalBlockCount	10000h	Logical block count
13h	4	dEraseBlockSize	00h	Erase block size
17h	1	bProvisioningType	00h	Provisioning type
18h:1Fh	8	qPhyMemResource-Count	10000h	Physical memory resource count
20h: 22h	3	Reserved	0h	Reserved

**Table 16: Power Parameters Descriptor**

Offset	Size	Name	Value	Description
00h	1	bLength	62h	Size of this descriptor
01h	1	bDescriptorIDN	08h	Power parameters descriptor type identifier
02h	2	wActiveICCLevelsVCC[0]	82BCh	Maximum $V_{CC}$ current value for bActiveICCLLevel = 0
04h	2	wActiveICCLevelsVCC[1]	82BCh	Maximum $V_{CC}$ current value for bActiveICCLLevel = 1
...	...	...	...	...
20h	2	wActiveICCLevelsVCC[15]	82BCh	Maximum $V_{CC}$ current value for bActiveICCLLevel = 15
22h	2	wActiveICCLevelsVCCQ[0]	0h	Maximum $V_{CCQ}$ current value for bActiveICCLLevel = 0
24h	2	wActiveICCLevelsVCCQ[1]	0h	Maximum $V_{CCQ}$ current value for bActiveICCLLevel = 1
...	...	...	...	...
40h	2	wActiveICCLevelsVCCQ[15]	0h	Maximum $V_{CCQ}$ current value for bActiveICCLLevel = 15
42h	2	wActiveICCLevelsVCCQ2[0]	82BCh	Maximum $V_{CCQ2}$ current value for bActiveICCLLevel = 0

**Table 16: Power Parameters Descriptor (Continued)**

Offset	Size	Name	Value	Description
44h	2	wActiveICCLevelsVCCQ2[1]	82BCh	Maximum $V_{CCQ2}$ current value for bActiveICCLLevel = 1
...	...	...	...	...
60h	2	wActiveICCLevelsVCCQ2[15]	82BCh	Maximum $V_{CCQ2}$ current value for bActiveICCLLevel = 15

**Table 17: Interconnect Descriptor**

Offset	Name	Value	Description
00h	bLength	06h	Size of this descriptor
01h	bDescriptorIDN	04h	Interconnect descriptor type identifier
02h	bcdUniproVersion	0160h	MIPI UniPro version number in BCD format (for example, version 3.21 = 0321h)
04h	bcdMphyVersion	0300h	MIPI M-PHY version number in BCD format (for example, version 3.21 = 0321h)

**Table 18: Manufacturer Name String Descriptor**

Offset	Size	Name	Value	Description
00h	1	bLength	12h	Size of this descriptor
01h	1	bDescriptorIDN	05h	String descriptor type identifier
02h	2	UC[0]	004Dh	Unicode string character
04h	2	UC[1]	0049h	Unicode string character
06h	2	UC[2]	0043h	Unicode string character
08h	2	UC[3]	0052h	Unicode string character
0Ah	2	UC[4]	004Fh	Unicode string character
0Ch	2	UC[5]	004Eh	Unicode string character
0Eh	2	UC[6]	0020h	Unicode string character
10h	2	UC[7]	0020h	Unicode string character

**Table 19: Product Name String Descriptor**

Offset	Size	Name	Value	Description
00h	1	bLength	22h	Size of this descriptor
01h	1	bDescriptorIDN	05h	String descriptor type identifier



**Table 19: Product Name String Descriptor (Continued)**

Offset	Size	Name		Value	Description
02h	2	UC[0]	32GB	004Dh	Unicode string character
			64GB	004Dh	
			128GB	004Dh	
			256GB	004Dh	
04h	2	UC[1]	32GB	0054h	Unicode string character
			64GB	0054h	
			128GB	0054h	
			256GB	0054h	
06h	2	UC[2]	32GB	0030h	Unicode string character
			64GB	0030h	
			128GB	0031h	
			256GB	0032h	
08h	2	UC[3]	32GB	0033h	Unicode string character
			64GB	0036h	
			128GB	0032h	
			256GB	0035h	
0Ah	2	UC[4]	32GB	0032h	Unicode string character
			64GB	0034h	
			128GB	0038h	
			256GB	0036h	
0Ch	2	UC[5]	32GB	0047h	Unicode string character
			64GB	0047h	
			128GB	0047h	
			256GB	0047h	
0Eh	2	UC[6]	32GB	0041h	Unicode string character
			64GB	0041h	
			128GB	0041h	
			256GB	0041h	
10h	2	UC[7]	32GB	0053h	Unicode string character
			64GB	0053h	
			128GB	0053h	
			256GB	0053h	
12h	2	UC[8]	32GB	0041h	Unicode string character
			64GB	0041h	
			128GB	0041h	
			256GB	0041h	

**Table 19: Product Name String Descriptor (Continued)**

Offset	Size	Name	Value	Description	
14h	2	UC[9]	32GB	004Fh	Unicode string character
			64GB	004Fh	
			128GB	004Fh	
			256GB	004Fh	
16h	2	UC[10]	32GB	0031h	Unicode string character
			64GB	0032h	
			128GB	0034h	
			256GB	0038h	
18h	2	UC[11]	32GB	0055h	Unicode string character
			64GB	0055h	
			128GB	0055h	
			256GB	0055h	
1Ah	2	UC[12]	32GB	0032h	Unicode string character
			64GB	0032h	
			128GB	0032h	
			256GB	0032h	
1Ch	2	UC[13]	32GB	0031h	Unicode string character
			64GB	0031h	
			128GB	0031h	
			256GB	0031h	
1Eh: 20h	4	UC[14]–UC[15]	0020h	Unicode string character	

**Table 20: OEM ID String Descriptor**

Offset	Size	Name	Value	Description
00h	1	bLength	0Eh	Size of this descriptor
01h	1	bDescriptorIDN	05h	String descriptor type identifier
02h	2	UC[0]	004Dh	Unicode string character
04h	2	UC[1]	0049h	Unicode string character
06h	2	UC[2]	0043h	Unicode string character
08h	2	UC[3]	0052h	Unicode string character
0Ah	2	UC[4]	004Fh	Unicode string character
0Ch	2	UC[5]	004Eh	Unicode string character

**Table 21: Serial Number String Descriptor**

Offset	Size	Name	Value	Description
00h	1	bLength	12h	Size of this descriptor
01h	1	bDescriptorIDN	05h	String descriptor type identifier
02h	2	UC[0]	–	Unicode string character
04h	2	UC[1]	–	Unicode string character
06h	2	UC[2]	–	Unicode string character
08h	2	UC[3]	–	Unicode string character
0Ah	2	UC[4]	–	Unicode string character
0Ch	2	UC[5]	–	Unicode string character
0Eh	2	UC[6]	–	Unicode string character
10h	2	UC[7]	–	Unicode string character

- Notes:
1. Each device is created with a unique identification number provided in UC[0] and UC[1] fields.
  2. UC[2] to UC[7] field values are Don't Care.

**Table 22: Product Revision Level String Descriptor**

Offset	Size	Name	Value	Description
00h	1	bLength	0Ah	Size of this descriptor
01h	1	bDescriptorIDN	05h	String descriptor type identifier
02h	2	UC[0]	–	Unicode string character
04h	2	UC[1]	–	Unicode string character
06h	2	UC[2]	–	Unicode string character
08h	2	UC[3]	–	Unicode string character

**Table 23: Device Health Descriptor**

Offset	Size	Name	Value	Description
00h	1	bLength	25h	Size of this descriptor
01h	1	bDescriptorIDN	09h	Device health descriptor type identifier
02h	1	bPreEOLInfo	01h	Pre end-of-life information provides indication about device life time reflected by average reserved blocks: 01h: Normal
03h	1	bDeviceLifeTimeEstA	01h	This field provides an indication of the device life time based on the amount of performed PROGRAM/ERASE cycles. The calculation method is vendor specific and referred as method A. 01h: 0%–10% device life time used
04h	1	bDeviceLifeTimeEstB	01h	This field provides an indication of the device life time based on the amount of performed PROGRAM/ERASE cycles. The calculation method is vendor specific and referred as method B. 00h: Information not available





## 32GB, 64GB, 128GB, 256GB: Automotive UFS Memory UFS Flags, Attributes, and Commands

**Table 23: Device Health Descriptor (Continued)**

Offset	Size	Name	Value	Description
05h	32	VendorPropInfo	00h	Reserved for vendor proprietary health report
25h	4	dRefreshTotalCount	00h	Total refresh count: Indicate how many times the device complete refresh for the entire device. Incremented by 1 when dRefreshProgress reach 100000 (100.000%).
29h	4	dRefreshProgress	00h	Refresh progress: Indicate the refresh progress in percentage (%). dRefreshProgress indicates 0.000%~100.000% in dec. dRefreshProgress = 100000 (dec) when it completes 100.000%. dRefreshProgress = 1000 (dec) when it completes 1.000%. When this value reaches 100000 (100.000%) 1. Device stops refreshing even if it did not complete the number of units specified by bRefreshUnit 2. dRefreshProgress shall be reset to 0 3. dRefreshTotalCount shall be incremented by 1 When bRefreshMethod = 02h (Manual-selective), even though some of physical blocks are not refreshed by device choice, dRefreshProgress should be incremented just as much as bRefreshUnit.

Note: 1. Micron offers proprietary solution for additional health status information.

## UFS Flags, Attributes, and Commands

A flag is a single boolean value that represents 0 or 1 type of value. Flags are useful to enable or disable certain functions, modes, or states with the device.

**Table 24: Flags**

IDN	Name	Type	Default Value	Description
00h	Reserved	–	–	Reserved
01h	fDeviceInit	Read/Set only	00h	Device initialization: 0b: Device initialization completed or not started yet 1b: Device initialization in progress
02h	fPermanentWPEn	Read/Write once	00h	Permanent write protection enable: 00h: Permanent write protection disabled 01h: Permanent write protection enabled
03h	fPowerOnWPEn	Read/Power on reset	00h	Power-on write protection enable: 00h: Power-on write protection disabled 01h: Power-on write protection enabled
04h	FBackgroundOpsEn	Read/Volatile	01h	Background operations enable: 00h: Device is not permitted to run background operations 01h: Device is permitted to run background operations



## 32GB, 64GB, 128GB, 256GB: Automotive UFS Memory UFS Flags, Attributes, and Commands

**Table 24: Flags (Continued)**

IDN	Name	Type	Default Value	Description
05h	fDeviceLifeSpan-ModeEn	Read/Volatile	00h	Device life span mode: 0b: Device life span mode is disabled 1b: Device life span mode is enabled
06h	fPurgeEnable	Write only/Volatile	00h	PURGE enable: 00h: PURGE operation is disabled 01h: PURGE operation is enabled
07h	fRefreshEnable	Write only/Volatile	00h	Refresh enable 0b: REFRESH operation is disabled. 1b: REFRESH operation is enabled. This flag shall only be set when the command queue of all logical units are empty and the bRefreshStatus is 00h (idle). fRefreshEnable is automatically cleared by the UFS device when the operation completes or an error condition occurs. fRefreshEnable can be cleared by the host to interrupt an ongoing REFRESH operation
08h	fPhyResourceRemoval	Read/Persistent	00h	Physical resource removal: The host sets this flag to 1 to indicate that the dynamic capacity operation commences upon device End-PointReset or hardware reset. The device resets this flag to 0 after completion of dynamic capacity operation. The host cannot reset this flag.
09h	fBusyRTC	Read only	00h	Busy real-time clock: 00h: Device is not executing internal operation related to RTC 01h: Device is executing internal operation related to RTC
0Ah	Reserved	–	–	Reserved for unified memory extension standard.
0Bh	fPermanentlyDisableFWUpdate	Read/Write once	00h	Permanently disable firmware update: 00h: The UFS device firmware may be modified. 01h: The UFS device permanently disallows future firmware updates to the UFS device.
0Ch	Reserved	–	–	Reserved for unified memory extension standard.
0Dh	Reserved	–	–	Reserved for unified memory extension standard.

All the flags reported in the table are device level flags. They are addressed setting IN-DEX = 00h and SELECTOR = 00h.

An attribute is a parameter that represents a specific range of numeric values that can be written or read. Attribute size can be from 1-bit to 32-bit. Attributes of the same type can be organized in arrays, each element of them identified by an index.



## 32GB, 64GB, 128GB, 256GB: Automotive UFS Memory UFS Flags, Attributes, and Commands

**Table 25: Attributes**

IDN	Name	Type	Size (Byte)	Default Value	Description
00h	bBootLunEN	Read/Persistent	1	00h	Boot LUN enable: 00h: Boot disabled 01h: Enabled boot from boot LU A 02h: Enabled boot from boot LU B All others: Reserved
01h	Reserved	–	–	–	Reserved
02h	bCurrentPowerMode	Read only	1	11h	Current power mode: 00h: Idle mode 10h: Pre-active mode 11h: Active mode 20h: Pre-sleep mode 22h: UFS-sleep mode 30h: Pre-power down mode 33h: UFS-power down mode Others: Reserved
03h	bActiveICCLLevel	Read/Volatile	1	00h	Active I <sub>CC</sub> level: bActiveICCLLevel defines the maximum current consumption allowed during active mode. 00h: Lowest active I <sub>CC</sub> level 0Fh: Highest active I <sub>CC</sub> level Others: Reserved
04h	bOutOfOrderDataEn	Read/Write once	1	00h	Out-of-order data transfer enable: 00h: Out-of-order data transfer is disabled 01h: Out-of-order data transfer is enabled Others: Reserved
05h	bBackgroundOpStatus	Read only	1	00h	Background operations status device health status for background operation: 00h: Not required 01h: Required, not critical 02h: Required, performance impact 03h: Critical Others: Reserved
06h	bPurgeStatus	Read only	1	00h	PURGE operation status: 00h: Idle (PURGE operation disabled) 01h: PURGE operation in progress 02h: PURGE operation stopped prematurely 03h: PURGE operation completed successfully 04h: PURGE operation failed due to logical unit queue not empty 05h: PURGE operation general failure Others: Reserved
07h	bMaxDataInSize	Read/Persistent	1	40h	Maximum data in size



## 32GB, 64GB, 128GB, 256GB: Automotive UFS Memory UFS Flags, Attributes, and Commands

**Table 25: Attributes (Continued)**

IDN	Name	Type	Size (Byte)	Default Value	Description
08h	bMaxDataOutSize	Read/Persistent	1	40h	Maximum data out size
09h	dDynCapNeeded	Read only	4	00h	Dynamic capacity needed
0Ah	bRefClkFreq	Read/Persistent	1	01h	Reference clock frequency value: 00h: 19.2 MHz 01h: 26 MHz 02h: 38.4 MHz 03h: 52 MHz Others: Reserved
0Bh	bConfigDescrLock	Read/Write once	1	00h	Configuration descriptor lock: 00h: Configuration descriptor not locked 01h: Configuration descriptor locked Others: Reserved
0Ch	bMaxNumOfRTT	Read/Persistent	1	02h	Maximum current number of outstanding RTTs in device that is allowed.
0Dh	wExceptionEventControl	Read/Volatile	2	00h	Exception event control: Bit 0: DYNCAP_EVENT_EN Bit 1: SYSPPOOL_EVENT_EN Bit 2: URGENT_BKOPS_EN Bit 3–15: Reserved
0Eh	wExceptionEventStatus	Read only	2	00h	Bit 0: DYNCAP_NEEDED Bit 1: SYSPPOOL_EXHAUSTED Bit 2: URGENT_BKOPS Bit 3–15: Reserved
0Fh	dSecondsPassed	Write only	4	00h	Bits[31:0]: Seconds passed from TIME BASELINE
10h	wContextConf	Read/Volatile	2	00h	INDEX specifies the LU number. SELECTOR specifies the context ID within the LU. Valid values are 01h–Fh.
11h	Obsolete	–	–	–	–
12h	Reserved	–	–	–	Reserved for Unified Memory Extension standard.
13h	Reserved	–	–	–	Reserved for Unified Memory Extension standard.
14h	bDeviceFFUStatus	Read only	1	00h	Device FFU status: 00h: No information 01h: Successful microcode update 02h: Microcode corruption error 03h: Internal error 04h: Microcode version mismatch 05h–FEh: Reserved FFh: General error



## 32GB, 64GB, 128GB, 256GB: Automotive UFS Memory UFS Flags, Attributes, and Commands

**Table 25: Attributes (Continued)**

IDN	Name	Type	Size (Byte)	Default Value	Description
15h	bPSAState	Read/Persistent	1	00h	00h: Off. PSA feature is off. 01h: Pre-soldering. PSA feature is on, device is in the pre-soldering state. 02h: Loading complete. PSA feature is on. The host will set to this value after the host finished writing data during pre-soldering state. 03h: Soldered. PSA feature is no longer available. Set by the device to indicate it is in post-soldering state. This attribute unchangeable after it is in soldered state.
16h	dPSADataSize	Read/Persistent	4	00h	The amount of data that the host plans to load to all logical units with bPSASensitive set to 1.
18h	bDeviceCaseRoughTemperature	Read only	1	00h	Device's rough package case surface temperature. This value shall be valid when (TOO_HIGH_TEMPERATURE is supported and TOO_HIGH_TEMP_EN is enabled) or (TOO_LOW_TEMPERATURE is supported and TOO_LOW_TEMP_EN is enabled). 0: Unknown temperature 1~250: (this value - 80) degrees in Celsius (i.e., -79°C~170°C) Others: Reserved
19h	bDeviceTooHighTemp-Boundary	Read only	1	BCh	High temperature boundary from which TOO_HIGH_TEMP in wExceptionEventStatus is turned on. 0: Unknown 100~250: (this value - 80) degrees in Celsius (i.e., 20°C~170°C) Others: Reserved
1Ah	bDeviceTooLowTemp-Boundary	Read only	1	2Bh	Low temperature boundary from which TOO_LOW_TEMP in wExceptionEventStatus is turned on. 0: Unknown 1~80: (this value - 80) degrees in Celsius (i.e., -79°C~0°C) Others: Reserved
1Bh	Reserved	–	-	–	–
...	Reserved	–	-	–	–
2Bh	Reserved	–	-	–	–



## 32GB, 64GB, 128GB, 256GB: Automotive UFS Memory UFS Flags, Attributes, and Commands

**Table 25: Attributes (Continued)**

IDN	Name	Type	Size (Byte)	Default Value	Description
2Ch	bRefreshStatus	Read only	1	00h	REFRESH operation status: 00h: Idle (REFRESH operation disabled) 01h: REFRESH operation in progress 02h: REFRESH operation stopped prematurely 03h: REFRESH operation completed successfully 04h: REFRESH operation failed due to logical unit queue not empty 05h: REFRESH operation general failure Others: Reserved When the bRefreshStatus is equal to the values 02h, 03h, 04h, or 05h, the bRefreshStatus is automatically cleared to 00h (idle) the first time that it is read.
2Dh	bRefreshFreq	Read/Persistent	1	00h	Refresh frequency: Host should make sure that dRefreshTotalCount will be incremented on this frequency. 00h: Not defined 01h: 1 month 02h: 2 month ... Fh: 255 month.
2Eh	bRefreshUnit	Read/Persistent	1	00h	REFRESH operation unit: This attribute may be set to adjust the minimum physical block numbers to be refreshed upon a single request (for example, fRefreshEnable set to 1) 00h: Minimum refresh capability of device 01h: 100.000% (for example, entire device) Others: Reserved



## 32GB, 64GB, 128GB, 256GB: Automotive UFS Memory UFS Flags, Attributes, and Commands

**Table 25: Attributes (Continued)**

IDN	Name	Type	Size (Byte)	Default Value	Description
2Fh	bRefreshMethod	Read/REFRESH Persistent	1	00h	Refresh method: This parameter specifies the REFRESH operation method. 00h : Not defined 01h: Manual-force. The device is obliged to refresh the amount of physical blocks as requested by the host, regardless whether these blocks need refresh or not. The REFRESH command refreshes the amount of physical blocks given in bRefreshUnit. Refresh starts at the next physical block from where it stopped (or the first block if refresh was never triggered before). 02h: Manual-selective. The REFRESH command refreshes the amount of physical blocks given in bRefreshUnit. Refresh starts at the next physical block from where it stopped (or the first block if refresh was never triggered before). The device only refreshes the blocks that it considers to be in need of refresh. Regardless of the actually refreshed blocks, dRefreshProgress is increased by bRefreshUnit once the REFRESH command is completed. Others: Reserved .

- Notes: 1. dDynCapNeeded and wContextConf are arrays of attributes.  
2. Default value means attribute's value after device manufacturing.

**Table 26: SCSI Commands**

Command Name	Opcode	Command Name	Opcode
FORMAT UNIT	04h	SECURITY PROTOCOL IN	A2h
INQUIRY	12h	SECURITY PROTOCOL OUT	B5h
MODE SELECT (10)	55h	SEND DIAGNOSTIC	1Dh
MODE SENSE (10)	5Ah	START STOP UNIT	1Bh
PREFETCH (10)	34h	SYNCHRONIZE CACHE (10)	35h
PREFETCH (16)	90h	SYNCHRONIZE CACHE (16)	91h
READ (6)	08h	TEST UNIT READY	00h
READ (10)	28h	UNMAP	42h
READ (16)	88h	VERIFY (10)	2Fh
READ BUFFER	3Ch	WRITE (6)	0Ah
READ CAPACITY (10)	25h	WRITE (10)	2Ah



**32GB, 64GB, 128GB, 256GB: Automotive UFS Memory  
UFS Flags, Attributes, and Commands**

**Table 26: SCSI Commands (Continued)**

Command Name	Opcode	Command Name	Opcode
READ CAPACITY(16)	9Eh	WRITE (16)	8Ah
REPORT LUNS	A0h	WRITE BUFFER	3Bh
REQUEST SENSE	03h	–	–





## UFS Supported Pages

Micron devices support the following UFS mode pages. For detailed information, refer to the JEDEC UFS specification.

**Table 27: UFS Supported Pages**

Page Name	Page Code	Subpage Code	Description
Control	0Ah	00h	Return control mode page
Read-write error recovery	01h	00h	Return read-write error recovery mode page
Caching	08h	00h	Return caching mode page
All pages	3Fh	00h	Return all mode pages (not including subpages)
All subpages	3Fh	FFh	Return all mode pages and subpages

**Table 28: Control Mode Page**

Offset	Bit	Field	Default Value	Description
00h	5:0	PAGE CODE	0Ah	Indicates the format and parameters for particular mode page.
00h	6	SPF	0h	Indicates SUBPAGE format.
00h	7	PS	01h	Indicates the page parameters can be saved.
01h	7:0	PAGE LENGTH	0Ah	Indicates the size in bytes of the following mode page parameters.
02h	0	RLEC	0h	Report log exception condition. Setting this bit to 0 specifies that the device server shall not report log exception conditions.
02h	1	GLTSD	0h	Global logging target save disable (GLTSD): Setting this bit to 0 specifies that the logical unit implicitly saves, at vendor specific intervals, each log parameter in which the TSD bit is set to 0.
02h	2	D_SENSE	0h	A descriptor format sense data (D_SENSE) bit set to 0 specifies that the device server shall return fixed format sense data when returning sense data in the same I_T_L_Q nexus transaction as the status.
02h	3	DPICZ	0h	A disable protection information check if protect field is 0 (DPICZ) bit set to 0 indicates that checking of protection information bytes is enabled.
02h	4	TMF_ONLY	0h	The allow task management functions only (TMF_ONLY) bit set to 0 specifies that the device server shall process commands with the auto contingent allegiance (ACA) task attribute received on the faulted I_T nexus when an ACA condition has been established.
02h	7:5	TST	0h	Indicates task set type (TST).
03h	0	Obsolete	0h	Not available

**Table 28: Control Mode Page (Continued)**

Offset	Bit	Field	Default Value	Description
03h	2:1	QERR	0h	The queue error management (QERR) field specifies how the device server shall handle other commands when one command is terminated with check condition status. If an ACA condition is established, the affected commands in the task set shall resume after the ACA condition is cleared. Otherwise, all commands other than the command that received the check condition status shall be processed as if no error occurred.
03h	3	NUAR	0h	No unit attention on release (NUAR) bit set to 0 specifies that the device server shall establish a unit attention condition.
03h	7:4	QUEUE ALGORITHM MODIFIER	01h	A value of 1 in this field specifies that the device server may reorder the processing sequence of commands having the SIMPLE task attribute in any manner.
04h	2:0	Obsolete	0h	Not available
04h	3	SWP	0h	A software write protect (SWP) bit (user configurable)
04h	5:4	UA_INTLCK_CTRL	0h	The unit attention interlocks control (UA_INTLCK_CTRL) field set to 00b specifies that the logical unit shall clear any unit attention condition reported in the same I_T_L_Q nexus transaction as a check condition status and shall not establish a unit attention condition when a command is completed with busy, task set full, or reservation conflict status.
04h	6	RAC	0h	A report a check (RAC) bit set to 0 specifies that the device server may return busy status regardless of the length of time the reason for returning busy status may persist.
04h	7	VS	0h	Not available
05h	2:0	AUTOLOAD MODE	0h	This field specifies the action to be taken by a removable medium device server when a medium is inserted. Setting it to 0 means that medium shall be loaded for full access.
05h	3	Reserved	–	–
05h	4	RWWP	0h	A reject write without protection (RWWP) bit set to 0 specifies that WRITE commands without protection information shall be processed.
05h	5	ATMPE	0h	An application tag mode page enabled (ATMPE) bit set to 0 specifies that the application tag mode page is disabled and the contents of logical block application tags are not defined by this standard.
05h	6	TAS	0h	A task aborted status (TAS) bit set to 0 specifies that aborted commands shall be terminated by the device server without any response to the application client.
05h	7	ATO	0h	An application tag owner (ATO) bit set to 0 specifies that the device server may modify the contents of the LOGICAL BLOCK APPLICATION TAG field and, depending on the protection type, may modify the contents of the LOGICAL BLOCK REFERENCE TAG field.
06h	15:0	Obsolete	0h	Not available

**Table 28: Control Mode Page (Continued)**

Offset	Bit	Field	Default Value	Description
08h	15:0	BUSY TIMEOUT PERIOD	01h	Busy timeout period: 0001h = 100ms
0Ah	15:0	EXTENDED SELF-TEST COMPLETION TIME	0h	This field contains advisory data that is the time in seconds that the device server requires to complete an extended self-test when the device server is not interrupted by subsequent commands and no errors occur during processing of the self-test.

Note: 1. Some fields are user configurable.

**Table 29: Read – Write Error Recovery Mode Page**

Offset	Bit	Field	Default Value	Description
00h	5:0	PAGE CODE	01h	Indicates the format and parameters for particular mode page.
00h	6	SPF	0h	Indicates SUBPAGE format.
00h	7	PS	01h	Indicates the page parameters can be saved.
01h	7:0	PAGE LENGTH	0Ah	Indicates the size in bytes of the following mode page parameters.
02h	0	DCR	0h	A disable correction (DCR) bit set to 0 allows the use of additional information (for example, ECC bytes) for data error recovery. If the EER bit is set to 1, the DCR bit shall be set to 0.
02h	1	DTE	0h	A data terminate on error (DTE) bit set to 0 specifies that the device server shall not terminate the data-in or data-out buffer transfer of a command performing a READ or WRITE operation upon detection of a recovered error.
02h	2	PER	0h	A post error (PER) bit set to 0 specifies that if a recovered read error occurs during a command performing a READ or WRITE operation, then the device server shall perform error recovery procedures within the limits established by the error recovery parameters and only terminate the command with check condition status if the error becomes uncorrectable based on the established limits. If the DTE bit is set to 1, then the PER bit shall be set to 1.
02h	3	EER	0h	An enable early recovery (EER) bit set to 0 specifies that the device server shall use an error recovery procedure that minimizes the risk of error mis-detection or mis-correction.
02h	4	RC	0h	A read continuous (RC) bit set to 0 specifies that ERROR RECOVERY operations that cause delays during the data transfer are acceptable. Data shall not be fabricated.
02h	5	TB	0h	A transfer block (TB) bit set to 0 specifies that if an unrecovered read error occurs during a READ operation, then the device server shall not transfer any data for the logical block to the data-in buffer.

**Table 29: Read – Write Error Recovery Mode Page (Continued)**

Offset	Bit	Field	Default Value	Description
02h	6	ARRE	0h	An automatic read reassignment enabled (ARRE) bit set to 0 specifies that the device server shall not perform automatic reassignment of defective logical blocks during READ operations.
02h	7	AWRE	01h	An automatic write reassignment enabled (AWRE) bit set to 1 specifies that the device server shall enable automatic reassignment of defective logical blocks during WRITE operations.
03h	7:0	READ RETRY COUNT	01h	This field (user configurable) specifies the number of times that the device server shall attempt its recovery algorithm during READ operations.
04h	7:0	Obsolete	0h	Not available
05h	7:0	Obsolete	0h	Not available
06h	7:0	Obsolete	0h	Not available
07h	1:0	Restricted for MMC-6	0h	Not available
07h	6:2	Reserved	–	–
07h	7	TPERE	0h	Not available
08h	7:0	WRITE RETRY COUNT	00h	This field (user configurable) specifies the number of times that the device server shall attempt its recovery algorithm during WRITE operations.
09h	7:0	Reserved	–	–
0Ah	15:0	RECOVERY TIME LIMIT	4B0h	This field (user configurable) specifies in milliseconds the maximum time duration that the device server shall use for data error recovery procedures. When both a retry count and a recovery time limit are specified, the field that specifies the recovery action of least duration shall have priority.

**Table 30: Caching Mode Page**

Offset	Bit	Field	Default Value	Description
00h	5:0	PAGE CODE	08h	Indicates the format and parameters for particular mode page.
00h	6	SPF	0h	Indicates SUBPAGE format.
00h	7	PS	01h	Indicates the page parameters can be saved.
01h	7:0	PAGE LENGTH	12h	Indicates the size in bytes of the following mode page parameters.
02h	0	RCD	0h	A read cache disable (RCD) bit (user configurable) set to 0 specifies that the device server may return data requested by a READ command by accessing either the cache or medium. A RCD bit set to 1 specifies that the device server shall transfer all of the data requested by a READ command from the medium (for example, data shall not be transferred from the cache).

**Table 30: Caching Mode Page (Continued)**

Offset	Bit	Field	Default Value	Description
02h	1	MF	0h	A multiplication factor (MF) bit set to 0 specifies that the device server shall interpret the MINIMUM PREFETCH field and the MAXIMUM PREFETCH field in terms of the number of logical blocks for each of the respective types of prefetch.
02h	2	WCE	01h	A write back cache enable (WCE) bit (user configurable) set to 0 specifies that the device server shall complete a WRITE command with good status only after writing all of the data to the medium without error. A WCE bit set to 1 specifies that the device server may complete a WRITE command with good status after receiving the data without error and prior to having written the data to the medium.
02h	3	SIZE	0h	A size enable (SIZE) bit set to 0 specifies that the NUMBER OF CACHE SEGMENTS field is used to control caching segmentation. Simultaneous use of both the number of segments and the segment size is vendor specific.
02h	4	DISC	0h	A discontinuity (DISC) bit set to 0 specifies that prefetches be truncated or wrapped at time discontinuities.
02h	5	CAP	0h	A caching analysis permitted (CAP) bit set to 0 specifies that caching analysis is disabled (for example, to reduce overhead time or to prevent non-pertinent operations from impacting tuning values).
02h	6	ABPF	0h	An abort prefetch (ABPF) bit set to 0 when the DRA bit set to 0 specifies that the termination of any active prefetch is dependent upon caching mode page bytes 4 through 11 and is vendor specific.
02h	7	IC	0h	An initiator control (IC) enable bit set to 0 specifies that the device server uses its own adaptive caching algorithm.
03h	3:0	WRITE RETENTION PRIORITY	0h	This field set to 0h means that the device server should not distinguish between retaining the indicated data and data placed into the cache by other means (for example, prefetch).
03h	7:4	DEMAND READ RETENTION PRIORITY	0h	This field set to 0 means that the device server should not distinguish between retaining the indicated data and data placed into the cache by other means (for example, prefetch).
04h	15:0	DISABLE PREFETCH TRANSFER LENGTH	0h	This field specifies the selective disabling of anticipatory prefetch on long transfer lengths. If this field is set to 0, then all anticipatory prefetching is disabled for any request for data, including those with a transfer length of 0.
06h	15:0	MINIMUM PREFETCH	0h	This field specifies the number of logical blocks to prefetch regardless of the delays it might cause in processing subsequent commands. If MF bit is set to 0, this field contains the number of logical blocks.
08h	15:0	MAXIMUM PREFETCH	0h	This field specifies the number of logical blocks to prefetch if the prefetch does not delay processing of subsequent commands. If MF bit is set to 0, this field contains the number of logical blocks.

**Table 30: Caching Mode Page (Continued)**

Offset	Bit	Field	Default Value	Description
0Ah	15:0	MAXIMUM PREFETCH CEILING	0h	This field specifies an upper limit on the number of logical blocks computed as the maximum prefetch. If this number of logical blocks is greater than the value in the MAXIMUM PREFETCH field, then the number of logical blocks to prefetch shall be truncated to the value stored in this field.
0Ch	0	NV_DIS	0h	An NV_DIS bit set to 0 specifies that the device server may use a nonvolatile cache and indicates that a nonvolatile cache may be present and enabled.
0Ch	2:1	Reserved	–	–
0Ch	4:3	Vendor specific	0h	Vendor specific
0Ch	5	DRA	0h	A disable read-ahead (DRA) bit set to 0 specifies that the device server may continue to read logical blocks into the prefetch buffer beyond the addressed logical block(s).
0Ch	6	LBCSS	0h	A logical block cache segment size (LBCSS) bit set to 0 specifies that the CACHE SEGMENT SIZE field units shall be interpreted as bytes. The LBCSS shall not impact the units of other fields.
0Ch	7	FSW	0h	A force sequential write (FSW) bit set to 0 specifies that the device server may reorder the sequence of writing logical blocks (for example, in order to achieve faster command completion).
0Dh	7:0	NUMBER OF CACHE SEGMENTS	0h	This field specifies the number of segments into which the device server shall divide the cache.
0Eh	15:0	CACHE SEGMENT SIZE	0h	This field specifies the segment size in bytes if the LBCSS bit is set to 0 or in logical blocks if the LBCSS bit is set to 1. This field is valid only when the SIZE bit is set to 1.
10h	7:0	Reserved	–	–
11h	15:0	Obsolete	0h	Not available

Note: 1. Some fields are user configurable.



## UFS Vital Product Data Parameters

The vital product data (VPD) pages are returned by an INQUIRY command with the EVPD bit set to 1 and contain vendor specific product information about a logical unit and SCSI target device. A UFS device supports the following VPD pages.

**Table 31: Supported VPD Pages**

Offset	Bit	Field	Default Value	Description
00h	4:0	PERIPHERAL DEVICE TYPE	1Eh	This bit set to 1 means device server is a direct access block device 1Eh: Well known logical unit
00h	7:5	PERIPHERAL QUALIFIER	0h	A peripheral device having the specified peripheral device type is connected to this logical unit. If the device server is unable to determine whether or not a peripheral device is connected, it also shall use this peripheral qualifier. This peripheral qualifier does not mean that the peripheral device connected to the logical unit is ready for access.
01h	7:0	PAGE CODE	0h	This field identifies the VPD page and contains the same value as in this field in the INQUIRY CDB.
02h	15:0	PAGE LENGTH	07h	This field indicates the length in bytes of the VPD parameters that follow this field.
04h	7:0	Supported VPD Page List[0]	0h	The supported VPD page list contains a list of all VPD page codes implemented by the logical unit in ascending order beginning with page code 00h: SUPPORTED_VPD_PAGE
05h	7:0	Supported VPD Page List[1]	80h	UNIT_SERIAL_NUM
06h	7:0	Supported VPD Page List[2]	83h	DEVICE_ID
07h	7:0	Supported VPD Page List[3]	87h	MODE_PAGE_POLICY
08h	7:0	Supported VPD Page List[4]	B0h	BLOCK_LIMITS
09h	7:0	Supported VPD Page List[5]	B1h	BLOCK_DEVICE_CHARACTERISTICS
0Ah	7:0	Supported VPD Page List[6]	B2h	LOGICAL_BLOCK_PROVISIONING

**Table 32: Unit Serial Number VPD Page**

Offset	Bit	Field	Default Value	Description
00h	4:0	PERIPHERAL DEVICE TYPE	1Eh	This bit set to 1 means device server is a direct access block device 1Eh: Well known logical unit



## 32GB, 64GB, 128GB, 256GB: Automotive UFS Memory UFS Vital Product Data Parameters

**Table 32: Unit Serial Number VPD Page (Continued)**

Offset	Bit	Field	Default Value	Description
00h	7:5	PERIPHERAL QUALIFIER	0h	A peripheral device having the specified peripheral device type is connected to this logical unit. If the device server is unable to determine whether or not a peripheral device is connected, it also shall use this peripheral qualifier. This peripheral qualifier does not mean that the peripheral device connected to the logical unit is ready for access.
01h	7:0	PAGE CODE	80h	This field identifies the VPD page and contains the same value as in this field in the INQUIRY CDB.
02h	15:0	PAGE LENGTH	4h	This field indicates the length in bytes of the VPD parameters that follow this field.
04h	7:0	PRODUCT SERIAL NUMBER	–	This field contains right-aligned ASCII data that is vendor-assigned serial number.

**Table 33: Device Identification VPD Page**

Offset	Bit	Field	Default Value	Description
00h	4:0	PERIPHERAL DEVICE TYPE	1Eh	This bit set to 1 means device server is a direct access block device 1Eh: Well known logical unit
00h	7:5	PERIPHERAL QUALIFIER	0h	A peripheral device having the specified peripheral device type is connected to this logical unit. If the device server is unable to determine whether or not a peripheral device is connected, it also shall use this peripheral qualifier. This peripheral qualifier does not mean that the peripheral device connected to the logical unit is ready for access.
01h	7:0	PAGE CODE	83h	This field identifies the VPD page and contains the same value as in this field in the INQUIRY CDB.
02h	15:0	PAGE LENGTH	Ch	This field indicates the length in bytes of the VPD parameters that follow this field.
04h	4:0	CODE SET	2h	This field contains a code set enumeration that indicates the format of the DESIGNATOR field.
04h	7:5	PROTOCOL IDENTIFIER	0h	This field may indicate the SCSI transport protocol to which the designation descriptor applies.
05h	3:0	DESIGNATOR TYPE	1h	This field indicates the format and assignment authority for the designator.
05h	5:4	ASSOCIATION	0h	This field indicates the entity with which the DESIGNATOR field is associated. If a logical unit returns a designation descriptor with this field set to 00b or 10b, it shall return the same descriptor when it is accessed through any other I_T nexus.
05h	6	Reserved	–	–
05h	7	PIV	0h	A protocol identifier valid (PIV) bit set to 0 indicates the PROTOCOL IDENTIFIER field contents are reserved.





## 32GB, 64GB, 128GB, 256GB: Automotive UFS Memory UFS Vital Product Data Parameters

**Table 33: Device Identification VPD Page (Continued)**

Offset	Bit	Field	Default Value	Description
06h	7:0	Reserved	–	–
07h	7:0	DESIGNATOR LENGTH	8h	This field indicates the length in bytes of the DESIGNATOR field.
08h	23:0	IEEE COMPANY ID	–	–
0Bh	39:0	VENDOR SPECIFIC EXTENSION IDENTIFIER	–	–

**Table 34: Mode Page Policy VPD Page**

Offset	Bit	Field	Default Value	Description
00h	4:0	PERIPHERAL DEVICE TYPE	1Eh	This bit set to 1 means device server is a direct access block device 1Eh: Well known logical unit
00h	7:5	PERIPHERAL QUALIFIER	0h	A peripheral device having the specified peripheral device type is connected to this logical unit. If the device server is unable to determine whether or not a peripheral device is connected, it also shall use this peripheral qualifier. This peripheral qualifier does not mean that the peripheral device connected to the logical unit is ready for access.
01h	7:0	PAGE CODE	87h	This field identifies the VPD page and contains the same value as in this field in the INQUIRY CDB.
02h	15:0	PAGE LENGTH	0Ch	This field indicates the length in bytes of the VPD parameters that follow this field.
Mode page policy descriptor [0]				Contains information describing the mode page policy for read-write error recovery mode page.
04h	5:0	Policy page code	1h	
04h	7:6	Reserved1	0h	
05h	7:0	Policy subpage code	0h	
06h	1:0	ModePagePolicy	0h	
06h	6:2	Reserved 2	0h	
06h	7	MLUS	1h	
07h	7:0	Reserved 3	0h	
Mode page policy descriptor [1]				Contains information describing the mode page policy for caching mode page.
08h	5:0	Policy page code	8h	
08h	7:6	Reserved1	0h	
09h	7:0	Policy subpage code	0h	
0Ah	1:0	Mode page policy	0h	
0Ah	6:2	Reserved 2	0h	
0Ah	7	MLUS	01h	
0Bh	7:0	Reserved 3	0h	



## 32GB, 64GB, 128GB, 256GB: Automotive UFS Memory UFS Vital Product Data Parameters

**Table 34: Mode Page Policy VPD Page (Continued)**

Offset	Bit	Field	Default Value	Description
Mode page policy descriptor [2]				Contains information describing the mode page policy for control mode page.
0Ch	5:0	Policy page code	Ah	
0Ch	7:6	Reserved 1	0h	
0Dh	7:0	Policy subpage code	0h	
0Eh	1:0	ModePagePolicy	0h	
0Eh	6:2	Reserved 2	0h	
0Eh	7	MLUS	0h	
0Fh	7:0	Reserved 3	0h	
Mode page policy descriptor [3]				Contains information describing the mode page policy for all mode pages.
10h	5:0	Policy page code	3Fh	
10h	7:6	Reserved1	0h	
11h	7:0	Policy subpage code	0h	
12h	1:0	ModePagePolicy	0h	
12h	6:2	Reserved 2	0h	
12h	7	MLUS	0h	
13h	7:0	Reserved 3	0h	
Mode page policy descriptor [4]				Contains information describing the mode page policy for all mode pages and subpages.
14h	5:0	Policy page code	3Fh	
14h	7:6	Reserved1	0h	
15h	7:0	Policy subpage code	FFh	
16h	1:0	ModePagePolicy	0h	
16h	6:2	Reserved 2	0h	
16h	7	MLUS	0h	
17h	7:0	Reserved 3	0h	

**Table 35: Block Limits VPD Page**

Offset	Bit	Field	Default Value	Description
00h	4:0	PERIPHERAL DEVICE TYPE	1Eh	This bit set to 1 means device server is a direct access block device 1Eh: Well known logical unit
00h	7:5	PERIPHERAL QUALIFIER	0h	A peripheral device having the specified peripheral device type is connected to this logical unit. If the device server is unable to determine whether or not a peripheral device is connected, it also shall use this peripheral qualifier. This peripheral qualifier does not mean that the peripheral device connected to the logical unit is ready for access.



## 32GB, 64GB, 128GB, 256GB: Automotive UFS Memory UFS Vital Product Data Parameters

**Table 35: Block Limits VPD Page (Continued)**

Offset	Bit	Field	Default Value	Description
01h	7:0	PAGE CODE	80h	This field identifies the VPD page and contains the same value as in this field in the INQUIRY CDB.
02h	15:0	PAGE LENGTH	3Ch	This field indicates the length in bytes of the VPD parameters that follow this field.
04h	7:0	Reserved	–	–
05h	7:0	MAXIMUM COMPARE AND WRITE LENGTH	0h	This field is set to 0, if the device server does not support this command.
06h	15:0	OPTIMAL TRANSFER LENGTH GRANULARITY	20h	This field indicates the optimal transfer length granularity in blocks for a single ORWRITE command, PREFETCH command, READ command, VERIFY command, WRITE command, WRITE AND VERIFY command, XDREAD command, XDWRITE command, XDWRITEREAD command, or XPWRITE command.
08h	31:0	MAXIMUM TRANSFER LENGTH	0h	This field indicates the maximum transfer length in blocks that the device server accepts for a single ORWRITE command, READ command, VERIFY command, WRITE command, WRITE AND VERIFY command, XDWRITEREAD command, or XPWRITE command.
0Ch	31:0	OPTIMAL TRANSFER LENGTH	20h	This field indicates the optimal transfer length in blocks for a single ORWRITE command, PREFETCH command, READ command, VERIFY command, WRITE command, WRITE AND VERIFY command, XDREAD command, XDWRITE command, XDWRITEREAD command, or XPWRITE command.
10h	31:0	MAXIMUM PREFETCH XDREAD XDWRITE TRANSFER LENGTH	100h	This field indicates: a) the maximum transfer length in blocks that the device server accepts for a single PREFETCH command b) if the XOR control mode page is implemented, then the maximum value supported by the MAXIMUM XOR WRITE SIZE field in the XOR control mode page. c) if the XOR control mode page is not implemented, then the maximum transfer length in blocks that the device server accepts for a single XDWRITE command or XDREAD command. The device server should set this field to less than or equal to the MAXIMUM TRANSFER LENGTH field.
14h	31:0	MAXIMUM UNMAP LBA COUNT	FFFFFFFFh	This field indicates the maximum number of LBAs that may be unmapped by an UNMAP command. If the number of LBAs that may be unmapped by an UNMAP command is constrained only by the amount of data that may be contained in the UNMAP parameter list, then the device server shall set this field to FFFF_FFFFh. If the device server implements the UNMAP command, then the value in this field shall be greater than or equal to 1.



## 32GB, 64GB, 128GB, 256GB: Automotive UFS Memory UFS Vital Product Data Parameters

**Table 35: Block Limits VPD Page (Continued)**

Offset	Bit	Field	Default Value	Description
18h	31:0	MAXIMUM UNMAP BLOCK DESCRIPTOR COUNT	1h	This field indicates the maximum number of unmap block descriptors that shall be contained in the parameter data transferred to the device server for an UNMAP command. If there is no limit on the number of unmap block descriptors contained in the parameter data, then the device server shall set this field to FFFF_FFFFh. If the device server implements the UNMAP command, then the value in this field shall be greater than or equal to 1.
1Ch	31:0	OPTIMAL UNMAP GRANULARITY	1h	This field indicates the optimal granularity in logical blocks for unmap requests. An unmap request with a number of logical blocks that is not a multiple of this value may result in UNMAP operations on fewer LBAs than requested. If this field is set to 0000_0000h, then the optimal unmap granularity is not specified.
20h	30:0	UNMAP GRANULARITY ALIGNMENT	0h	This field indicates the LBA of the first logical block to which the OPTIMAL UNMAP GRANULARITY field applies. The unmap granularity alignment is used to calculate an optimal unmap request starting LBA as follows: Optimal unmap request starting LBA = (n × OPTIMAL UNMAP GRANULARITY) + UNMAP GRANULARITY ALIGNMENT Where n is 0 or any positive integer value.
20h	31	UGAVALID	0h	An unmap granularity alignment valid (UGAVALID) bit set to 0 indicates that the UNMAP GRANULARITY ALIGNMENT field is not valid.

**Table 36: Block Device Characteristics**

Offset	Bit	Field	Default Value	Description
00h	4:0	PERIPHERAL DEVICE TYPE	1Eh	This bit set to 1 means device server is a direct access block device 1Eh: Well known logical unit
00h	7:5	PERIPHERAL QUALIFIER	000h	A peripheral device having the specified peripheral device type is connected to this logical unit. If the device server is unable to determine whether or not a peripheral device is connected, it also shall use this peripheral qualifier. This peripheral qualifier does not mean that the peripheral device connected to the logical unit is ready for access.
01h	7:0	PAGE CODE	B1h	This fields identifies the VPD page and contains the same value as in the PAGE CODE field in the INQUIRY CDB
02h	15:0	PAGE LENGTH	3Ch	This field indicates the length in bytes of the VPD parameters that follow this field.
04h	15:0	MEDIUM ROTATION RATE	0001h	0001h means device is a non-rotating medium (for example, solid state).



## 32GB, 64GB, 128GB, 256GB: Automotive UFS Memory UFS Vital Product Data Parameters

**Table 36: Block Device Characteristics (Continued)**

Offset	Bit	Field	Default Value	Description
06h	7:0	Reserved	–	–
07h	3:0	NOMINAL FORM FACTOR	05h	This field indicates the nominal form factor of the device containing the logical unit.
07h	7:4	Reserved	–	–

**Table 37: Logical Block Provisioning**

Offset	Bit	Field	Default Value	Description
00h	4:0	PERIPHERAL DEVICE TYPE	1Eh	This bit set to 1 means device server is a direct access block device 1Eh: Well known logical unit
00h	7:5	PERIPHERAL QUALIFIER	000h	A peripheral device having the specified peripheral device type is connected to this logical unit. If the device server is unable to determine whether or not a peripheral device is connected, it also shall use this peripheral qualifier. This peripheral qualifier does not mean that the peripheral device connected to the logical unit is ready for access.
01h	7:0	PAGE CODE	B2h	This fields identifies the VPD page and contains the same value as in the PAGE CODE field in the INQUIRY CDB
02h	15:0	PAGE LENGTH	04h	This field indicates the length in bytes of the VPD parameters that follow this field.
04h	7:0	THRESHOLD EXPONENT	16h	This field indicates the threshold set size in LBAs as a power of 2.
05h	0	DP	00h	A descriptor present (DP) bit set to 0 indicates that a PROVISIONING GROUP DESCRIPTOR is not present.
05h	1	ANC_SUP	00h	This bit set to 0 indicates that the device server does not support anchored LBAs.
05h	5:2	Reserved	–	–
05h	6	TBPWS	00h	This bit set to 0 indicates that the device server does not support the use of the WRITE SAME (16) command to unmap LBAs.
05h	7	TPU	01h	This bit set to 1 indicates that the device server supports the UN-MAP command.
06h	7:0	Reserved	–	–
07h	7:0	Reserved	–	–

When the EVPD bit is set to 0 and page code = 0, the standard INQUIRY DATA is responded to INQUIRY command. The standard INQUIRY DATA format is shown in the table below:



## 32GB, 64GB, 128GB, 256GB: Automotive UFS Memory UFS Vital Product Data Parameters

**Table 38: Standard Inquiry Data**

Offset	Bit	Field	Default Value	Description
00h	4:0	PERIPHERAL DEVICE TYPE	1Eh	This bit set to 1 means device server is a direct access block device 1Eh: Well known logical unit
00h	7:5	PERIPHERAL QUALIFIER	0h	A peripheral device having the specified peripheral device type is connected to this logical unit. If the device server is unable to determine whether or not a peripheral device is connected, it also shall use this peripheral qualifier. This peripheral qualifier does not mean that the peripheral device connected to the logical unit is ready for access.
01h	6:0	Reserved	–	–
01h	7	RMB	0h	A removable medium (RMB) bit set to 0 indicates that the medium is not removable.
02h	7:0	VERSION	6h	This field indicates the implemented version of this standard. This field set to 06h means the conformance to SPC.
03h	3:0	RESPONSE DATA FORMAT	2h	This field value of two indicates that the data shall be in the format defined in SPC.
03h	7:4	NA1	0h	Not available in UFS standard
04h	7:0	ADDITIONAL LENGTH	1Fh	This field indicates the length in bytes of the remaining standard INQUIRY data.
05h	7:0	NA2	0h	Not available in UFS standard
06h	7:0	NA3	0h	Not available in UFS standard
07h	0	NA4	0h	Not available in UFS standard
07h	1	CMDQUE	1h	This bit is set to 1 indicating that the logical unit supports the command management model (SAM).
07h	7:2	NA5	0h	Not available in UFS standard
08h	15:0	VENDOR IDENTIFICATION	–	This field contains left-aligned ASCII data identifying the vendor of the product.
10h	15:0	PRODUCT IDENTIFICATION	–	This field contains left-aligned ASCII data defined by the vendor.
20h	15:0	PRODUCT REVISION LEVEL	–	This field contains left-aligned ASCII data defined by the vendor.



## 32GB, 64GB, 128GB, 256GB: Automotive UFS Memory Electrical Specifications

### Electrical Specifications

According to JEDEC UFS v2.1 specification, power-up timing starts when the supply voltage crosses 300mV and ends when it reaches the minimum operating value. Micron device only supports  $V_{CC}$  and  $V_{CCQ2}$ .  $V_{CCQ}$  is not used.

**Table 39: Power Supply Parameters**

Parameter	Symbol	Min	Max	Unit
$V_{CC}$ operating range	$V_{CC}$	2.7	3.6	V
$V_{CCQ}$ operating range	$V_{CCQ}$	–	–	–
$V_{CCQ2}$ operating range	$V_{CCQ2}$	1.7	1.95	V
Supply power-up timing for 3.3V	$t_{PRUH}$	–	35	ms
Supply power-up timing for 1.8V	$t_{PRUL}$	–	25	ms
Supply power-up timing for 1.2V	$t_{PRUV}$	–	–	–

**Table 40: Reference Clock Parameters<sup>1</sup>**

Parameter	Symbol	Min	Max	Units
Frequency	$f_{ref}$		19.2 26 38.4 52	MHz
Frequency error	$f_{ERROR}$	–150	+150	ppm
Clock rise time <sup>1</sup>	$t_{IRISE}$	–	2	ns
Clock fall time	$t_{IFALL}$	–	2	ns
Duty cycle	$t_{DC}$	45	55	%
Phase noise	N	–	–66	dBc
Noise floor density	Ndensity	–	–140	dBc/Hz
Input impedance	$RL_{RX}$	100	–	k $\Omega$
	$CL_{RX}$	–	5	pF

Note: 1.  $V_{IL}$  parameter is 0.2V on RST\_n and REF\_CLK signals.



## Revision History

### Rev.G – 05/20

- Added note to packaging information explaining proprietary nature of Ni/Au-plated test pads.
- Updated Ordering Information table; removed part numbers with package code TD.
- Updated Sleep current values

### Rev.F – 12/19

- Updated Legal Status to Production
- Updated Ordering Information table: Added note for ES
- Updated Active Current Consumption table and Lower-Power Mode table in UFS Performance and Current Consumption section
- Updated Configuration Descriptor table in UFS Descriptors section
- Updated Mode Page Policy VPD Page table in UFS Vital Product Data Parameters section
- Added Note in package dimensions section

### Rev. E – 10/19

- Added package code TD with NC balls to facilitate PCB routing
- Added note to Recommended Capacitor Values table in Architecture: VDDiQ capacitor is optional
- Updated note of Performance table in UFS Performance and Current Consumption
- Added note to Recommended Capacitor Values table in Architecture: VDDiQ capacitor is optional
- Added note to Device Health Descriptor table in UFS Descriptors

### Rev. D – 06/19

- Added JEDEC/UFS specification version 3.0 in Features
- Updated UFS Performance and Current Consumption section
- Updated Device, Geometry, RPMB Unit, Power Parameters, and Product Name String Descriptors values

### Rev. C – 02/19

- Updated legal status to Preliminary
- Added AAT temperature ranges and MPNs
- Updated Performance and Current Consumption values
- Changed dPSAMaxDataSize, bUFSFeaturesSupport, and bRefClkFreq values

### Rev. B – 11/18

- Changed applicable package

### Rev. A – 10/18

- Initial release





## 32GB, 64GB, 128GB, 256GB: Automotive UFS Memory Revision History

---

8000 S. Federal Way, P.O. Box 6, Boise, ID 83707-0006, Tel: 208-368-4000  
[www.micron.com/products/support](http://www.micron.com/products/support) Sales inquiries: 800-932-4992  
Micron and the Micron logo are trademarks of Micron Technology, Inc.  
All other trademarks are the property of their respective owners.

This data sheet contains minimum and maximum limits specified over the power supply and temperature range set forth herein.  
Although considered final, these specifications are subject to change, as further product development and data characterization some-  
times occur.