

Sicherheits-Einbaustecker
ID/S6AR-N-S
ID/S6AR-N-B4S

mit Arretierung und Gewindeanschluss

Sicherheits-Einbaustecker vom Typ ID/S6AR-N-S und ID/S6AR-N-B4S eignen sich als isolierte Stecker für den Einbau in Gehäuse und Frontplatten. Diese Stecker sind mit Buchsen KBT6AR-N zu kontaktieren. Die dabei entstehenden Steckverbindungen sind verriegelbar.

Der Stecker ID/S6AR-N-B4S kann mit Ø 4mm MC Sicherheitssteckern kontaktiert werden, da der Ø 6mm Stift mit Ø 4mm Bohrung ausgebildet ist.

Der interne Anschluss der Stecker erfolgt über Gewinde M6 mit Muttern und Scheiben.

Safety flush-mounting plugs
ID/S6AR-N-S
ID/S6AR-N-B4S

with snap-in lock and threaded stud

Model ID/S6AR-N-S and ID/S6AR-N-B4S safety flush-mounting plugs are insulated plugs designed for flush mounting in housings and panels. The plugs are designed to mate with sockets KBT6AR-N. The resulting plug connections are securable by means of snap-in lock.

The plug ID/S6AR-N-B4S also mates with Ø 4mm MC Safety plugs, because the Ø 6mm plug has a Ø 4mm socket hole.

The internal connection is made with an M6 threaded stud with nuts and washers.

Broches de sécurité à encastrer
ID/S6AR-N-S
ID/S6AR-N-B4S

avec verrouillage et embout fileté

Les broches de sécurité à encastrer du type ID/S6AR-N-S et ID/S6AR-N-B4S sont des connecteurs isolés pour le montage dans des boîtiers et sur des panneaux. Ces broches doivent être connectées aux douilles KBT6AR-N. Les liaisons ainsi obtenues sont verrouillables. Il est possible de se connecter sur la prise du type ID/S6AR-N-B4S avec une fiche de sécurité Ø 4mm MC, puisque la broche centrale a un perçage de Ø 4mm.

Le câble, équipé d'une cosse, se raccorde sur un embout fileté M6 à l'aide d'écrous et de rondelles.



Montageanleitung MA038



Assembly instructions MA038



Instructions de montage MA038

ID/S6AR-N-S ¹⁾

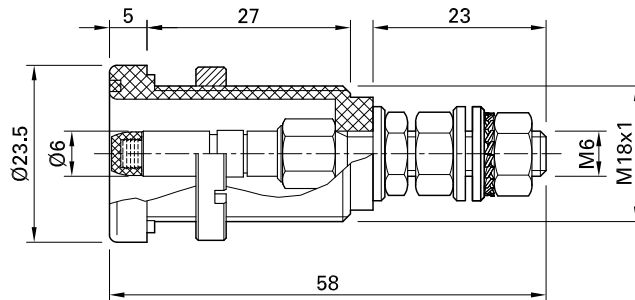

ID/S6AR-N-B4S

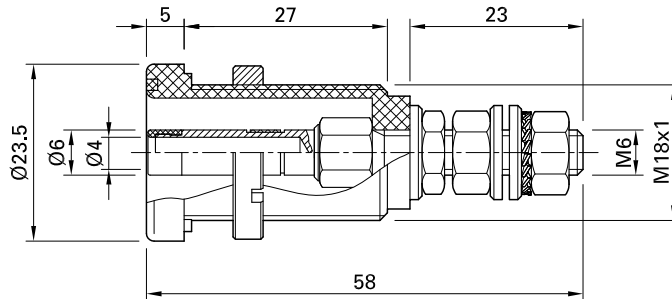

¹⁾ Auslaufmodell wird ersetzt durch die neue Version ID/S6AR-N-B4S mit alternativem Ø 4mm Abgriff.

¹⁾ Clearing model, this type will be replaced by the new version ID/S6AR-N-B4S with alternative Ø 4mm tapping connection.

¹⁾ Fin de série, cet article sera remplacé par le nouveau type ID/S6AR-N-B4S avec possibilité alternative de connexion de fiches Ø 4mm.



Montageschlüssel SS6 für die Mutter MUID und Bohrplan, siehe Seite 10



Socket spanner SS6 for nut MUID and drilling plan, see page 10



Clé de montage SS6 pour l'écrou MUID et plan de perçage, voir page 10

Technische Daten



Technical data



Caractéristiques techniques



Allgemeine Daten General data Données générales				Mechanische Daten Mechanical data Caractéristiques mécaniques							
Seite Page Page	Typ Type Type	Bestell Nr. Order No. No. de Cde	Farben ¹⁾ Colours ¹⁾ Couleurs ¹⁾	Anschluss Connection Raccordement	Leiterschnitt Cu Conductor cross-section Section du conducteur	Nenn-Ø Stift / Buchse Nom.-Ø pin / socket Ø-nom. Broche / douille	Auszugskraft Withdrawal force Force d'extraction	Steckkraft Insertion force Force d'embrochage	Max. Anzugsdrehmom. Max. tightening torque Couple maxi	Gewicht Weight Poids	Lamellentyp Multilam Type Type de lamelle
					mm ²	Ø mm	N	N	Nm	kg	
10	ID/B6AR-N-S	14.0010-*	20 – 29	Sa	–	6	25	30	3	0,044	LAIII
12	ID/B6AR-N/10-S	14.0013-*	20 – 29	P	10	6	25	30	3	0,035	LAIII
12	ID/B6AR-N/16-S	14.0014-*	20 – 29	P	16	6	25	30	3	0,034	LAIII
12	ID/B6AR-N/25-S	14.0017-*	20 – 29	P	25	6	25	30	3	0,036	LAIII
14	ID/S6AR-N-S	14.0004-*	20 – 29	Sa	25	6	–	–	–	0,035	–
14	ID/S6AR-N-B4S	14.0034-*	20 – 29	Sa	25	6 (4)	–	–	–	0,035	–
16	ID/S6NB	14.0006-*	20 – 29	Sa	25	6	–	–	–	0,032	–
17	ID/B6S	14.0000-*	20 – 29	Sa	–	6	–	–	–	0,045	–
18	AB6AR-S/9,4	14.0023-*	20 – 29	Sa	10	6	25	30	3	0,047	LAIII
18	AB6AR-S/12,4	14.0029-*	20 – 29	Sa	10	6	25	30	3	0,047	LAIII
20	AS6AR-S/9,4	14.0030-*	20 – 29	Sa	10	6 (4)	25	30	3	0,034	–
20	AS6AR-S/12,4	14.0033-*	20 – 29	Sa	10	6 (4)	25	30	3	0,034	–
22	IB6AR-N-S	14.2016-*	21 – 29	Sa	–	6	25	30	–	0,027	LAIII
23	BD6AR-N-S	14.1006		St	–	6	25	30	–	0,032	LAIII
23	VS6-50	14.1002		St	–	6	–	–	–	0,036	–
24	AZB6AR-N-S/6-4	14.1013		St	–	6/4	25	30	–	0,039	LAIII
25	AZS6AR-N/6-4	14.1012		St	–	6 (4)	25	30	–	0,054	LAIII
25	RS6AR/4S	14.1000	22	St	–	6/4	–	–	–	0,010	–
26	KBT6AR-N/10-S	15.0017-*	21 – 29	P	10	6	25	30	–	0,031	LAIII
26	KBT6AR-N/16-S	15.0020-*	21 – 29	P	16	6	25	30	–	0,031	LAIII
27	KBT6AR-N/25-S-L	15.0140-21		P	25	6	25	30	–	–	LAIII
28	KST6AR-N/10	15.0001-*	21 – 29	P	10	6	–	–	–	0,015	–
28	KST6AR-N/16	15.0002-*	21 – 29	P	16	6	–	–	–	0,016	–
29	KST6AR-N/25-L	15.0142-21		P	25	6	–	–	–	–	–
31	KST6N/10	15.0007-*	21 – 29	P	10	6	–	–	–	0,014	–
31	KST6/10F	15.0018-*	21 – 29	P	10	6	15	–	–	0,014	LAIII
31	KST6N/16	15.0008-*	21 – 29	P	16	6	–	–	–	0,015	–
31	KST6/16F	15.0019-*	21 – 29	P	16	6	15	–	–	0,015	LAIII
32	KBT6AR-W-N/10-S	15.0078-*	21 – 29	P	10	6	–	–	–	0,055	–
32	KBT6AR-W-N/16-S	15.0084-*	21 – 29	P	16	6	–	–	–	0,056	–
33	KBT6AR-W-N/25-S-L	15.0141-21		P	25	6	25	30	–	–	LAIII
34	KST6AR-W-N/10	15.0064-*	21 – 29	P	10	6	–	–	–	0,043	–
34	KST6AR-W-N/16	15.0074-*	21 – 29	P	16	6	–	–	–	0,044	–
35	KST6AR-W-N/25-L	15.0143-21		P	25	6	–	–	–	–	–

* = Farbcode

¹⁾ Farbcode siehe Seite 6

Sa = Schraubanschluss

P = Crimpanschluss

St = Steckanschluss

* = Colour code

¹⁾ Colour code see page 6

Sa = Screw terminal

P = Crimp connection

St = Plug-in connection

* = Code couleurs

¹⁾ Code couleurs voir page 6

Sa = Raccordement à visser

P = Fût à sertir

St = Raccordement à enficher

Allgemeine Daten General data Données générales				Elektrische Daten Electrical data Caractéristiques électriques					
Seite Page Page	Typ Type Type	Bestell Nr. Order No. No. de Cde	Farben ¹⁾ Couleurs ¹⁾ Couleurs ¹⁾	Bemessungsstrom Rated current Intensité assignée	Bemessungsspannung ²⁾ Rated voltage ²⁾ Tension assignée ²⁾	Kontaktwiderstand Contact resistance Résistance de contact	Kurzschlussstrom 1s Short-circuit current 1s Intensité de court-circuit 1s	Kurzschlussstrom 3s Short-circuit current 3s Intensité de court-circuit 3s	Stossstrom Surge current Intensité crête
				A	V	μΩ	kA	kA	kA
10	ID/B6AR-N-S	14.0010-*	20 – 29	100	600	160	1,2	0,7	8,0
12	ID/B6AR-N/10-S	14.0013-*	20 – 29	80	600	160	1,2	0,7	8,0
12	ID/B6AR-N/16-S	14.0014-*	20 – 29	100	600	160	2,0	1,2	8,0
12	ID/B6AR-N/25-S	14.0017-*	20 – 29	125	600	160	2,5	1,5	8,0
14	ID/S6AR-N-S	14.0004-*	20 – 29	125	600	–	1,2	0,7	8,0
14	ID/S6AR-N-B4S	14.0034-*	20 – 29	80	600	–	1,2	0,7	8,0
16	ID/S6NB	14.0006-*	20 – 29	125	600	–	1,2	0,7	8,0
17	ID/B6S	14.0000-*	20 – 29	80	600 ³⁾	160	1,2	0,7	8,0
18	AB6AR-S/9,4	14.0023-*	20 – 29	80	600	160	1,2	0,7	8,0
18	AB6AR-S/12,4	14.0029-*	20 – 29	80	600	160	1,2	0,7	8,0
20	AS6AR-S/9,4	14.0030-*	20 – 29	80	600	–	1,2	0,7	8,0
20	AS6AR-S/12,4	14.0033-*	20 – 29	80	600	–	1,2	0,7	8,0
22	IB6AR-N-S	14.2016-*	20 – 29	80	600 ³⁾	160	1,2	0,7	8,0
23	BD6AR-N-S	14.1006		80	600	160	–	–	–
23	VS6-50	14.1002		80	500 ³⁾	–	–	–	–
24	AZB6AR-N-S/6-4	14.1013		80	600 ³⁾	160	1,2	0,7	8,0
25	AZS6AR-N/6-4	14.1012		80	600 ³⁾	160	1,2	0,7	8,0
25	RS6AR/4S	14.1000	22	32	600 ³⁾	–	–	–	–
26	KBT6AR-N/10-S	15.0017-*	21 – 29	80	600	160	1,2	0,7	8,0
26	KBT6AR-N/16-S	15.0020-*	21 – 29	100	600	160	2,0	1,2	8,0
27	KBT6AR-N/25-S-L	15.0140-21		125	600	160	2,5	1,5	8,0
28	KST6AR-N/10	15.0001-*	21 – 29	80	600 ³⁾	–	1,2	0,7	8,0
28	KST6AR-N/16	15.0002-*	21 – 29	100	600 ³⁾	–	2,0	1,2	8,0
29	KST6AR-N/25-L	15.0142-21		125	600 ³⁾	–	2,5	1,5	8,0
31	KST6N/10	15.0007-*	21 – 29	80	600 ³⁾	–	1,2	0,7	8,0
31	KST6/10F	15.0018-*	21 – 29	80	600 ³⁾	160	1,2	0,8	8,0
31	KST6N/16	15.0008-*	21 – 29	100	600 ³⁾	–	2,0	1,2	8,0
31	KST6/16F	15.0019-*	21 – 29	100	600 ³⁾	160	2,0	1,2	8,0
32	KBT6AR-W-N/10-S	15.0078-*	21 – 29	80	600	160	1,2	0,7	8,0
32	KBT6AR-W-N/16-S	15.0084-*	21 – 29	100	600	160	2,0	1,2	8,0
33	KBT6AR-W-N/25-S-L	15.0141-21		125	600	160	2,5	1,5	8,0
34	KST6AR-W-N/10	15.0064-*	21 – 29	80	600 ³⁾	–	1,2	0,7	8,0
34	KST6AR-W-N/16	15.0074-*	21 – 29	100	600 ³⁾	–	2,0	1,2	8,0
35	KST6AR-W-N/25-L	15.0143-21		125	600 ³⁾	–	2,5	1,5	8,0

* = Farbcode

¹⁾ Farbcode siehe Seite 6²⁾ Nur in gestecktem Zustand³⁾ Während der Installation und/oder dem Stecken und Trennen muss der Anschluss spannungsfrei sein! Der Schutz gegen elektrischen Schlag muss durch das Endprodukt gegeben sein.

* = Colour code

¹⁾ Colour code see page 6²⁾ In the mated condition only!³⁾ During installation, connecting or disconnecting, the terminal must not be connected to the supply! Protection against electric shock has to be provided in the finished product.

* = Code couleurs

¹⁾ Code couleurs voir page 6²⁾ Seulement à l'état connecté!³⁾ Pendant l'installation et les phases d'embrochage ou débrochage, l'élément à raccorder ne doit pas être sous tension. La protection contre les chocs électriques doit être assurée par le produit fini, à l'état monté.