

DI5031

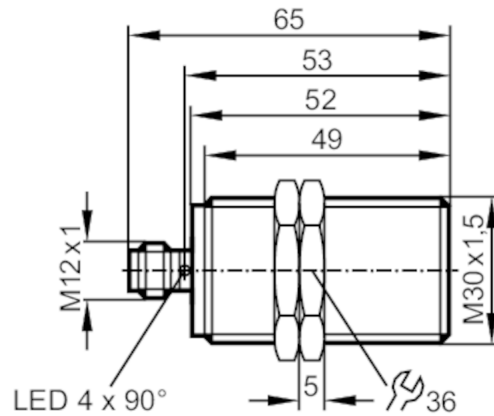

Compact evaluation unit for speed monitoring

DIK3012BWRKG/IO/US



Product characteristics	
Electrical design	PNP/NPN
Output function	normally open / normally closed; (parameterisable)
Sensing range [mm]	12
Communication interface	IO-Link
Housing	threaded type
Dimensions [mm]	M30 x 1.5 / L = 65
Application	
Application	simple evaluation of rotating and linear movement with regard to underspeed; blocking
Electrical data	
Nominal voltage DC [V]	10...30
Current consumption [mA]	< 10
Protection class	III
Reverse polarity protection	yes
Outputs	
Electrical design	PNP/NPN
Output function	normally open / normally closed; (parameterisable)
Max. voltage drop switching output DC [V]	2.5
Permanent current rating of switching output DC [mA]	100
Short-circuit proof	yes
Overload protection	yes
Detection zone	
Sensing range [mm]	12
Sensing range adjustable	no
Operating distance [mm]	0...9.72
Measuring/setting range	
Setting range [Imp/min]	5...14400

DI5031



Compact evaluation unit for speed monitoring

DIK3012BWRKG/IO/US

Accuracy / deviations		
Correction factor	steel: 1 / stainless steel: 0.7 / brass: 0.5 / aluminium: 0.4 / copper: 0.3	
Hysteresis [% of Sr]	10	
Response times		
Start-up delay [s]	0...30; (In steps of: 100 ms; Default: 15 s)	
Max. damping frequency [Imp/min]	18000	
Interfaces		
Communication interface	IO-Link	
Operating conditions		
Ambient temperature [°C]	-40...85	
Storage temperature [°C]	-25...85	
Protection	IP 66; IP 67; IP 68; IP 69K	
Tests / approvals		
EMC	EN 61000-4-2 ESD	4 kV CD / 8 kV AD
	EN 61000-4-3 HF radiated	10 V/m
	EN 61000-4-4 Burst	2 kV
	EN 61000-4-6 HF conducted	10 V
	EN 55011	class B
Shock resistance	EN 60947-5-2	
	EN 60068-2-27 Ea	100 g 11 ms half-sine; 3 shocks each in every direction of the 3 coordinate axes
Vibration resistance	DIN EN 60947-5-2	20 g (10...3000 Hz)
		50 sweep cycles per frequency; 1 octave per minute in 3 axes
MTTF [years]	664	
UL approval	UL Approval no.	A008
Mechanical data		
Weight [g]	121.5	
Housing	threaded type	
Mounting	flush mountable	
Dimensions [mm]	M30 x 1.5 / L = 65	
Thread designation	M30 x 1.5	
Materials	brass white bronze coated; sensing face: PBT orange; LED window: PEI; lock nuts: brass white bronze coated	
Tightening torque [Nm]	50	
Displays / operating elements		
Display	SIO mode	
	output stage supplied with current	4 x LED, yellow
	IO-Link mode	
	target in measuring range	4 x LED, yellow
	target outside measuring range	4 x LED, yellow flashing
Accessories		
Accessories (supplied)	lock nuts: 2	
Electrical connection		
Connector: 1 x M12		

DI5031



Compact evaluation unit for speed monitoring

DIK3012BWRKG/IO/US



Connection

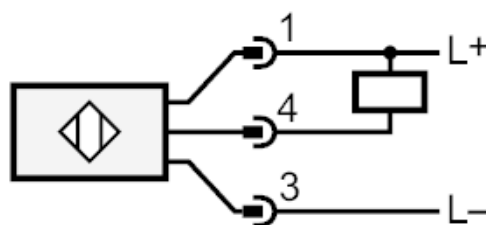
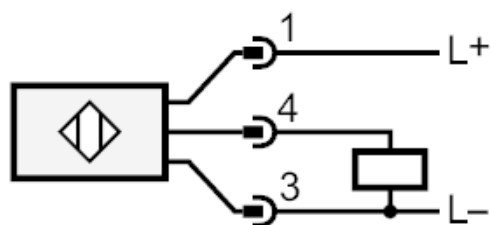

4: OUT / IO-Link