

# COMPRESSED AIR QUICK-FIT COUPLING SERIES IAC

The compressed air quick-fit coupling by Metal Work allows quick replacement of pneumatic equipment (drills, milling machines, screwers and actuators in general) without having to set the line pressure to zero each time. Rapid tool changeover can be easily obtained by fitting a female body on the branch under pressure and the male coupling on the actuator. The presence of a female coupling with a safety valve on the branch under pressure prevents air dispersion during disconnection.

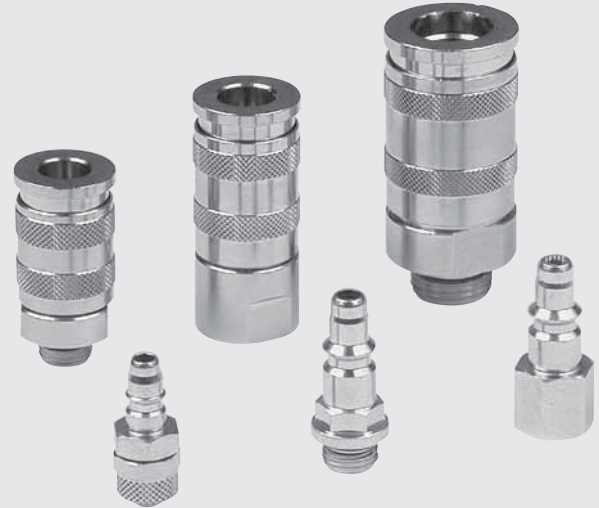

## TECHNICAL DATA

		MINI		100	200	300
Threaded coupling		1/8"	1/4"	1/4"	3/8"	1/2"
Maximum inlet pressure	MPa	3		3		
	bar	30		30		
	psi	435		435		
Flow rate at 6 bar (0.6 MPa - 87 psi) ΔP 1 bar (0.1 MPa - 14 psi)	l/min	480		750	1450	1750
Maximum temperature	°C	80		80		
	°F	176		176		

## COMPONENTS

- ① Body: nickel-plated brass
- ② Ring nut: nickel-plated brass
- ③ Valve: nickel-plated brass
- ④ Coupling: carbonitrided and zinc-plated steel
- ⑤ Ball: stainless steel
- ⑥ Ring nut spring: AISI 302
- ⑦ Valve spring: AISI 302

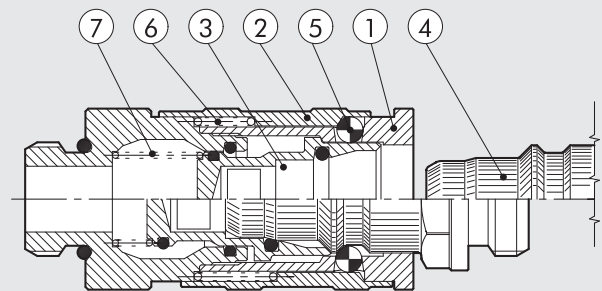

The actual male couplings don't have lateral holes. They cannot be coupled with the manual ports old production.

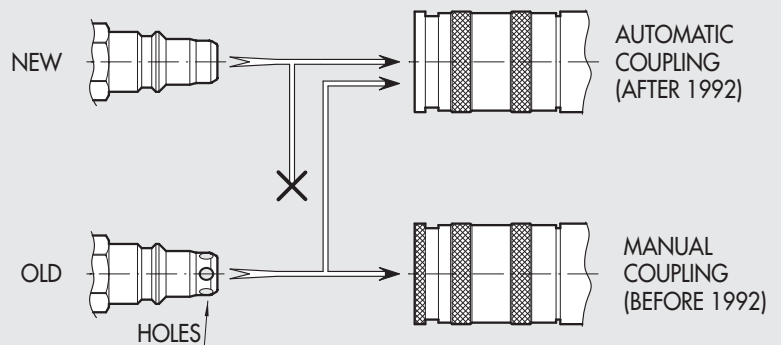

FLOW CHARTS

CURVE WITH  $\Delta P = 1 \text{ bar}$

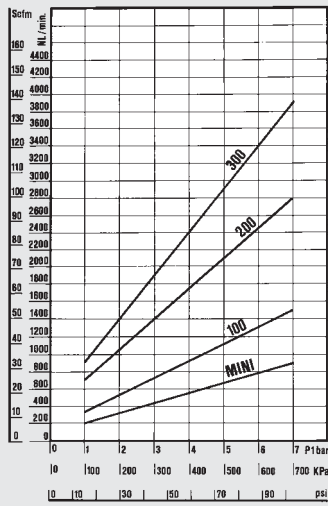

CURVE WITH FREE EXHAUST

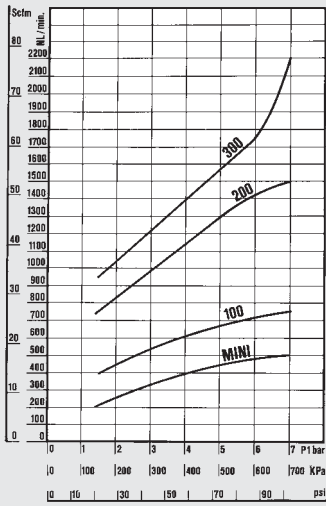

FLOW TEST DIAGRAMS

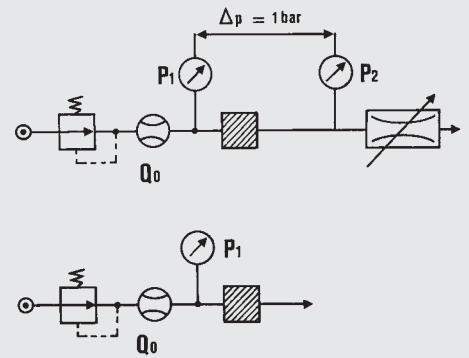

TYPICAL ASSEMBLIES

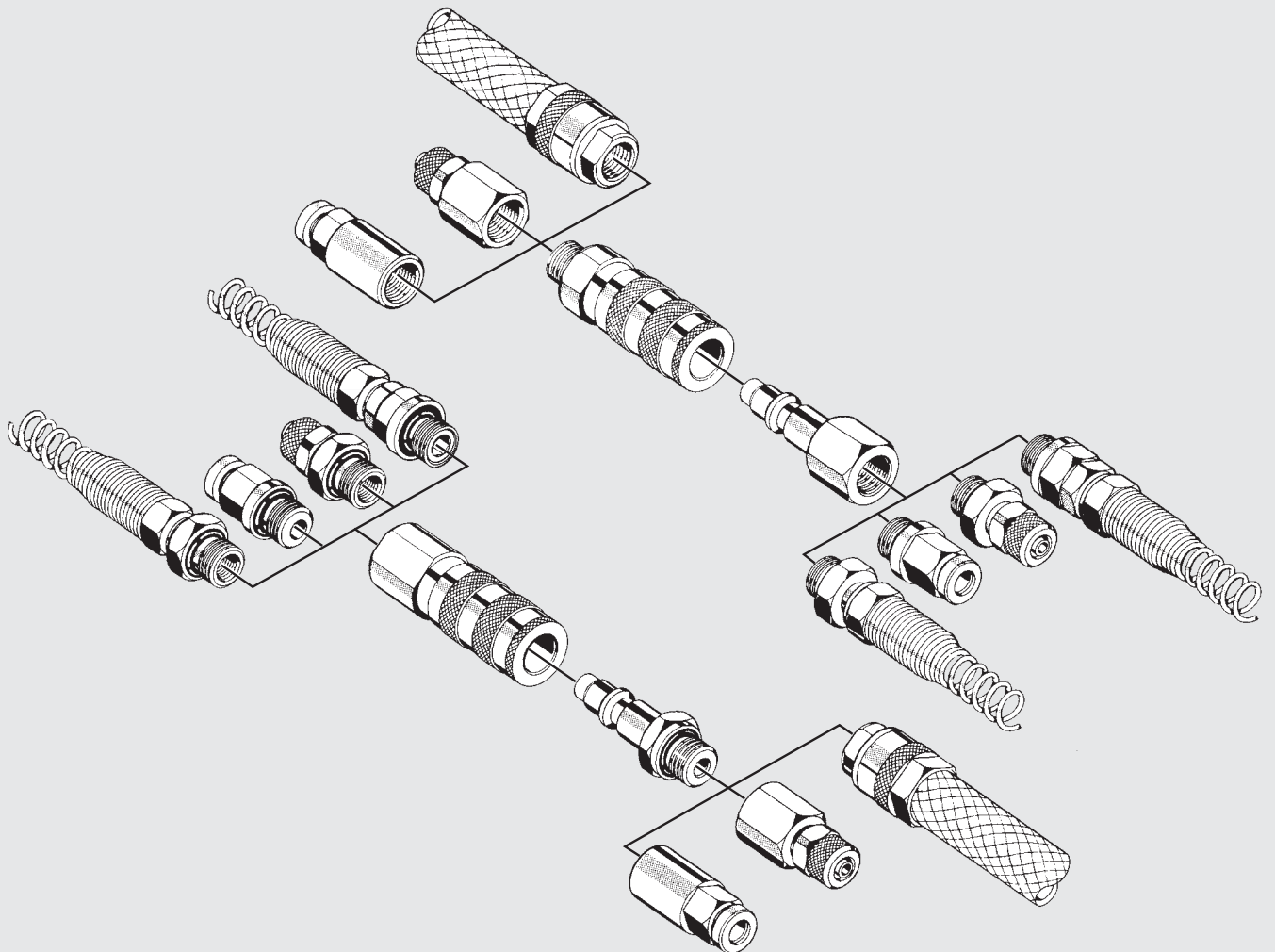

## OVERALL DIMENSIONS AND ORDERING CODES

### QUICK-FIT PORT, MALE

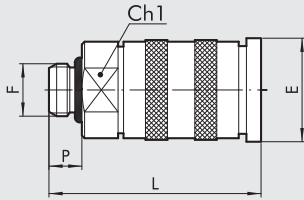

Code	Ref.	Mod.	F	Ch1	P	L	E	O-ring
0101001	01	mini	1/8	16	6.0	38.0	18.8	2031
0101002	02	mini	1/4	16	8.0	40.0	18.8	2043
0201101	101	100	1/4	21	8.0	50.0	24.4	2043
0301201	201	200	3/8	23	9.0	57.6	26.4	2056
0300202	201/A	200	1/4	23	8.0	56.6	26.4	2043
0401301	301	300	1/2	30	11.0	70.8	33.0	3068

### QUICK-FIT PORT, FEMALE

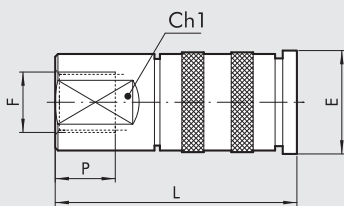

Code	Ref.	Mod.	F	Ch1	P	L	E
0101003	03	mini	1/8	16	7.0	40.5	18.8
0101004	04	mini	1/4	16	8.0	42.0	18.8
0201102	102	100	1/4	21	8.0	52.0	24.4
0301202	202	200	3/8	23	10.0	60.7	26.4
0401302	302	300	1/2	30	11.0	73.8	33.0

### QUICK-FIT PORT, NYLON PIPE

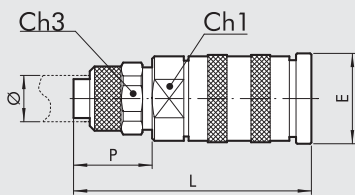

Code	Ref.	Mod.	Ø	Ch1	Ch3	P	L	E
0101005	05	mini	6/4	16	12	14.0	46.0	18.8
0101006	06	mini	8/6	16	14	14.0	46.0	18.8

### QUICK-FIT PORT, NYLON PIPE WITH SPRING

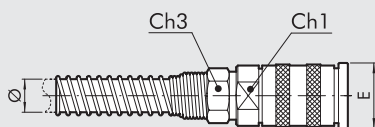

Code	Ref.	Mod.	Ø	Ch1	Ch3	E
0101007	07	mini	6/4	16	12	18.8
0101008	08	mini	8/6	16	14	18.8

### QUICK-FIT COUPLING, MALE

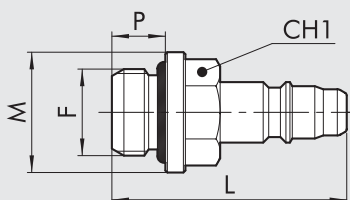

Code	Ref.	Mod.	F	Ch1	P	L	M	O-ring
0102011	11	mini	1/8	13	6.0	29.3	15	2031
0102012	12	mini	1/4	14	8.0	32.7	18	2043
0202111	111	100	1/4	14	8.0	42.2	18	2043
0302211	211	200	3/8	17	9.0	45.8	20	2056
0303205	211/A	200	1/4	16	8.0	46.2	18	2043
0402311	311	300	1/2	22	11.0	55.2	26	3068

### QUICK-FIT COUPLING, FEMALE

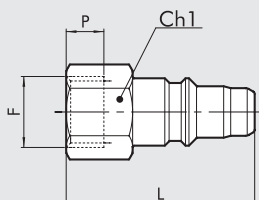

Code	Ref.	Mod.	F	Ch1	P	L
0102013	13	mini	1/8	14	7.0	29.5
0102014	14	mini	1/4	17	8.0	30.5
0202112	112	100	1/4	17	8.0	42.0
0302212	212	200	3/8	20	10.0	48.0
0402312	312	300	1/2	24	11.0	55.0

### QUICK-FIT COUPLING, NYLON PIPE

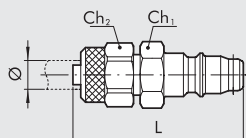

Code	Ref.	Mod.	Ø	Ch1	Ch2	L
0102015	15	mini	6/4	12	12	35.5
0102016	16	mini	8/6	14	14	35.5

### QUICK-FIT COUPLING, NYLON PIPE WITH SPRING

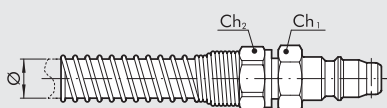

Code	Ref.	Mod.	Ø	Ch1	Ch2
0102017	17	mini	6/4	12	12
0102018	18	mini	8/6	14	14

### NYLON PIPE FITTING WITH SPRING

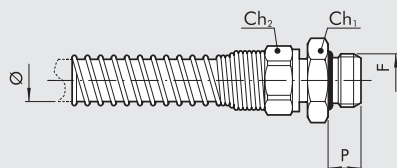

Code	Ref.	F	Ø	Ch1	Ch2	P
0010001	C1/Z	1/4	8/6	18	14	8
0010002	C1/Z	3/8	8/6	21	14	9
0010003	C1/Z	1/4	10/8	18	17	8
0010004	C1/Z	3/8	10/8	21	17	9
0010005	C1/Z	3/8	12/8	21	19	9

### HOSE FITTING

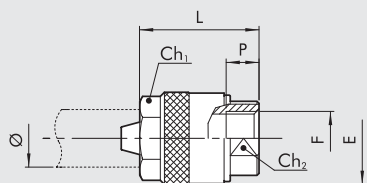

Code	Ref.	F	Ø	Ch1	Ch2	P	L	E
2601001	40	1/4	6x14	18	16	8.0	29.0	23.0
2601002	41	1/4	8x17	21	16	8.0	31.0	25.0
2601003	42	1/4	10x19	23	17	8.0	31.0	27.0
2601004	43	1/2	13x23	27	24	11.0	35.5	31.0

### SWIVEL NYLON PIPE FITTING WITH SPRING

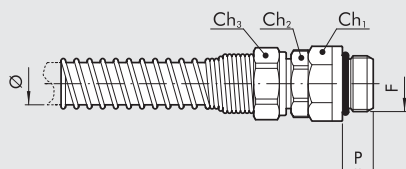

Code	Ref.	F	Ø	Ch1	Ch2	Ch3	P	O-ring
2501010	50	1/4	6/4	16	14	12	8.0	2043
2501011	51	1/4	8/6	16	14	14	8.0	2043
2501012	52	3/8	10/8	19	17	17	9.0	2056
2501013	53	3/8	12/10	19	17	19	9.0	2056

### NOTES

# QUICK-FIT COUPLING FOR MOULD CONDITIONING SERIES ICS

The mould conditioning coupling was specifically designed to speed up and facilitate the replacement of moulds in injection moulding machines. Rapid mould changeover can be easily obtained by fitting a female body at the end of the pipes conveying the thermoregulating fluid and a male coupling to the moulds. With this configuration, each mould can be connected and disconnected from the thermoregulation circuit rapidly. The presence of a female coupling with a safety valve on the pipework prevents the outflow of fluid when coupling with or releasing from the mould.



## TECHNICAL DATA

	501 V with valve	401 V with valve	503 V without valve	403 V without valve
Threaded coupling	1/8"	1/4"	1/8"	1/4"
Maximum temperature at: 1.8 MPa; 18 bar; 261 psi			+248	
			+120	
			-68	
Minimum temperature at: 1.8 MPa; 18 bar; 261 psi			-20	
			1.8	
Maximum pressure			18	
			261	
Type of gasket			FKM/FPM	

## COMPONENTS

- ① Body: nickel-plated brass
- ② Ring nut: nickel-plated brass
- ③ Valve: nickel-plated brass
- ④ Coupling: nickel-plated brass
- ⑤ Ball: stainless steel
- ⑥ Ring nut spring: AISI 302
- ⑦ Valve spring: AISI 302

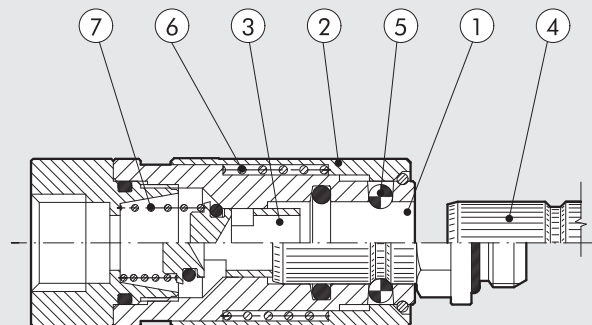

### ICS WATER FLOW CHARTS WITH SAFETY VALVE

ICS/500 1/8"

$\Delta P$  - Pressure

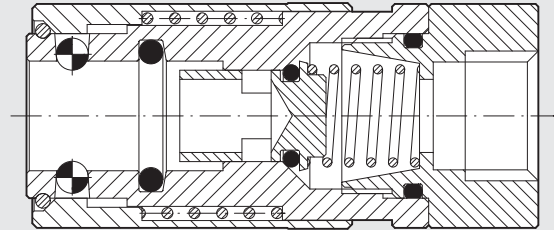
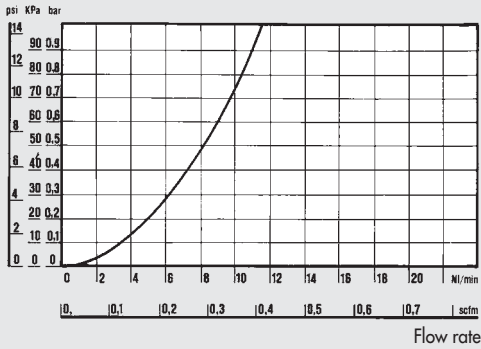

ICS/400 1/4"

$\Delta P$  - Pressure

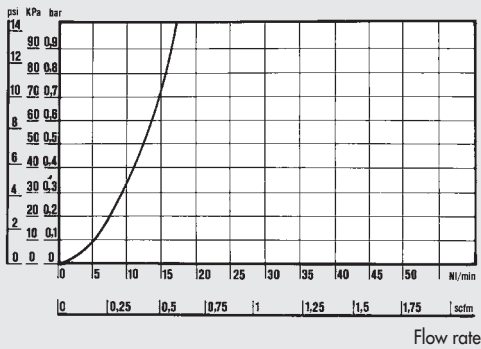

WITH SAFETY VALVE

The female body with safety valve prevents the outflow of thermoregulator fluid when coupling with or releasing from the mould.

### ICS WATER FLOW CHARTS WITHOUT SAFETY VALVE

ICS/500 1/8"

$\Delta P$  - Pressure

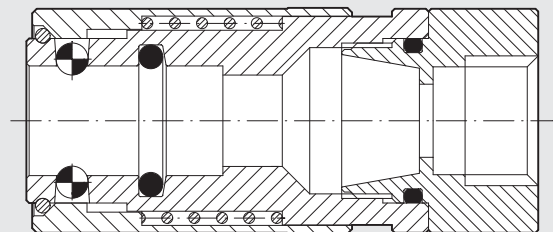
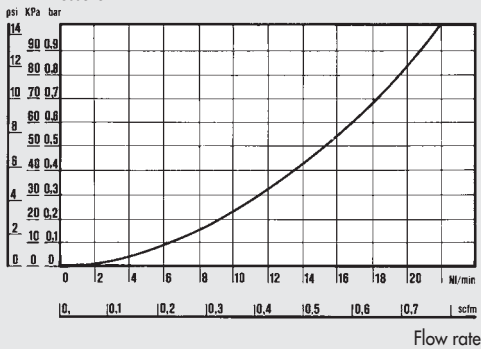

ICS/400 1/4"

$\Delta P$  - Pressure

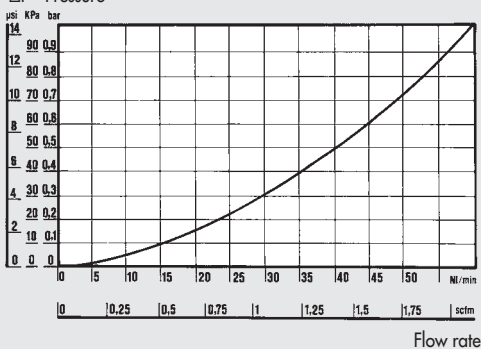

WITHOUT SAFETY VALVE

A version having a female body without a safety valve is available for when a high flow rate is required. This version allows a greater thermoregulator fluid flow rate but does not act as a fluid check valve when coupling with or releasing from the mould.

GENERAL FEATURES

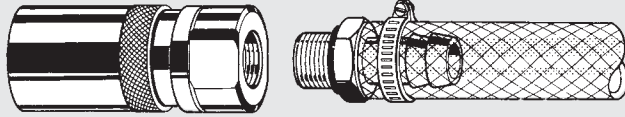

Female body plus conventional hose fitting (pipe locked with metal circlip).

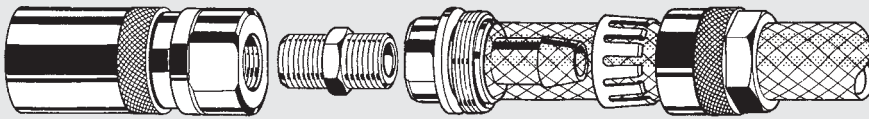

Female body plus self-locking hose fitting patented by Metal Work. When the outer ring nut is tightened, the gripper locks on the pipe.

FIG. A

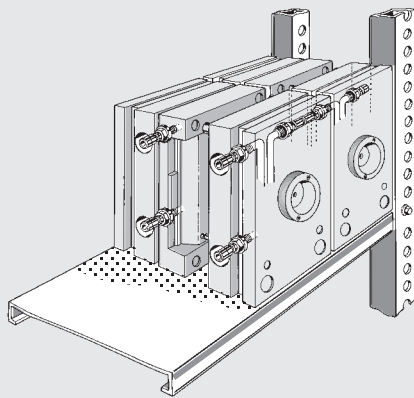

FIG. 1

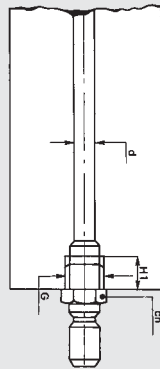
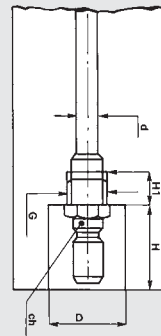

FIG. 2



The male fitting should be coupled with the mould so that it remains embedded (Fig. 2-4). This saves space and protects the coupling. The mould has no projecting parts, which would occupy more space on the storage shelving (Fig. A).

d	G	H1	Ch	D	H
4/6	1/8	7	13	20	23
7/9	1/4	9	14	26	30

FIG. B

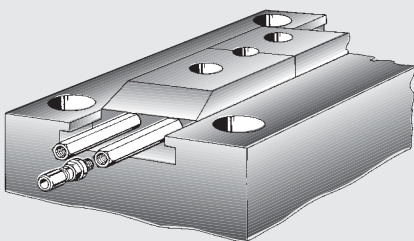

FIG. 3

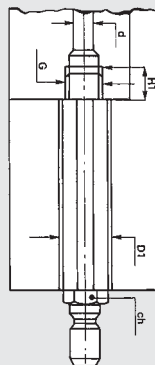
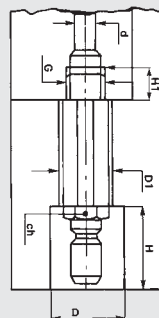

FIG. 4



The Extension (see A25 fittings) is available as an accessory. It is extremely useful when parts inside the moulds need to be thermoregulated or when the presence of trucks makes it impossible to connect the moulds to the rubber pipe. (Fig. B).

d	G	H1	Ch	D	H	D1
4/6	1/8	7	13	20	23	17
7/9	1/4	9	14	26	30	21

## OVERALL DIMENSIONS AND ORDERING CODES

### FEMALE PORT

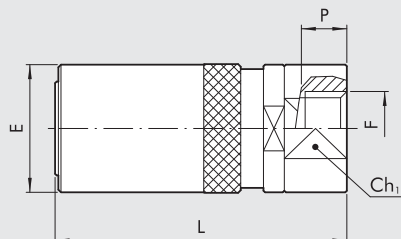

Code	Ref.	F	Safety valve	Ch1	P	L	E
0601040	501V	1/8	yes	16	7.0	45.0	19.0
0501040	401V	1/4	yes	21	8.0	56.0	25.0
0600040	503V	1/8	no	16	7.0	45.0	19.0
0500040	403V	1/4	no	21	8.0	56.0	25.0

### MALE COUPLING

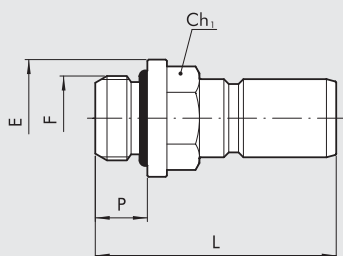

Code	Ref.	F	Ch1	P	L	E	O-ring FKM/FPM
0602001	511	1/8	13	6.0	28.5	15.0	2031
0502001	411	1/4	14	8.0	37.0	18.0	2043

### FEMALE COUPLING

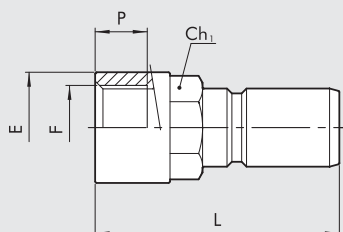

Code	Ref.	F	Ch1	P	L	E
0602002	512	1/8	12	7.0	28.0	14
0502002	412	1/4	14	8.0	37.5	17

### NOTES