

Belt Tensioners SPANN-BOX® Size 1

Material: Housing made of steel, powder-coated black. Tensioning pulley made of ultra-high-molecular polyethylene based on PE-UHMW, electrostatically dissipative.

These small, ready-to-install tensioners enable noise reduction and wear reduction at belts.

- With three springs. On choice: Two tensioning force versions. At both versions, three different forces can get activated.
- With colored wear-off indicator: Green: o.k. Yellow: still o.k. Red: Tensioning force too low.
- Usable travel up to the end of the yellow range: About 32mm. Total travel about 40mm.
- Max. permissible belt speed Typ SR-0 = 8 m/s and Typ SR-L / Typ SR-S = 6m/s.

Temperature range: -20°C to +60°C.

Ordering Details: e.g.: Product No. 14041304, Spann-Box Size 1, SR-0, Low Tensioning Force

SPANN-BOX® Size 1, SR-0, Low Tensioning Force

Product No.	B mm	E* mm	b** mm	Tension force N	Weight kg
140 413 04	53	40	45	32 - 174	0,84

SPANN-BOX® Size 1, SR-0, High Tensioning Force

Product No.	B mm	E* mm	b** mm	Tension force N	Weight kg
140 414 04	53	40	45	60 - 396	0,84

SPANN-BOX® Size 1, SR-L, Low Tensioning Force

Product No.	B mm	C mm	D mm	E* mm	b** mm	Tension force N	Weight kg
140 413 11	20	30	48	40	15	32 - 174	0,89
140 413 12	30	35	53	40	25	32 - 174	0,91
140 413 13	40	40	60	40	35	32 - 174	0,94

SPANN-BOX® Size 1, SR-L, High Tensioning Force

Product No.	B mm	C mm	D mm	E* mm	b** mm	Tension force N	Weight kg
140 414 11	20	30	48	40	15	60 - 396	0,89
140 414 12	30	35	53	40	25	60 - 396	0,91
140 414 13	40	40	60	40	35	60 - 396	0,94

SPANN-BOX® Size 1, SR-S, Low Tensioning Force

Product No.	B mm	C mm	D mm	E* mm	b** mm	Tension force N	Weight kg
140 413 21	20	46	64	40	15	32 - 174	0,89
140 413 22	30	51	69	40	25	32 - 174	0,91
140 413 23	40	56	76	40	35	32 - 174	0,93

SPANN-BOX® Size 1, SR-S, High Tensioning Force

Product No.	B mm	C mm	D mm	E* mm	b** mm	Tension force N	Weight kg
140 414 21	20	46	64	40	15	60 - 396	0,89
140 414 22	30	51	69	40	25	60 - 396	0,91
140 414 23	40	56	76	40	35	60 - 396	0,93

* Tensioning way. ** Max. recommended belt width.

Adjustable Tensioning Forces:

On choice, there are two versions, with low tensioning force or with high tensioning force. All versions have three springs, which can get activated independent from each other to reach three different tensioning forces.

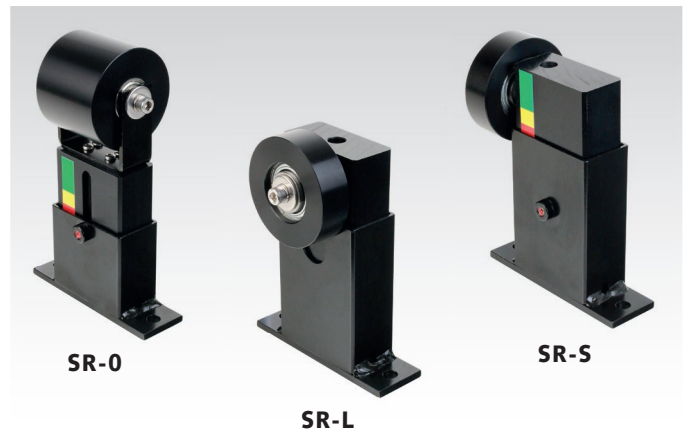

SR-0

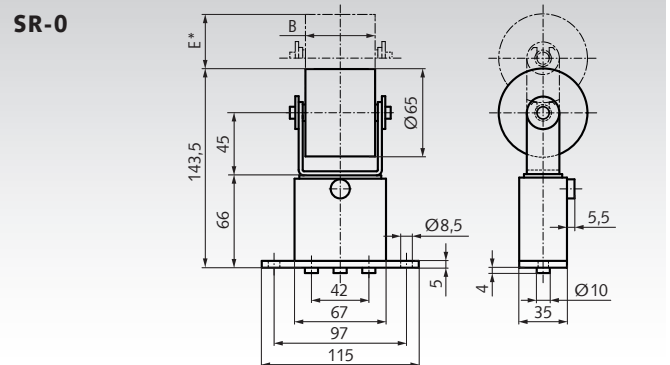

SR-L

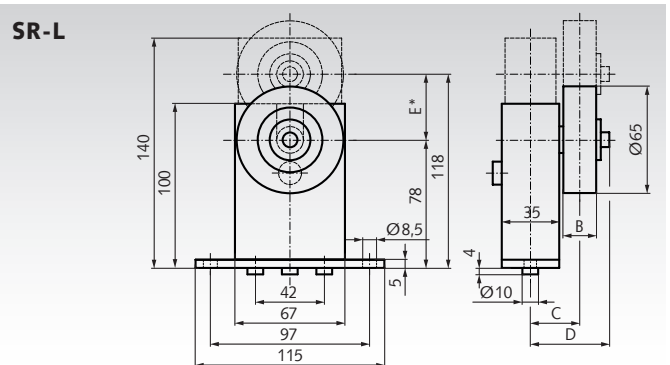

SR-S

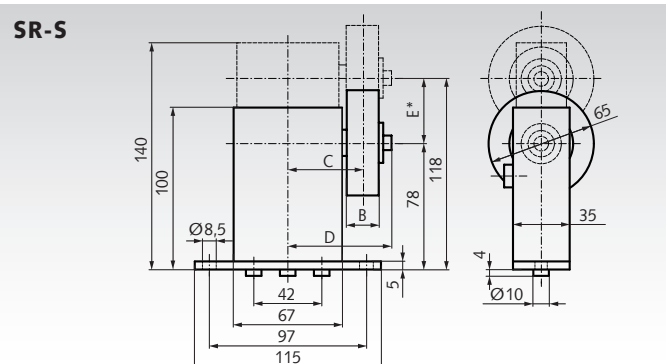

Version with low tensioning force:

- 1 spring activated: 58 - 32 N.
- 2 springs activated: 116 - 64 N.
- 3 springs activated: 174 - 96 N.

Version with high tensioning force:

- 1 spring activated: 132 - 60 N.
- 2 springs activated: 264 - 120 N.
- 3 springs activated: 396 - 180 N.