

BASE

Glass-fibre reinforced polyamide based (PA) technopolymer, black colour, matte finish.

ARTICULATED STEM

Threaded AISI 304 stainless steel with regulation hexagon.

STANDARD EXECUTIONS

- **LV.F-SST**: without no-slip disk.
- **LV.F-AS-SST**: with NBR rubber no-slip disk, hardness 70 Shore A, supplied assembled to the base.

GROUND MOUNTING

By means of two holes at 180°, supplied covered by a diaphragm (which can be easily removed by a metal tool), to avoid all unhealthy deposits of dirt and dust when the ground mounting is not required (see Fig. 1).

FEATURES

The special knurling under the lower lip of the base provides excellent stability and grip when using the levelling element without no-slip disk even on surfaces that are not perfectly flat.

The particular assembling system of the no-slip disk to the base assures a perfect anchoring, preventing separation even in case of impact during transport or of adhesion (sticking) to the floor (see No-slip disks on page 1137).

ORDER INFORMATION

The levelling elements are supplied unassembled to make carriage and storage easier. The components (base and stem) are supplied in separate packing: less volume taken and better protection from scratches and dirt.

To order bases and stems separately, see:

- table of possible combinations Bases/Stems (see page 1144)
- the codes of the Bases (see page 1139)
- the codes of the Stems (see page 1142).

ACCESSORIES ON REQUEST

AISI 304 stainless steel nut (see Nuts NT. on page 1137).



ELESA Original design

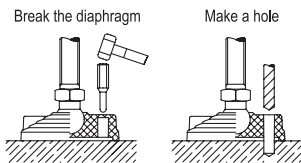
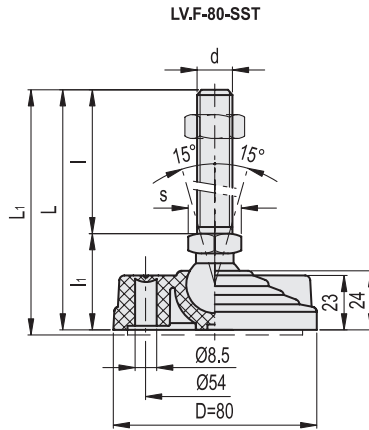

Fig.1

- 1 
- 2 
- 3 
- 4 
- 5 
- 6 
- 7 
- 8 
- 9 
- 10 
- 11 
- 12** 
- 13 
- 14 
- 15 
- 16 
- 17 
- 18 

- 1
- 2
- 3
- 4
- 5
- 6
- 7
- 8
- 9
- 10
- 11
- 12
- 13
- 14
- 15
- 16
- 17
- 18



LV.F-SST

LV.F-AS-SST

Code	Description	Code	Description	D	d	L	L1#	l	li	s	Articulation ∅	Max. limit stati load* [N]	⚖️	⚖️#
331121	LV.F-80-14-SST-M8x43	334121	LV.F-80-14-AS-SST-M8x43	80	M8	76	79	43	33	14	14	16000	86	112
331125	LV.F-80-14-SST-M8x68	334125	LV.F-80-14-AS-SST-M8x68	80	M8	101	104	68	33	14	14	16000	98	124
331221	LV.F-80-14-SST-M10x43	334221	LV.F-80-14-AS-SST-M10x43	80	M10	76	79	43	33	14	14	16000	95	121
331225	LV.F-80-14-SST-M10x68	334225	LV.F-80-14-AS-SST-M10x68	80	M10	101	104	68	33	14	14	16000	108	134
331231	LV.F-80-14-SST-M10x98	334231	LV.F-80-14-AS-SST-M10x98	80	M10	131	134	98	33	14	14	16000	122	148
331321	LV.F-80-14-SST-M12x43	334321	LV.F-80-14-AS-SST-M12x43	80	M12	76	79	43	33	14	14	16000	105	131
331325	LV.F-80-14-SST-M12x68	334325	LV.F-80-14-AS-SST-M12x68	80	M12	101	104	68	33	14	14	16000	123	149
331331	LV.F-80-14-SST-M12x98	334331	LV.F-80-14-AS-SST-M12x98	80	M12	131	134	98	33	14	14	16000	145	171
331421	LV.F-80-14-SST-M14x68	334421	LV.F-80-14-AS-SST-M14x68	80	M14	101	104	68	33	14	14	16000	146	172
331431	LV.F-80-14-SST-M14x98	334431	LV.F-80-14-AS-SST-M14x98	80	M14	131	134	98	33	14	14	16000	167	193
331441	LV.F-80-14-SST-M14x148	334441	LV.F-80-14-AS-SST-M14x148	80	M14	181	184	148	33	14	14	16000	250	276
331521	LV.F-80-14-SST-M16x68	334521	LV.F-80-14-AS-SST-M16x68	80	M16	101	104	68	33	16	14	16000	168	194
331525	LV.F-80-14-SST-M16x108	334525	LV.F-80-14-AS-SST-M16x108	80	M16	141	144	108	33	16	14	16000	222	248
331541	LV.F-80-14-SST-M16x148	334541	LV.F-80-14-AS-SST-M16x148	80	M16	181	184	148	33	16	14	16000	275	301
331561	LV.F-80-14-SST-M16x168	334561	LV.F-80-14-AS-SST-M16x168	80	M16	201	204	168	33	16	14	16000	302	328
331621	LV.F-80-24-SST-M16x58	334621	LV.F-80-24-AS-SST-M16x58	80	M16	101	104	58	43	24	24	18000	230	256
331625	LV.F-80-24-SST-M16x98	334625	LV.F-80-24-AS-SST-M16x98	80	M16	141	144	98	43	24	24	18000	282	308
331641	LV.F-80-24-SST-M16x138	334641	LV.F-80-24-AS-SST-M16x138	80	M16	181	184	138	43	24	24	18000	333	359
331661	LV.F-80-24-SST-M16x158	334661	LV.F-80-24-AS-SST-M16x158	80	M16	201	204	158	43	24	24	18000	361	387
331725	LV.F-80-24-SST-M20x98	334725	LV.F-80-24-AS-SST-M20x98	80	M20	141	144	98	43	24	24	18000	354	380
331741	LV.F-80-24-SST-M20x138	334741	LV.F-80-24-AS-SST-M20x138	80	M20	181	184	138	43	24	24	18000	434	460
331761	LV.F-80-24-SST-M20x158	334761	LV.F-80-24-AS-SST-M20x158	80	M20	201	204	158	43	24	24	18000	474	500
331781	LV.F-80-24-SST-M20x198	334781	LV.F-80-24-AS-SST-M20x198	80	M20	241	244	198	43	24	24	18000	559	585
331825	LV.F-80-24-SST-M24x98	334825	LV.F-80-24-AS-SST-M24x98	80	M24	141	144	98	43	24	24	18000	454	480
331861	LV.F-80-24-SST-M24x158	334861	LV.F-80-24-AS-SST-M24x158	80	M24	201	204	158	43	24	24	18000	629	655
331881	LV.F-80-24-SST-M24x198	334881	LV.F-80-24-AS-SST-M24x198	80	M24	241	244	198	43	24	24	18000	750	776

* The max static load is the value above which the load applied to the element may cause some plastic material breakage, in particular conditions of use. Obviously, a factor that takes into consideration the importance and the safety level of the specific application must be applied to this value.
Data with no-slip disk mounted.

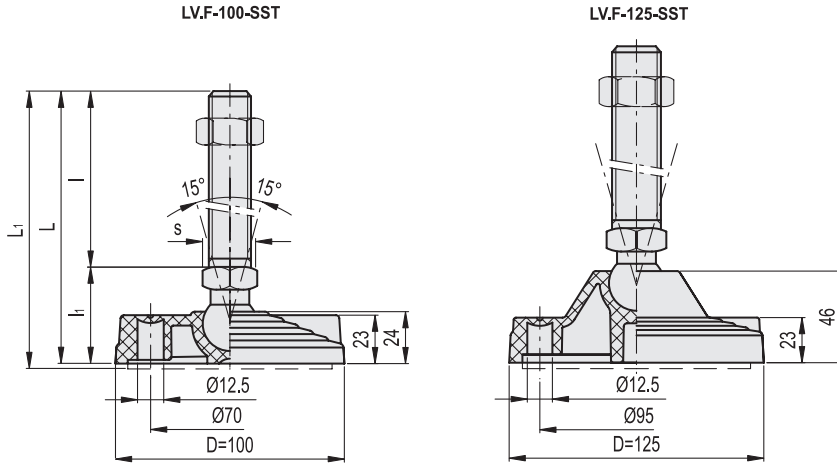

LV.F-SST

LV.F-AS-SST



Code	Description	Code	Description	D	d	L	L1#	l	li	s	Articulation ∅	Max. limit stati load* [N]	△ ₁	△ ₂ #
332451	LV.F-100-14-SST-M8x43	335451	LV.F-100-14-AS-SST-M8x43	100	M8	76	79	43	33	14	14	18000	93	148
332453	LV.F-100-14-SST-M8x68	335453	LV.F-100-14-AS-SST-M8x68	100	M8	101	104	68	33	14	14	18000	105	160
332461	LV.F-100-14-SST-M10x43	335461	LV.F-100-14-AS-SST-M10x43	100	M10	76	79	43	33	14	14	18000	102	157
332463	LV.F-100-14-SST-M10x68	335463	LV.F-100-14-AS-SST-M10x68	100	M10	101	104	68	33	14	14	18000	114	169
332465	LV.F-100-14-SST-M10x98	335465	LV.F-100-14-AS-SST-M10x98	100	M10	131	134	98	33	14	14	18000	128	183
332471	LV.F-100-14-SST-M12x43	335471	LV.F-100-14-AS-SST-M12x43	100	M12	76	79	43	33	14	14	18000	112	167
332473	LV.F-100-14-SST-M12x68	335473	LV.F-100-14-AS-SST-M12x68	100	M12	101	104	68	33	14	14	18000	129	184
332475	LV.F-100-14-SST-M12x98	335475	LV.F-100-14-AS-SST-M12x98	100	M12	131	134	98	33	14	14	18000	150	205
332477	LV.F-100-14-SST-M14x68	335477	LV.F-100-14-AS-SST-M14x68	100	M14	101	104	68	33	14	14	18000	151	206
332479	LV.F-100-14-SST-M14x98	335479	LV.F-100-14-AS-SST-M14x98	100	M14	131	134	98	33	14	14	18000	172	227
332480	LV.F-100-14-SST-M14x148	335480	LV.F-100-14-AS-SST-M14x148	100	M14	181	184	148	33	14	14	18000	255	310
332481	LV.F-100-14-SST-M16x68	335481	LV.F-100-14-AS-SST-M16x68	100	M16	101	104	68	33	16	14	18000	173	228
332483	LV.F-100-14-SST-M16x108	335483	LV.F-100-14-AS-SST-M16x108	100	M16	141	144	108	33	16	14	18000	225	280
332485	LV.F-100-14-SST-M16x148	335485	LV.F-100-14-AS-SST-M16x148	100	M16	181	184	148	33	16	14	18000	277	332
332487	LV.F-100-14-SST-M16x168	335487	LV.F-100-14-AS-SST-M16x168	100	M16	201	204	168	33	16	14	18000	303	358
332521	LV.F-100-24-SST-M16x58	335521	LV.F-100-24-AS-SST-M16x58	100	M16	101	104	58	43	24	24	25000	260	314
332525	LV.F-100-24-SST-M16x98	335525	LV.F-100-24-AS-SST-M16x98	100	M16	141	144	98	43	24	24	25000	312	366
332541	LV.F-100-24-SST-M16x138	335541	LV.F-100-24-AS-SST-M16x138	100	M16	181	184	138	43	24	24	25000	363	417
332561	LV.F-100-24-SST-M16x158	335561	LV.F-100-24-AS-SST-M16x158	100	M16	201	204	158	43	24	24	25000	391	445
332625	LV.F-100-24-SST-M20x98	335625	LV.F-100-24-AS-SST-M20x98	100	M20	141	144	98	43	24	24	25000	384	438
332641	LV.F-100-24-SST-M20x138	335641	LV.F-100-24-AS-SST-M20x138	100	M20	181	184	138	43	24	24	25000	464	518
332661	LV.F-100-24-SST-M20x158	335661	LV.F-100-24-AS-SST-M20x158	100	M20	201	204	158	43	24	24	25000	504	558
332681	LV.F-100-24-SST-M20x198	335681	LV.F-100-24-AS-SST-M20x198	100	M20	241	244	198	43	24	24	25000	589	643
332725	LV.F-100-24-SST-M24x98	335725	LV.F-100-24-AS-SST-M24x98	100	M24	141	144	98	43	24	24	25000	484	538
332761	LV.F-100-24-SST-M24x158	335761	LV.F-100-24-AS-SST-M24x158	100	M24	201	204	158	43	24	24	25000	659	713
332781	LV.F-100-24-SST-M24x198	335781	LV.F-100-24-AS-SST-M24x198	100	M24	241	244	198	43	24	24	25000	780	834
333521	LV.F-125-24-SST-M16x58	336221	LV.F-125-24-AS-SST-M16x58	125	M16	125	128	58	67	24	24	28000	399	524
333525	LV.F-125-24-SST-M16x98	336225	LV.F-125-24-AS-SST-M16x98	125	M16	165	168	98	67	24	24	28000	451	576
333541	LV.F-125-24-SST-M16x138	336241	LV.F-125-24-AS-SST-M16x138	125	M16	205	208	138	67	24	24	28000	502	627
333561	LV.F-125-24-SST-M16x158	336261	LV.F-125-24-AS-SST-M16x158	125	M16	225	228	158	67	24	24	28000	530	655
333625	LV.F-125-24-SST-M20x98	336325	LV.F-125-24-AS-SST-M20x98	125	M20	165	168	98	67	24	24	28000	523	648
333641	LV.F-125-24-SST-M20x138	336341	LV.F-125-24-AS-SST-M20x138	125	M20	205	208	138	67	24	24	28000	603	728
333661	LV.F-125-24-SST-M20x158	336361	LV.F-125-24-AS-SST-M20x158	125	M20	225	228	158	67	24	24	28000	643	768
333681	LV.F-125-24-SST-M20x198	336381	LV.F-125-24-AS-SST-M20x198	125	M20	265	268	198	67	24	24	28000	728	853
333725	LV.F-125-24-SST-M24x98	336425	LV.F-125-24-AS-SST-M24x98	125	M24	165	168	98	67	24	24	28000	623	748
333761	LV.F-125-24-SST-M24x158	336461	LV.F-125-24-AS-SST-M24x158	125	M24	225	228	158	67	24	24	28000	798	923
333781	LV.F-125-24-SST-M24x198	336481	LV.F-125-24-AS-SST-M24x198	125	M24	265	268	198	67	24	24	28000	919	1044

* The max static load is the value above which the load applied to the element may cause some plastic material breakage, in particular conditions of use. Obviously, a factor that takes into consideration the importance and the safety level of the specific application must be applied to this value.

Data with no-slip disk mounted.



Levelling elements and supports