

WAGO Kontakttechnik GmbH & Co. KG · Postfach 28 80 · 32385 Minden

WAGO Customer

WAGO Kontakttechnik GmbH & Co. KG
Postfach 28 80 · 32385 Minden
Hansastraße 27 · 32423 Minden
Tel. +49 571 887-0
Fax +49 571 887-844 169
info@wago.com
www.wago.com
Ust-IdNr. DE 814428979

Deutsche Bank, Minden
IBAN DE08 4907 0028 0296 1019 00
BIC DEUTDE33490

Sparkasse Minden-Lübbecke
IBAN DE67 4905 0101 0080 0001 85
BIC WELADED1MIN

Ihr Ansprechpartner

Durchwahl

Datum

10.28.19

Product Change Notification

PCN 2019-10-2061-1

Dear Customer,

With this letter we inform about the following product changes of our

SMD and THR PCB terminal blocks 2061 series

1. Change Reason
2. Dimensional changes
3. Change of item numbers
4. Technical data and certifications
5. Changeover schedule

1. Change Reason

In order to optimize the operation of 2061 series, the shape of push buttons and the operating tools will be changed. With the optimized geometry the tool is guided more accurately to the intended spot of operation thus ensuring an easier handling.

2. Dimensional changes

Current Version

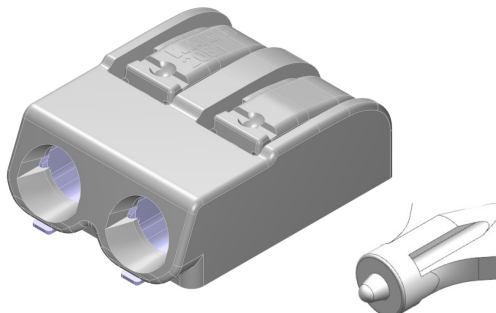

New Version

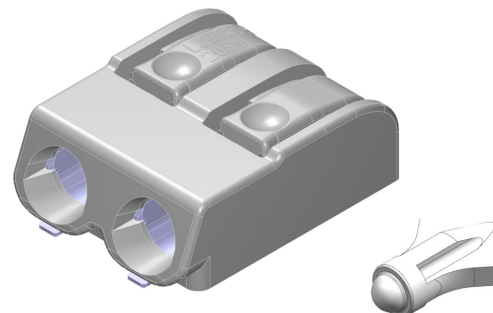

3. Change of item numbers

Terminal blocks:

Item numbers of the PCB terminal blocks 2061 (e.g. 2061-601/998-404) remain unchanged. New versions can be identified by the revised 8 digit ident-number (additionally shown on delivery note, invoice and packaging label), starting with 604, as follows:

WAGO Item Numbers	WAGO ID Current Version	WAGO ID New Version
2061-601/998-404	60257165 & 60262280	60411458
2061-602/998-404	60257166 & 60261901	60411459
2061-603/998-404	60257167 & 60261899	60411460
2061-621/998-404	60301998 & 60305318	60411461
2061-622/998-404	60257168 & 60261900	60411462
2061-623/998-404	60301997 & 60305317	60411463
2061-1601/998-404	60326336 & 60382283	60411464
2061-1602/998-404	60326337 & 60339817	60411465
2061-1603/998-404	60326338 & 60382284	60411466
2061-1621/998-404	60326342	60411501
2061-1622/998-404	60326345	60411502
2061-1623/998-404	60326351	60411503
2061-1641/998-404	60326352	60411504
2061-1642/998-404	60326359	60411505
2061-1643/998-404	60326360	60411506
2061-1661/998-404	60256417	60411470
2061-1662/998-404	60326362	60411471
2061-1663/998-404	60256413	60411472

Operating tools:

Current Version

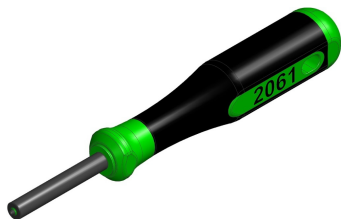

206-861

New Version

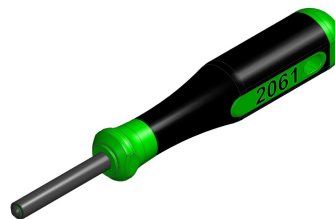

206-866

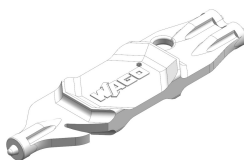

2061-189

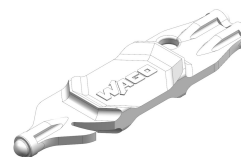

2061-190



4. Technical data and certifications

The overall dimensions and technical data of the new versions are identical to the current versions. They can be used in combination with the existing connecting links. UL and EN/IEC certification data are identical and certifications remain valid.

5. Changeover schedule

The changeover is scheduled for the next 6 months and will be executed without further notice.

Although the new versions can be operated with the old operating tools 206-861 and 2061-189 we recommend to order the new tools 206-866 or 2061-190 in advance and use them for optimized handling of the new versions after the changeover!

With best regards,

WAGO Corporation
800.346.7245