

Signal converter 7379.5021 and 7379.5021/CO DMS input → IO – Link (V1.1)

Product Features:

- 1x strain gauge input for connecting a strain gauge full bridge sensor
- Simple device parameterization via IO-Link possible using various engineering tools
- Numerous connection options via expansion option (7379.5021/CO) (three additional control inputs and two additional control outputs)
- Adjustable limit value monitoring possible
- Generation of pending events (e.g. calculated bridge resistance above or below the set target resistance, bridge current > 50 mA, undervoltage, ...) possible
- Compact rail housing to EN60715

Available Options:

7379.5021: Basic device with strain gauge input for a strain gauge full bridge sensor

7379.5021/CO: Basic device with strain gauge input for a strain gauge full bridge sensor and additional 3x HTL PNP control inputs and 2x PNP control outputs

Inhaltsverzeichnis

1.	Safety Instructions and Responsibility	4
1.1.	General Safety Instructions	4
1.2.	Use according to the intended purpose	4
1.3.	Installation	5
1.4.	EMC Guidelines	6
1.5.	Cleaning, Maintenance and Service Notes.....	6
2.	Introduction	7
2.1.	Function diagram	8
3.	Electrical Connections	9
3.1.	DC Power Supply	9
3.2.	DMS Input.....	10
3.3.	Control Inputs (only with option „CO“)... ..	11
3.4.	Control Outputs (only with option „CO“)... ..	12
3.5.	IO-Link Interface.....	13
3.5.1.	Usable IO Link masters	13
3.5.2.	Communication data.....	13
3.5.3.	Features	13
3.5.4.	Front LED	13
3.5.5.	Connection of the IO Link interface.....	14
3.5.6.	Parameter data	14
3.5.7.	System Kommandos	17
3.5.8.	IO-Link Process data	18
3.5.9.	Error types.....	19
3.5.10.	Events.....	20
4.	Parameter / Overview - Menu Structure	21
4.1.	Sensor Menu.....	22
4.2.	Digital Input Menu	24
4.3.	Digital Output Menu	25
4.4.	General Menu	29
4.5.	Adjustment Menu	30
5.	Commissioning	32
5.1.	Basic setting of the strain gauge sensor.....	32
5.2.	Easiest setting	33
5.3.	Conversion to sensor units	34
5.4.	Digital Input	35
5.5.	Digital Output.....	35
5.6.	Other optional settings.....	35
5.6.1.	Examination of the analog read in values.....	35
5.7.	Calibration of the MEA readback.....	35
5.8.	Calibration of analog input BRI / DMS.....	35
5.8.1.	Input stage calibration.....	36
5.8.2.	Calibration of the input stage and the DMS sensor.....	37
5.8.3.	Monitor codes for calibration.....	38

6.	Attachment	39
6.1.	Parameter / serial codes.....	39
6.2.	Dimensions	41
6.3.	Technical Specifications.....	42

1. Safety Instructions and Responsibility

1.1. General Safety Instructions

This operation manual is a significant component of the unit and includes important rules and hints about the installation, function and usage. Non-observance can result in damage and/or impairment of the functions to the unit or the machine or even in injury to persons using the equipment!

Please read the following instructions carefully before operating the device and observe all safety and warning instructions! Keep the manual for later use.

A pertinent qualification of the respective staff is a fundamental requirement in order to use this manual. The unit must be installed, connected and put into operation by a qualified electrician.

Liability exclusion: The manufacturer is not liable for personal injury and/or damage to property and for consequential damage, due to incorrect handling, installation and operation. Further claims, due to errors in the operation manual as well as misinterpretations are excluded from liability.

In addition, the manufacturer reserves the right to modify the hardware, software or operation manual at any time and without prior notice. Therefore, there might be minor differences between the unit and the descriptions in operation manual.

The raiser respectively positioner is exclusively responsible for the safety of the system and equipment where the unit will be integrated.

During installation or maintenance all general and also all country- and application-specific safety rules and standards must be observed.

If the device is used in processes, where a failure or faulty operation could damage the system or injure persons, appropriate precautions to avoid such consequences must be taken.

1.2. Use according to the intended purpose

The unit is intended exclusively for use in industrial machines, constructions and systems. Non-conforming usage does not correspond to the provisions and lies within the sole responsibility of the user. The manufacturer is not liable for damages which have arisen through unsuitable and improper use.

Please note that device may only be installed in proper form and used in a technically perfect condition (in accordance to the Technical Specifications). The device is not suitable for operation in explosion-proof areas or areas which are excluded by the EN 61010-1 standard.

1.3. Installation

The device is only allowed to be installed and operated within the permissible temperature range. Please ensure an adequate ventilation and avoid all direct contact between the device and hot or aggressive gases and liquids.

Before installation or maintenance, the unit must be disconnected from all voltage-sources. Further it must be ensured that no danger can arise by touching the disconnected voltage-sources.

Devices which are supplied by AC-voltages must be connected exclusively by switches, respectively circuit-breakers with the low voltage network. The switch or circuit-breaker must be placed as near as possible to the device and further indicated as separator.

Incoming as well as outgoing wires and wires for extra low voltages (ELV) must be separated from dangerous electrical cables (SELV circuits) by using a double resp. increased isolation.

All selected wires and isolations must be conformed to the provided voltage- and temperature-ranges. Further all country- and application-specific standards, which are relevant for structure, form and quality of the wires, must be ensured. Indications about the permissible wire cross-sections for wiring are described in the Technical Specifications.

Before first start-up it must be ensured that all connections and wires are firmly seated and secured in the screw terminals. All (inclusively unused) terminals must be fastened by turning the relevant screws clockwise up to the stop.

Overvoltages at the connections must be limited to values in accordance to the overvoltage category II.

1.4. EMC Guidelines

All motrona devices are designed to provide high protection against electromagnetic interference. Nevertheless you must minimize the influence of electromagnetic noise to the device and all connected cables.

Therefore the following measures are mandatory for a successful installation and operation:

- Use shielded cables for all signal and control input and output lines.
- Cables for digital controls (digital I/O, relay outputs) must not exceed a length of 30 m and are allowed for in building operation only
- Use shield connection clamps to connect the cable shields properly to earth
- The wiring of the common ground lines must be star-shaped and common ground must be connected to earth at only one single point
- The device should be mounted in a metal enclosure with sufficient distance to sources of electromagnetic noise.
- Run signal and control cables apart from power lines and other cables emitting electromagnetic noise.

Please also refer to motrona manual "General Rules for Cabling, Grounding, Cabinet Assembly". You can download that manual by the link

<https://www.motrona.com/en/support/general-certificates.html>

1.5. Cleaning, Maintenance and Service Notes

To clean the front of the unit please use only a slightly damp (not wet!), soft cloth. For the rear no cleaning is necessary. For an unscheduled, individual cleaning of the rear the maintenance staff or assembler is self-responsible.

During normal operation no maintenance is necessary. In case of unexpected problems, failures or malfunctions the device must be shipped for back to the manufacturer for checking, adjustment and repair (if necessary). Unauthorized opening and repairing can have negative effects or failures to the protection-measures of the unit.

2. Introduction

The 7379.5021 or the 7379.5021/CO are devices for connecting a strain gauge full bridge sensor, the converted measurement result of which is transmitted cyclically via the process data via IO Link. The "CO" expansion option also has three HTL PNP control inputs and two PNP switching outputs. These switching outputs transmit when switching points are exceeded or fallen below, as well as movements outside of a range. A DMS error can also be signaled. With the help of "System Commands" via IO-Link or via one of the three additional HTL Control inputs, a zero setting of the strain gauge sensor can be triggered or the self-locking on the outputs can be withdrawn. The status of the control inputs and outputs as well as relevant diagnostic information are also transmitted cyclically with the process data. In addition, any pending events (e.g. calculated bridge resistance above or below the set target resistance, bridge current > 50 mA, undervoltage, ...) can be generated if this is desired by the user. The individual device parameters can be set and saved using various engineering tools or during operation via IO-Link. Thanks to the supported "data storage" mechanism, an uncomplicated and problem-free exchange of devices is possible at any time.

2.1. Function diagram

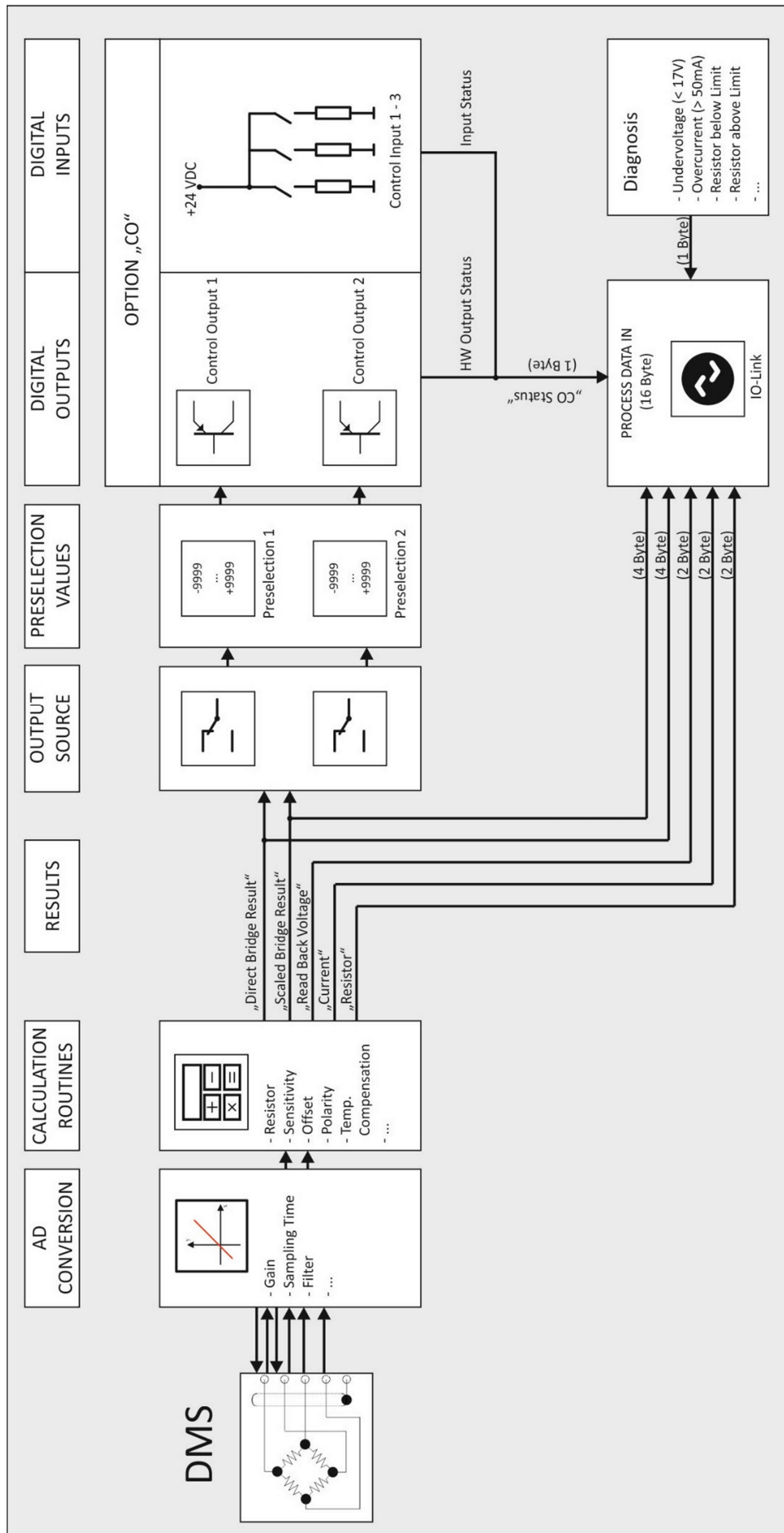

3. Electrical Connections

The terminal screws should be tightened with a slotted screwdriver (blade width 2mm).

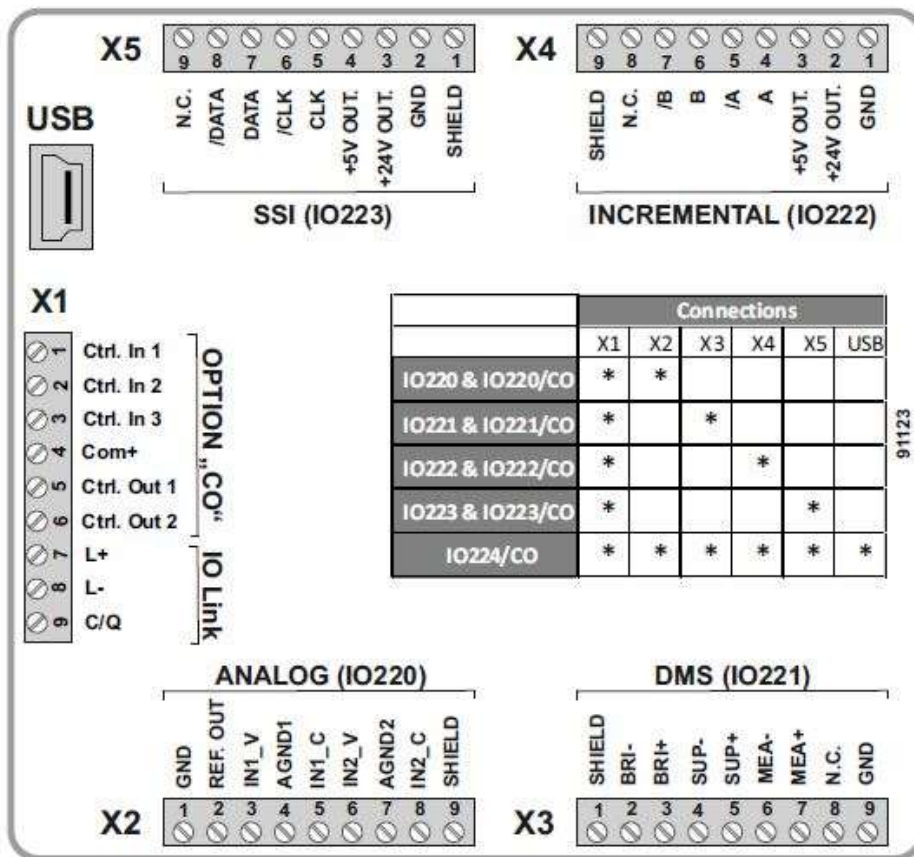

3.1. DC Power Supply

The unit accepts DC supply from 18 to 30 V at the terminals X1 pin 7 (+) and 8 (-). The power consumption depends on the level of the supply voltage with approx. 75 mA (at 24V).

All GND terminals are internally interconnected.

3.2. DMS Input

Strain gauge full bridge supply

With the terminals SUP+, SUP- resp. X3 Pin 5 (+) and Pin 4 (-) the DMS sensor can be supplied by a programmable voltage of 3V - 10VDC with max. 50mA. The supply voltage can be read back in mV via Index „40“, Subindex „19“

DMS full bridge readback

With the terminals MEA+, MEA- resp. X3 Pin 7 (+) and Pin 6 (-) the DMS sensor supply voltage can be read back. These terminals must be connected in any case, ideally directly at the full bridge, in order to avoid voltage drops at the supply line.

DMS full bridge voltage

With the terminals BRI+, BRI- resp. X3 Pin 3 (+) and Pin 2 (-) the DMS bridge voltage can be evaluated. The bridge voltage in units can be read back via „Index 40“, Subindex „21“

Connection example DMS sensor

The picture below shows an example of how to connect a strain gauge sensor. (SUP = Supply, MEA = Measurement of Supply, BRI = Bridge Voltage)

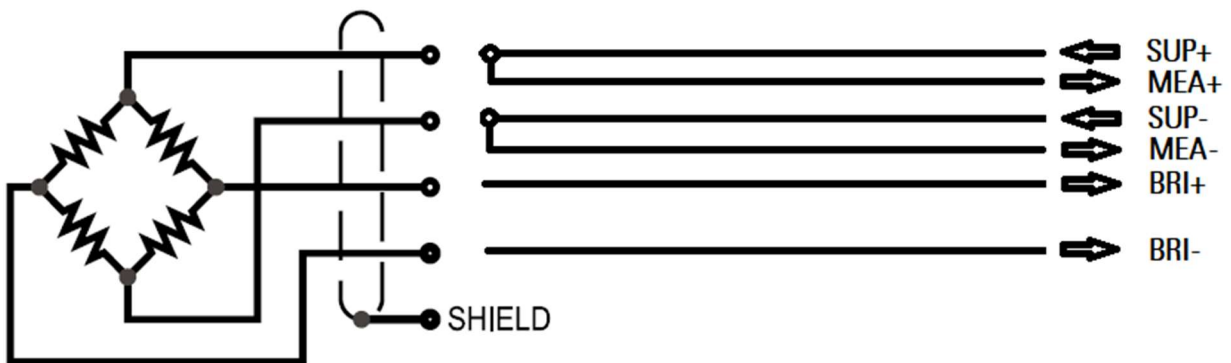

3.3. Control Inputs (only with option „CO“)

Three control inputs with HTL PNP characteristics are available on terminal X1, pins 1, 2 and 3. The current state of the control inputs is cyclically exchanged with the process data and can therefore be used for a wide variety of functions. (e.g. as a trigger signal to trigger a "system command" or to read out current actual values via the PLC). The respective input can also be configured with a fixed function ("INPUT x FUNCTION") via the "DIGITAL INPUT MENU". (e.g. "Tara" of the DMS input)

Connection of the control inputs:

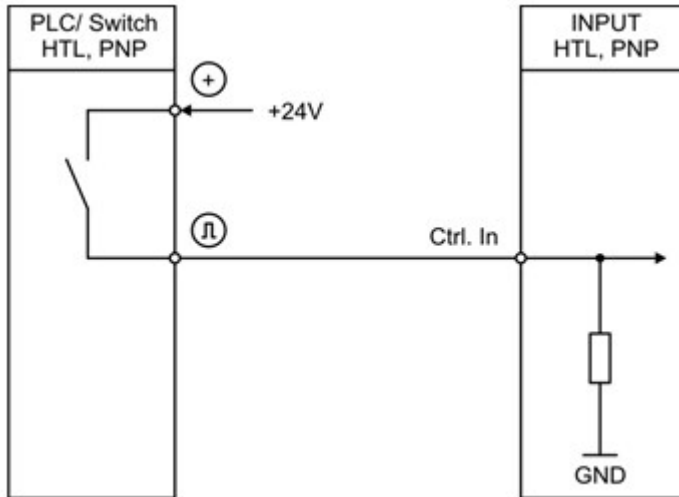

Unconnected control inputs are always "LOW".

All inputs are designed to receive impulses from an electronic impulse source.



Notice for mechanical switching contacts:

When exceptionally mechanical contacts are used, please connect an external capacitor between GND (-) and the corresponding input (+). A capacity of 10 μF will reduce the input frequency to

20 Hz and miscounting due to contact bouncing will be eliminated.

3.4. Control Outputs (only with option „CO“)

Two control outputs are available on terminal X1, pins 5 and 6. Depending on the configuration ("DIGITAL OUTPUT MENU"), they can transmit different statuses.

The outputs Ctrl. Out 1 and 2 are designed as high side drivers. The status of the outputs is transmitted cyclically with the IO-Link process data.

The switching voltage is determined by the external voltage supplied to terminal X1 pin 4 (COM+). External damping measures are recommended for switching inductive loads.

Connection of the control outputs:

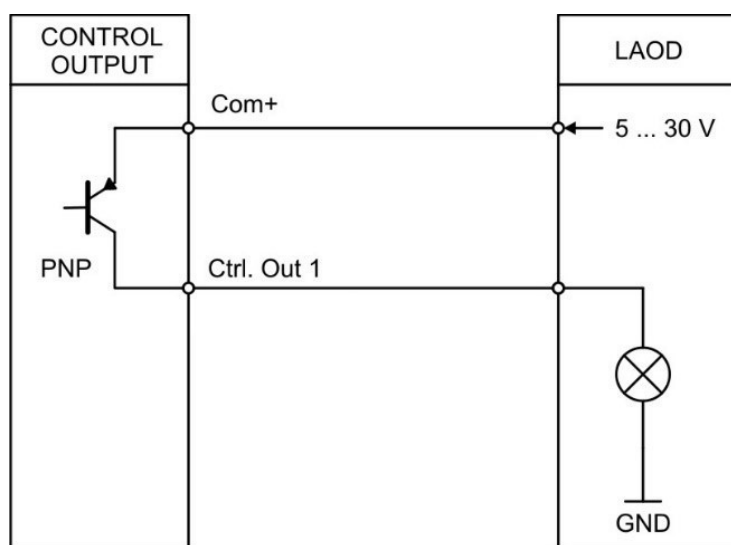

3.5. IO-Link Interface

This chapter contains important notes and information regarding IO-Link communication data. In addition to general information on the IO-Link connection, the parameter data of the device, the exchanged process data and the implemented system commands, error codes and events are discussed.

3.5.1. Usable IO Link masters

All IO-Link masters that support IO-Link Standard V1.1.

3.5.2. Communication data

Parameters	Values
Communication speed	COM 3
Transmission rate	230,4 kbit/s
IO-Link Revision	V1.1
Cycle time	min. 2 ms
Port class	Class A

3.5.3. Features

Feature	Unterstützt
Block parametrization	Yes
Data Storage	Yes
Events	Yes
SIO Mode	No

3.5.4. Front LED

In the case of devices without the "CO" option, the green LED on the front is used exclusively as a ready-to-operate display. As soon as a supply voltage has been applied to the device, it lights up continuously.

For devices with the extended "CO" option, the green LED on the front serves as a ready-to-operate display. It also signals the current IO-Link system status.

LED lights up continuously:

The device is connected to the supply voltage and there is no IO-Link communication. The device is in "START UP MODE".

LED flashes at 0.5 Hz:

Device is connected to the supply voltage and IO-Link communication is currently in "PREOPERATE MODE" (no cyclic data exchange takes place).

LED flashes at 1 Hz cycle:

The device is connected to the supply voltage and IO-Link communication is currently in "OPERATE MODE" (cyclic data exchange is taking place).

3.5.5. Connection of the IO Link interface

An interface for connecting to an IO-Link master port is available on terminal X1 pin 7 (L-), 8 (L+) and 9 (C/Q). Figure 1 shows the pin assignment of a standard M12 connector plug.

Assignment		
	Pin 1	Clamp L+
	Pin 2	Not connected
	Pin 3	Clamp L-
	Pin 4	IO-Link data line, C/Q

Fig. 1: Pin assignment M12 connection plug

Pin	Wire color
1 (L+)	brown
2 (n.c.)	white
3 (L-)	blue
4 (C/Q)	black

3.5.6. Parameter data

ISDU Index	DPP1 Index	Name of the Parameter	Access	Length in bytes	Default Value	Range
Identification Menu						
	7	VendorID	R	2	980 / 0x 03D4	-
	8					
	9	Device ID	R	3	2228481 / 0x220101	-
	10					
	11					
16		Vendor Name	R	12	motrona GmbH	-
17		Vendor Text	R	21	http://www.motrona.de	-
18		Product Name	R	16	signal amplifier	-
19		Product ID	R	8	7379.5021 oder 7379.5021/CO	-
20		Product Text	R	36	DMS amplifier with IO- Link interface	-
21		Serial Number	R	9	-	-
22		Hardware Revision	R	7	z.B.: 224I011	-
23		Firmware Revision	R	8	z.B.: 7379.502101A	-
24		Application Specific Tag	R/W	Max. 32	***	-
36		Device Status	R	1	0x00	0: Device is working properly 1: Maintenance required 2: Out of specification 3: Functional test 4: Error 5-255: Reserved
40		Prozess Data Input	R	16	-	-

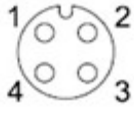
ISDU Index	DPP1 Index	Name of the Parameter	Access	Length in bytes	Default Value	Range
SENSOR MENU						
258		SENSOR SUPPLY	R/W	4	5	3..10
259		SENSOR GAIN	R/W	4	0	0..4
260		SENSOR OSR	R/W	4	0	0..12
261		SENSOR OFFSET	R/W	4	0	-10000..10000
262		SENSOR RESISTOR	R/W	4	350	0..10000
263		SENSOR SENSITIVITY	R/W	4	1000	100..20000
264		SENSOR VOLTAGE	R/W	4	1000	1..99999
265		SENSOR DIGIT	R/W	4	1000	1..99999
266		SENSOR CORRECTION	R/W	4	1000	900..1100
267		SENSOR POLARITY	R/W	4	0	0..1
DIGITAL INPUT MENU						
272		INPUT 1 CONFIG	R/W	4	2	0..3
273		INPUT 1 FUNCTION	R/W	4	0	0..6
274		INPUT 2 CONFIG	R/W	4	2	0..3
275		INPUT 2 FUNCTION	R/W	4	0	0..6
276		INPUT 3 CONFIG	R/W	4	2	0..3
277		INPUT 3 FUNCTION	R/W	4	0	0..6
DIGITAL OUTPUT MENU						
281		OUTPUT POLARITY	R/W	4	0	0..3
282		OUTPUT LOCK	R/W	4	0	0..3
283		OUTPUT SOURCE 1	R/W	4	0	0..1
284		OUTPUT FUNCTION 1	R/W	4	7	0..7
285		OUTPUT HYSTERESIS 1	R/W	4	0	0..9999
286		OUTPUT PRESELECTION 1	R/W	4	1000	-9999..9999
287		OUTPUT SOURCE 2	R/W	4	0	0..1
288		OUTPUT FUNCTION 2	R/W	4	7	0..7
289		OUTPUT HYSTERESIS 2	R/W	4	0	0..9999
290		OUTPUT PRESELECTION 2	R/W	4	1000	-9999..9999
GENERAL MENU						
294		FILTER	R/W	4	0	0..9
295		MIN MAX CHANNEL	R/W	4	0	0..2
296		DIAGNOSIS SETUP	R/W	4	0 (0x00)	0x00..0x0F
ADJUSTMENT MENU						
302		TCI BRIDGE OFFSET	R/W	4	10000	5000..15000
303		TCI BRIDGE GAIN	R/W	4	100000	90000..110000
304		TEMP. COMP. (TCI)	R/W	4	0	0..3
305		BRIDGE SUPPLY ADJUST	R/W	4	10000	8000..12000
306		TCI OFFSET INVERSION	R/W	4	0	0..1
307		TCI GAIN INVERSION	R/W	4	0	0..1
308		TEMP. SIMULATION	R/W	4	0	0..1
309		TEMP. SIM. VALUE	R/W	4	1140	870..1412
310		BRIDGE SUPPLY COMP.	R/W	4	0	0..1
311		BRIDGE SUPPLY REF.	R/W	4	5000	0..11000

ISDU Index	DPP1 Index	Name of the Parameter	Access	Length in bytes	Default Value	Range
Observation Menu (Read Out Variables)						
657		Read Back Voltage Value (Raw Value)	R	4	-	-
658		Bridge Value (Raw Value)	R	4	-	-
659		Maximum Value	R	4	-	-
660		Minimum Value	R	4	-	-
661		ADC Time	R	4	-	-
662		Read Back Offsetcorrection	R	4	-	-
663		Factor of the Gain Compensation	R	4	-	-
664		Result with Offset, Offset- and Gain- Compensation	R	4	-	-
665		Temperature	R	2	-	-

3.5.7. System Kommandos



A system command is a write-only parameter that causes an action in the device. To invoke the desired action, the corresponding value must be written to **index 2, subindex 0**. If the desired command is a static command (s), this command remains active until the corresponding value is written again to index 2, subindex 0. By resending the command, the action is terminated.

Predefined commands

Name	Index	Subindex	Value	Description of the action	Dynamic (d)/static (s)
RESTORE FACTORY SETTINGS	2	0	130	Reset all parameters and application specific tag to factory settings.	(d)
APPLICATION RESET	2	0	129	Reset all parameters to factory settings.	(d)

Application specific commands

Name	Index	Subindex	Value	Description of the action	Dynamic (d)/static (s)
TARA	2	0	160	Tara for bridge voltage (zeroing).	(d)
LOCK RELEASE 1	2	0	161	Reset latch for output 1.	(d)
LOCK RELEASE 2	2	0	162	Reset latch for output 2.	(d)
LOCK RELEASE 1+2	2	0	163	Reset latch for output 1+2.	(d)
CLEAR MIN/MAX VALUES	2	0	164	Reset of the min. / max. values.	(d)
QUIT. OVERCURRENT	2	0	165	Acknowledgment after overcurrent error message. (>50mA).	(d)
STORE EEPROM	2	0	168	Current parameter settings are saved in non-volatile memory.	(d)

3.5.8. IO-Link Process data

Process input data (Total: 16 Byte):

(View from the IO-link master)

Bit	Byte	Subindex	Beschreibung
Bit 0	Byte 15	1	Diagnosis: Overcurrent (> 50mA) detected.
Bit 1		2	Diagnosis: Calculated resistance is above the set range.
Bit 2		3	Diagnosis: Calculated resistance is below the set range.
Bit 3		4	Diagnosis: Device supply undervoltage (< 17 V)
Bit 4		5	Diagnosis: Reserved
Bit 5		6	Diagnosis: Reserved
Bit 6		7	Diagnosis: Device Test – Error (only for Test Purpose!)
Bit 7		8	Diagnosis: Device Test – Warning (only for Test Purpose!)
Bit 0	Byte 14	9	Input State: Control Input 1 (0: OFF / 1: ON)
Bit 1		10	Input State: Control Input 2 (0: OFF / 1: ON)
Bit 2		11	Input State: Control Input 3 (0: OFF / 1: ON)
Bit 3		12	HW Output State: Control Output 1 (0: OFF / 1: ON)
Bit 4		13	HW Output State: Control Output 2 (0: OFF / 1: ON)
Bit 5		14	Reserved
Bit 6		15	Reserved
Bit 7		16	Reserved
-	Byte 12...13	17	Process Value 5 Calculated Resistor (in Ohm) - (Datatype: Int16)
-	Byte 10...11	18	Process Value 4:: Actual Current (in 1/10 mA) - (Datatype: Int16)
-	Byte 8...9	19	Process Value 3:: Read Back Voltage (in mV) - (Datatype: Int16)
-	Byte 4...7	20	Process Value 2 Scaled Bridge Result - (Datatype: Int32)
-	Byte 0...3	21	Process Value 1:: Direct Bridge Result - (Datatype: Int32)



The acyclic request address of the process input data is **index 40**. The corresponding **subindex** and the corresponding data type of the desired value that is to be read can be found in the table above.

3.5.9. Error types

Error code	Name	Description
32768 / 0x 8000	Application errors in the device-no details	Access was denied by the device. No detailed information is available.
32785 / 0x 8011	Index does not exist	Access to a non-existent index.
32786 / 0x 8012	Subindex does not exist	Access to a non-existent subindex..
32800 / 0x 8020	Service not available at this time	The parameter cannot be accessed at this moment. The device does not allow this in the current state.
32803 / 0x 8023	Access denied	Write access to a read-only parameter.
32816 / 0x 8030	Parameter value out of range	Parameter value is outside the allowed range of values.
32817 / 0x 8031	Parameter value greater than specified range	The written parameter value is greater than the specified value range.
32818 / 0x 8032	Parameter value less than specified range	The written parameter value is smaller than the specified value range.
32819 / 0x 8033	Parameter length too large	Parameter length is greater than allowed.
32820 / 0x 8034	Parameter length too small	Parameter length is less than allowed.
32821 / 0x 8035	Function not available	The device does not support the command.
32822 / 0x 8036	Function not available at this time	The command is not supported by the device in its current state.
32832 / 0x 8040	Invalid parameter set	Written single parameter value collides with the other parameter settings.
32833 / 0x 8041	Inconsistent parameter set	Inconsistencies were detected at the end of the block parameter transfer. The device plausibility check failed.
32898 / 0x 8082	Application not ready	Access was denied because the device is not ready.

3.5.10. Events

Code	Typ	Device Status	Bedingung
0x1853	Error	0x04	Diagnosis: Overcurrent (> 50mA) detected.
0x1854	Error	0x04	Diagnosis: Calculated resistance is above the set range.
0x1855	Error	0x04	Diagnosis: Calculated resistance is below the set range.
0x180C	Warning	0x02	Diagnosis: Device supply undervoltage (< 17 V)
0x8D68	Error	0x00	Device Test: Error (only for Test Purpose!)
0x8D04	Warning	0x00	Device Test: Warning (only for Test Purpose!)

4. Parameter / Overview - Menu Structure

The device is parameterized via the IO-Link interface using a suitable engineering tool, which is usually provided by the IO-Link master manufacturers. This section shows the overview of the individual menus and their parameters. The menu name is written in bold, the associated parameters are arranged directly under the menu name.

Menu / Parameter
SENSOR MENU
SENSOR SUPPLY
SENSOR GAIN
SENSOR OSR
SENSOR OFFSET
SENSOR RESISTOR
SENSOR SENSITIVITY
SENSOR VOLTAGE
SENSOR DIGIT
SENSOR CORRECTION
SENSOR POLARITY
DIGITAL INPUT MENU
INPUT 1 CONFIG
INPUT 1 FUNCTION
INPUT 2 CONFIG
INPUT 2 FUNCTION
INPUT 3 CONFIG
INPUT 3 FUNCTION
DIGITAL OUTPUT MENU
OUTPUT POLARITY
OUTPUT LOCK
OUTPUT SOURCE 1
OUTPUT FUNCTION 1
OUTPUT HYSTERESIS 1
OUTPUT PRESELECTION 1
OUTPUT SOURCE 2
OUTPUT FUNCTION 2
OUTPUT HYSTERESIS 2
OUTPUT PRESELECTION 2

Menu / Parameter
GENERAL MENU
FILTER
MIN MAX CHANNEL
DIAGNOSIS SETUP
ADJUSTMENT MENU
TCI BRIDGE OFFSET
TCI BRIDGE GAIN
TEMP. COMP. (TCI)
BRIDGE SUPPLY ADJUST
TCI OFFSET INVERSION
TCI GAIN INVERSION
TEMP. SIMULATION
TEMP. SIM. VALUE
BRIDGE SUPPLY COMP.
BRIDGE SUPPLY REF.

4.1. Sensor Menu

The sensor-specific parameters are described in this menu.

SENSOR SUPPLY (sensor bridge supply)		
This parameter sets the supply of the sensor in V. The setting 5 corresponds to a voltage of approx. 5V (Readback via Index „40“, Subindex „19“ possible, calibration by parameter Bridge Supply Adjust)		
	3	Corresponds to a bridge supply voltage of 3V
	5	Corresponds to a bridge supply voltage of 5V (Default)
	10	Corresponds to a bridge supply voltage of 10V
SENSOR GAIN (sensor gain)		
This parameter sets the amplification of the bridge voltage. A setting of Gain = 0, 1, 2, 3, 4 results a gain of 1, 2, 4, 8, 16.		
	0	+/-80 mV Corresponds to a range of +/- 80mV (Default)
	1	+/-40 mV Corresponds to a range of +/- 40mV
	2	+/-20 mV Corresponds to a range of +/- 20mV
	3	+/-10 mV Corresponds to a range of +/- 10mV
	4	+/-5 mV Corresponds to a range of +/- 5mV
SENSOR OSR (sensor oversampling)		
This parameter sets the oversampling of the bridge voltage. Oversampling doubles with each level. The larger the oversampling value, the more accurate the read value. The total time can be read out with Index „661“, Subindex „0“ in ms and is influenced by the parameters Sensor OSR and Filter.		
	0	Smallest OSR -Value (Default)
	12	Largest OSR -Value
SENSOR OFFSET (sensor distance)		
The offset of the bridge voltage is set with this parameter. This parameter is also used with the tara function of the inputs or system command and is therefore overwritten but not saved permanently. The offset can be set permanently with an additional "Store Eeprom" command.		
	-10000	Smallest Offset-Value
	0	Default-Value
	+10000	Largest Offset-Value
SENSOR RESISTOR (sensor-resistance)		
This parameter is used to set the bridge resistance (input resistance) of the sensor. This value can be monitored by the 7379.5021. For example, if 350 ohms is set, an error will be triggered at $R < 175$ ohms and $R > 700$ ohms. (/2 or *2) („Index 40“, „Subindex 17“) If the value is set to 0, no error is reported.		
	0	Smallest Resistor-Value
	350	Default-Value
	10000	Largest Resistor-Value

Continuation „Sensor Menu“:

SENSOR SENSITIVITY (sensor sensitivity)			
This parameter is used to set the sensitivity (mV/V) of the sensor. This parameter is only used for certain billing types.			
	0.100	Smallest Sensitivity-Value	
	1.000	Default-Value	
	20.000	Largest Sensitivity Value	
SENSOR VOLTAGE (sensor-voltage)			
This parameter is used to set the bridge voltage conversion together with the Sensor Digit parameter. This parameter is only used for certain billing types.			
	1	Smallest Voltage Value	
	1000	Default-Value	
	99999	Largest Voltage-Value	
SENSOR DIGIT (sensor-unit)			
This parameter is used to set the bridge voltage conversion together with the Sensor Voltage parameter. This parameter is only used for certain billing types.			
	1	Smallest Digit-Value	
	1000	Default-Value	
	99999	Largest Digit-Value	
SENSOR CORRECTION (sensor-correctionr)			
A correction can be set with this parameter. This parameter is only used for certain billing types.			
	0.990	Smallest Correction Value	
	1.000	Default-Value	
	1.100	Largest Correction-Value	
SENSOR POLARITY (sensor polarity)			
An inversion can be set with this parameter. A positively measured bridge voltage can be converted into a negative one using the parameter. (tension and pressure with the appropriate sign)			
	0	NOT INVERTED	Pressure (Default)
	1	INVERTED	Tension

4.2. Digital Input Menu

The parameters for the digital inputs are described in this menu.

INPUT 1 CONFIG (characteristic input 1)			
This parameter defines the switching behavior for "Ctrl. Input 1".			
0	ACTIVE LOW	Active at „LOW“ (static)	
1	ACTIVE HIGH	Active at „HIGH“ (static)	
2	RISING EDGE	Activate at rising edge (dynamic)	
3	FALLING EDGE	Activate at falling edge (dynamic)	

INPUT 1 ACTION (funktion input 1)			
This parameter defines the function of the input "Ctrl. In 1".			
0	NO	No function.	
1	TARA	Tara for bridge voltage (zeroing).	(d) (s)
2	LOCK RELEASE 1	Reset latch for output 1.	(d) (s)
3	LOCK RELEASE 2	Reset latch for output 2.	(d) (s)
4	LOCK RELEASE 1+2	Reset latch for output 1+2.	(d) (s)
5	CLEAR MIN/MAX VALUES	Reset of the Min. / Max. Values.	(d) (s)
6	QUIT. OVERCURRENT	Acknowledgment after overcurrent error message. (>50mA).	(d) (s)



(s) = statistical characteristic (level evaluation)
INPUT CONFIG must be set to ACTIVE LOW/HIGH

(d) = dynamical characteristic (edge evaluation)
INPUT CONFIG must be set to RISING/FALLING EDGE

INPUT 2 CONFIG	
This parameter defines the switching characteristics of the input "Ctrl. In 2". See parameter INPUT 1 CONFIG.	

INPUT 2 ACTION	
This parameter defines the function of the input "Ctrl. In 2". See parameter INPUT 1 ACTION	

INPUT 3 CONFIG	
This parameter defines the switching characteristics of the input "Ctrl. In 3". See parameter INPUT 1 CONFIG.	

INPUT 3 ACTION	
This parameter defines the function of the input "Ctrl. In 3". See parameter INPUT 1 ACTION.	

4.3. Digital Output Menu

The parameters for the digital outputs are described in this menu.

OUTPUT POLARITY (changeover of the output polarity of both outputs) This parameter defines the switching state for both outputs.	
0	No inversion of both outputs. (Output = HIGH if condition met)
1	Switching output 1 is inverted. (Output = LOW if condition met)
2	Switching output 2 is inverted. (Output = LOW if condition met)
3	Switching output 1 and 2 are inverted. (Output = LOW if condition met)

OUTPUT LOCK (activation of "locking" of both switching outputs) This parameter defines whether a self-retaining function should be activated for the switching outputs.	
0	No latching of both outputs.
1	Latching for switching output 1 is activated.
2	Latching for switching output 2 is activated.
3	Self-retaining for switching output 1 and 2 is activated.

OUTPUT SOURCE 1 (Reference source for switching output 1) This parameter defines the reference source for switching output 1		
0	DIRECT BRIDGE RESULT	The reference source is the directly converted measurement result.
1	SCALED BRIDGE RESULT	The reference source is the converted measurement result.

Continuation „Digital Output Menu“:

OUTPUT FUNCTION 1 (switching condition for switching output 1)		
Switching condition for output 1. Output switches according to the following condition:		
0	$ \text{RESULT} \geq \text{PRES} $	Absolute value of the selected source is greater or equal absolute value of PRESELECTION 1 With HYSTERESIS 1 not equal 0 the following switching condition is applied: Selected source \geq PRESELECTION 1 \rightarrow ON, Selected source $<$ PRESELECTION 1 – HYSTERESIS 1 \rightarrow OFF
1	$ \text{RESULT} \leq \text{PRES} $	Absolute value of the selected source is less or equal absolute value of PRESELECTION 1. With HYSTERESIS 1 not equal 0 the following switching condition is applied: selected source \leq PRESELECTION 1 \rightarrow ON, selected source $>$ PRESELECTION 1 + HYSTERESIS 1 \rightarrow OFF
2	$ \text{RESULT} = \text{PRES} $	Absolute value of the selected source is equal absolute value of PRESELECTION A range (Preselection +/- ½ Hysteresis) can be defined and monitored in conjunction with the hysteresis. With HYSTERESIS 1 not equal 0 the following switching condition is applied: selected source $>$ PRESELECTION 1 + ½ HYSTERESIS 1 \rightarrow OFF, selected source $<$ PRESELECTION 1 - ½ HYSTERESIS 1 \rightarrow OFF
3	RESULT \geq PRES	Selected source is greater or equal PRESELECTION 1 With HYSTERESIS 1 not equal 0 the following switching condition is applied: selected source \geq PRESELECTION 1 \rightarrow ON, selected source $<$ PRESELECTION 1 – HYSTERESIS 1 \rightarrow OFF
4	RESULT \leq PRES	Selected source is less or equal PRESELECTION 1 With HYSTERESIS 1 not equal 0 the following switching condition is applied: selected source \leq PRESELECTION 1 \rightarrow ON, selected source $>$ PRESELECTION 1 + HYSTERESIS 1 \rightarrow OFF
5	RESULT = PRES	Selected source is equal PRESELECTION 1. A range (Preselection +/- ½ Hysteresis) can be defined and monitored in conjunction with the hysteresis. With HYSTERESIS 1 not equal 0 the following switching condition is applied: selected source $>$ PRESELECTION 1 + ½ HYSTERESIS 1 \rightarrow OFF, selected source $<$ PRESELECTION 1 - ½ HYSTERESIS 1 \rightarrow OFF
6	ERROR	Collective error message. Switching output switches as soon as an "Error" or "Warning" is pending. (At least one bit in the diagnosis byte is set.)
7	OFF	Switching output 1 is permanently deactivated.

OUTPUT HYSTERESIS 1 (hysteresis 1)		
Hysteresis for defining the switch-off point for the switching condition of switching output 1.		
	0	No switching hysteresis
	...	
	9999	Switching hysteresis of 99999

OUTPUT PRESELECTION 1 (preselection / switching point 1)		
	-9999	Smallest value
	1000	Default value
	+9999	Highest value

Continuation „Digital Output Menu“:

OUTPUT SOURCE 2 (Reference source for switching output 2)		
This parameter defines the reference source for switching output 2		
0	DIRECT BRIDGE RESULT	The reference source is the directly converted measurement result.
1	SCALED BRIDGE RESULT	The reference source is the converted measurement result.

OUTPUT FUNCTION 2 (switching condition for switching output 2)		
Switching condition for output 2. Output switches according to the following condition:		
0	$ RESULT \geq PRES $	Absolute value of the selected source is greater or equal absolute value of PRESELECTION 2 With HYSTERESIS 1 not equal 0 the following switching condition is applied: Selected source \geq PRESELECTION 2 \rightarrow ON, Selected source $<$ PRESELECTION 2 – HYSTERESIS 2 \rightarrow OFF
1	$ RESULT \leq PRES $	Absolute value of the selected source is less or equal absolute value of PRESELECTION 2. With HYSTERESIS 2 not equal 0 the following switching condition is applied: selected source \leq PRESELECTION 2 \rightarrow ON, selected source $>$ PRESELECTION 2 + HYSTERESIS 2 \rightarrow OFF
2	$ RESULT = PRES $	Absolute value of the selected source is equal absolute value of PRESELECTION A range (Preselection +/- ½ Hysteresis) can be defined and monitored in conjunction with the hysteresis. With HYSTERESIS 2 not equal 0 the following switching condition is applied: selected source $>$ PRESELECTION 2 + ½ HYSTERESIS 2 \rightarrow OFF, selected source $<$ PRESELECTION 2 - ½ HYSTERESIS 2 \rightarrow OFF
3	RESULT \geq PRES	Selected source is greater or equal PRESELECTION 2 With HYSTERESIS 2 not equal 0 the following switching condition is applied: selected source \geq PRESELECTION 2 \rightarrow ON, selected source $<$ PRESELECTION 2 – HYSTERESIS 2 \rightarrow OFF
4	RESULT \leq PRES	Selected source is less or equal PRESELECTION 2 With HYSTERESIS 2 not equal 0 the following switching condition is applied: selected source \leq PRESELECTION 2 \rightarrow ON, selected source $>$ PRESELECTION 2 + HYSTERESIS 2 \rightarrow OFF
5	RESULT = PRES	Selected source is equal PRESELECTION 2. A range (Preselection +/- ½ Hysteresis) can be defined and monitored in conjunction with the hysteresis. With HYSTERESIS 2 not equal 0 the following switching condition is applied: selected source $>$ PRESELECTION 2 + ½ HYSTERESIS 2 \rightarrow OFF, selected source $<$ PRESELECTION 2 - ½ HYSTERESIS 2 \rightarrow OFF
6	ERROR	Collective error message. Switching output switches as soon as an "Error" or "Warning" is pending. (At least one bit in the diagnosis byte is set.)
7	OFF	Switching output 2 is permanently deactivated.

OUTPUT HYSTERESIS 2 (hysteresis 2)		
Hysteresis for defining the switch-off point for the switching condition of switching output 2		
	0	No switching hysteresis
	...	
	9999	Switching hysteresis of 99999

Continuation „Digital Output Menu“:

OUTPUT PRESELECTION 2 (preselection / switching point 2)		
	-9999	Smallest value
	1000	Default value
	+9999	Highest value

4.4. General Menu

The general parameters for this signal converter are described in this menu.

FILTER		
This parameter provides a better filtering of the DMS sensor supply readback. The filter time is doubled with each increase in value. .The longer the filter time, the more accurate the read value. The total reading time is influenced by parameter Sensor OSR and Filter.		
	0	Smallest Filter-Value (Default)
	9	Highest Filter-Value

MIN MAX CHANNEL			
Selection of the analog input for min/max value monitoring. With the Min/Max value monitoring the fluctuation range of the signal can be determined, an increase of the OSR or the filter can reduce the fluctuations.			
	0	READ BACK VOLTAGE SUPPLY	Sensor supply voltage read back (raw value-
	1	BRIDGE RESULT	Bridge voltage sensor (raw value)
	2	CURRENT RESULT	Current measurement sensor (raw value)

DIAGNOSIS SETUP			
This parameter can be used to specify which " <u>events</u> " are to be generated by the device.			
Corresponding bit = 1 → associated event is generated as soon as the event is pending (appears) or is no longer pending (disappears).			
Corresponding bit = 0 → associated event is <u>not</u> generated.			
Min:		0x00	
Default:		0x00	
Max:		0x0F	
	Bit 0	0	Overcurrent (> 50mA) detected.
	Bit 1	0	Calculated resistance is above the set range.
	Bit 2	0	Calculated resistance is below the set range.
	Bit 3	0	Device supply undervoltage (< 17 V)
	Bit 4	0	Reserved
	Bit 5	0	Reserved
	Bit 6	0	Reserved
	Bit 7	0	Reserved



Notice:

The "Diagnosis Byte" in the cyclic process data (byte 15) always shows which events are currently pending. Only the associated events can be switched on or off with the appropriate setting of this parameter.

4.5. Adjustment Menu

In this menu, the specific parameters for the fine adjustments of the signal converter are described.

TCI BRIDGE OFFSET (fine adjustment of the offset temperature difference) The temperature difference can be read out via Index "662", Subindex "0" . The TCI OFFSET INVERSION parameter can be used to determine whether the value is added or subtracted.		
	0.5000	Smallest TCI Bridge Offset-Value
	1.0000	Default
	1.5000	Highest TCI Bridge Offset-Value
TCI BRIDGE GAIN (fine adjustment of the gain temperature amplification) The temperature gain can be read out via Index "663", Subindex "0" . The TCI GAIN INVERSION parameter can be used to determine whether the value has an amplifying or weakening effect.		
	0.90000	Smallest TCI Bridge Gain-Value
	1.00000	Default
	1.10000	Highest TCI Bridge Gain-Value
TEMP. COMP. (TCI) (temperature compensation) Temperature compensation for the analog input (bridge voltage).		
	0	Compensation of offset and gain (TCI bridge offset / gain active) (Default)
	1	Offset compensation only (TCI bridge offset active)
	2	Gain compensation only (TCI bridge gain active)
	3	No compensation
BRIDGE SUPPLY ADJUST (Gain setting for the measurement of the MEA.) The setting affects the resistance calculation. If the bridge voltage is converted (Recalculated), the converted value becomes more accurate when adjusted. The comparison can be carried out by reading out Index "40", Subindex "19" .		
	0.8000	Smallest Bridge Supply Adjust-Value
	1.0000	Default
	1.2000	Highest Bridge Supply Adjust Value

Continuation „Adjustment Menu“:

TCI OFFSET INVERSION		
See parameter TCI Bridge Offset		
	0	weaken(Default)
	1	amplifying

TCI GAIN INVERSION		
See parameter TCI Bridge Gain		
	0	weaken (Default)
	1	amplifying

TEMP. SIMULATION		
If the parameter TEMP. SIMULATION = 0 is set, the internal temperature sensor is used. If the parameter is set to "1", instead of the internal temperature sensor, the parameter TEMP. SIM. VALUE used. This allows the temperature to be simulated and the calculation of the temperature compensation to be checked.		
	0	OFF: internal temperature sensor (Default)
	1	ON: Parameter TEMP. SIM. VALUE

TEMP. SIM. VALUE (simulation of the temperature)		
The value 870 corresponds to +60°, the value 1140 corresponds to +20° and the value 1412 corresponds to -20°. The current temperature can be read out via Index "665", Subindex "0".		
	870	+60°
	1140	+20° (Default)
	1412	-20°

BRIDGE SUPPLY COMP. (bridge supply compensation)		
If Source = direct is selected, Compensation = 2 can be selected. If Source = calculated is selected, Compensation = 0 can be selected.		
	0	No bridge voltage compensation (Default)
	1	Compensation (increasing Supply Voltage not amplifying)
	2	Compensation (increasing Supply Voltage not mitigating)

BRIDGE SUPPLY REF. (bridge supply reference)		
The setting of this parameter corresponds to the voltage value of the bridge supply in mV.		
	2000	Smallest Bridge Supply Ref.-Value
	5000	Default
	11000	Highest Bridge Supply Ref.-Value

5. Commissioning

5.1. Basic setting of the strain gauge sensor

For connection and wiring, see connection example for strain gauge sensor. After connection, the parameters "Sensor Supply", "Sensor Gain", "Sensor OSR", "Sensor Resistor" and "Filter" can be set. The "Sensor Supply" parameter corresponds to the supply voltage of the strain gauge sensor, which can be found in the sensor's operating instructions. Values from 3 (3V) to 10 (10V) can be set for the "Sensor Supply" parameter. **Index "40", Subindex "19"** is used to read back the supply voltage in mV, the measurement can be calibrated using the "Bridge Supply Adjust" parameter.

The value of the input resistance can also be found in the operating instructions for the sensor. This can be adopted for the "Sensor Resistor" parameter. The resistance value in ohms can be checked via **Index "40", Subindex "17"**. A wrong calibration of "Bridge Supply Adjust" leads to a wrong calculation. The "Sensor Gain" should be selected in such a way that the input voltage range is not exceeded at maximum load. With gain = 0 this is +/-80mV. This can be calculated approximately using a reference weight, for example.

The "Sensor OSR" parameter should be selected depending on the "Sensor Gain" so that the input fluctuation is as small as possible and the input is still dynamic enough. This also applies to the "Filter" parameter. The resulting read-in cycle time can be read out in ms via **Index "661", Subindex "0"**.

With the "Sensor Polarity" parameter, a negative deflection can be changed into a positive one. Thus, the user can provide tension and compression with the appropriate sign. Wiring errors, open connections and short circuits on the sensor can be detected by the corresponding bit in the diagnostics byte of the cyclic process data or signaled by an output. (Read back supply voltage and calculated resistance value)



Attention:

Check whether the sensor is designed for the programmed supply voltage. (data sheet sensor: supply voltage) Check that the input voltage range is within the maximum load of the sensor. (Data sheet sensor: nominal value [mV/V] x supply voltage)

5.2. Easiest setting

The simplest setting for the digital outputs or for further processing with a higher-level controller is to use the directly converted bridge voltage ("DIRECT BRIDGE RESULT"). (Corresponds to **Index "40", Subindex "21"** or **byte 0..3** of the cyclic process data). To do this, the parameters "Output Source 1" or "Output Source 2" must be set to 0 for the digital outputs.

The following parameters must be adjusted for the strain gauge sensor:

"Sensor Supply" parameter:	Sensor data sheet -> Permitted supply voltage of the sensor
"Sensor Gain" parameter:	Sensor data sheet -> Working range of the sensor
"Sensor OSR" parameter:	Fluctuation in the measurement and dynamics of the change
"Sensor Resistor" parameter:	data sheet sensor -> input resistance

Einstellung mit Nullung:

Zeroing is necessary if forces act in both directions and the transition from e.g. tension and compression of the input variable is to be determined in the form of the sign.

The "Sensor Offset" parameter is decisive for zeroing. The unloaded strain gauge sensor can be zeroed using the "tara function" (via a digital input or by executing a "system command" via IO Link). The value read out via **Index "40", Subindex "21"** or via **byte 0..3** of the cyclic process data can also be transferred directly to the "Sensor Offset" register. Then the register shows zero. With the "tara function" using an input, the value is only temporarily stored, after a renewed power-up it must be zeroed again. If the "tara function" is carried out via a "system command" (**Index "2", Subindex "0", value: "160"**) via IO-Link, the value can also be changed by another subsequent "Store Eeprom" system command (**Index "2", Subindex "0", value: "168"**) can be stored non-volatile. Then the DMS sensor is loaded with a reference weight, a new value is displayed that corresponds to the reference weight. This value can now be converted into units for the digital outputs or for further processing in a higher-level controller. The transmitted value can be used to determine the resolution in relation to the reference weight and then also to optimize the "Sensor Gain" parameter. If the "Sensor Gain" parameter is changed, the "Sensor Offset" parameter must also be adjusted.

Example:

Index „40“, Subindex „21“:	25	with „Sensor Offset“ = 0, DMS unloaded.
Index „40“, Subindex „21“:	0	with „Sensor Offset“ = 25, DMS unloaded and zeroed.
Index „40“, Subindex „21“:	1000	with 5kg reference weight.

This means that the value must be 10000 for 50kg. If the digital output is to switch when the weight is greater than 40kg, the "Output Preselection" must be set to 8000.

Setting without zeroing:

Zeroing is not necessary if the input variable is not required as a reference for the forces, i.e. the acting forces cannot be read directly from the input variable. (e.g. value 531 -> 400g) Then the DMS sensor is loaded with a reference weight, a new value is displayed that corresponds to the reference weight. This value can now be converted into units for the digital outputs. The transmitted value can be used to determine the resolution in relation to the reference weight and then also to optimize the "Sensor Gain" parameter.

Example:

Index „40“, Subindex „21“: 25 with „Sensor Offset“ = 0, DMS unloaded

Index „40“, Subindex „21“: 1025 with 5kg reference weight

This means that the value must be 10025 for 50kg.

(1025 – 25 = 1000 corresponds to 5kg -> 50kg = 10000, -> transmitted value at 50kg = 10025)

If the digital output is to switch when the weight is greater than 40kg, the "Output Preselection" must be set to 8025.

5.3. Conversion to sensor units

A conversion into sensor units is necessary if an external conversion in a higher-level controller is to be dispensed with. This type of conversion is also necessary if a reference load or reference weight is to be dispensed with for standardization. With the help of the "Sensor Sensitivity", "Sensor Voltage", "Sensor Digits" and "Sensor Correction" parameters, the read sensor value can be converted into units such as N or kg. A reference load or a reference weight is required for the "Sensor Correction" parameter, with which the displayed value can be corrected. The "Output Source X" parameter must be set to 1 for the digital outputs. The "Sensor Offset" parameter is decisive for zeroing. The unloaded DMS sensor can be zeroed using the "tara function". The displayed value can also be transferred directly to the "Sensor Offset" register. Then the transmitted value shows zero. With the "tara function" using an input, the value is only temporarily stored, after a renewed power-up it must be zeroed again. If the "tara function" is carried out via a "system command" (Index "2", Subindex "0", value: "160") via IO-Link, the value can also be changed by another subsequent "Store Eeprom" system command (Index "2", Subindex "0", value: "168") can be stored non-volatile. The Sensitivity parameter corresponds to the sensitivity (mV/V) of the strain gauge sensor, which can be found in the sensor's operating instructions. The standard load or standard force can also be found here. (e.g. 2mV/V @ 100N or 10,194kg)

"Sensor Sensitivity" parameter = 2.000	see data sheet
"Output Source X" parameter = 1	converted bridge result
Sensor Voltage parameter = 1000	Gain = 1
"Sensor Digits" parameter = 10194	conversion in kg, number of digits in g
"Sensor Correction" parameter = 1000	No correction Sensor
Offset parameter = 133	-> 0
With a reference weight of 200g	-> entry size 54
Conversion	-> 197..201

Attention: Here a multiplication with a factor of 4 takes place, it would be better to increase the gain to 4 if you want an accuracy of 1g. The "Sensor Correction" parameter can be used to adjust the conversion to a small degree. A 1% adjustment is made by 990 or 1010. The calculation can be checked via **Index "40", Subindex "20" or byte 4..7** of the cyclic process data. The transmitted value can be used to determine the resolution in relation to the reference weight and then also to optimize the "Sensor Gain" parameter. If the "Sensor Gain" parameter is changed, the "Sensor Offset" parameter must also be adjusted.

5.4. Digital Input

The digital inputs can be used to trigger commands. Here, for example, zeroing can take place via an input. Resetting the latching of an output, acknowledgment after a short circuit and cleaning up the min/max value monitoring is also possible.

5.5. Digital Output

The digital outputs are used to detect states. For example, if the force exceeds a certain value, the output is set. Falling below can also be detected. The functions can be used for forces in one direction, or in both. A hysteresis can also be programmed, as well as a self-retaining whose cancellation is only triggered again by an input or "System Command".

5.6. Other optional settings

5.6.1. Examination of the analog read in values

With the help of the "Min Max Channel" parameter, various read-in values can be examined for their scatter. Minimum and maximum values can be reset by triggering the corresponding "System Commands" or via a digital input. The deviations can be made visible via **Index "659", Subindex "0"** (maximum) and via **Index "660", Subindex "0"** (minimum). If the values fluctuate too much, the "Sensor OSR" parameter or the "Filter" must be increased.

5.7. Calibration of the MEA readback

Both analog readbacks of the bridge voltage can be calibrated. To do this, an external multimeter must be connected and then compared in relation to the readback (via **Index "40", Subindex "19"**). Calibration is possible via the "Bridge Supply Adjust" parameter. Adjustment is necessary to increase the accuracy of the calculated resistance value and when using the conversion to sensor units. The setting must be made after selecting the "Sensor Supply" parameter.

5.8. Calibration of analog input BRI / DMS

Both analog inputs can only be calibrated in relation to the temperature characteristics. These settings linearly correct the "Offset" and the "Gain" depending on the temperature.

5.8.1. Input stage calibration

With the help of various parameters, the input stage can be optimized in relation to the temperature. With the parameter "Temp. Simulation" the temperature for the device can be simulated. This makes it easy to determine the influence of individual variables. First the offset correction has to take place and then the gain correction.

Example offset correction:

Voltage at input :	0 mV
"Temp. Comp. (TCI)" = 1	temperature compensation of offset
"Temp. Simulation" = 1	simulation active
"Temp. Sim. Value" = 1412	Simulation with -20°
Index "665", Subindex "0"	-20 (temperature read back)
Parameter "Sensor Gain" = 0	Gain = 0 selected
Parameter "TCI Bridge Offset 1" = 1.0000	default
Parameter "TCI Offset Inversion" = 0	inversion
Index "662", Subindex "0"	-8 (correction read back at 40K)
Index "658", Subindex "0"	offset changes e.g. from 21 to 29 at In Temp.C = 1/3

With **Index "658", Subindex "0"** you can directly see the influence with and without temperature offset compensation by switching. The correction is zero at 20° and is the reference point. The offset is reduced by 8 increments at -20°. At 40K the offset is corrected by 8 increments. Changing the parameter "TCI Offset Inversion" = 1 does not change **Index "662", Subindex "0"**, but **Index "658", Subindex "0"**. Here the offset is increased by 8 increments. The "Sensor Gain" parameter is also included in the calculation; with Gain = 4, instead of -8, -132 increments are compensated. The 8 increments can be increased or decreased using the "TCI Bridge Offset" parameter.

The following relationship applies:

Correction = (Temperature -20) x (Gain + 1) x (Gain + 1) x 2063 / TCI Bridge Offset

Correction (Temperature = -20°, Gain = 0, TCI Bridge Offset = 1.0000) = -40 x 2063 / 10000 = -8

With the standard settings, there is sufficient optimization for the entry level.

Example gain correction:

Voltage at input:	5 mV
"Temp. Comp. (TCI)" = 0	Temperature compensation of offset and gain
"Temp. Simulation" = 1	simulation active
"Temp. Sim. Value" = 1412	Simulation with -20°
Index "665", subindex "0"	-20 (temperature read back)
"Sensor Gain" parameter = 0	Gain = 0 selected
"TCI Bridge Gain" parameter = 1.00000	default
"TCI Gain Inversion" parameter = 0	inversion
Index "663", Subindex "0"	(correction read back at 40K)
Index "664", Subindex "0"	Gain changes by a factor at In Temp.C = 0/3

The following relationship applies:

Correction Factor = ((Temperature -20) x (Gain + 1) + 100000) / TCI Bridge Gain

Correction (Temperature = -20°, Gain = 0, TCI Bridge Gain = 1.00000) = -40 + 100000 / 100000 = 0,9996

With the standard settings, there is sufficient optimization for the entry level.

5.8.2. Calibration of the input stage and the DMS sensor

With the help of various parameters, the input stage and the connected DMS can be optimized with regard to temperature. The condition is that the DMS and the device are exposed to approximately the same temperatures. Here, for example, the temperature-dependent offset of the strain gauge can be taken into account in addition to the input stage. First the offset correction has to take place and then the gain correction.

5.8.3. Monitor codes for calibration

Calibration can be simplified with the help of different register values.

Index „658“, Subindex „0“:	Input with offset compensation (Bridge Value (Raw Value))
Index „662“, Subindex „0“:	Offset correction input read back (Read Back Offsetcorrection)
Index „663“, Subindex „0“:	Gain compensation factor of the input (Factor of the Gain Compensation)
Index „664“, Subindex „0“:	Input with offset, offset and gain compensation (Result with Offset, Offset- and Gain Compensation)
Index „665“, Subindex „0“:	Read back temperature (Temperature)

6. Attachment

6.1. Parameter / serial codes

#	Menu	Name	Ser.Code	Min	Max	Default
1	SENSOR MENU	SENSOR SUPPLY	00	3	10	5
2	SENSOR MENU	SENSOR GAIN	01	0	4	0
3	SENSOR MENU	SENSOR OSR	02	0	12	0
4	SENSOR MENU	SENSOR OFFSET	03	-10000	10000	0
5	SENSOR MENU	SENSOR RESISTOR	04	0	10000	350
6	SENSOR MENU	SENSOR SENSITIVITY	05	100	20000	1000
7	SENSOR MENU	SENSOR VOLTAGE	06	1	99999	1000
8	SENSOR MENU	SENSOR DIGIT	07	1	99999	1000
9	SENSOR MENU	SENSOR CORRECTION	08	900	1100	1000
10	SENSOR MENU	SENSOR POLARITY	09	0	1	0
11	DIGITAL INPUT MENU	INPUT 1 CONFIG	A0	0	3	2
12	DIGITAL INPUT MENU	INPUT 1 FUNCTION	A1	0	6	0
13	DIGITAL INPUT MENU	INPUT 2 CONFIG	A2	0	3	2
14	DIGITAL INPUT MENU	INPUT 2 FUNCTION	A3	0	6	0
15	DIGITAL INPUT MENU	INPUT 3 CONFIG	A4	0	3	2
16	DIGITAL INPUT MENU	INPUT 3 FUNCTION	A5	0	6	0
17	DIGITAL OUTPUT MENU	OUTPUT POLARITY	B0	0	3	0
18	DIGITAL OUTPUT MENU	OUTPUT LOCK	B1	0	3	0
19	DIGITAL OUTPUT MENU	OUTPUT SOURCE 1	B2	0	1	0
20	DIGITAL OUTPUT MENU	OUTPUT FUNCTION 1	B3	0	7	7
21	DIGITAL OUTPUT MENU	OUTPUT HYSTERESIS 1	B4	0	9999	0
22	DIGITAL OUTPUT MENU	OUTPUT PRESELECTION 1	B5	-9999	9999	1000
23	DIGITAL OUTPUT MENU	OUTPUT SOURCE 2	B6	0	1	0
24	DIGITAL OUTPUT MENU	OUTPUT FUNCTION 2	B7	0	7	7
25	DIGITAL OUTPUT MENU	OUTPUT HYSTERESIS 2	B8	0	9999	0
26	DIGITAL OUTPUT MENU	OUTPUT PRESELECTION 2	B9	-9999	9999	1000
27	GENERAL MENU	FILTER	D0	0	9	0
28	GENERAL MENU	MIN MAX CHANEL	D1	0	2	0
29	GENERAL MENU	DIAGNOSIS SETUP	D2	0	15	0
30	GENERAL MENU	FACTORY SETTINGS	D3	0	1	0
31	ADJUSTMENT MENU	TCI BRIDGE OFFSET	E0	5000	15000	10000
32	ADJUSTMENT MENU	TCI BRIDGE GAIN	E1	90000	110000	100000
33	ADJUSTMENT MENU	TEMP. COMP. (TCI)	E2	0	3	0
34	ADJUSTMENT MENU	BRIDGE SUPPLY ADJUST	E3	8000	12000	10000
35	ADJUSTMENT MENU	TCI OFFSET INVERSION	E4	0	1	0

36	ADJUSTMENT MENU	TCI GAIN INVERSION	E5	0	1	0
37	ADJUSTMENT MENU	TEMP. SIMULATION	E6	0	1	0
38	ADJUSTMENT MENU	TEMP. SIM. VALUE	E7	870	1412	1140
39	ADJUSTMENT MENU	BRIDGE SUPPLY COMP.	E8	0	1	0
40	ADJUSTMENT MENU	BRIDGE SUPPLY REF.	E9	0	11000	5000

6.2. Dimensions

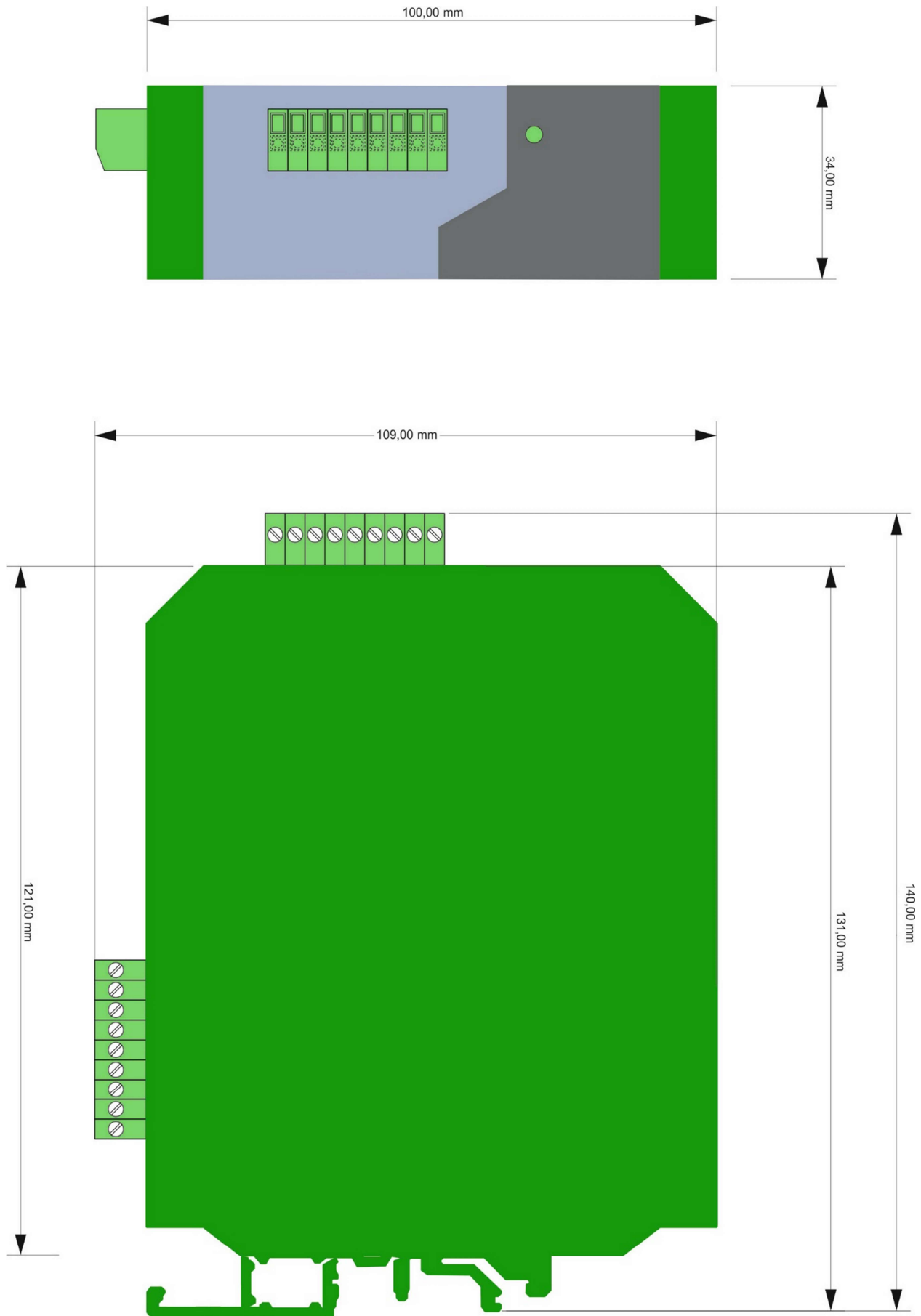

6.3. Technical Specifications

Technical Specifications:		
Connections:	Connector type:	screw terminal, 1,5 mm ² / AWG 16
Power Supply:	Input voltage: Protection circuit: Consumption:	24 VDC (18 ... 30 VDC) through IO-Link reverse polarity protection approx. 75 mA (unloaded)
DMS Input:	Anzahl: Konfiguration: Empfindlichkeit: Auflösung: Genauigkeit: DMS Versorgungsspannung: Ausgangsstrom:	1 mit Rücklesung Spannung +/- 5mV, +/-10mV, +/-20mV, +/-40mV, +/-80mV 16 Bit +/- 0.01% / 10K 3-10 VDC max. 50 mA
Control inputs: (with option „CO“)	Number of inputs: Format: Frequency: Reaction time: Transmission Time (IO Link): Load:	3 HTL, PNP (Low 0 ... 3 V, High 9 ... 30 V) max. 1 kHz 1 ms Approx. 2 ms – (Cyclus Time IO – Link) max. 2 mA at 24VDC
Control outputs: (with option „CO“)	Number of outputs: Format: Output current: Reaction time: Transmission Time (IO Link):	2 5 ... 30 V (depends on the Com+ voltage), PNP max. 100 mA each output min. 1 ms (Depending on „Sampling Time“ and „Filter“ setting) Approx. 2 ms – (Cyclus Time IO – Link)
IO-Link:	Module / Specification: Bitrate: Port Class: Cyclus time: Data width:	Device / IO Link V1.1 COM 3 (230,4 kBit / s) Typ A min. 2 ms 16 Byte (14 Byte (Processdata) + 1Byte („CO“ Status) + 1 Byte (Diagnosis data))
Indicators:	Number of indicators: Function:	1 LED 1 x green for “ready for operate” state or actual “IO Link state” (with option “CO”)
Housing:	Material: Mounting: Dimensions (w x h x d): (without connectors) Dimensions (w x h x d): (inclusive connectors) Weight: Protection:	Plastic 35 mm top hat rail (according to EN 60715) 34 x 100 x 131 mm / 1.34 x 3.94 x 5.16 inches 34 x 109 x 140 mm / 1.34 x 4.65 x 5.51 inches approx. 160 g IP20
Ambient temperature:	Operation: Storage:	-20 °C ... +60 °C not condensing -25 °C ... +70 °C
Environmental conditions:	Altitude: Humidity: Degree of pollution:	max. 2000 meter above sea level max. 80% relative humidity to 30 °C 2
Failure rate:	MTBF in years: (continuous operation at 60 °C)	7379.5021: 92,9 a 7379.5021/CO: 84,9 a
Conformity and standards:	EMV 2014/30/EU: RoHS (II) 2011/65/EU RoHS (III) 2015/863:	EN 61326-1: 2013 for industrial location EN 55011: 2016 + A1: 2017 + A11: 2020 Class A EN IEC 63000: 2018