

MATERIAL

- **GN 227.1:** pressed steel, epoxy resin coating, black colour, RAL 9005, matte finish.
- **GN 227.4:** AISI 316L pressed stainless steel, sandblasted matte finish.

STANDARD EXECUTIONS

- **GN 227.1-B:** welded hub, H9 reamed hole.
- **GN 227.1-V:** welded hub, H11 square hole.
- **GN 227.4-B:** welded hub, H9 reamed hole.
- **GN 227.4-V:** welded hub, H11 square hole.

SPECIAL EXECUTIONS ON REQUEST

Handwheels with keyway in compliance with DIN 6885/1 tolerance P9 (see page A-15).

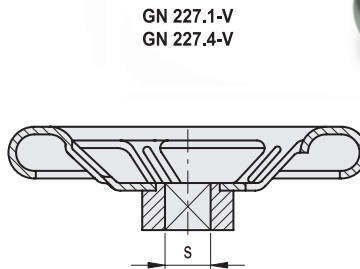
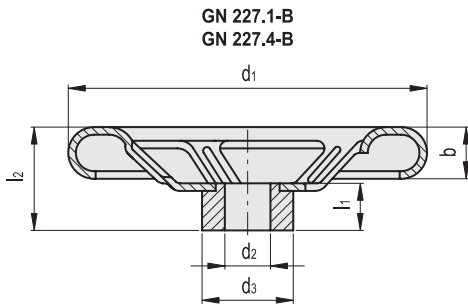

GN 227.1

Code	Description	d1	d2 H9	sH11	d3	b	l1	l2	Spokes no.	Thickness stainless steel	⚖️
GN.25211	GN 227.1-125-B11-SW	125	11	-	30	18	18	29	3	1.5	300
GN.25221	GN 227.1-160-B12-SW	160	12	-	30	22	20	37	4	1.5	400
GN.25231	GN 227.1-200-B14-SW	200	14	-	40	22	24	46	4	2.5	800
GN.25241	GN 227.1-250-B17-SW	250	17	-	45	30	28	52	5	2.5	1450
GN.25251	GN 227.1-315-B19-SW	315	19	-	55	35	33	64	5	2.5	2350
GN.25257	GN 227.1-400-B24-SW	400	24	-	65	40	38	82	5	3	4140
GN.25215	GN 227.1-125-V11-SW	125	-	11	30	18	18	29	3	1.5	280
GN.25225	GN 227.1-160-V12-SW	160	-	12	30	22	20	37	4	1.5	400
GN.25235	GN 227.1-200-V14-SW	200	-	14	40	22	24	46	4	2.5	785
GN.25245	GN 227.1-250-V17-SW	250	-	17	45	30	28	52	5	2.5	1455
GN.25255	GN 227.1-315-V19-SW	315	-	19	55	35	33	64	5	2.5	2280
GN.25259	GN 227.1-400-V24-SW	400	-	24	65	40	38	82	5	3	4070

GN 227.4

Code	Description	d1	d2 H9	sH11	d3	b	l1	l2	Spokes no.	Thickness stainless steel	⚖️
GN.25381	GN 227.4-160-B12-A	160	12	-	30	22	20	39	4	2	430
GN.25384	GN 227.4-200-B14-A	200	14	-	40	22	24	44	4	2.5	824
GN.25387	GN 227.4-250-B17-A	250	17	-	45	30	28	52	5	3	1477
GN.25401	GN 227.4-315-B19-A	315	19	-	55	36	33	64	5	3	2330
GN.25404	GN 227.4-400-B24-A	400	24	-	65	43	38	81	5	3	4210
GN.25382	GN 227.4-160-V12-A	160	-	12	30	22	20	39	4	2	428
GN.25385	GN 227.4-200-V14-A	200	-	14	40	22	24	44	4	2.5	824
GN.25398	GN 227.4-250-V17-A	250	-	17	45	30	28	52	5	3	1465
GN.25402	GN 227.4-315-V19-A	315	-	19	55	36	33	64	5	3	2100
GN.25405	GN 227.4-400-V24-A	400	-	24	65	43	38	81	5	3	4180



Operating elements