



# har-bus® HM female connector



## General information

Design	IEC 61076-4-101	
No. of contacts	55 - 220 signal (77 - 308 fully shielded); or customised	
Contact spacing	2,0mm	
Test voltage	750V AC	
Contact resistance	max. 20mOhm	
Insulation resistance	min. 10 <sup>10</sup> Ohm	
Working current	1A at 70°C	(see derating diagram)
Temperature range	-55°C ... +125°C	
Termination technology	press-in	
Clearance & creepage distance	0,6 mm each for free connector	
Insertion and withdrawal force	insertion force per contact:	0,75N max.
	withdrawal force per contact:	0,15N min.
Mating cycles	acc. to performance level, see table below	
UL file	E102079	
RoHS - compliant	Yes	
Leadfree	Yes	

## Insulator material

Material	PBT (thermoplastics, glass fiber reinforcement 30%)
Colour	RAL 7032 (grey)
UL classification	UL 94-V0
Material group acc. to IEC 60664-1	IIIa (175 ≤ CTI < 400)
NFF classification	I3, F4

## Contact material

Contact material	Copper alloy
Treatment contact zone	Bellcore recommended lubricant (PPE)
Plating press-in zone	Ni
Plating contact zone	acc. to performance level, see table below

performance level	mating cycles		plating contact zone
	acc. to IEC 61076-4-101	complementary acc. to IEC 61076-4-101	
1	500		<i>Au over Ni</i>
2	250		<i>Au over Ni</i>
NM30 (S4)		500	min. 0,76µm (30pinch) noble metal (alloy) over Ni
Au30		500	min. 0,76µm (30pinch) Au over Ni
Au50		500	min. 1,27µm (50pinch) Au over Ni

Standard plating options highlighted in *italic*, other plating options are available on request.

## Recommended configuration of plated through holes for press-in termination

In addition to the hot-air-level (HAL), other PCB surfaces are getting more important. Due to their different properties - such as mechanical strength and coefficient of friction - we recommend the following configuration of PCB through holes.

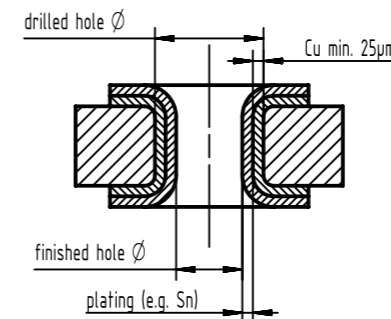

Tin plated PCB (HAL) acc. to EN 60352-5	Drilled hole Ø	0,7±0,02 mm
	Sn plated hole Ø	max. 15 µm
Chemical tin plated PCB	Drilled hole Ø	0,7±0,02 mm
	Sn plated hole Ø	min. 0,8µm
Gold /Nickel plated PCB	Drilled hole Ø	0,7±0,02 mm
	Ni plated hole Ø	3 - 7 µm
	Au plated hole Ø	0,05 - 0,12 µm
Silver plated PCB	Drilled hole Ø	0,7±0,02 mm
	Ag plated hole Ø	0,1 - 0,3 µm
Copper plated PCB (OSP)	Drilled hole Ø	0,7±0,02 mm
	plated hole Ø	0,60 - 0,65 mm

## Assembly instructions

It is highly recommended to use HARTING press-in tools to ensure a reliable press-in process. Please refer to the catalogue for tools, machines and further information about the press-in process.

## Circuit density

When using the specified diameter of the finished through hole according to IEC 61076-4-101 (0.6 ± 0.05mm) with an appropriate annular ring, the remaining distance between the rings is about 1mm.

Under the condition that the width of the track and the space between should be equal, two tracks of 0.2mm width or three tracks of 0.14mm width can be placed between two rings.

Typical designs are shown in the drawing on the right side.

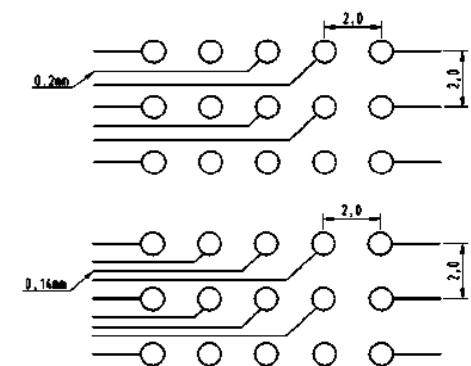

## Derating diagram acc. to IEC 60512-5 (Current carrying capacity)

The current carrying capacity is limited by maximum temperature of materials for inserts and contacts including terminals.

The current capacity curve is valid for continuous, non interrupted current loaded contacts of connectors when simultaneous power on all contacts is given, without exceeding the maximum temperature.

Control and test procedures according to DIN IEC 60512-5

Curve 1 shows raise in temperature  
Curve 2 shows nominal derating Date Name  
Curve 3 shows reduced values as per IEC512

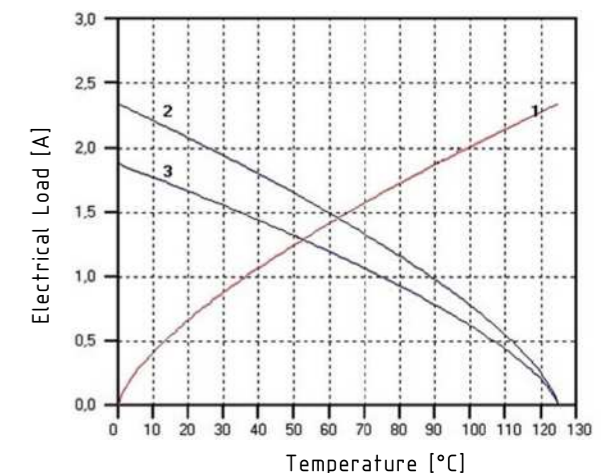

	All rights reserved	Created by	Inspected by	Standardisation	Date	State	
	Department EC PD - DE	STORCK	LEHNERT	HOFFMANN	2018-05-15	Final Release	
HARTING Electronics GmbH		Title				Doc-Key / ECM-Nr.	
D-32339 Espelkamp		har-bus® HM female connector				100580923/UGD/000/B 500000135160	
		Type	Number	Rev.		Page	
		DS	17002200101	B		1/1	