

Fibre optic diffuse reflection sensor

FT-50-V-V-M5/16

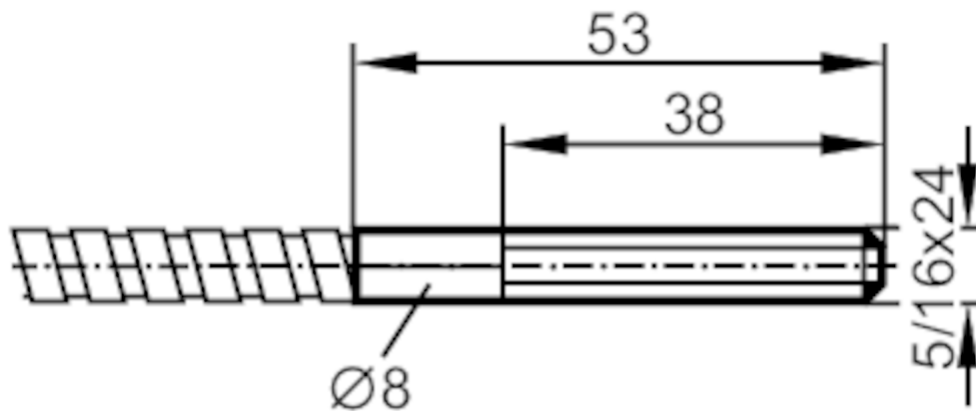

Application

Function principle	Diffuse reflection sensor
--------------------	---------------------------

Detection zone

Range with fibre optic amplifier type	OBF; ODF; OMF
---------------------------------------	---------------

OBF

Range fibre optics [mm]	150
-------------------------	-----

ODF

Range fibre optics [mm]	1
-------------------------	---

OMF

Range fibre optics [mm]	175
-------------------------	-----

Operating conditions

Ambient temperature [°C]	-58...315
--------------------------	-----------

E20822



Fibre optic diffuse reflection sensor

FT-50-V-V-M5/16

Mechanical data	
Weight [g]	126.5
Version of sensing head	straight
Total length [mm]	900
Min. bending radius [mm]	19
Fibre arrangement	⓪
Fibre material	glass
Fibre head material	stainless steel (1.4305 / 303)
Fibre sheath material	stainless steel (1.4305 / 303)
Accessories	
Accessories (supplied)	hexagon nuts: 2
	clamping rings: 2
	O-rings: 2
Remarks	
Pack quantity	1 pcs.