

PRESSURE COMPENSATION DEVICE SNAP-IN

DA 284 | IP66



Photo: Inside view

- > High degree of protection
- > Waterproof membrane

- > Easy to install due to snap-in action

Pressure differentials in enclosures with a high degree of protection are a result of internal and external temperature changes. In the case of negative pressure or partial vacuum, dust and humidity can enter the enclosure through the door seal. When the air inside the enclosure cools down, condensation may occur because the humidity cannot escape the enclosure. The easy-to-install pressure compensation device DA 284 provides compensation of pressure at a protection degree of IP66. Even with a slight overpressure, a waterproof membrane inside the plug allows the humidity to escape whilst blocking water and dirt from entering the enclosure.



TECHNICAL DATA

Mounting	Snap-In, mounting from outer side
Wall thickness	1 to 4 mm
Depth in enclosure	approx. 15 mm, according to wall thickness
Sealing	sealing gasket EPDM
Filter	waterproof membrane
Dimensions	Ø 70 x 33,5 mm
Fitting position	variable
Note	Material adheres to limit values in accordance with RoHS3

Installation: Make cut-out Ø 40+0,5 mm in enclosure wall for size M40. Attach pressure compensation element from the outer side of the enclosure (housing). Make sure that the hole is round and free of burrs. The sealing ring must be mounted on the outer side of the housing wall. Apply sufficient pressure so the five snap-in hooks fully engage. Snap-in pressure is easily adaptable to wall thickness of the enclosure.

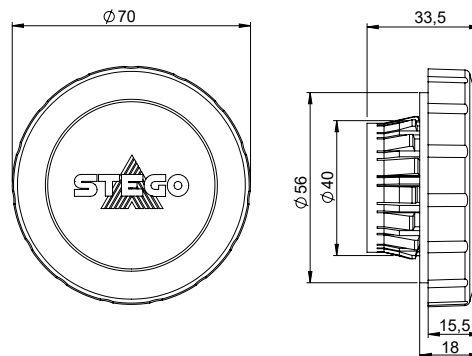

Art. No.	Material	Protection type	Air permeability ¹	Operating/Storage temperature	packing unit	Weight (approx.)	Approvals
28420.0-00	plastic according to UL94 V-0, light grey; weather proof and UV light resistant according to UL746C (f1)	IP66 (EN 60529) / IPX9K (EN 40050-9)	2000 l/h	-35 to +70 °C (-31 to +158 °F)	1 piece	45 g	UL E234324 EAC

¹ at a pressure difference of min. 70 mbar