

## Technisches Datenblatt

Artnr.	GEL12-10B-4
Japan-Code	CT10B-4, CTZ10-S
Nennspannung	12V
Nennkapazität	8,5 AH (c20)
Kälteprüfstrom -18°C (EN)	200 A (EN)
Elektrolyt	verdünnte Schwefelsäure   diluted sulfuric acid
Elektrolytdichte	1,28 +/- 0,01 kg/l (25°)
Abmessungen (LxBxH)	150 x 87 x 94 mm
Schaltung	1

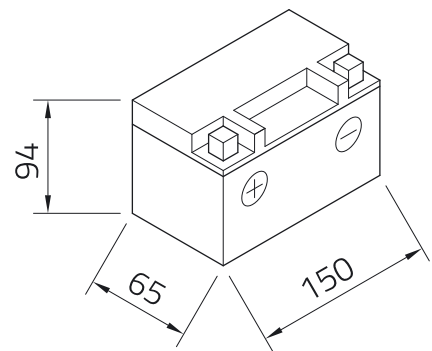
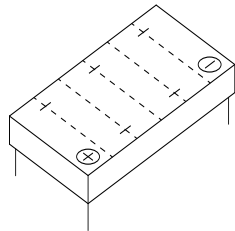

Technologie	Verschlossene GEL-Batterie   Elektrolyt gelartig gebunden   gefüllt und geladen   absolut wartungsfrei
-------------	--

Polausführung	J
---------------	---

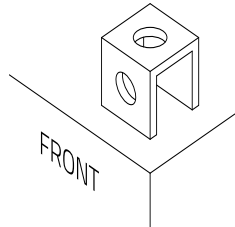

Bodenleiste	-
-------------	---