

Figure 1

1. INTRODUCTION

This instruction sheet covers the use of Extraction Tool 843473-1 which is recommended for removing crimp, snap-in contacts from AMPMODU MOD I and MOD IV Receptacle Connectors listed in Catalog 1307819. Read these instructions before attempting to extract the contacts.

NOTE

All dimensions are in millimeters [with inches in brackets]. Figures are for reference only and are not drawn to scale.

Reasons for reissue are given in SECTION 5, REVISION SUMMARY.

2. DESCRIPTION

The extraction tip is designed to enter the lance recess in the front of the housing and depress the locking lance of the contact.

NOTE

The connector includes both the housing and the contacts while the housing is the material which forms the encapsulation for the contacts.

The lance recess is the cavity located between the contact and the connector housing. A solid rib (locking ledge) at the rear of the lance recess cavity provides a stop for the extraction tool. The housings are designed to prevent improper insertion of the contacts which are inserted into the rear of the housing.

A lug is located on the side of the MOD I housing which contains the contact locking ledge.

3. EXTRACTION PROCEDURE (Figure 1)

Determine which connector contains the contact to be removed and proceed as follows:

1. Insert the tool straight into the lance recess until it bottoms on the locking ledge.
2. Holding the tool and connector in one hand, grip the wire of the contact with the other hand and pull the contact out of the back of the connector.

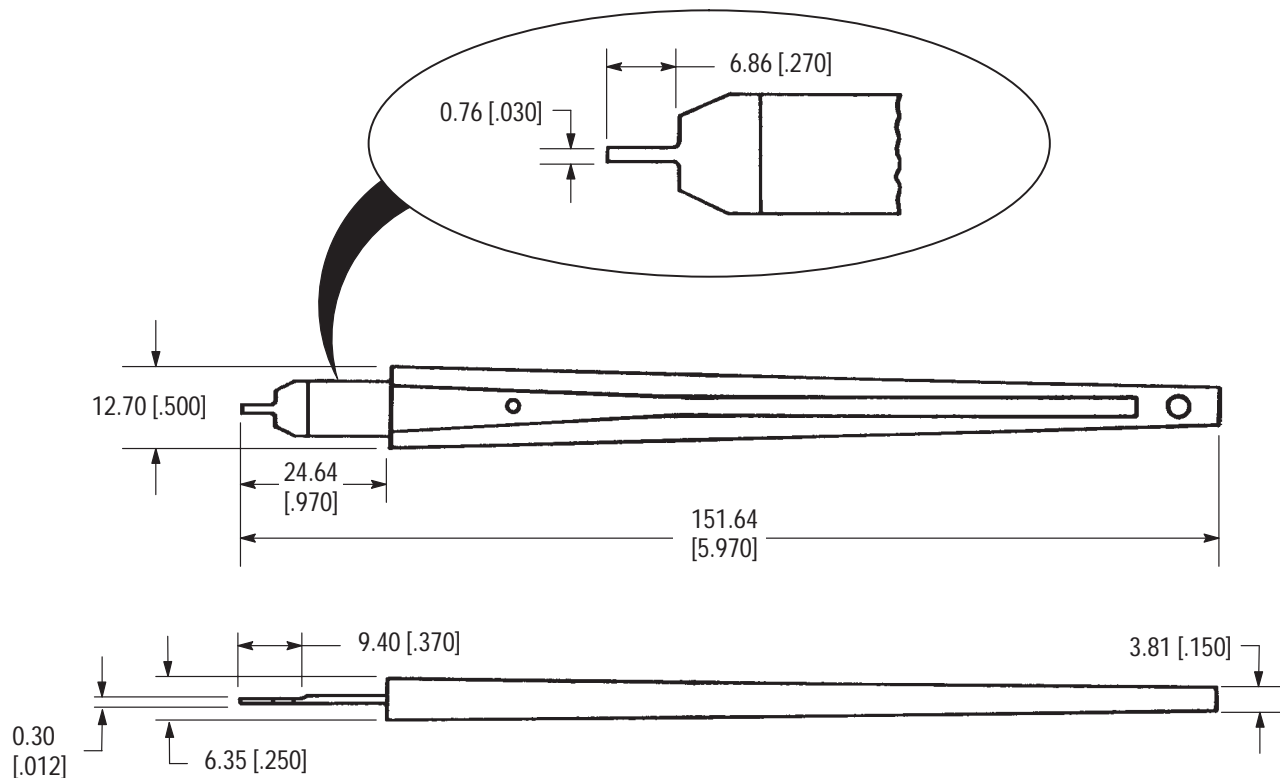

Figure 2

4. TOOL INSPECTION/MAINTENANCE

Extraction Tool 843473-1 should conform to the dimensions listed in Figure 2. Each tool should be inspected upon arrival to be sure it has not been damaged in transit, and at regularly scheduled intervals to be sure it remains functional.

If the tool requires repair, send it with a written description of the problem, to:

CUSTOMER REPAIR (38-35)
TYCO ELECTRONICS CORPORATION
P.O. BOX 3608
HARRISBURG, PA 17105-3608

5. REVISION SUMMARY

Since the previous release of this sheet, the following revisions were made per EC 0990-1206-03:

- Updated document to corporate requirements
- Changed catalog number in Section 1, INTRODUCTION
- Changed repair address in Section 4, TOOL INSPECTION/MAINTENANCE