

MDT0570CSS-RGB	320 x 240	RGB Interface	TFT Module
(MCT057C6W320240LML) Specification			
Version: 9		Date: 26/08/2017	
Revision			
	1	13/03/2013	First issue
	2	08/07/2013	Modify the packing diagram
	3	11/07/2014	Update Rev.
	4	16/03/2015	Correct Contour Drawing
	5	28/04/2015	Modify Reliability
	6	21/01/2016	Modify Static electricity test
	7	11/08/2016	Modify Vibration test
	8	17/11/2016	Modify Summary
	9	24/08/2017	Remove Package Specification

Display Features			
Display Size	5.7"		
Resolution	320 x 240		
Orientation	Landscape		
Appearance	RGB		
Logic Voltage	3.3V		
Interface	RGB		
Brightness	500 cd/m ²		
Touchscreen	---		
Module Size	149.00 x 109.00 x 8.30mm		
Operating Temperature	-20°C ~ +70°C		
Pinout	50 way FFC		Box Quantity
Pitch	0.5mm		Weight / Display

Display Accessories	
Part Number	Description
MCIB-1	50 way FFC to 34 way IDC TFT interface board compatible with VBWV8 microcontroller board.

Optional Variants	
Appearances	Voltage



Summary

TFT 5.7" is a TN transmissive type color active matrix TFT liquid crystal display that use amorphous silicon TFT as switching devices. This module is a composed of a TFT_LCD module, It is usually designed for industrial application and this module follows RoHs,

General Specifications

- Dot Matrix: 320 x RGB x 240(TFT)
- Module dimension: 149.0(W) x 109.0(H) x 8.3(D) mm
- Active area: 115.20 x 86.40 mm
- Dot pitch: 0.12 x 0.36 mm
- LCD type: TFT, Normally White, Transmissive
- View Direction: 12 o'clock
- Gray Scale Inversion Direction: 6 o'clock
- Backlight Type: LED, Normally White

*Color tone slight changed by temperature and driving voltage.

design • manufacture • supply



Interface

LCM PIN Definition

Pin	Symbol	Function	Remark
1	IF1	Input data format control	Note1
2	IF2	Input data format control	Note1
3	POL	Polarity Signal connect to VCOM driving circuit.	Note3
4	RESET	Hardware reset	
5	SPENA	Chip select	Note2
6	SPCL	Serial Clock	Note2
7	SPDA	Serial Data	
8	B0	Blue Data bit	
9	B1	Blue Data bit	
10	B2	Blue Data bit	
11	B3	Blue Data bit	
12	B4	Blue Data bit	
13	B5	Blue Data bit	
14	B6	Blue Data bit	
15	B7	Blue Data bit	
16	G0	Green Data bit	
17	G1	Green Data bit	
18	G2	Green Data bit	
19	G3	Green Data bit	
20	G4	Green Data bit	
21	G5	Green Data bit	
22	G6	Green Data bit	
23	G7	Green Data bit	
24	R0	Red Data bit	
25	R1	Red Data bit	
26	R2	Red Data bit	



27	R3	Red Data bit	
28	R4	Red Data bit	
29	R5	Red Data bit	
30	R6	Red Data bit	
31	R7	Red Data bit	
32	Hsync	Horizontal synchronous signal	
33	Vsync	Vertical synchronous signal	
34	Data CLK	Dot data clock	
35	AVDD(analog)	Analog power: 4.5V~5.5V	
36	AVDD(analog)	Analog power: 4.5V~5.5V	
37	VCC(Digital)	Digital power: 3V~3.6V	
38	VCC(Digital)	Digital power: 3V~3.6V	
39	NPC	NTSC/PAL mode Auto detection result H:NTSC/L:PAL	
40	VGL	Gate off power	
41	VGL	Gate off power	
42	UD	Up/down selection	Note 5,6
43	VGH	Gate on power	
44	LRC	Shift direction of device internal shift register control.	Note 5,6
45	GND	System ground pin of the IC. Connect to system ground.	
46	VCOM	VCOM driving input	Note3
47	VCOM	VCOM driving input	
48	ENB	Signal to settle the horizontal display position	Note4
49	GND	System ground pin of the IC. Connect to system ground.	
50	GND	System ground pin of the IC. Connect to system ground.	



Note1: Control the input data format.

IF2,IF1	Input data format
L,L(default)	Serial RGB
L,H	Parallel RGB
H,L	CCIR601
H,H	CCIR656

Note 2: Pin 5 · Pin 6 usually pull high.

Note 3: The polarity of VCOM (Pin 46,47) should be generated from POL (Pin 3).

Note 4: For digital RGB input data format, both SYNC mode and DE+SYNC mode are supported. If ENB signal is fixed low, SYNC mode is used. Otherwise, DE+SYNC mode is used.

Note 5: Selection of scanning mode

Setting of scan control input		Scanning direction
U/D	L/R	
L	H	Up to down, left to right
H	L	Down to up, right to left
L	L	Up to down, right to left
H	H	Down to up, left to right

MIDAS
design • manufacture • supply



Block Diagram

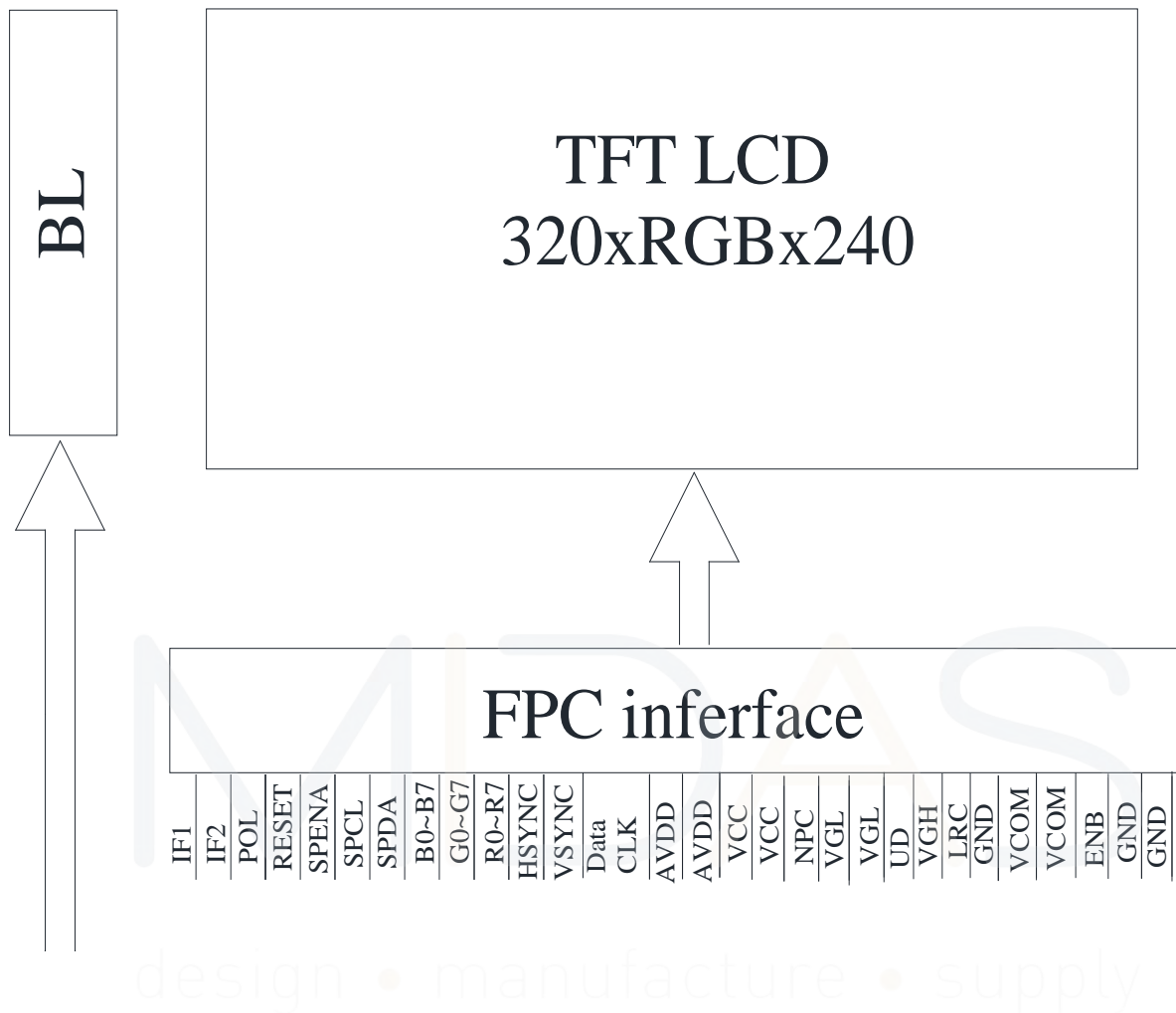

Absolute Maximum Ratings

Item	Symbol	Min	Typ	Max	Unit
Operating Temperature	TOP	-20	—	+70	°C
Storage Temperature	TST	-30	—	+80	°C

Note: Device is subject to be damaged permanently if stresses beyond those absolute maximum ratings listed above

- Temp. $\leq 60^{\circ}\text{C}$, 90% RH MAX. Temp. $> 60^{\circ}\text{C}$, Absolute humidity shall be less than 90% RH at 60°C



Electrical Characteristics

Operating conditions:

Item	Symbol	Condition	Min	Typ	Max	Unit	Remark
Supply Voltage For LCM	VCC	—	3.0	3.3	3.6	V	—
Supply Current For LCM	ICC	—	—	17	25	mA	Note1
Input High Volt.	VIH	—	0.7 VCC	—	VCC	V	—
Input Low Volt.	VIL	—	0	—	0.3 VCC	V	—
LCD Driving Supply Voltage	VGH	—	15	—	—	V	—
	VGL	—	-10	—	—	V	—
	VCOMH	—	2.5	—	5.5	V	—
	VCOML	—	-2.0	—	0	V	—
	AVDD	—	4.5	5.0	5.5	V	—

Note 1 : This value is test for VCC = 3.3V , Ta=25 °C only

LED driving conditions

Parameter	Symbol	Min.	Typ.	Max.	Unit	Remark
LED current	-	-	140	-	mA	-
Power Consumption	-	1260	-	1470	mW	-
LED voltage	VBL+	9.0	-	10.5	V	Note 1
LED Life Time	-	-	50,000	-	Hr	Note 2,3,4

Note 1 : There are 1 Groups LED

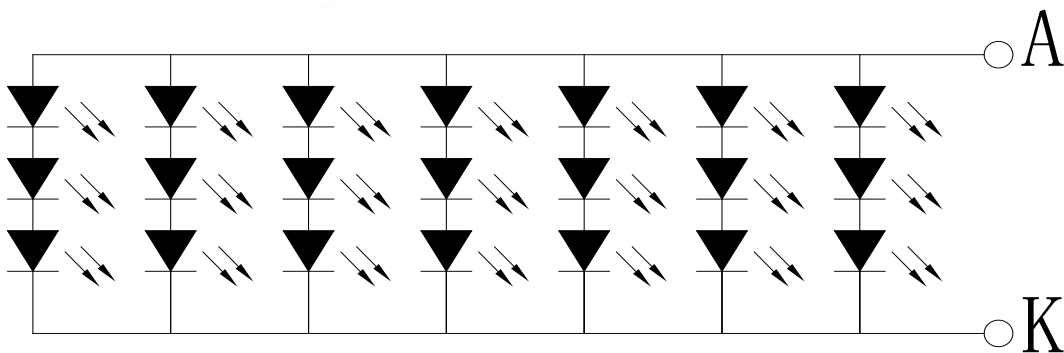

Note 2 : Ta = 25 °C

Note 3 : Brightness to be decreased to 50% of the initial value

Note 4 : The single LED lamp case.



AC CHARACTERISTICS

CCIR601/656 Interface Input signal characteristics

Parameter	Symbol	Min.	Typ.	Max.	Unit
CLK period	Tosc	-	37	-	ns
Data setup time	Tsu	12	-	-	ns
Data hold time	THo	12	-	-	ns

Hardware reset timing

Parameter	Symbol	Min.	Typ	Max	Unit
Reset low pulse width	TRSB	10	-	-	μs

Output signal characteristics

Parameter	Symbol	Min.	Typ.	Max.	Unit	
Rising time	Tr	-	-	10	ns	
Falling time	Tf	-	-	10	ns	
Internal STH setup time	Tsus	12	-	-	ns	
Internal STH hold time	THDS	12	-	-	ns	
Internal data setup time	TSUD	60	-	-	ns	
Internal I data hold time	THDD	40	-	-	ns	
OEH pulse width	TOEH	-	1248	-	ns	
OEV pulse width	TOEV	-	4992	-	ns	
CKV pulse width	TCKV	-	3744	-	ns	
Hsync-DEH time	T1	-	4368	-	ns	
Hsync-CKV time	T2	-	2496	-	ns	
Hsync-OEV time	T3	-	624	-	ns	
Vsync-setup time	TSUV	-	1872	-	ns	
Vsync-pulse time	TSTV	-	1	-	TH	
Vsync-STV time	NTSC	TVS1	-	19	-	TH
	PAL	TVS1	-	27	-	TH
OEH-STV time	THE	-	2	-	TH	
Output settling time	TOES	-	12	20	μs	



24-bits parallel RGB Interface AC Timing Characteristics

Signal	Item	Symbol	Min.	Typ.	Max.	Unit	
Dclk	Frequency	Dclk	-	6.4	-	MHZ	
	High time	Tch	-	78	-	ns	
	Low time	Tcl	-	78	-	ns	
Hsync	Period	TH	-	408	-	DCLK	
	Pulse Width	Thp	-	30	-	DCLK	
	Back-Porch	Thb	-	38	-	DCLK	
	Display Period	Thd	-	320	-	DCLK	
	Front-Porch	Thf	-	20	-	DCLK	
Vsync	Period	NTSC	TV	-	262.5	-	DCLK
		PAL			312.5		
	Pulse Width		Tvp	1	3	5	TH
	Back-Porch	NTSC	Tvb	-	15	-	TH
		PAL			23		
	Display Period		Tvd	-	240	-	TH
	Front-Porch	NTSC	Tvf	-	4.5	-	TH
		PAL			46.5		

AC Timing Diagrams

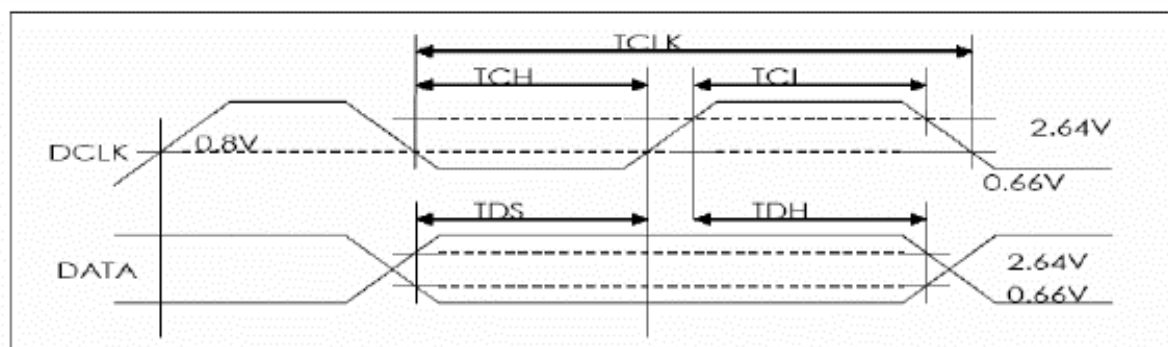
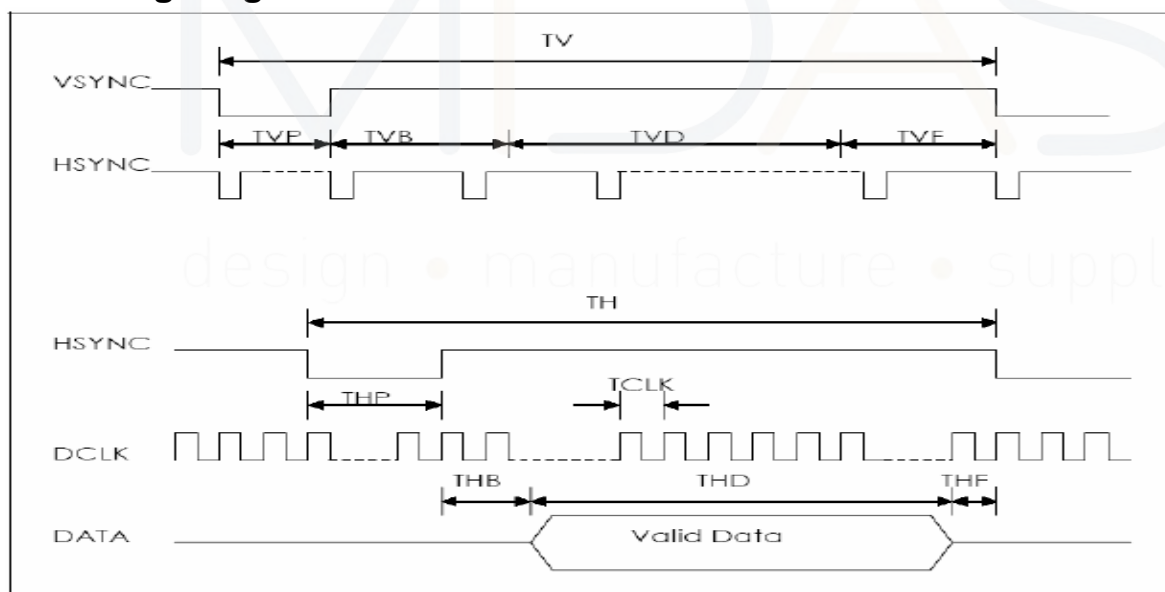

Waveform

Timing Controller Timing Chart Clock and Data waveform

- CCIR601(HS_POL="L" in Register R2)

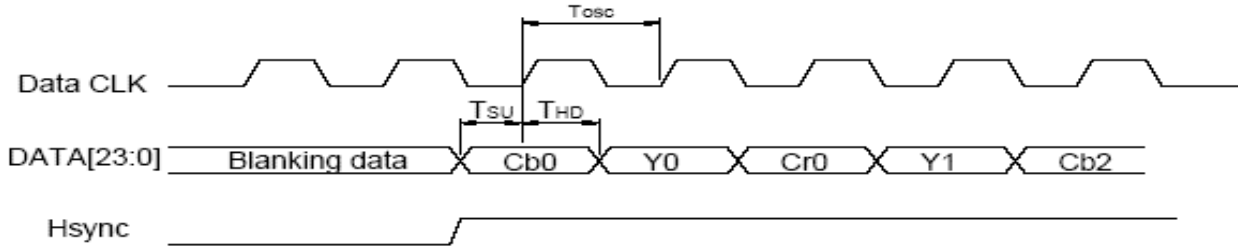

- CCIR656

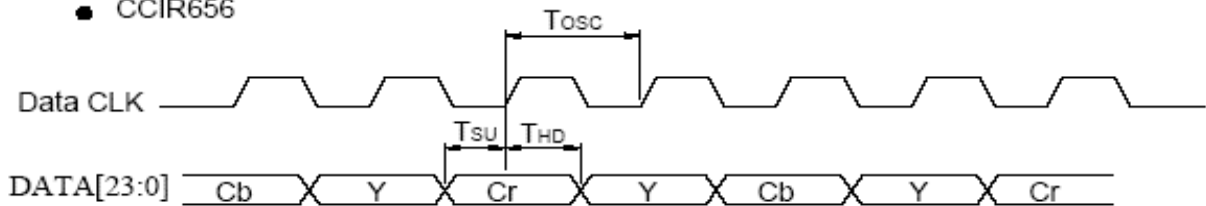

Digital / Analog RGB timing waveform Hsync and Vsync timing

- Odd field

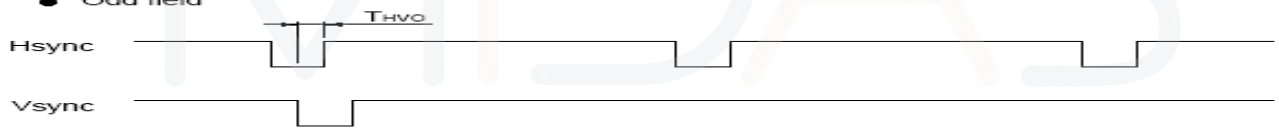

- Even field



Hsync and horizontal control timing waveform

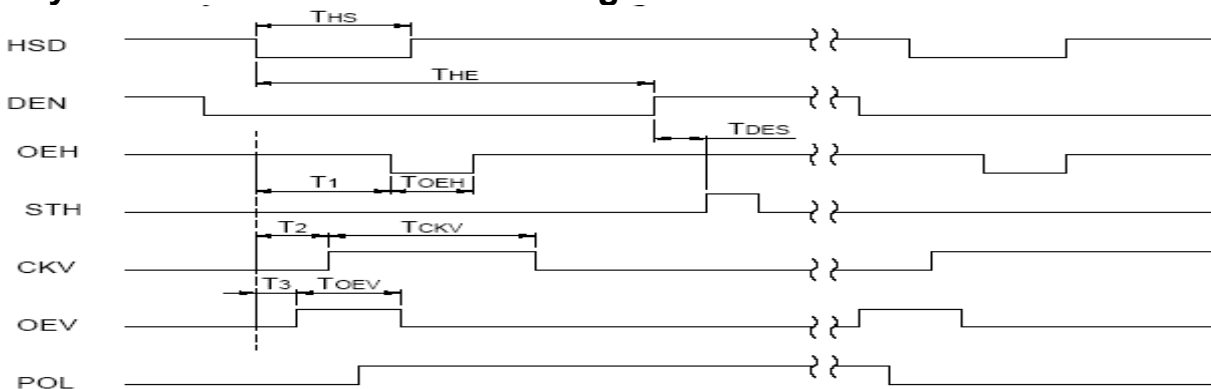

Hsync and vertical shift clock timing waveform

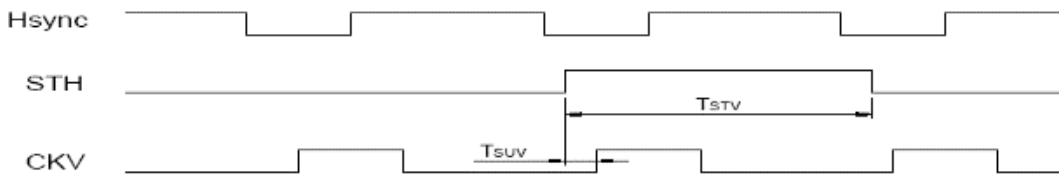

Hsync and vertical shift clock timing waveform

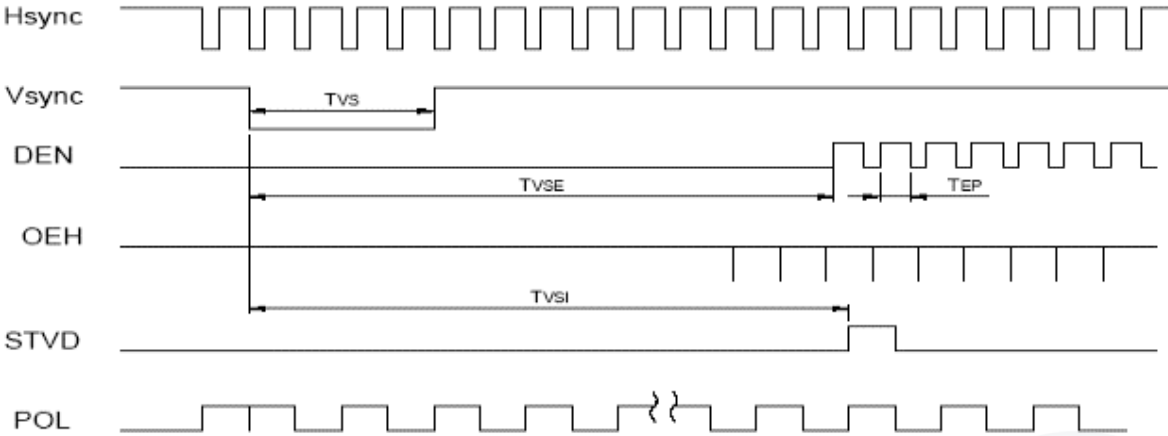

CCIR601 timing waveform (VS_POL="H" , HS_POL="L" in Register R2)

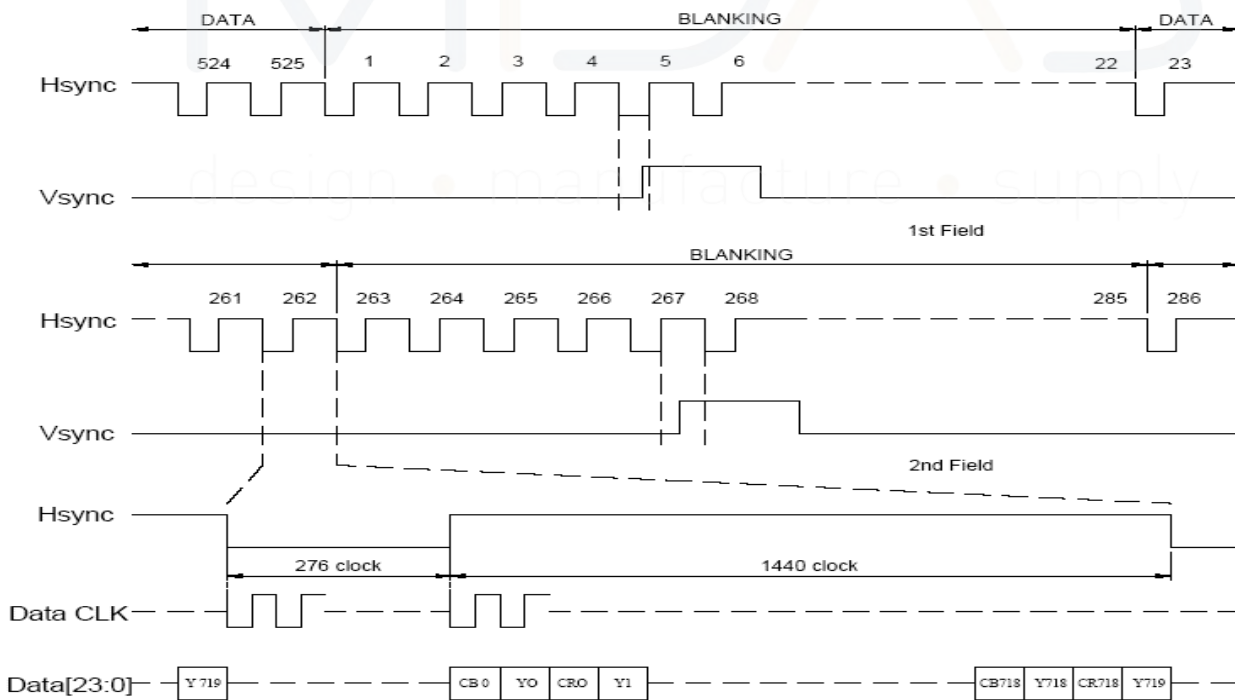

ITU-BT.601 NTSC Input Timing



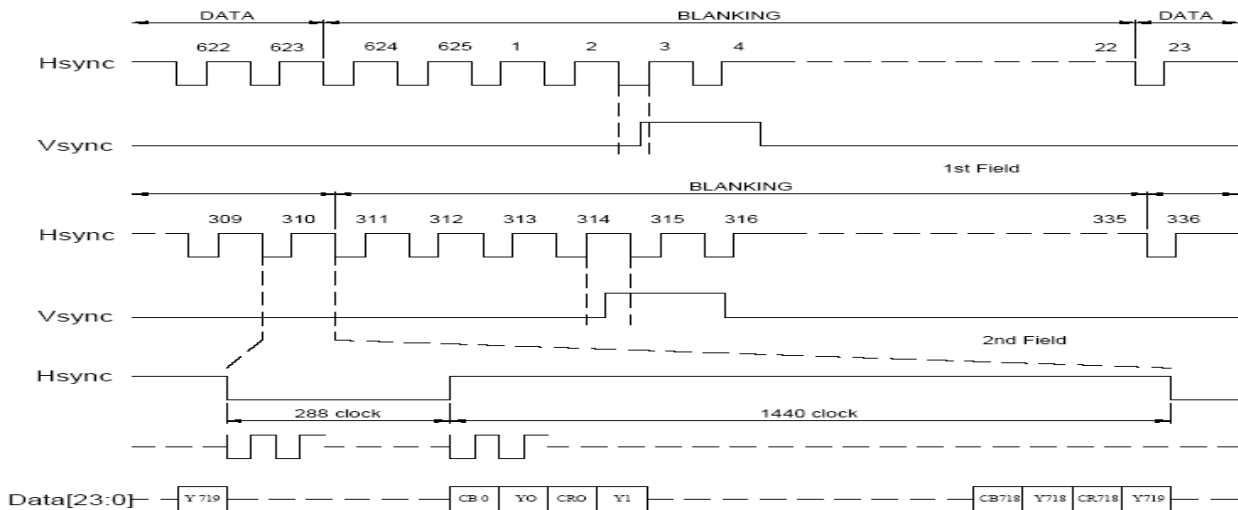

ITU-BT.601 PAL Input Timing

Source Driver Timing Chart Clock and Start Pulse timing waveform

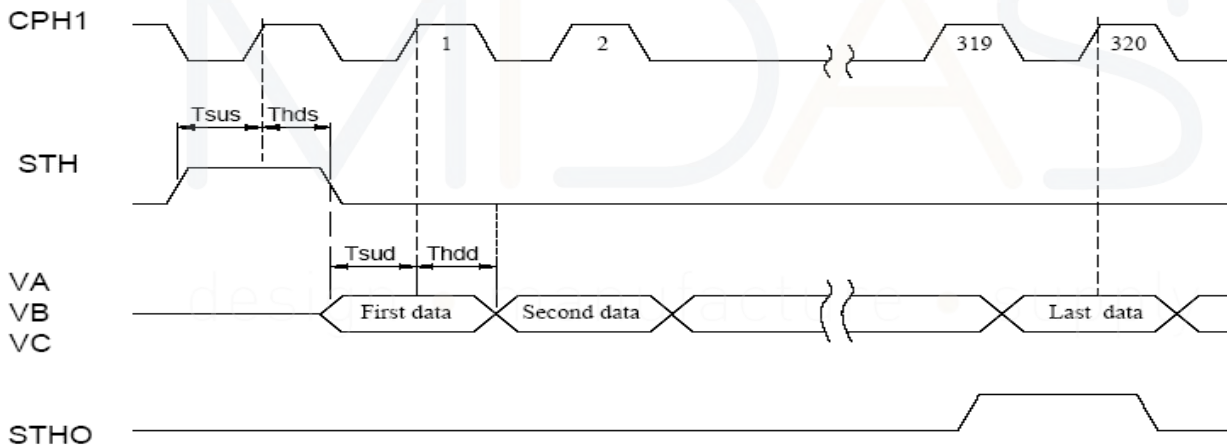

OEH and Data Output timing waveform

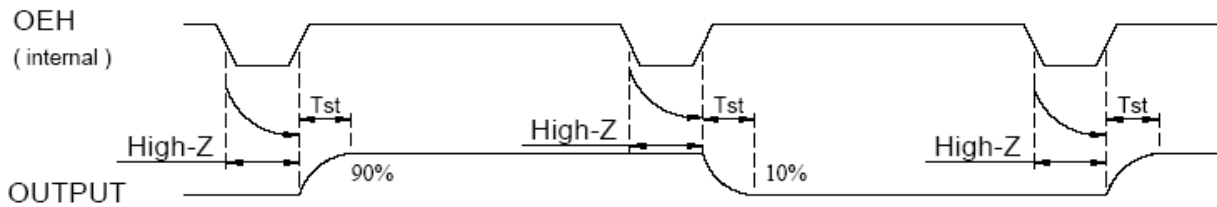

Analog video signal characteristics

PARAMETER	Symbol	Min.	Typ.	Max.	Unit
Video signal amplitude (VA, VB, VC)	V_{IAC}	-	3.81	-	V
	V_{IDC}	-	2.385	-	V

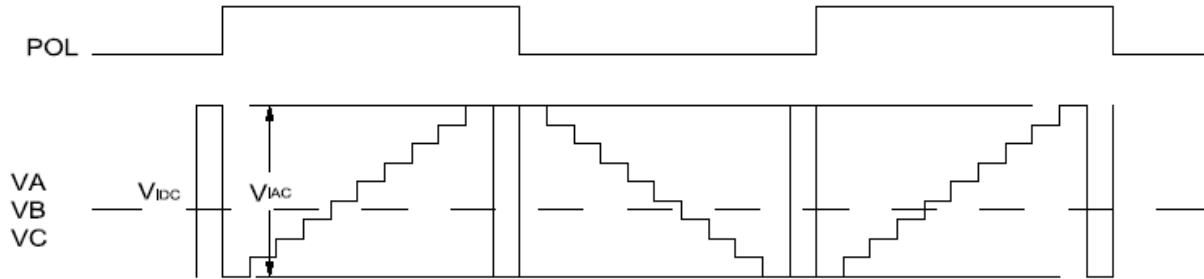
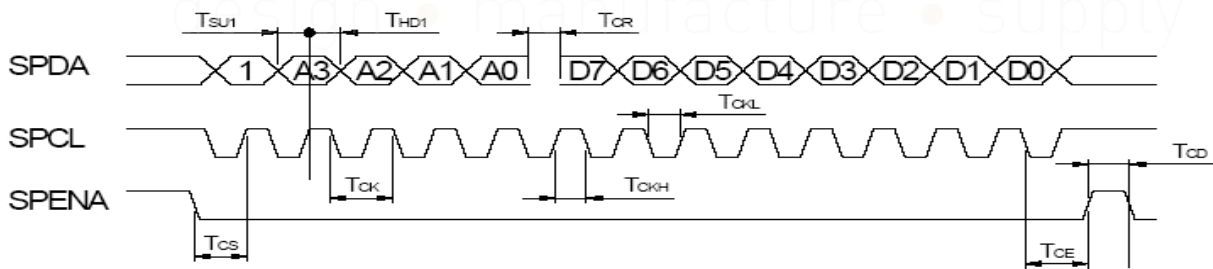

Fig. 4-(a) Horizontal timing

SPI timing characteristics

Parameter	Symbol	Min.	Typ.	Max.	Unit
SPCL period	T_{CK}	60	-	-	ns
SPCL high width	T_{CKH}	30	-	-	ns
SPCL low width	T_{CKL}	30	-	-	ns
Data setup time	T_{SU1}	12	-	-	ns
Data hold time	T_{HD1}	12	-	-	ns
SPENA to SPCK setup time	T_{CS}	20	-	-	ns
SPENA to SPDA hold time	T_{CE}	20	-	-	ns
SPENA high pulse width	T_{CD}	50	-	-	ns
SPDA output latency	T_{CR}	-	1/2	-	T_{CK}

● SPI "read" timing



● SPI "write" timing

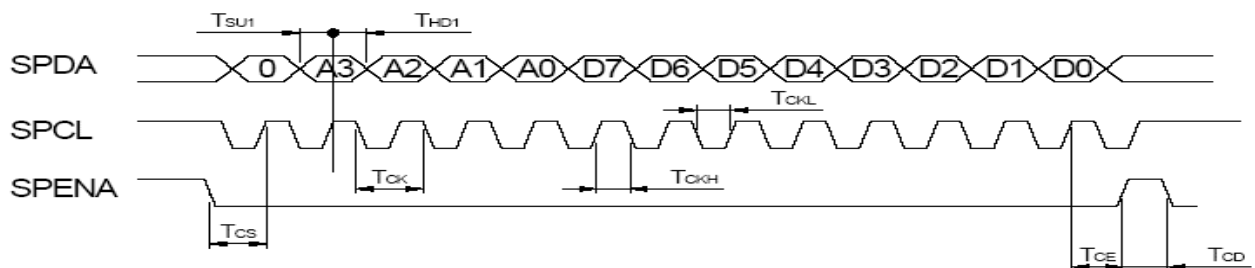

Gate Driver Timing Chart

Parameter	Symbol	Condition	Spec		Unit
			Min.	Max.	
Operation frequency	tCPV	-	5	-	us
CPV pulse width	tCPVH,tCPVL	50%duty cycle	2.5	-	
OE pulse width	twOE	-	1	-	us
Data setup time	tsu	-	0.4	-	
Data hold time	thd	-	0.7	-	
Output delay time	tpd1	CL=300pF	-	1	
Output delay time	tpd2	CL=300pF	-	0.8	
Output delay time	tpd3	CL=300pF	-	0.8	
Output delay time	tpd4	CL=300pF	-	10	

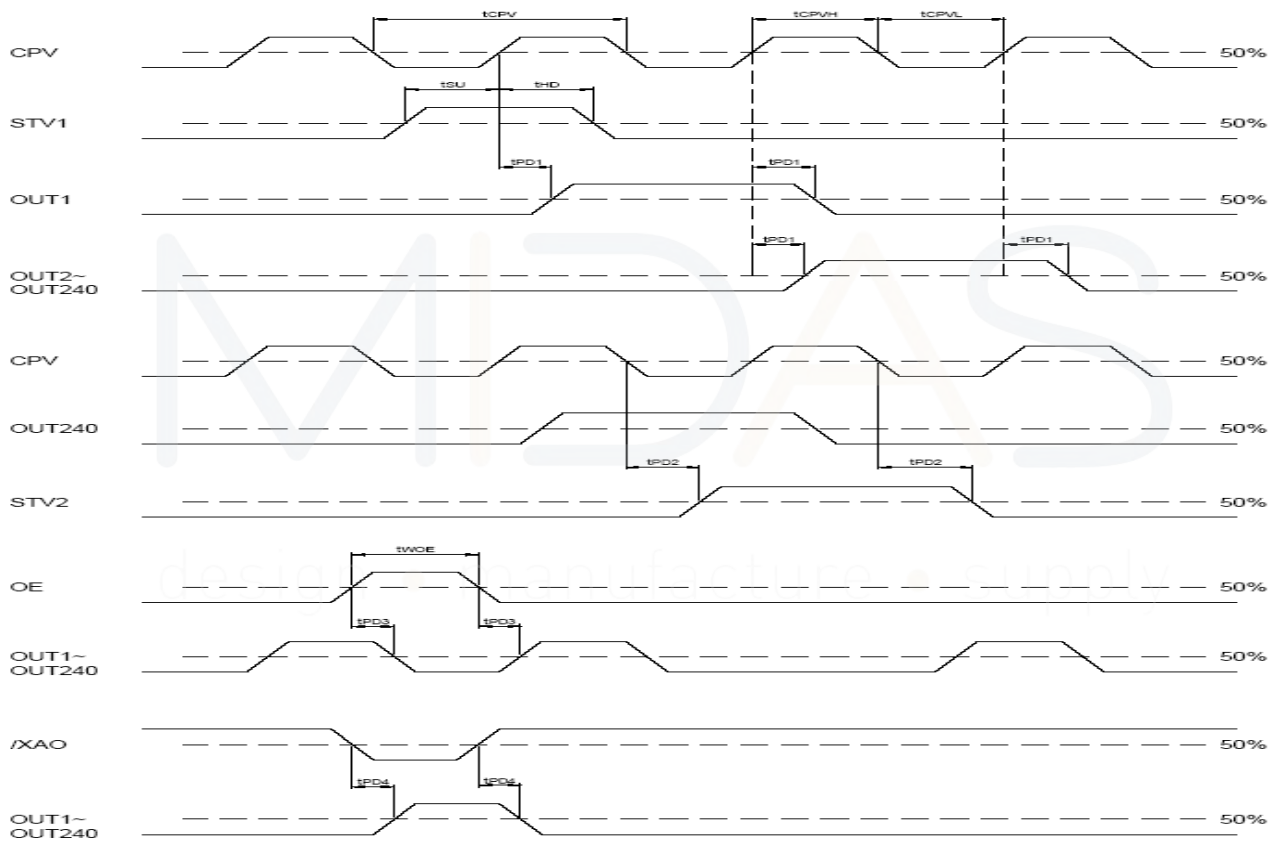

Optical Characteristics

Item	Symbol	Condition.	Min	Typ.	Max.	Unit	Remark
Response time	Tr	$\theta=0^\circ \cdot \phi=0^\circ$	-	15	30	.ms	Note 3,5
	Tf		-	35	50	.ms	
Contrast ratio	CR	At optimized viewing angle	150	200	-	-	Note 4,5
Color Chromaticity	White	Wx	$\theta=0^\circ \cdot \phi=0$	0.27	0.32	0.37	Note 2,6,7
		Wy		0.30	0.35	0.40	
Viewing angle	Hor.	Θ_R	$CR \geq 10$	60	70	Deg.	Note 1
		Θ_L		60	70		
	Ver.	Φ_T		40	50		
		Φ_B		60	70		
Brightness	-	-	400	500		cd/m ²	Center of display

Ta=25±2°C

Note 1: Definition of viewing angle range

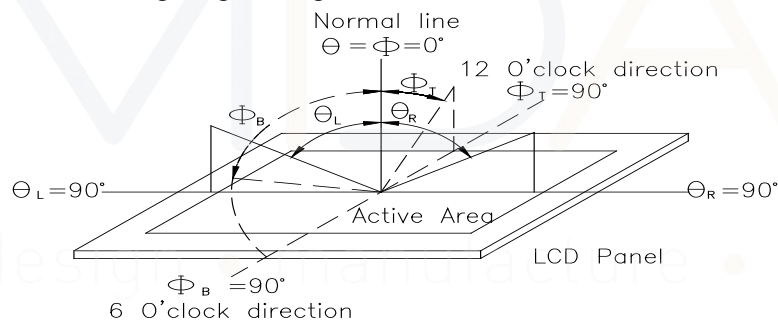

Fig. 11.1. Definition of viewing angle

Note 2: Test equipment setup:

After stabilizing and leaving the panel alone at a driven temperature for 10 minutes, the measurement should be executed. Measurement should be executed in a stable, windless, and dark room. Optical specifications are measured by Topcon BM-7 or BM-5 luminance meter 1.0° field of view at a distance of 50cm and normal direction.

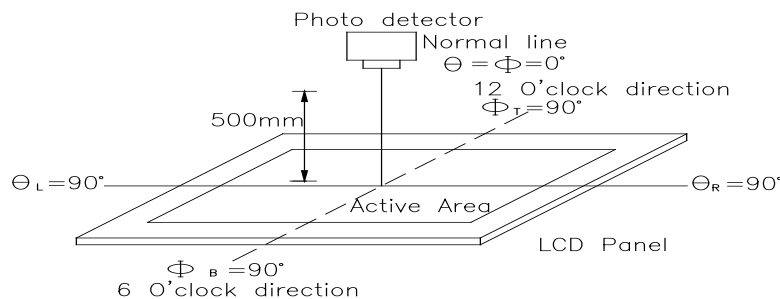
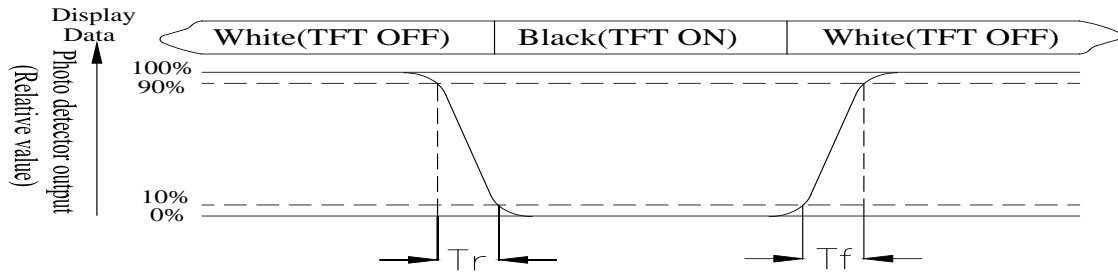

Fig. 11.2. Optical measurement system setup



Note 3: Definition of Response time:

The response time is defined as the LCD optical switching time interval between "White" state and "Black" state. Rise time, T_r , is the time between photo detector output intensity changed from 90% to 10%. And fall time, T_f , is the time between photo detector output intensity changed from 10% to 90%



Note 4: Definition of contrast ratio:

The contrast ratio is defined as the following expression.

$$\text{Contrast ratio (CR)} = \frac{\text{Luminance measured when LCD on the "White" state}}{\text{Luminance measured when LCD on the "Black" state}}$$

Note 5: White $V_i = V_{i50} \pm 1.5V$

Black $V_i = V_{i50} \pm 2.0V$

"±" means that the analog input signal swings in phase with VCOM signal.

"±" means that the analog input signal swings out of phase with VCOM signal.

The 100% transmission is defined as the transmission of LCD panel when all the input terminals of module are electrically opened.

Note 6: Definition of color chromaticity (CIE 1931)

Color coordinates measured at the center point of LCD

Note 7: Measured at the center area of the panel when all the input terminals of LCD panel are electrically opened.

design • manufacture • supply



Reliability

Content of Reliability Test (Wide temperature, -20°C~70°C)

Environmental Test			
Test Item	Content of Test	Test Condition	Note
High Temperature storage	Endurance test applying the high storage temperature for a long time.	80°C 200hrs	2
Low Temperature storage	Endurance test applying the low storage temperature for a long time.	-30°C 200hrs	1,2
High Temperature Operation	Endurance test applying the electric stress (Voltage & Current) and the thermal stress to the element for a long time.	70°C 200hrs	—
Low Temperature Operation	Endurance test applying the electric stress under low temperature for a long time.	-20°C 200hrs	1
High Temperature/ Humidity Operation	The module should be allowed to stand at 60°C,90%RH max	60°C,90%RH 96hrs	1,2
Thermal shock resistance	The sample should be allowed stand the following 10 cycles of operation <div style="text-align: center;"> <p style="margin: 0;">-20°C 25°C 70°C</p> <p style="margin: 0;">30min 5min 30min</p> <p style="margin: 0;">1 cycle</p> </div>	-20°C/70°C 10 cycles	—
Vibration test	Endurance test applying the vibration during transportation and using.	Total fixed amplitude : 3 1.5mm Vibration Frequency : 10~55Hz One cycle 60 seconds to 3 directions of X,Y,Z for Each 15 minutes	3
Static electricity test	Endurance test applying the electric stress to the terminal.	VS=±600V(contact) ,±800v(air), RS=330Ω CS=150pF 10 times	—

Note1: No dew condensation to be observed.

Note2: The function test shall be conducted after 4 hours storage at the normal Temperature and humidity after remove from the test chamber.

Note3: The packing have to including into the vibration testing.