

› GNR3 Series

Classic Solid State Relays

DIN Rail Mount - Three Phase

- › 25 Amps
- › Zero Cross & Special Zero Cross (for resistive, inductive and capacitive loads)
- › AC and DC control
- › 3 legs control
- › Output overvoltage protection
- › cRUus, CE and UKCA Recognized



GNR3
(Marking label 26532004 sold separately)

Product Selection - Zero Cross (Resistive Loads)	
Rated Load Current	25A
Output Voltage	24-660 V~
Control Voltage	
4-32 V=	GNR25DCZH

Product Selection - Special Zero Cross (Resistive, Inductive and Capacitive Loads)	
Rated Load Current	25A
Output Voltage	24-660 V~
Control Voltage	
24-255 V~	GNR25ACZH

Part number system
GNR3 Din-Rail

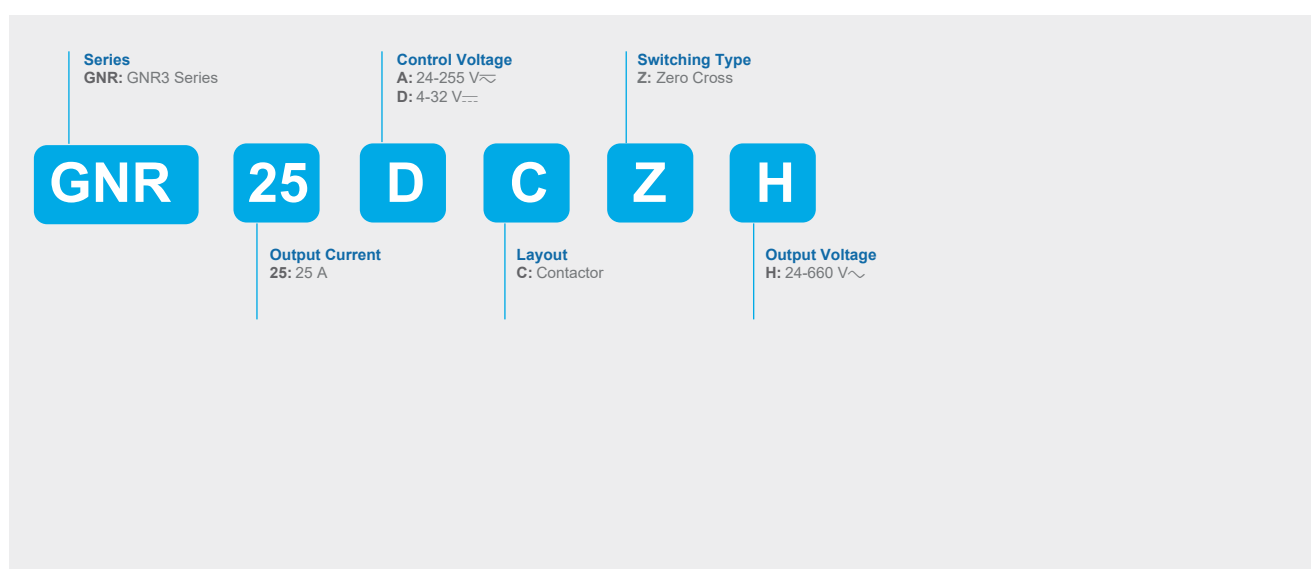

Do you need an adapted or customized solution? Contact us on www.crouzet.com

Description:

Crouzet Solid State Relays are designed to be used in almost any application, offering very long life expectancy and are easy to install, easy to use, robust and multipurpose.

For more information about Crouzet's Solid State relays, please visit www.crouzet.com.

Accessories		
Type	Description	Part-Number
ID Tag	Marking label 16 x 8 x 1 mm	26532004

Output Characteristics ⁽¹⁾	
Description	25A
Operating Voltage (47-440 Hz) [Vrms]	24-660 V \sim
Load Current, General Use UL508 /AC51 @ 40 °C [Arms]	3 x 25 @ 40 °C
Load Current, AC-53a @ 480 V \sim [Arms] ⁽²⁾	5 A ⁽²⁾
Minimum Load Current [mArms]	5
Transient Overvoltage [Vpk]	1200 (1100)
Maximum Surge Current (50/60 Hz (typ.@ 50 °C, 1 Cycle) [Apk]	530/_ (min) 580 (typ)
Maximum I ² t for Fusing (50/60 Hz 1/2 cycle) [A ² sec]	1404 (min) 1680 (typ)
1 second surge current (Apeak. Ta=25 °C) 50/60 Hz	165
Minimum Off-State dv/dt @ Maximum Rated Voltage [V/ μ sec]	500
Maximum Off-State Leakage Current @ Rated Voltage [mArms]	1
Maximum On-State Voltage Drop @ Rated Current [Vpk]	1.04
Thermal Resistance Junction to Case (Rjc) [°C/W]	0.55
Minimum Power Factor (at Maximum load)	0.8

Input Characteristics ⁽¹⁾		
Description	4-32 V $\overline{\text{---}}$	24-255 V \sim
Control Voltage Range	4-32 V $\overline{\text{---}}$	24-255 V \sim
Minimum Turn-On Voltage	4 V $\overline{\text{---}}$	24 V \sim
Must Turn-Off Voltage	2 V $\overline{\text{---}}$	2 V \sim
Maximum Reverse Voltage	-32 V $\overline{\text{---}}$	N/A
Minimum Input Current [mA]	20 mA	5 mA (AC) 4 mA (DC)
Maximum Input Current [mA]	25 mA	7 mArms
Nominal Input Impedance [Ohms]	Current Regulated	
Maximum Turn-On Time	1/2 Cycle	25 ms
Maximum Turn-Off Time	1/2 Cycle	50 ms

General Characteristics	
Description	25A
Dielectric Strength 50/60 Hz (Vrms)	4000 (Input-Output-Case)
Minimum Insulation Resistance (@ 500 V $\overline{\text{---}}$)	10 ⁹ Ω
Maximum Capacitance, Input/Output	0.8 pF
Ambient Operating Temperature Range	-40 °C to 80 °C
Ambient Storage Temperature Range	-40 °C to 100 °C
Housing Material	UL94 V-0
Basplate Material	Aluminium
Terminals	Screw Type
Control wiring Screw Torque (in-lb/Nm)	11-18/ 1.2-2
Power wiring screws Torque (in-lb/Nm)	18-26/ 2-3
Humidity	85 % non-condensing
Input Status Indicator	LED Green
Weight (g)	740
MTBF (Mean Time Before Failure) @ 40 °C (years)	33

General Notes

- (1) All parameters at 25 °C unless otherwise
- (2) Valid only for part number GNR25ACZH

Diagrams

Wiring

GNR3 Series

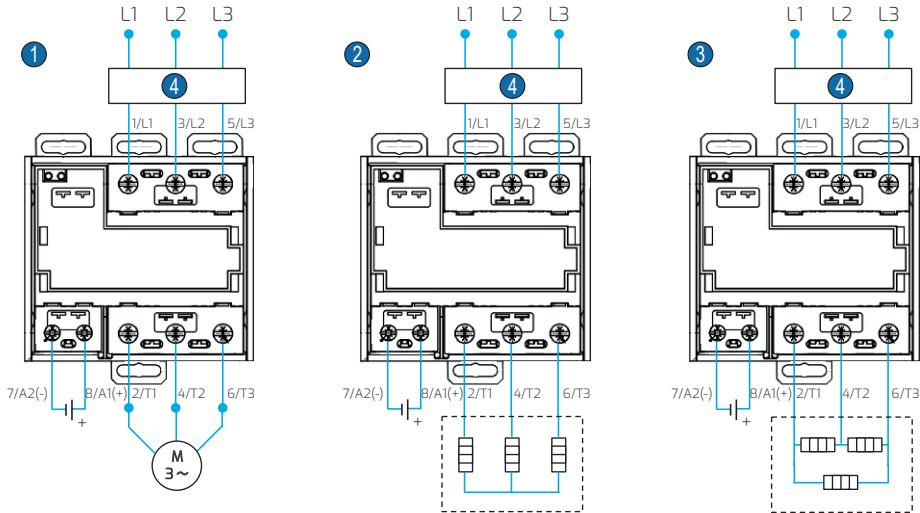

- 1 Wiring to control a 3-phase motor
- 2 Wiring to control heaters connected in star
- 3 Wiring to control heaters connected in delta
- 4 Protection Equipment

Recommended Wire Size

TERMINALS	WIRE SIZE		Terminal Screw Torque (N.m)
	SOLID	STRANDED	
Input	18..14 AWG (0.75..2.5 mm ²) 2 x 18..14 AWG (0.75..2.5 mm ²)	18..14 AWG (0.75..2.5 mm ²) 2 x 18..14 AWG (0.75..2.5 mm ²)	1.2 - 2
Output	8..16 AWG (1.5..10 mm ²) 2 x 8..16 AWG (1.5..10 mm ²)	10..16 AWG (1.5..6 mm ²) 2 x 10..16 AWG (1.5..6 mm ²)	2 - 3

Diagrams

Equivalent Circuit Block

GNR3 Series 4-32 V \sim control Thyristors - 24-660 V \sim - Zero Cross - GNR25DCZH

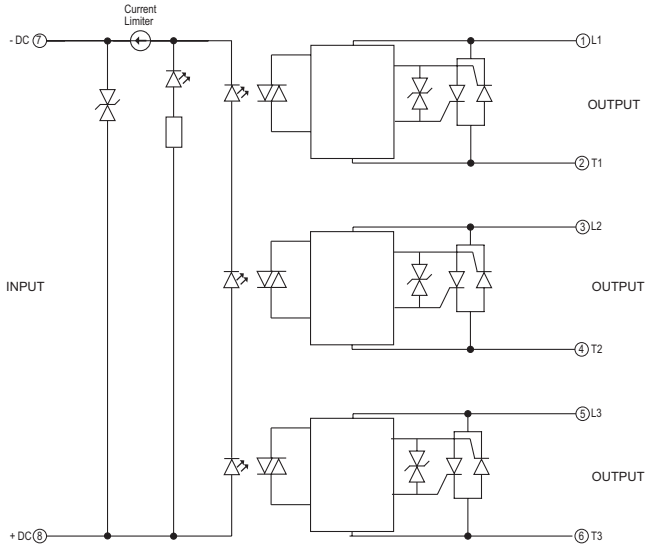

Input current vs Input Voltage
Standard Regulated DC inputs

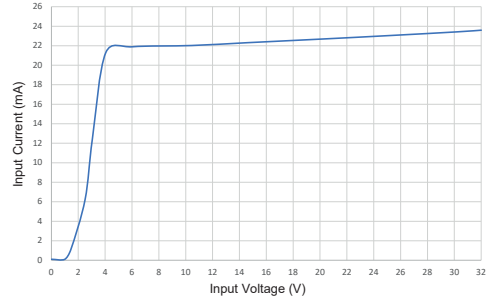

GNR3 Series 24-255 V \sim control Thyristors - 24-660 V \sim - Special Zero Cross - GNR25ACZH

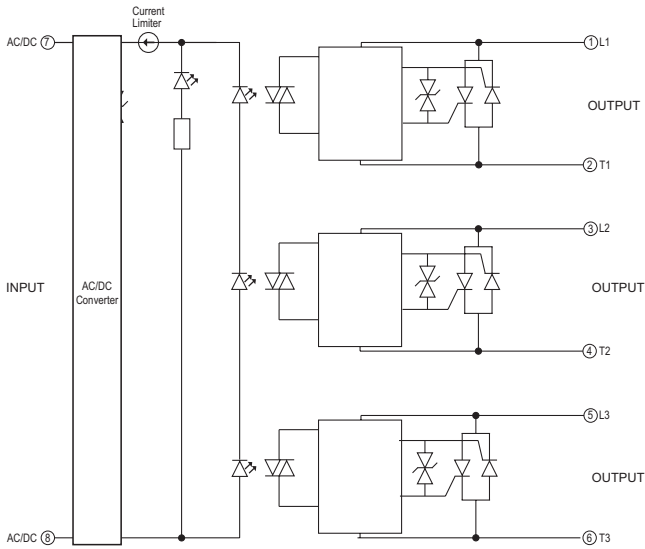

Input current vs Input Voltage
Standard Regulated DC inputs

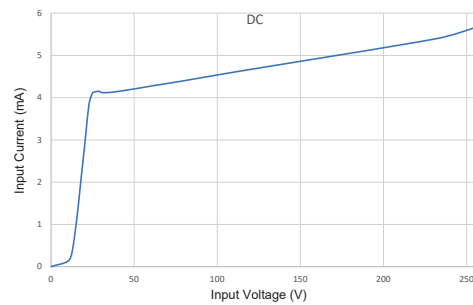
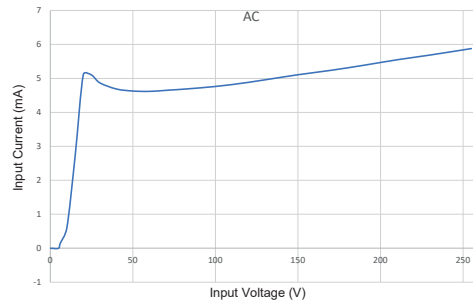

Diagrams

Dimensions (mm)

GNR3 Series

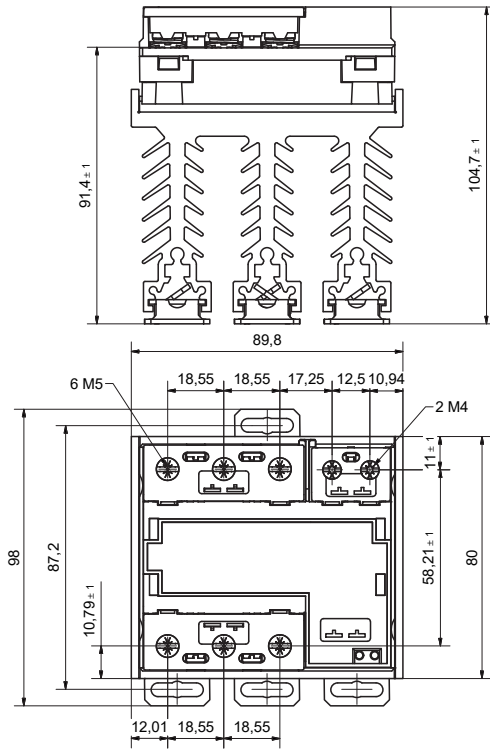

Curves

Surge Current Information

GNR3 - 25 A

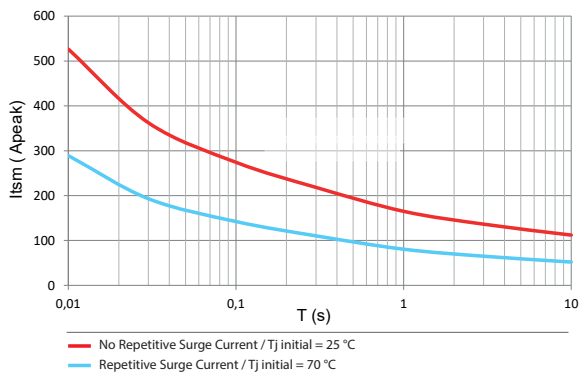

Curves

Thermal Derating Curves

GNR3 - 25 A

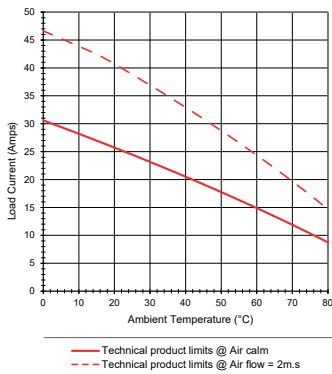

Accessories

Others

ID Tag - 26532004



Standards & Electromagnetic Compatibility Specification

IEC 60068-2-6 Vibration 35 mm / Amplitude 10-55 Hz
IEC 60068-2-27 Shock resistance 15 G / 11 ms
IEC 61000-4-2: Electrostatic Discharge immunity test 8kV air discharge Criterion A Level 3
IEC 1000-4-3: Radiated Electromagnetic Noise - Level 3
IEC 61000-4-4: Electrical fast transient/burst immunity test 1kV Line to Line Criterion B Level 3
IEC 61000-4-5: Surge immunity test 1kV Line to Line Criterion B Level 3
IEC 1000-4-6: Conducted Electromagnetic Noise - Level 3

Standards



Warning:

The product information contained in this catalogue is given purely as information and does not constitute a representation, warranty or any form of contractual commitment. Crouzet and its subsidiaries reserve the right to modify their products without notice. It is imperative that we should be consulted over any particular use or application of our products and it is the responsibility of the buyer to establish, particularly through all the appropriate tests, that the product is suitable for the use or application. Under no circumstances will our warranty apply, nor shall we be held responsible for any application (such as any modification, addition, deletion, use in conjunction with other electrical or electronic components, circuits or assemblies, or any other unsuitable material or substance) which has not been expressly agreed by us prior to the sale of our products.