

Silicon NPN Power Transistors

TIP31/31A/31B/31C

DESCRIPTION

- With TO-220C package
- Complement to type TIP32/32A/32B/32C

APPLICATIONS

- Medium power linear switching applications

PINNING

PIN	DESCRIPTION
1	Base
2	Collector;connected to mounting base
3	Emitter

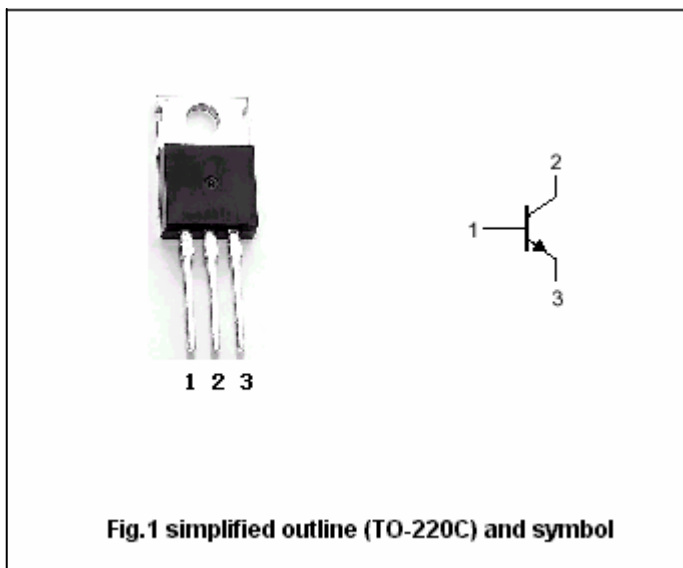

Fig.1 simplified outline (TO-220C) and symbol

Absolute maximum ratings(Ta=25)

SYMBOL	PARAMETER	CONDITIONS	VALUE	UNIT
V _{CBO}	Collector-base voltage	TIP31	40	V
		TIP31A	60	
		TIP31B	80	
		TIP31C	100	
V _{CEO}	Collector-emitter voltage	TIP31	40	V
		TIP31A	60	
		TIP31B	80	
		TIP31C	100	
V _{EBO}	Emitter-base voltage	Open collector	5	V
I _C	Collector current (DC)		3	A
I _{CM}	Collector current-Pulse		5	A
I _B	Base current		1	A
P _C	Collector power dissipation	T _C =25	40	w
		T _a =25	2	
T _j	Junction temperature		150	
T _{stg}	Storage temperature		-65~150	

Silicon NPN Power Transistors

TIP31/31A/31B/31C

CHARACTERISTICS

T_j=25 unless otherwise specified

SYMBOL	PARAMETER	CONDITIONS	MIN	TYP.	MAX	UNIT	
V _{CEO(SUS)}	Collector-emitter sustaining voltage	TIP31	40			V	
		TIP31A	60				
		TIP31B	80				
		TIP31C	100				
V _{CEsat}	Collector-emitter saturation voltage	I _C =3A I _B =0.375A			1.2	V	
V _{BE}	Base-emitter on voltage	I _C =3A ; V _{CE} =4V			1.8	V	
I _{CES}	Collector cut-off current	TIP31	V _{CE} =40V; V _{EB} =0			0.2	mA
		TIP31A	V _{CE} =60V; V _{EB} =0				
		TIP31B	V _{CE} =80V; V _{EB} =0				
		TIP31C	V _{CE} =100V; V _{EB} =0				
I _{CEO}	Collector cut-off current	TIP31/31A	V _{CE} =30V; I _B =0			0.3	mA
		TIP31B/31C	V _{CE} =60V; I _B =0				
I _{EBO}	Emitter cut-off current	V _{EB} =5V; I _C =0			1.0	mA	
h _{FE-1}	DC current gain	I _C =1A ; V _{CE} =4V	25				
h _{FE-2}	DC current gain	I _C =3A ; V _{CE} =4V	10		50		
f _T	Transiton frequency	I _C =0.5A ; V _{CE} =10V	3			MHz	

Silicon NPN Power Transistors

TIP31/31A/31B/31C

PACKAGE OUTLINE

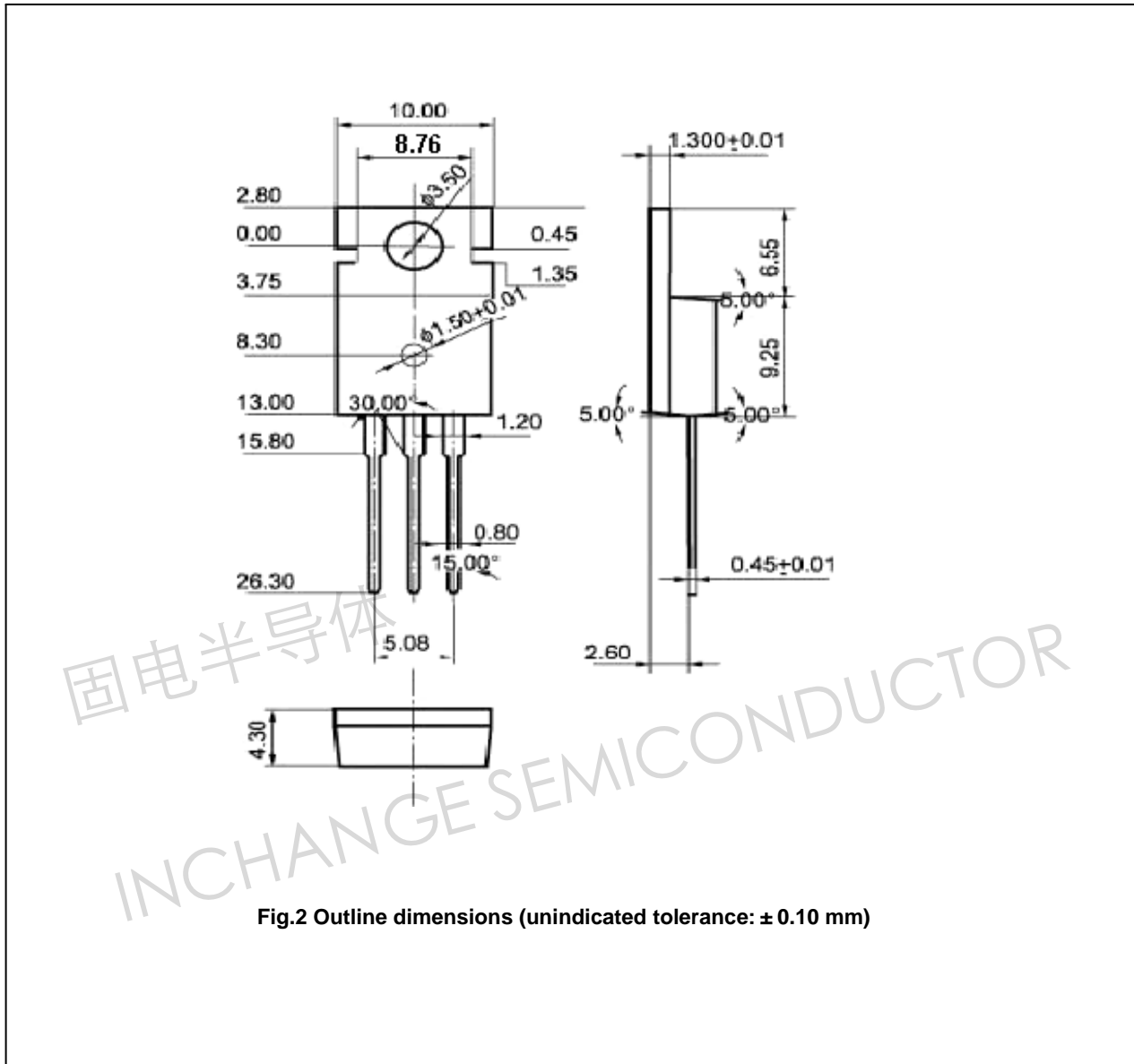

Fig.2 Outline dimensions (unindicated tolerance: ± 0.10 mm)

Silicon NPN Power Transistors

TIP31/31A/31B/31C

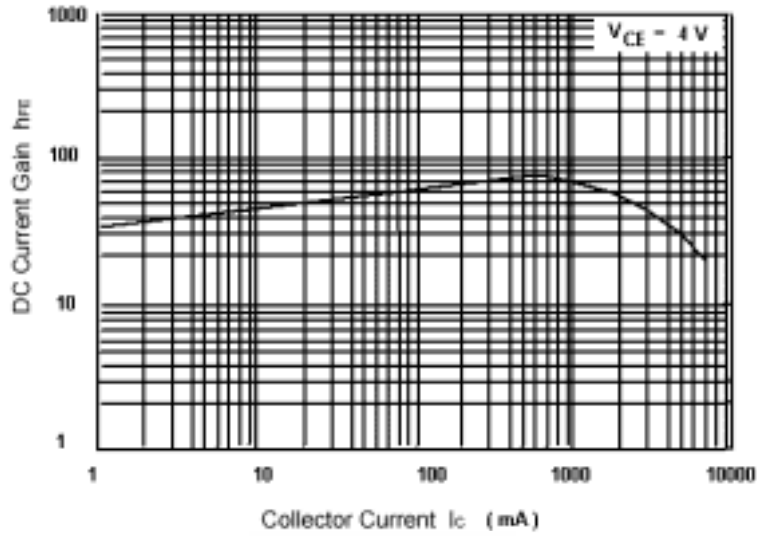

Fig.3 DC current Gain

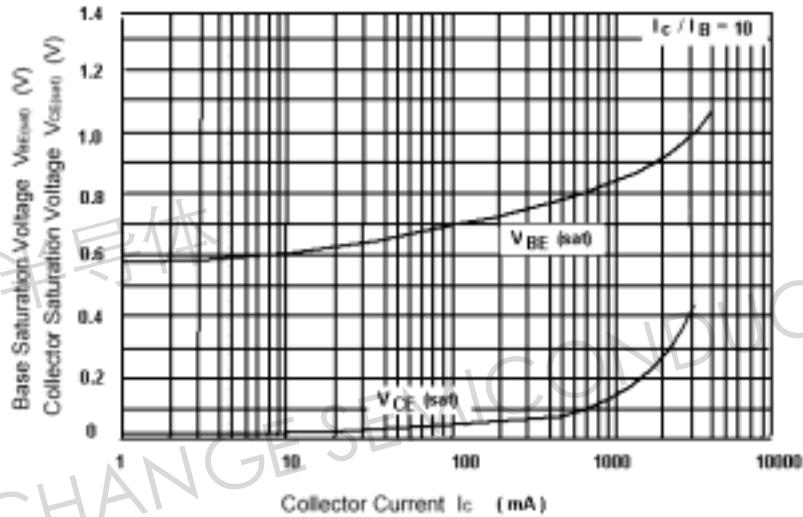

Fig.4 Base-Emitter Saturation Voltage
Collector-Emitter Saturation Voltage

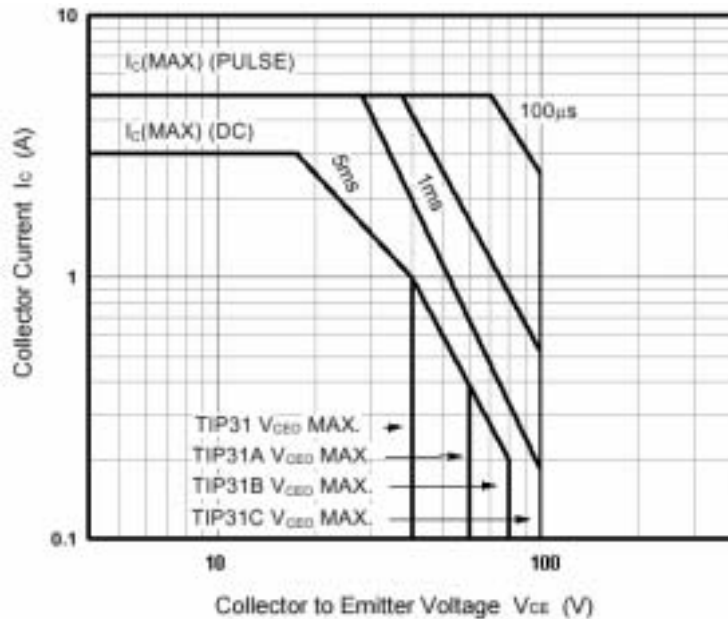

Fig.5 Safe Operating Area